

JJ400 SERIES

JUNIOR JET FARMMASTER PUMP JET ASSISTED PRESSURE PUMP



FEATURES

- Injectors to suit a large range of applications.
- Offset combinations available.
- No moving parts down bore.
- Shallow well lifts 7.6m.
- Deep well lifts to 27m.
- Manual or automatic system.
- Max. head - 52m.
- Max. flow - 98lpm.



APPLICATIONS

- Domestic, industrial or rural pressure pump for use as a manual or automatic pressure system.
- Stock watering, irrigation and water transfer.
- Option of a large range of water sources including tanks, bores, dams, creeks and rivers, thanks to various injector combinations.

PUMP INFORMATION

Horizontal, single-stage, surface mounted centrifugal pump. Jet and venturi assisted performance with closed impeller for pumping debris free water. Cast iron injector housing and pump casing with 1 1/2" BSP (female) inlet and 3/4" BSP (female) outlet.

OPERATING CONDITIONS

Suitable for pumping clean non-aggressive liquids without solids or fibres in suspension.

Fluid:	Water
Maximum water temperature:	55°C
Minimum water temperature:	1°C
Maximum ambient temperature:	40°C

JJ400 Series - Technical Data

ELECTRICAL DATA

Type	Type of current	Voltage ± 10%	Frequency Hz	Motor rating kW		Normal RPM	Current ampere	Locked rotor current	Motor protection	Insulation class	IP rating
				P1	P2						
JJ400	1-phase	230	50	1	0.75	2900	4.5 A	19 A	Auto	B	55

PERFORMANCE

Type	Injector model	Pressure switch setting (kPa)	Suction depth (m)	Total head in metres					Maximum pump pressure (kPa)
				15	21	27	34	40	
				Capacity (litres per minute)					
JJ400	S500	140-280*	0	98	70	40			380
			3	78	56	32			350
			6	56	40	23			320
			7.6	39	28	16			305
	S501	210-350#	0	71	66	42	21		440
			3	57	53	34	17		410
			6	40	38	24	12		380
			7.6	28	26	17	8		
	S502	280-420*	0		47	42	24	14	505
			3		38	34	19	11	475
			6		27	24	14	8	445
			7.6		19	17	10	6	430

#Factory pressure switch setting. *Pressure switch adjustment needed.

PERFORMANCE CURVE

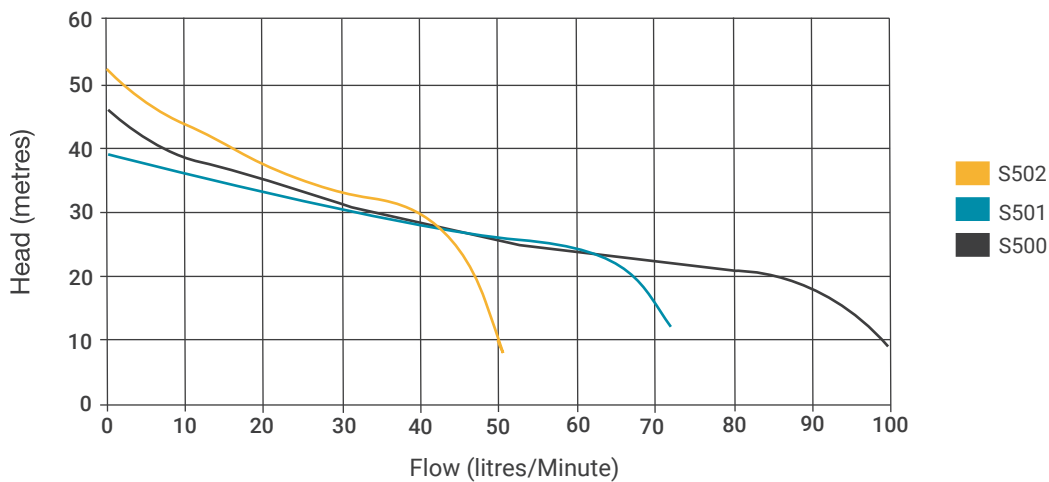

JJ400 Series- Technical Data

DIMENSIONS

Type	Maximum L x W x H	Weight approx	Inlet	Pump outlet	Pressure kit outlet	Carton L x W x H	Packed weight
JJ400	510 x 180 x 200 mm	18 kg	1 1/2" BSP (female)	3/4" BSP (female)	1" BSP (female)	590 x 300 x 330 mm	19 kg

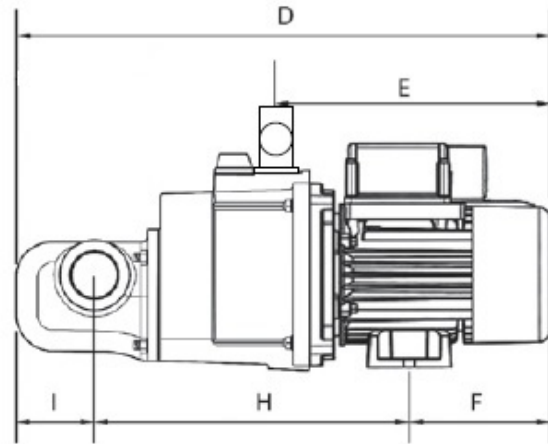
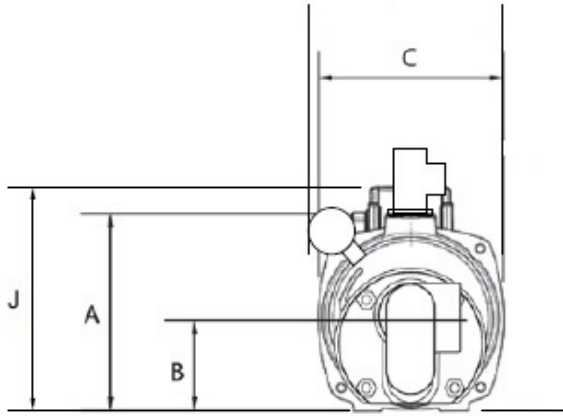

Pump not supplied with shallow well assembly.

Type	A	B	C	D	E	F	H	I	J
JJ400	190	90	180	525	255	140	305	80	220

PUMP CONSTRUCTION MATERIALS

Component	Material
Pump casing	Cast iron
Impeller	Polycarb 20% glass filled
Baffle	ABS glass filled
Diffuser	Noryl
Priming / drain plug	Acetal
Shaft sleeve	Nylon
Mechanical seal	Carbon / ceramic
Motor shaft	Mild steel