



# PENTAIR STARLINE

MOTORPUMPS

50Hz PERFORMANCE

## SELECTION CHART 1450/2900 R.P.M.

CENTRIFUGAL PUMP PERFORMANCE DATA

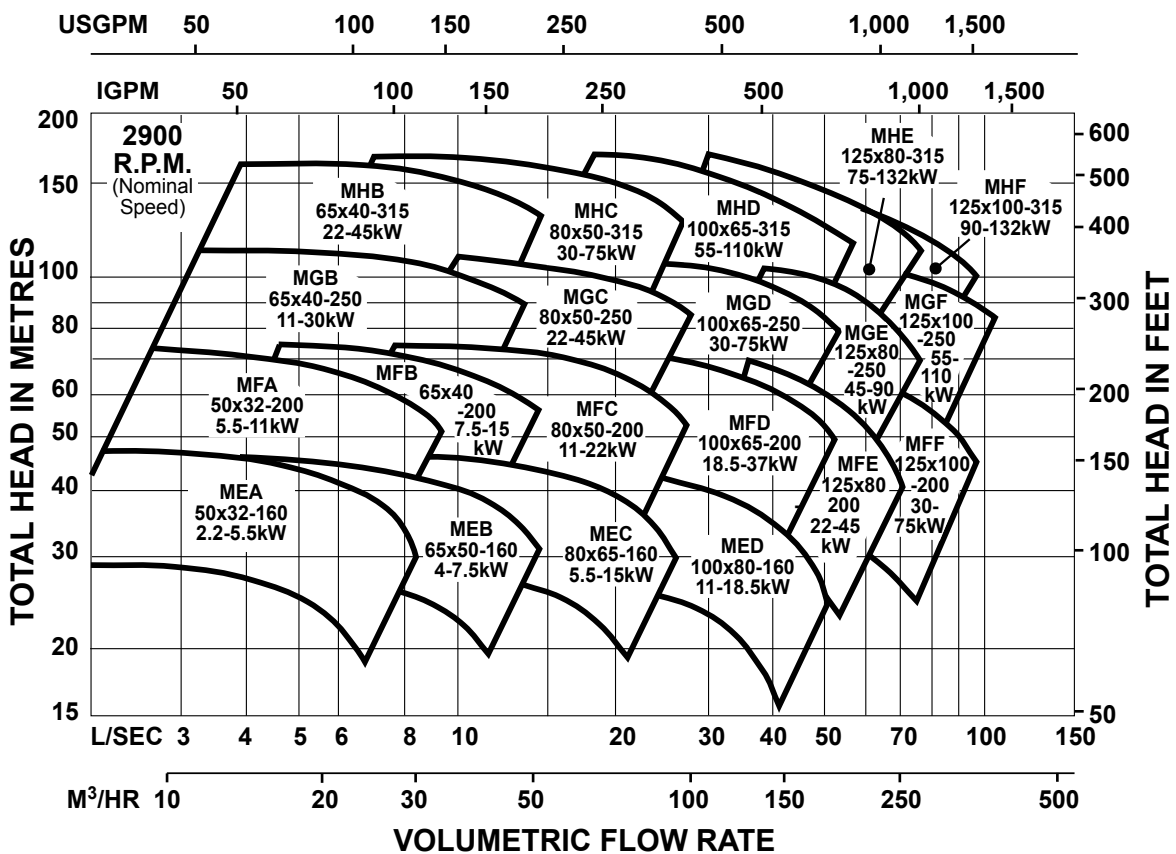
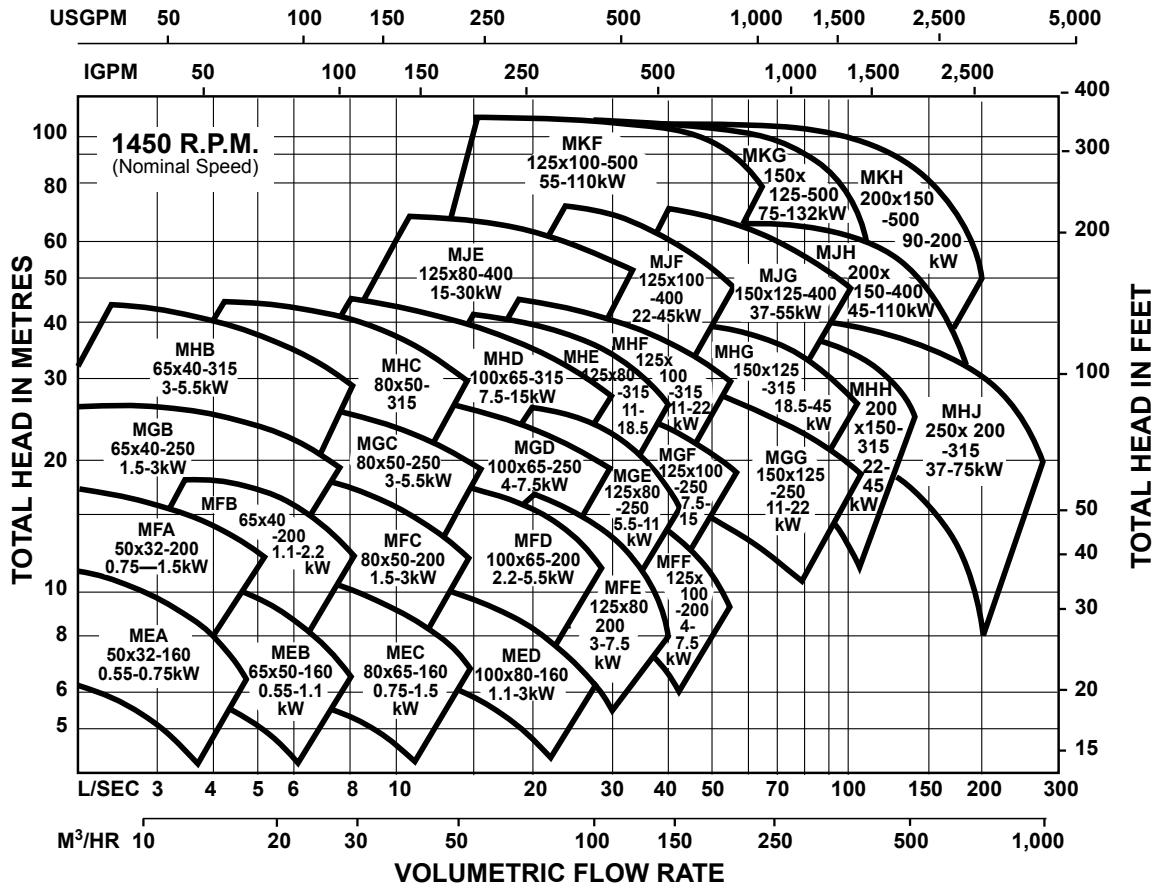



# PENTAIR STARLINE

MOTORPUMPS  
50Hz PERFORMANCE

SELECTION CHART

## 970

CENTRIFUGAL PUMP PERFORMANCE DATA

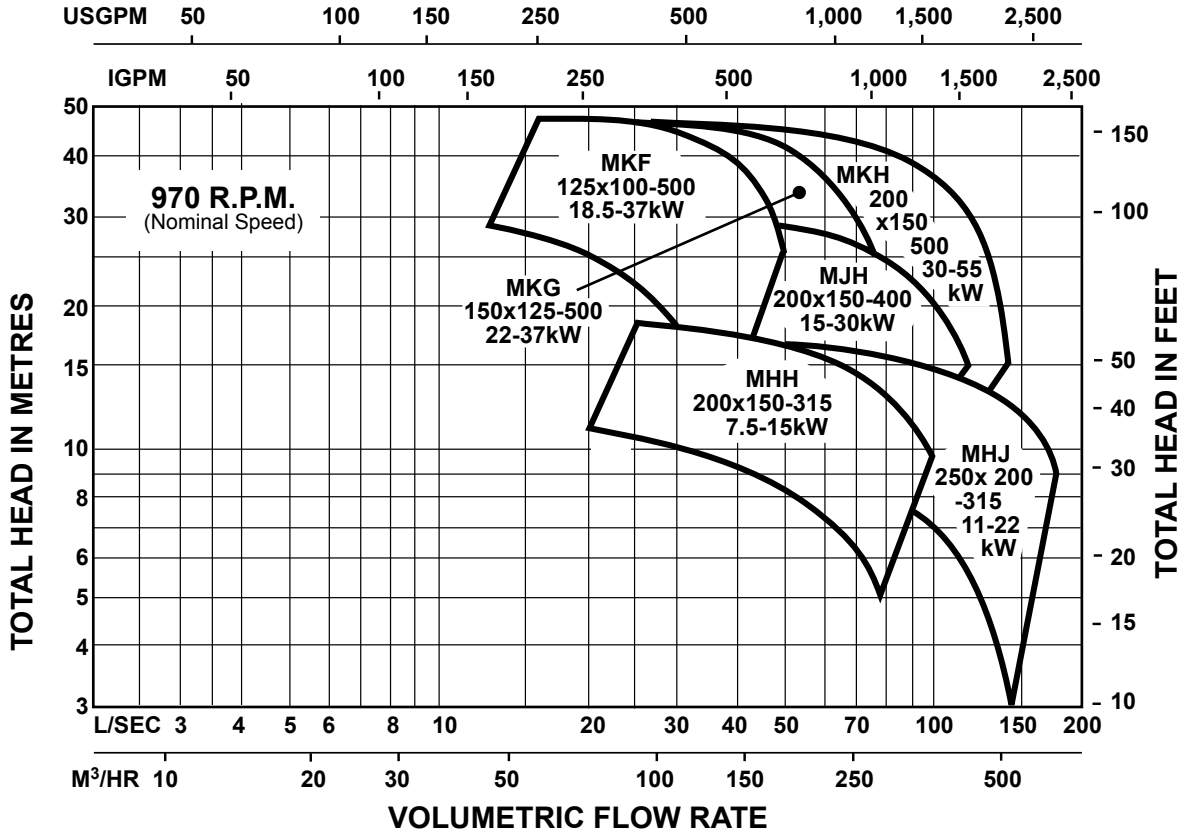



# PENTAIR STARLINE

MOTORPUMPS

50Hz PERFORMANCE

## MODEL 50x32-160

CENTRIFUGAL PUMP PERFORMANCE DATA

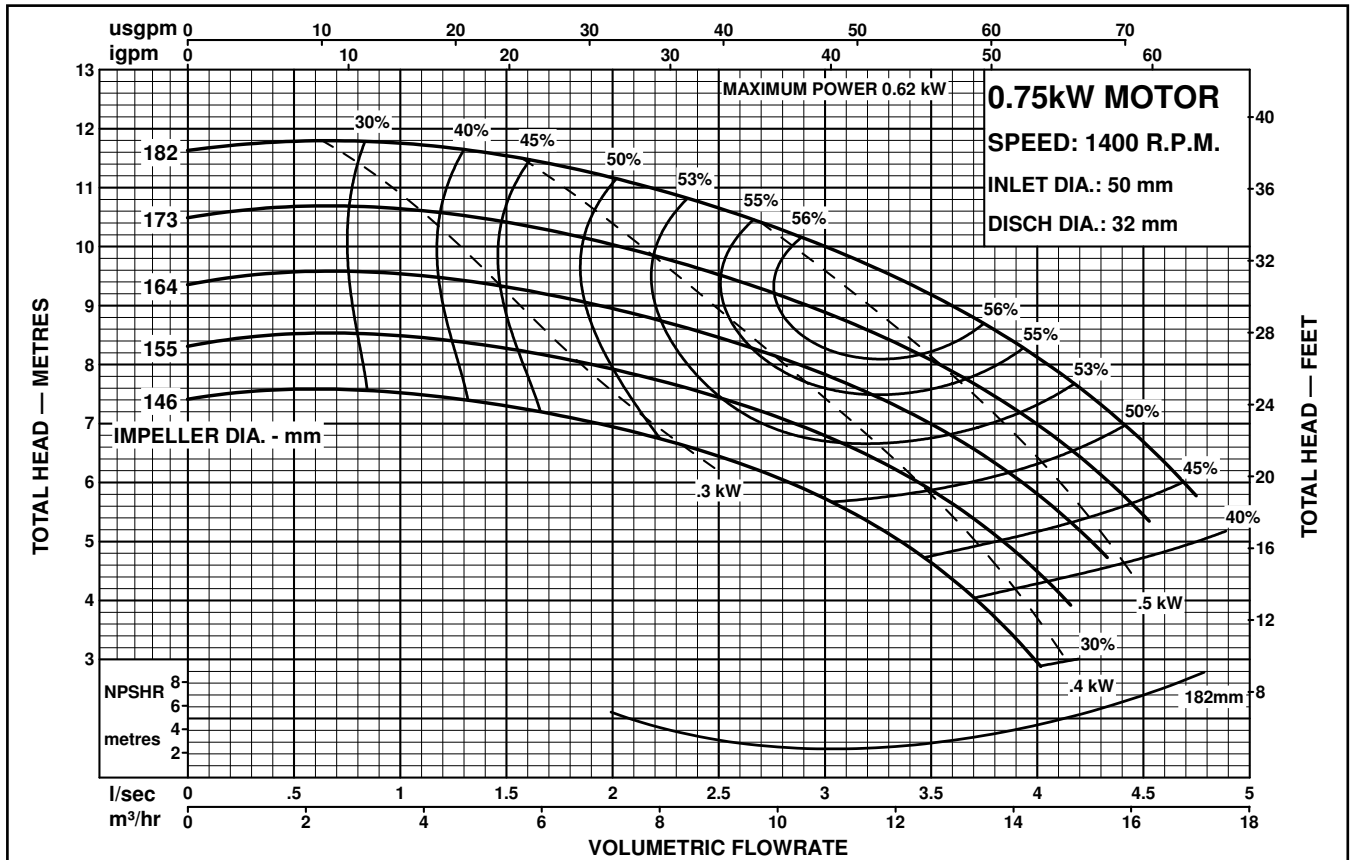

Performance to AS2417 Grade 2 for clean, cold water only.

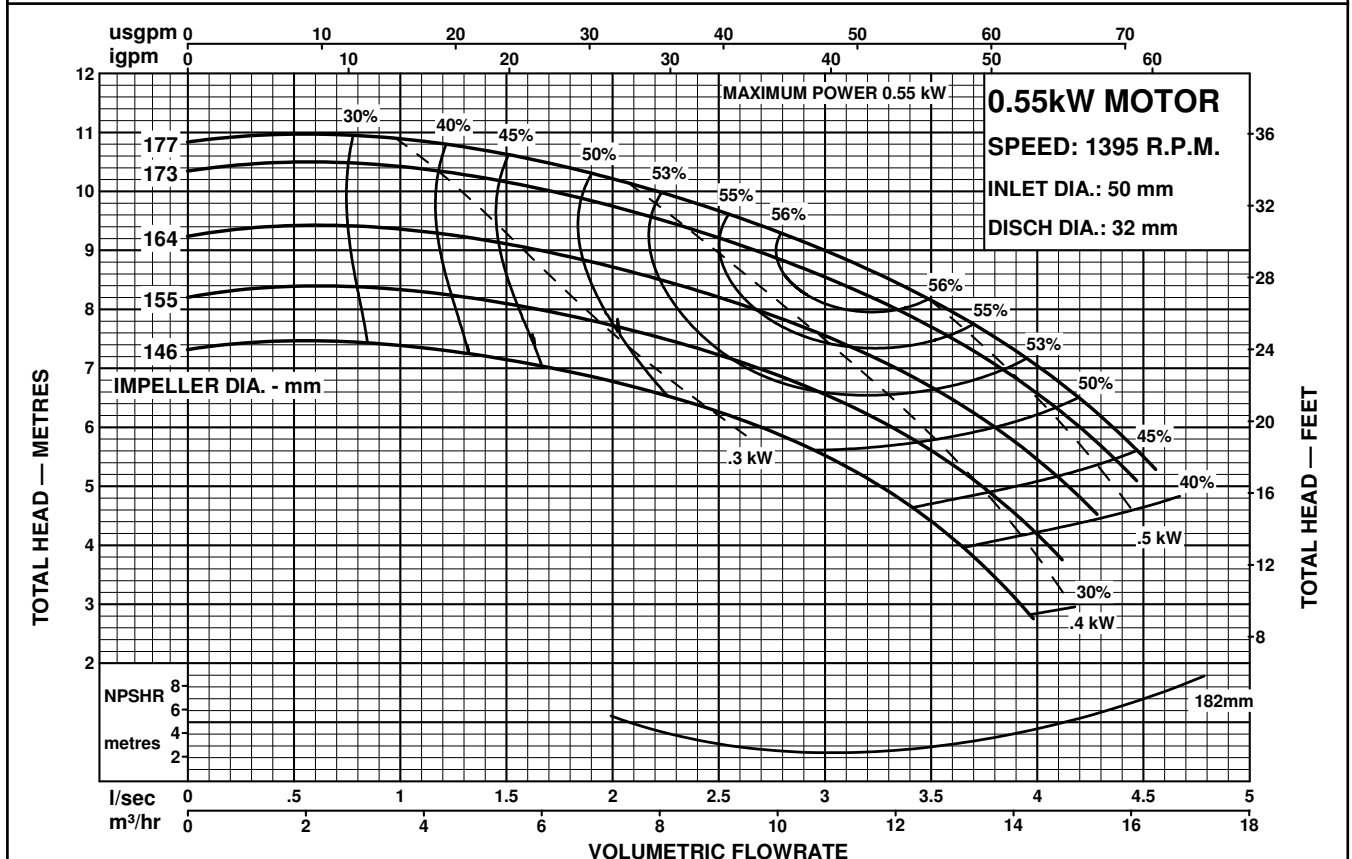

Performance to AS2417 Grade 2 for clean, cold water only.





# PENTAIR STARLINE

MOTORPUMPS  
50Hz PERFORMANCE

MODEL  
**50x32-160**

CENTRIFUGAL PUMP PERFORMANCE DATA

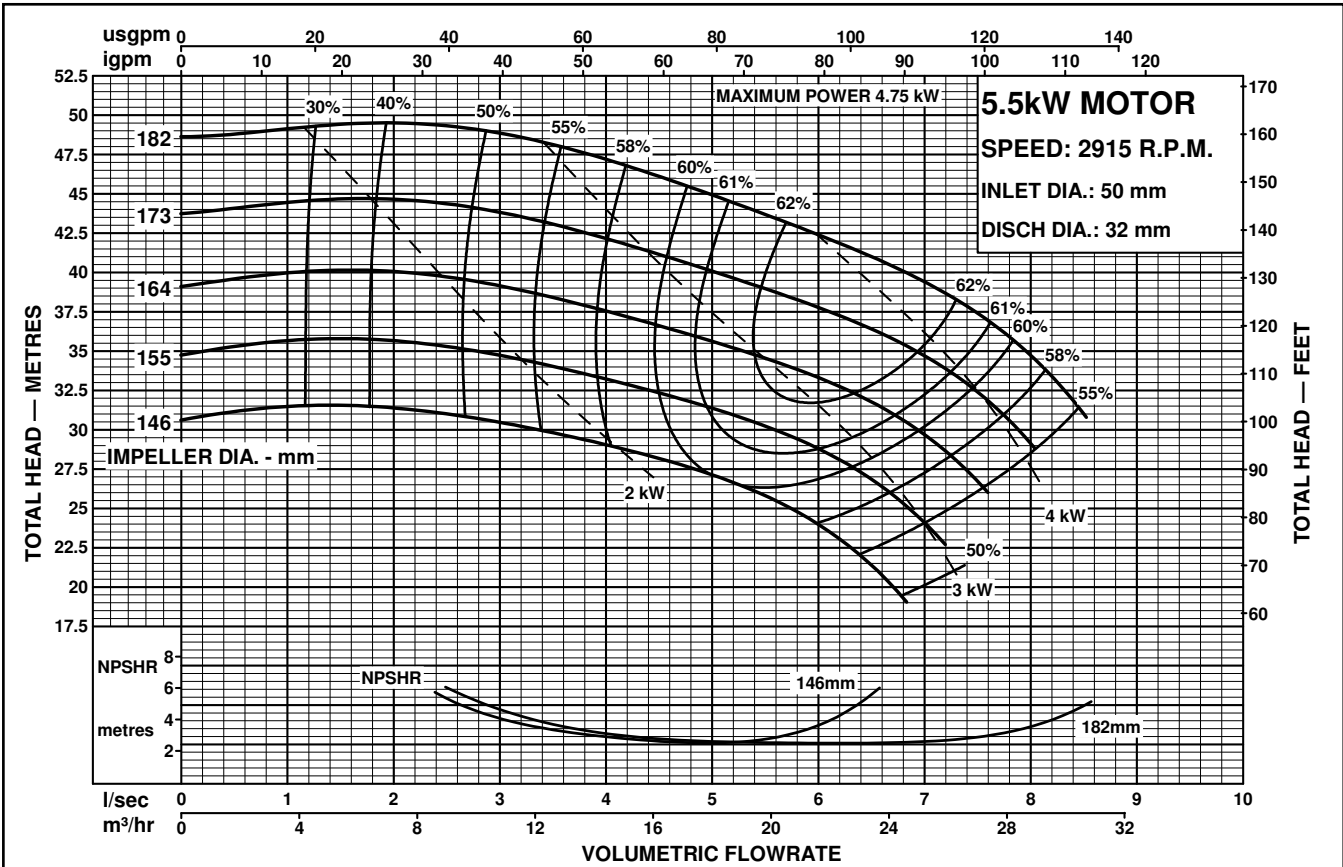

Performance to AS2417 Grade 2 for clean, cold water only.

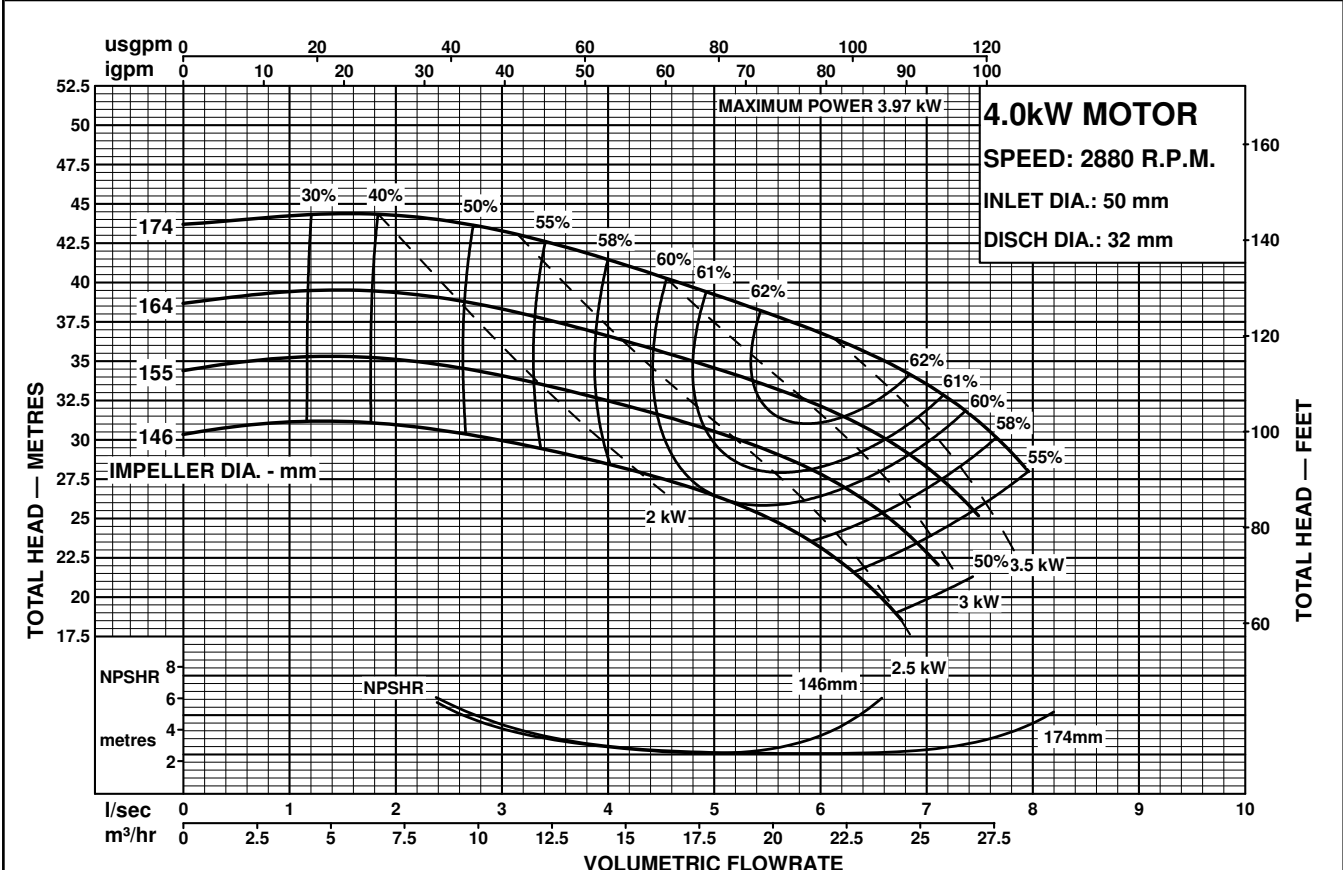

Performance to AS2417 Grade 2 for clean, cold water only.





# PENTAIR STARLINE

MOTORPUMPS

50Hz PERFORMANCE

## MODEL 50x32-160

CENTRIFUGAL PUMP PERFORMANCE DATA

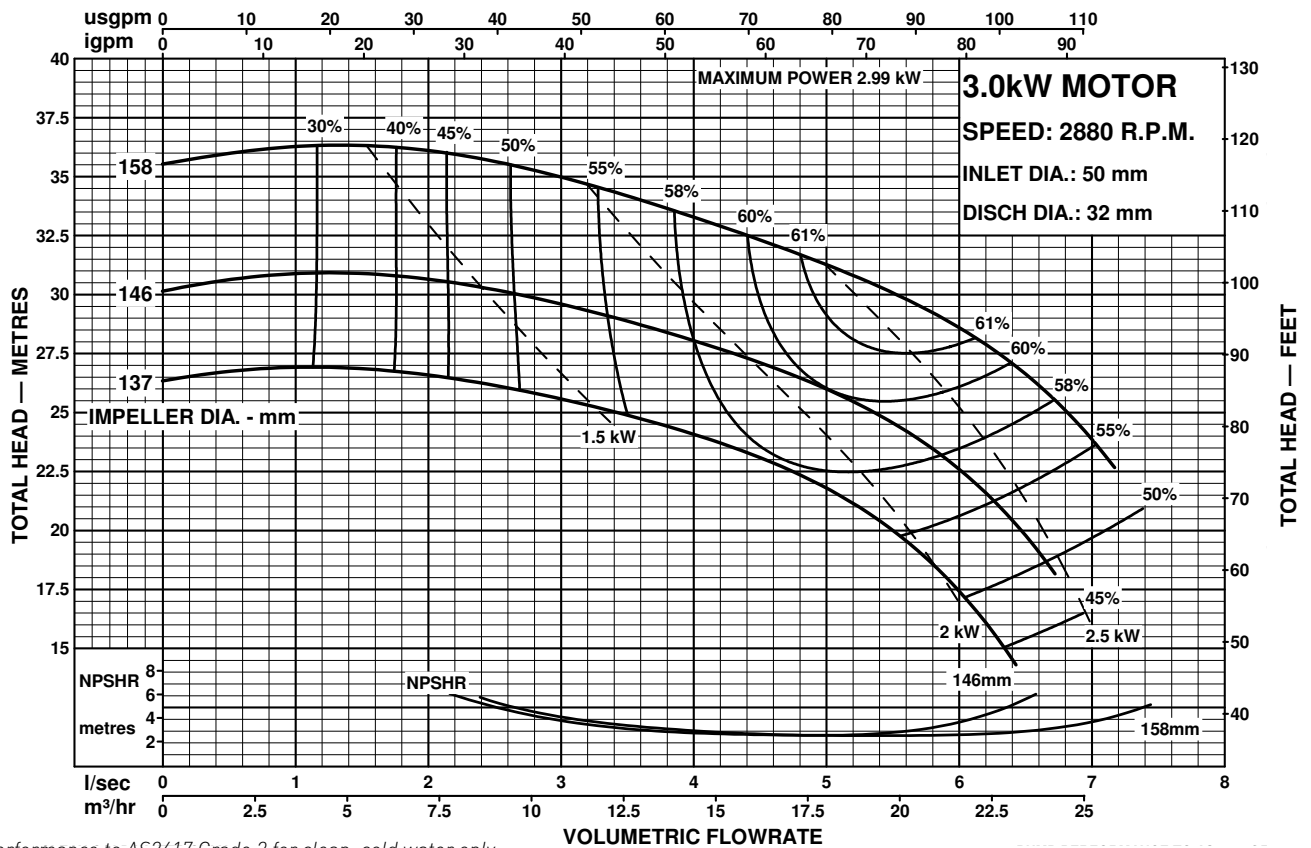

Performance to AS2417 Grade 2 for clean, cold water only.

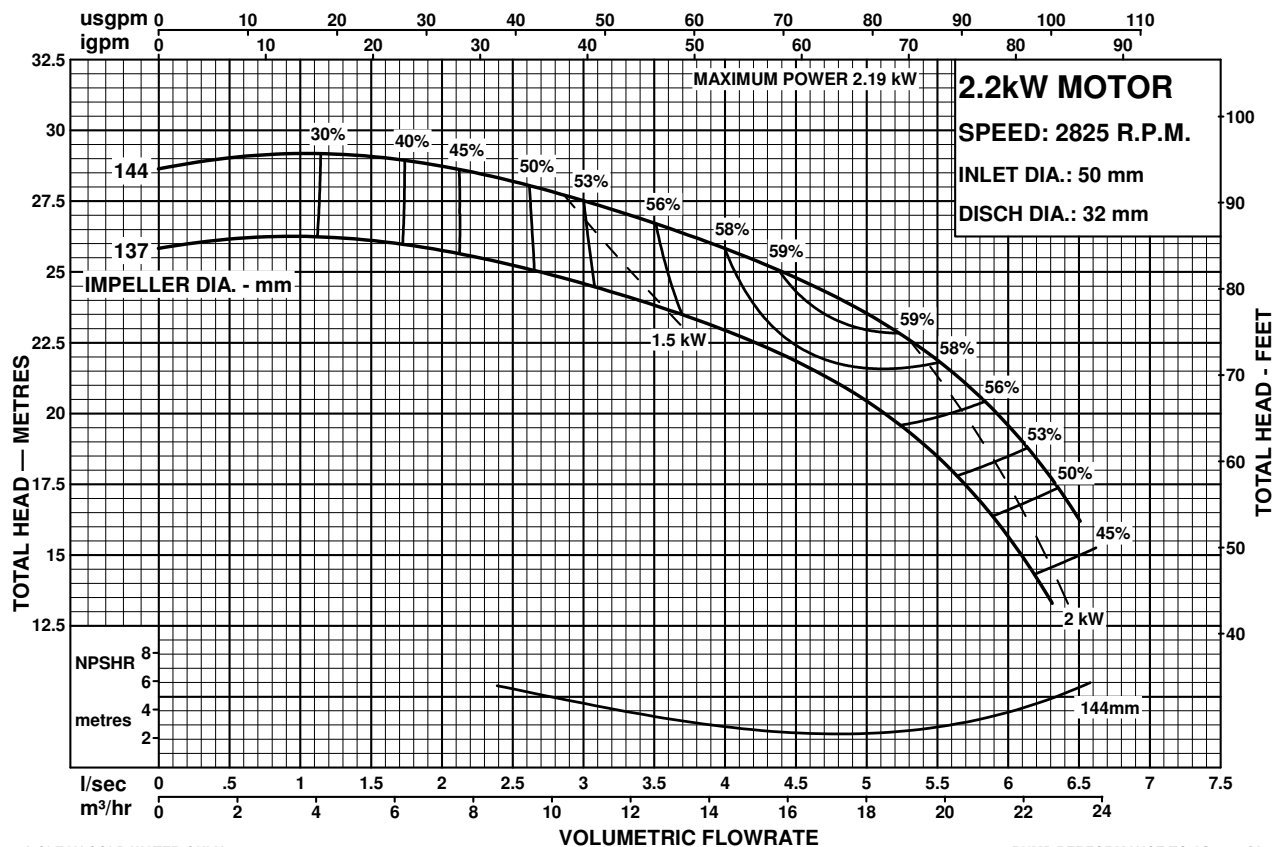

Performance to AS2417 Grade 2 for clean, cold water only.





# PENTAIR STARLINE

MOTORPUMPS  
50Hz PERFORMANCE

MODEL  
**50x32-200**

CENTRIFUGAL PUMP PERFORMANCE DATA

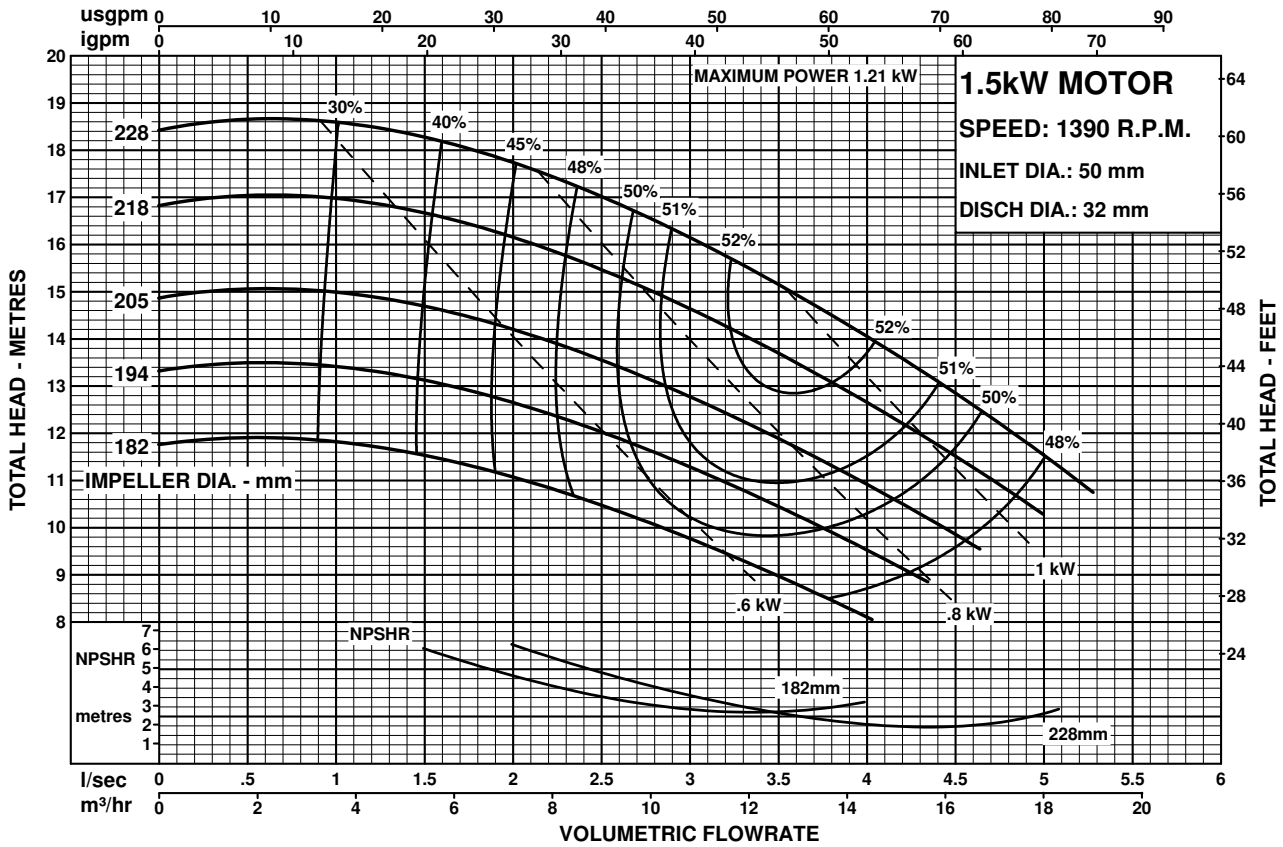

Performance to AS2417 Grade 2 for clean, cold water only.

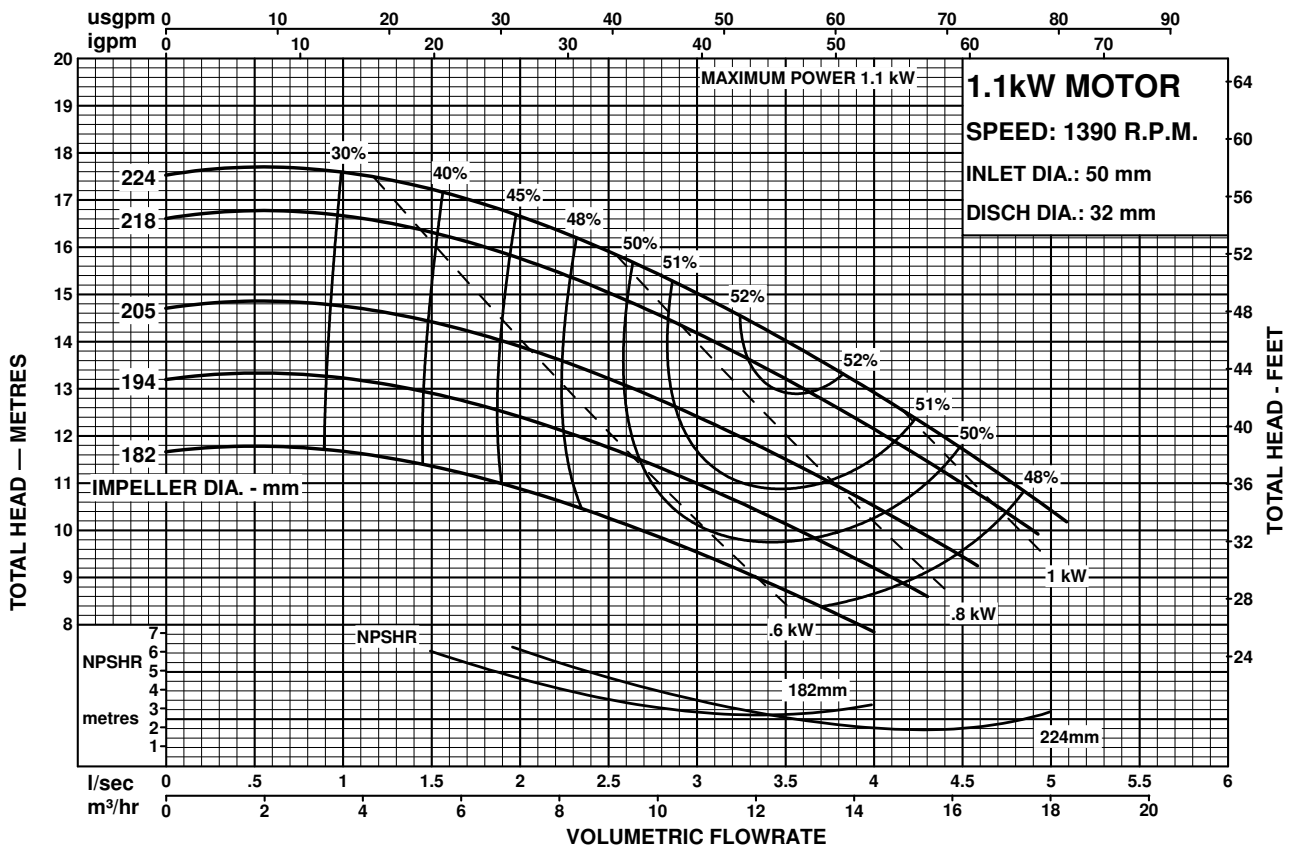

Performance to AS2417 Grade 2 for clean, cold water only.





# PENTAIR STARLINE

MOTORPUMPS  
50Hz PERFORMANCE

MODEL  
**50x32-200**

CENTRIFUGAL PUMP PERFORMANCE DATA

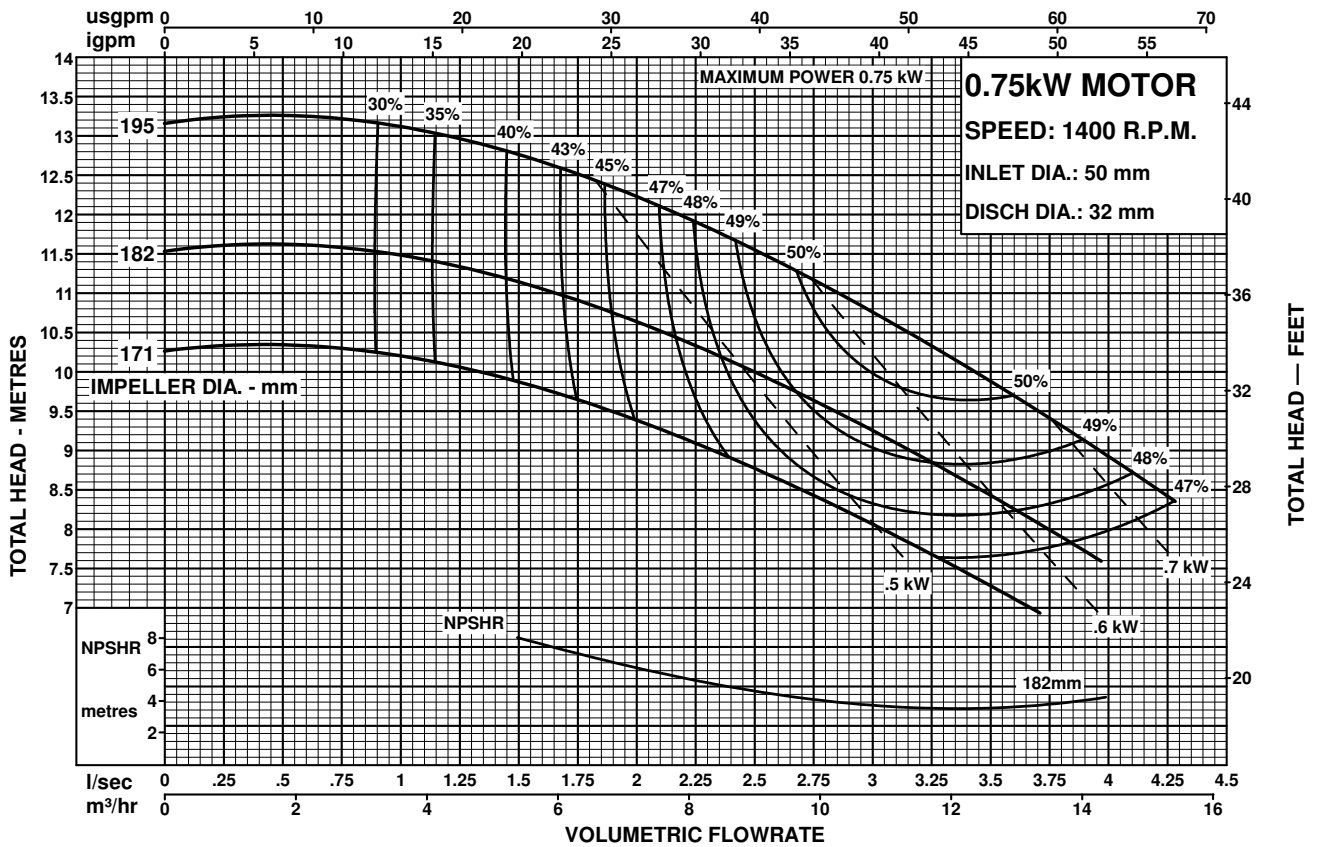

Performance to AS2417 Grade 2 for clean, cold water only.





# PENTAIR STARLINE

MOTORPUMPS  
50Hz PERFORMANCE

MODEL  
**50x32-200**

CENTRIFUGAL PUMP PERFORMANCE DATA

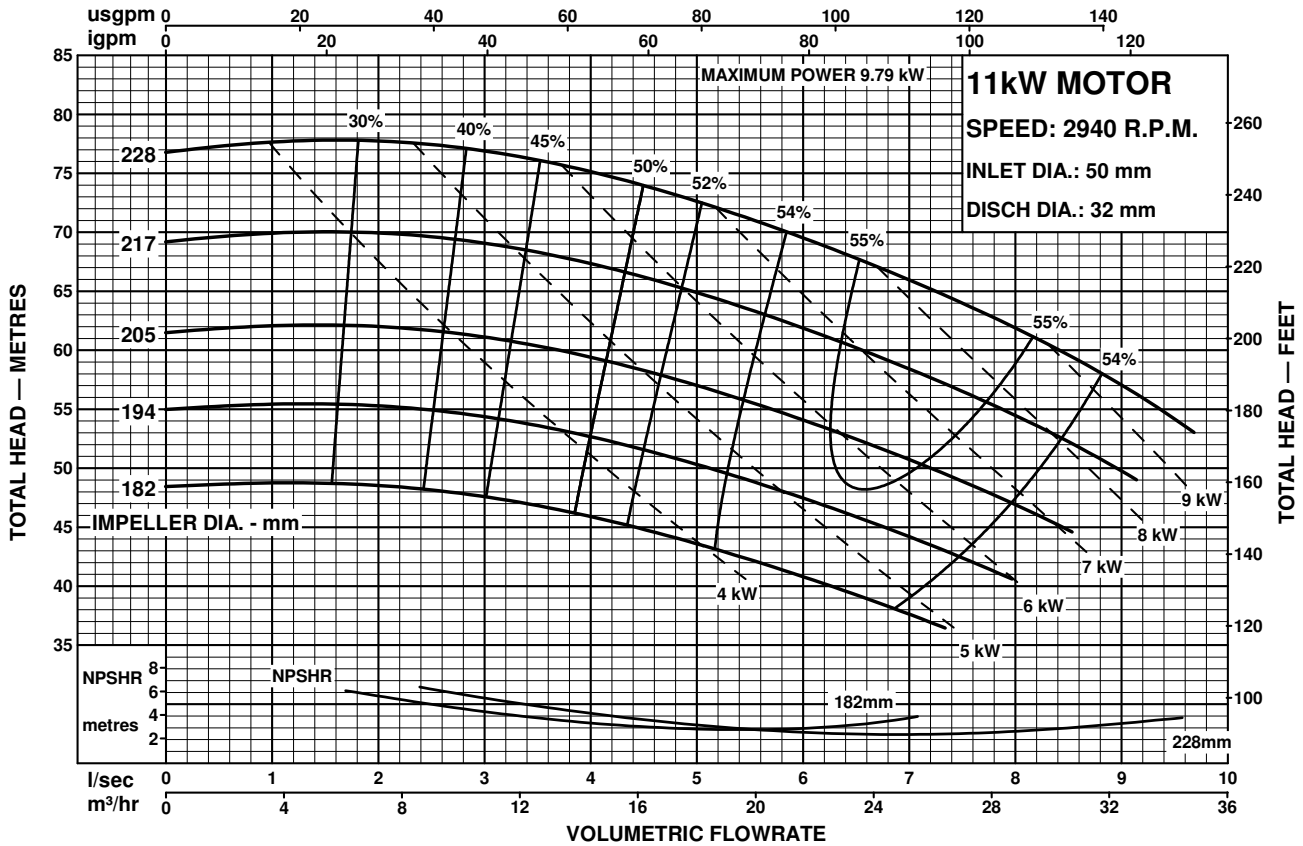

Performance to AS2417 Grade 2 for clean, cold water only.

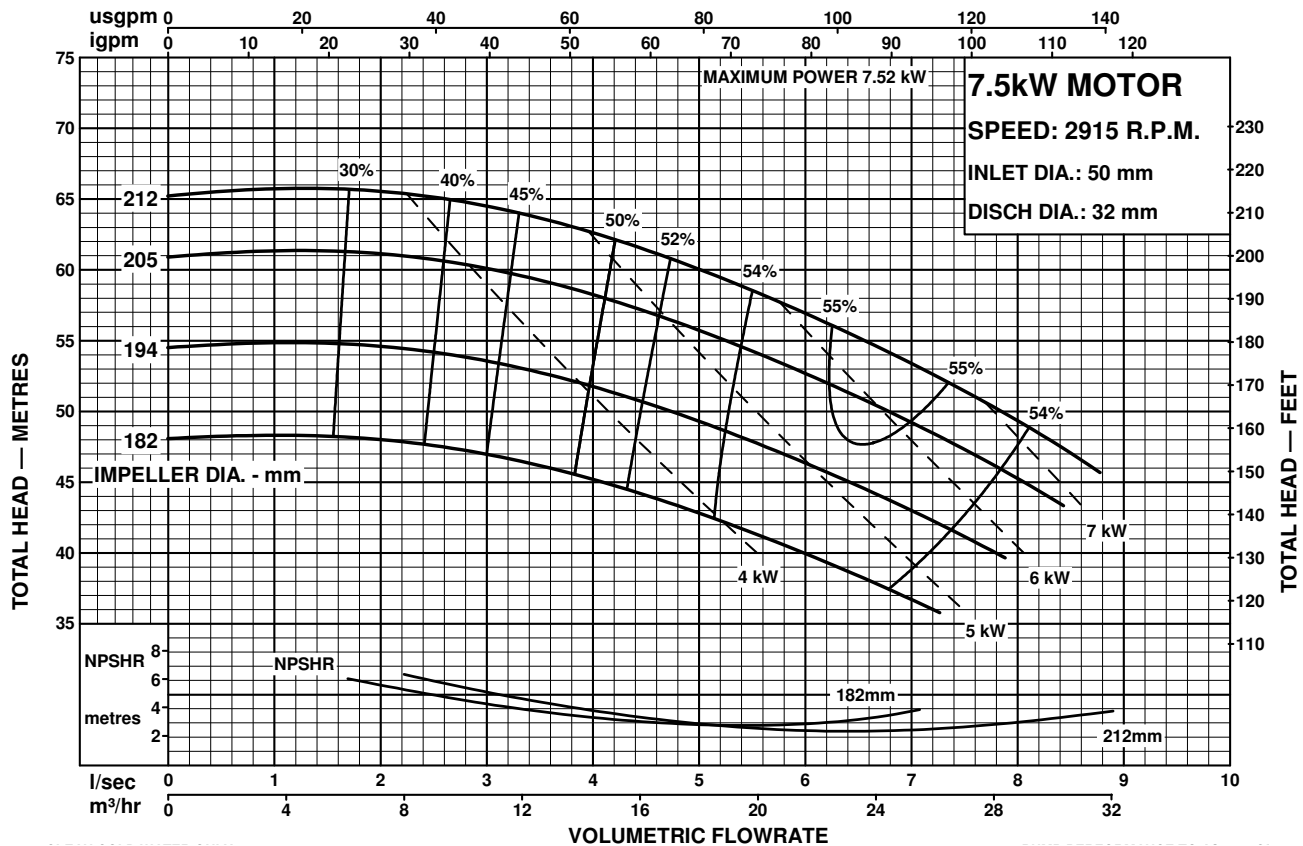

Performance to AS2417 Grade 2 for clean, cold water only.







# PENTAIR STARLINE

MOTORPUMPS  
50Hz PERFORMANCE

MODEL  
**50x32-200**

CENTRIFUGAL PUMP PERFORMANCE DATA

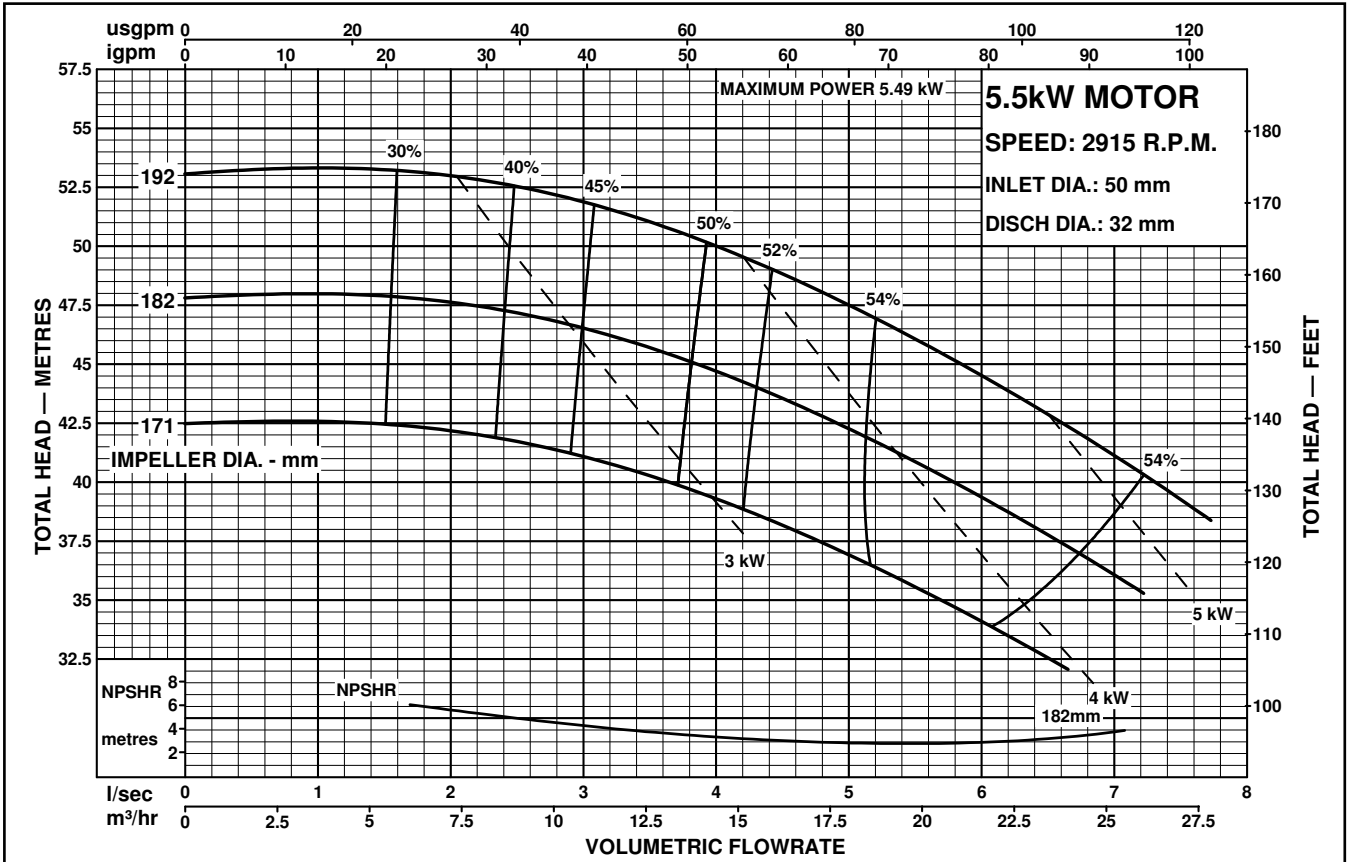

Performance to AS2417 Grade 2 for clean, cold water only.





# PENTAIR STARLINE

MOTORPUMPS  
50Hz PERFORMANCE

MODEL  
**65x50-160**

CENTRIFUGAL PUMP PERFORMANCE DATA

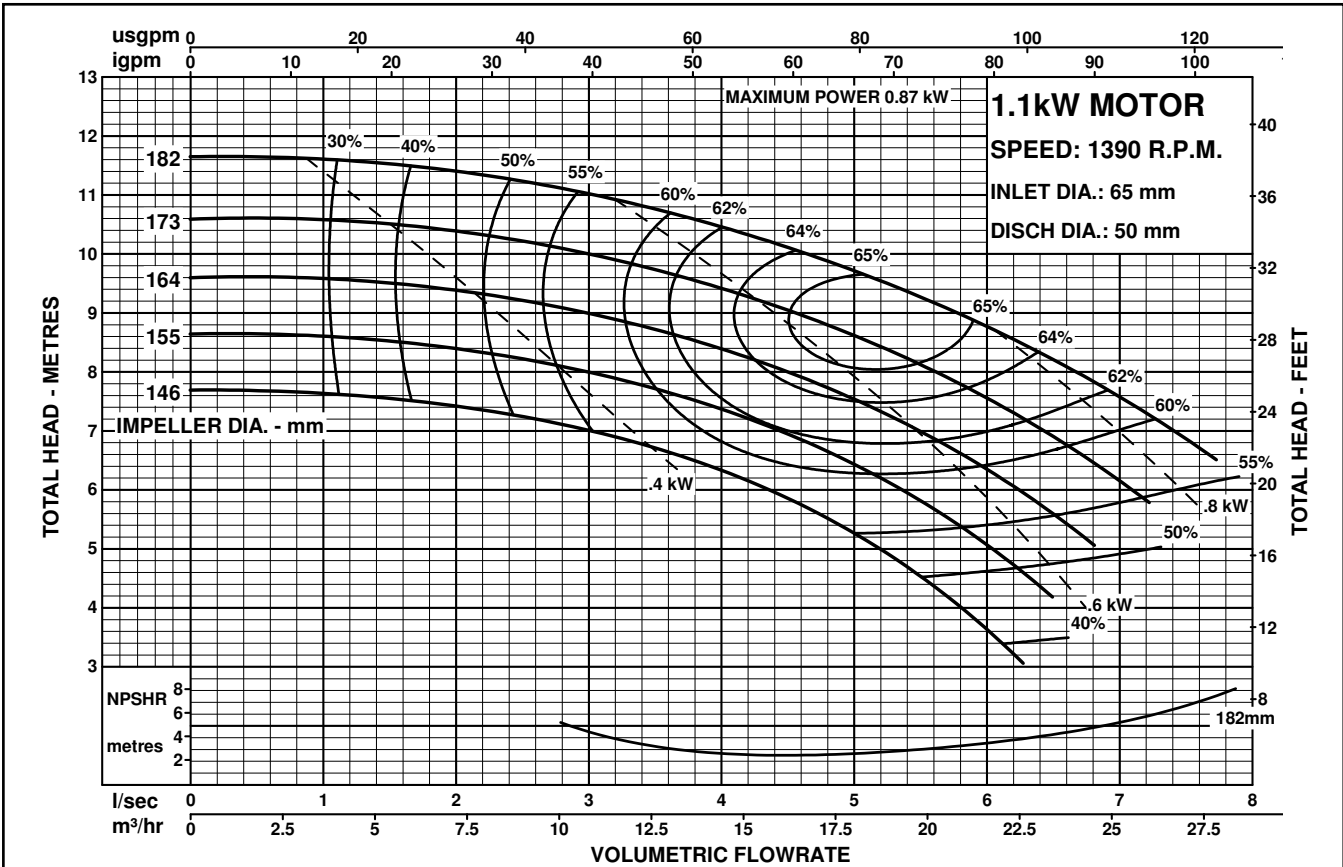

Performance to AS2417 Grade 2 for clean, cold water only.

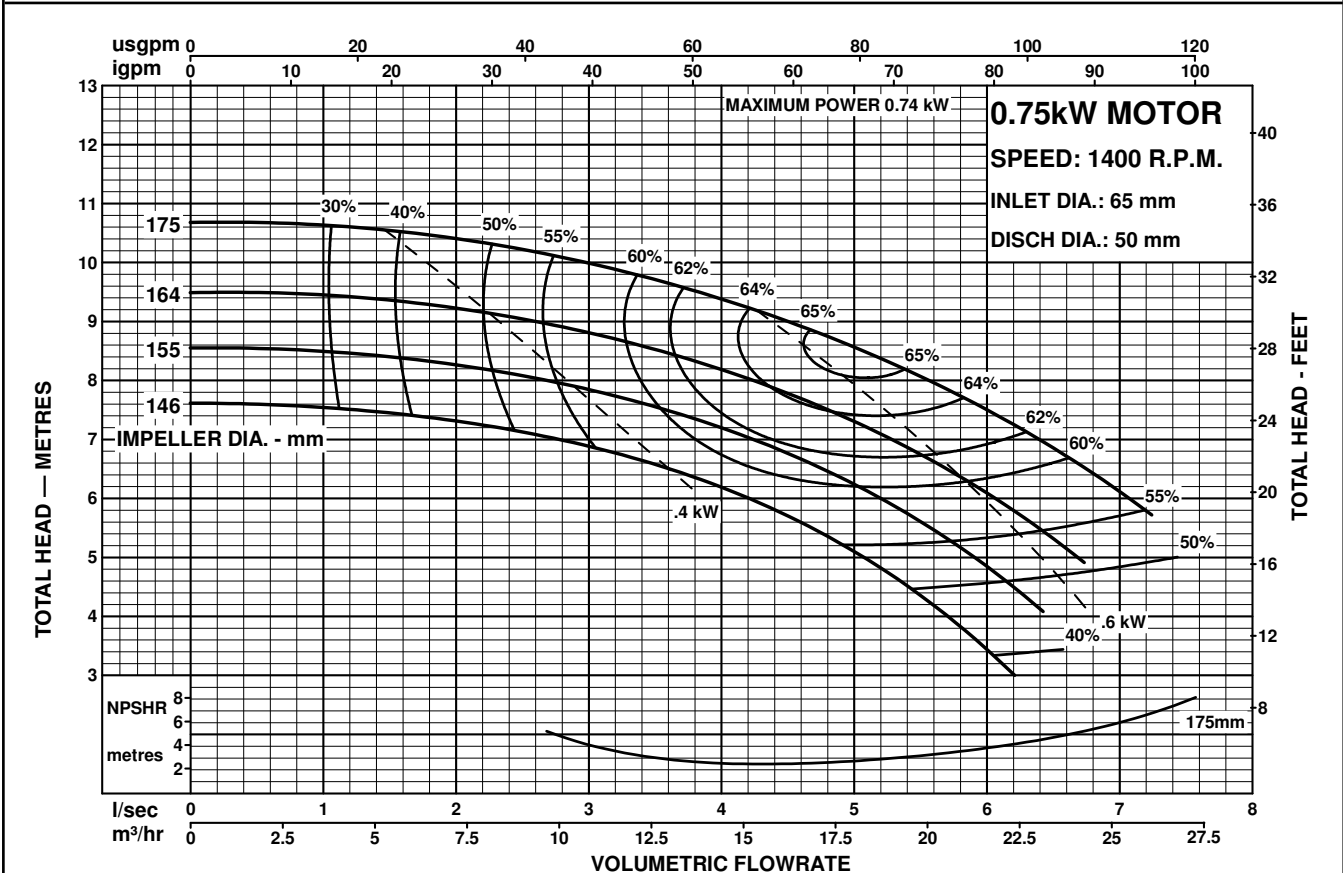

Performance to AS2417 Grade 2 for clean, cold water only.





# PENTAIR STARLINE

MOTORPUMPS  
50Hz PERFORMANCE

MODEL  
**65x50-160**

CENTRIFUGAL PUMP PERFORMANCE DATA

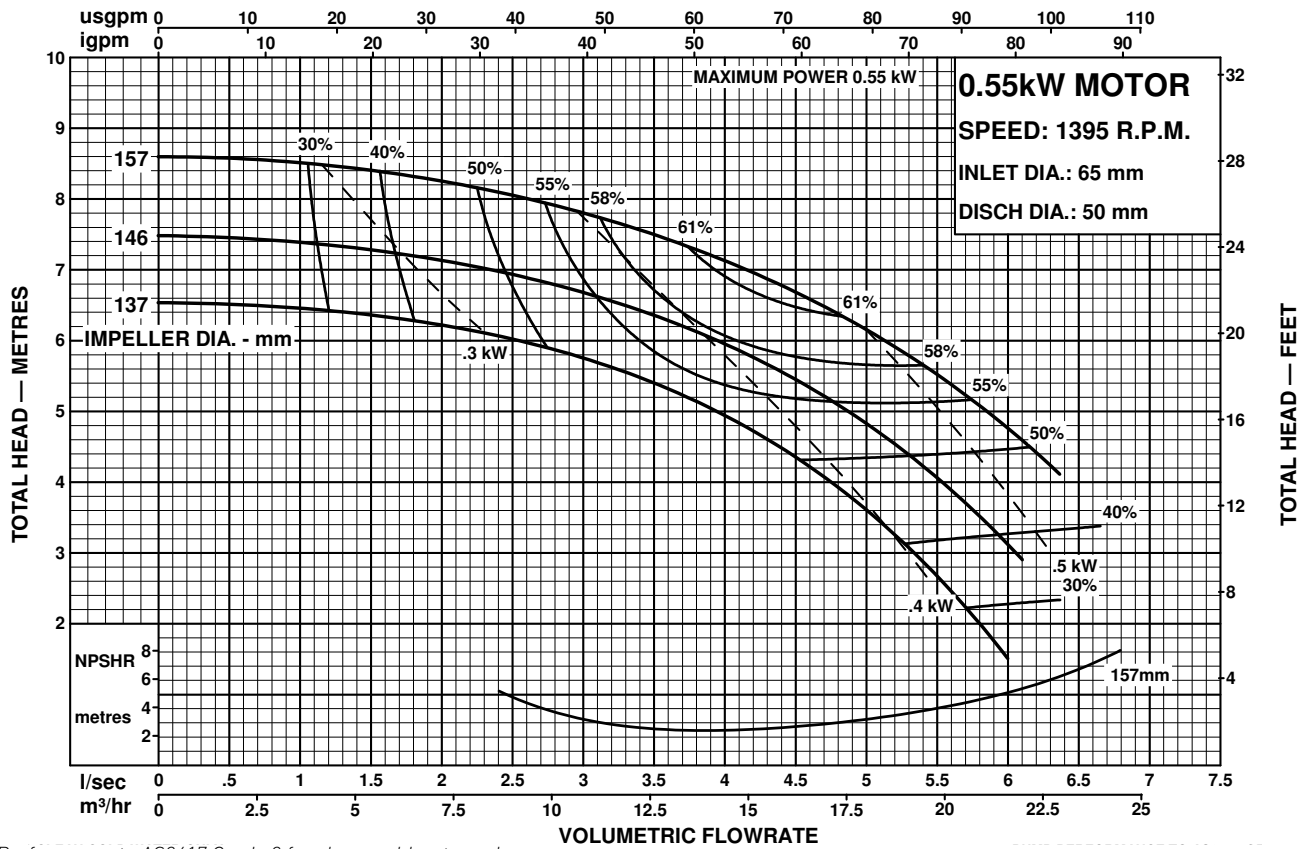



# PENTAIR STARLINE

MOTORPUMPS  
50Hz PERFORMANCE

MODEL  
**65x50-160**

CENTRIFUGAL PUMP PERFORMANCE DATA

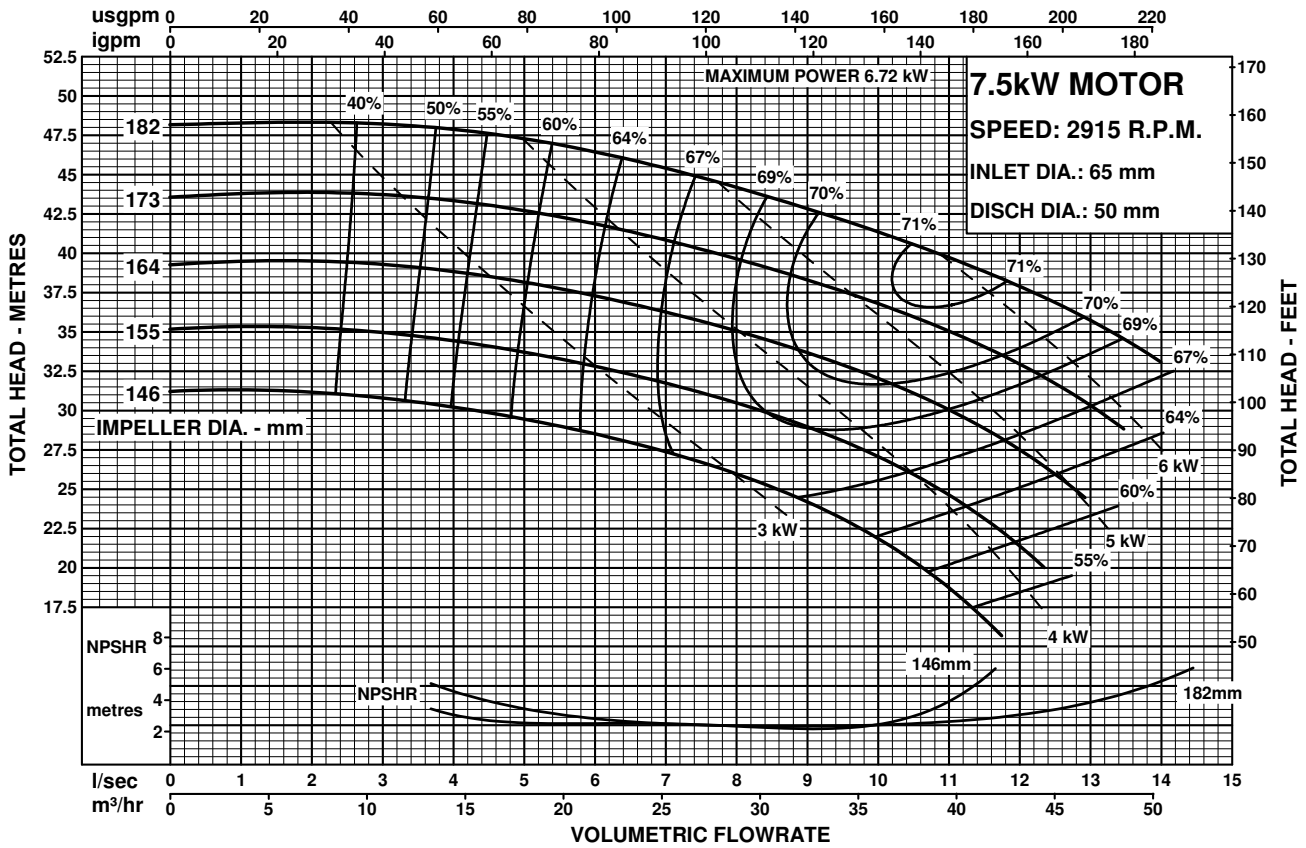

Performance to AS2417 Grade 2 for clean, cold water only.

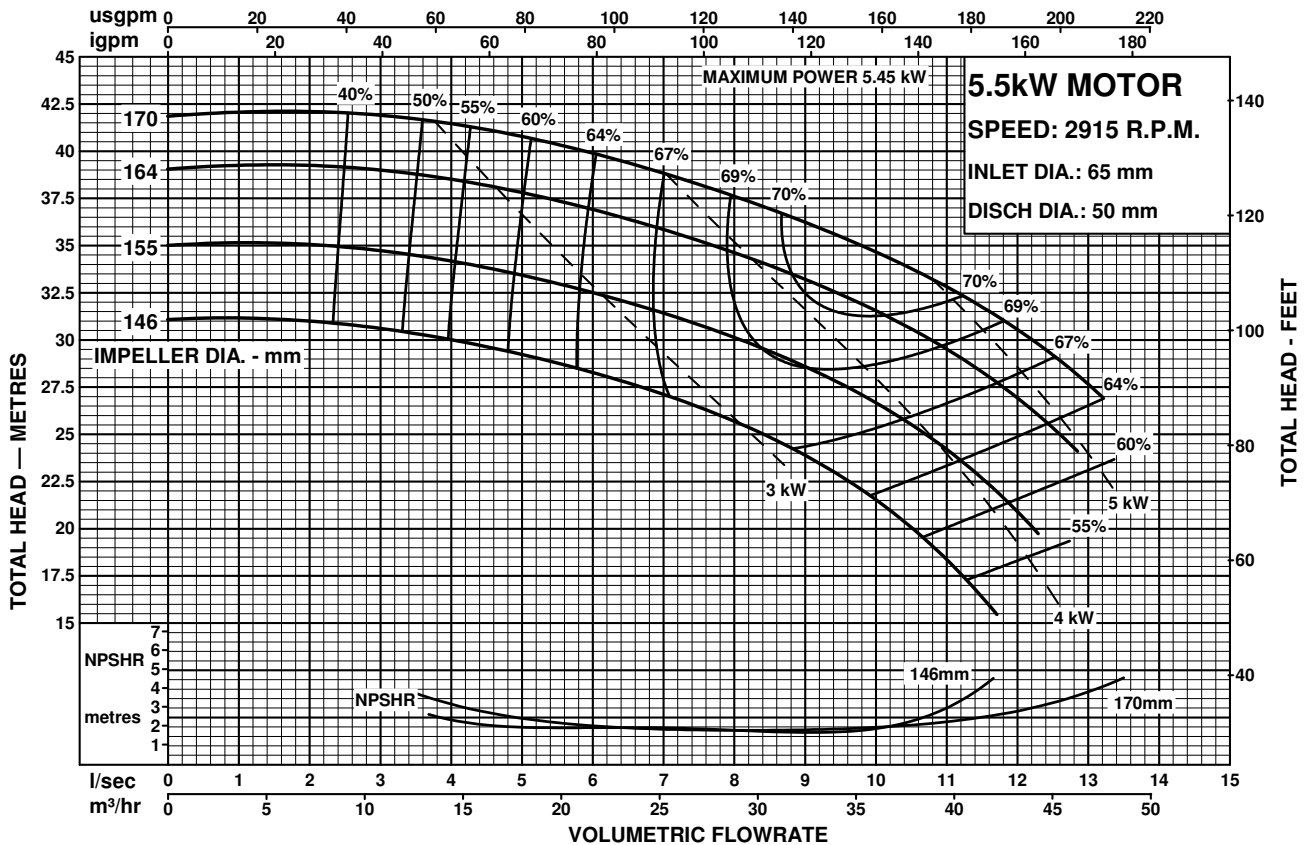

Performance to AS2417 Grade 2 for clean, cold water only.



# PENTAIR STARLINE

MOTORPUMPS  
50Hz PERFORMANCE

MODEL  
**65x50-160**

CENTRIFUGAL PUMP PERFORMANCE DATA

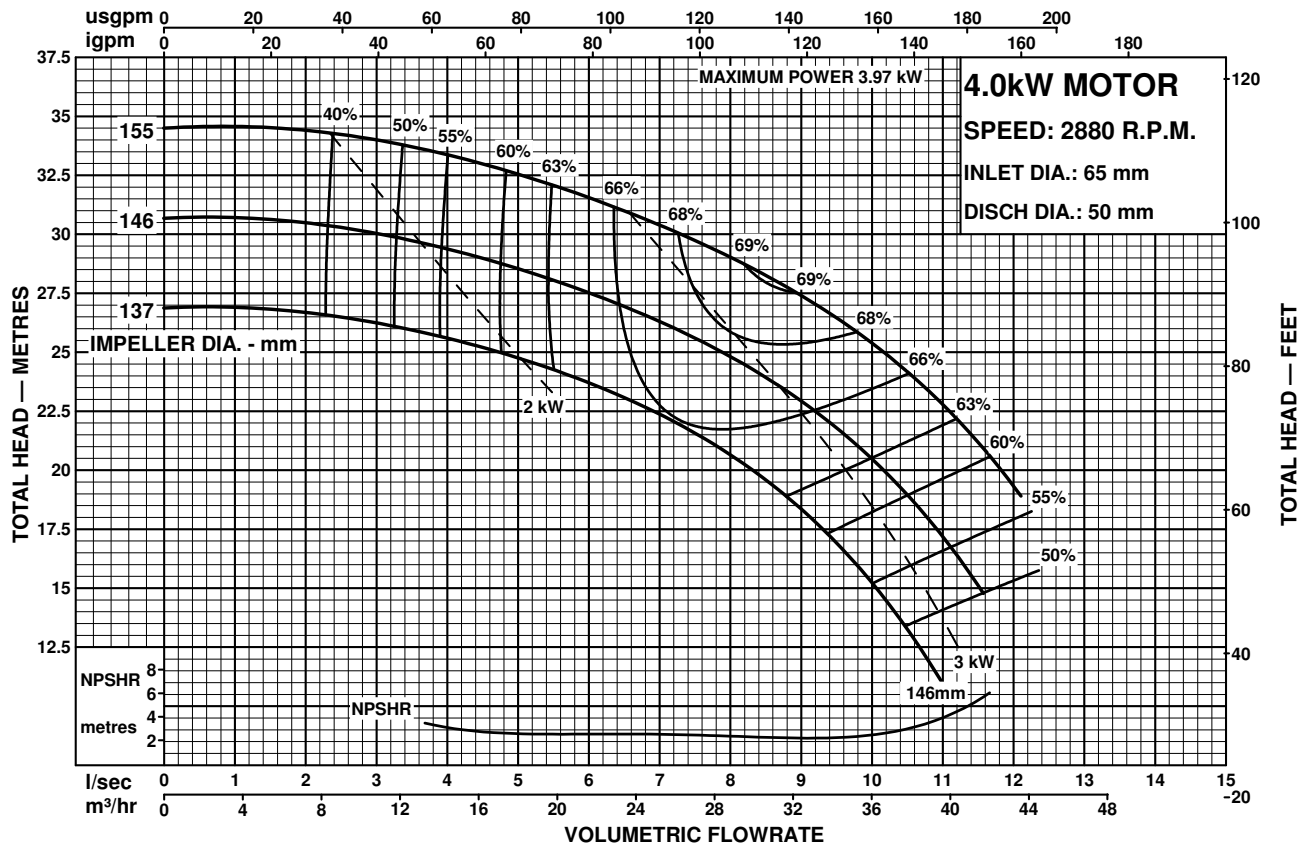

Performance to AS2417 Grade 2 for clean, cold water only.





# PENTAIR STARLINE

MOTORPUMPS  
50Hz PERFORMANCE

MODEL  
**65x40-200**

CENTRIFUGAL PUMP PERFORMANCE DATA

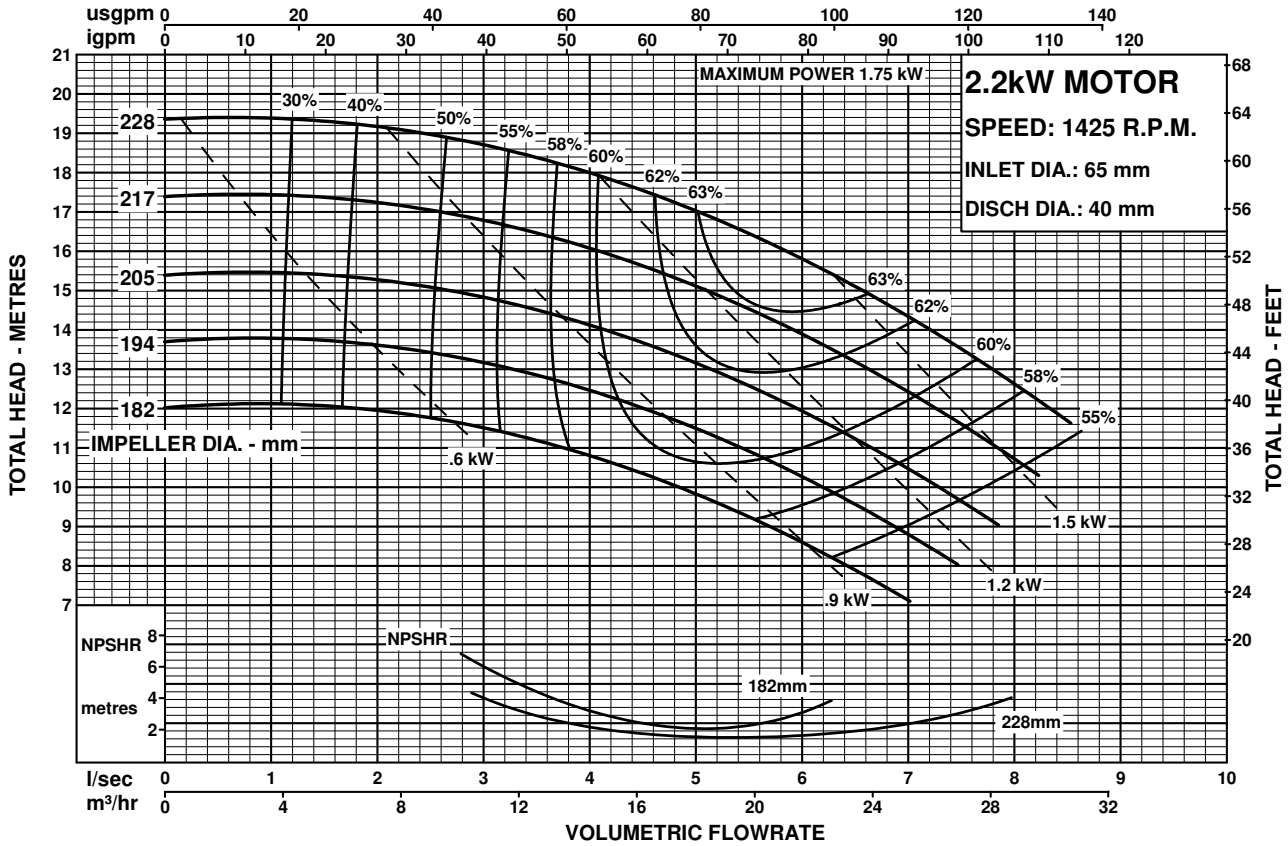

Performance to AS2417 Grade 2 for clean, cold water only.

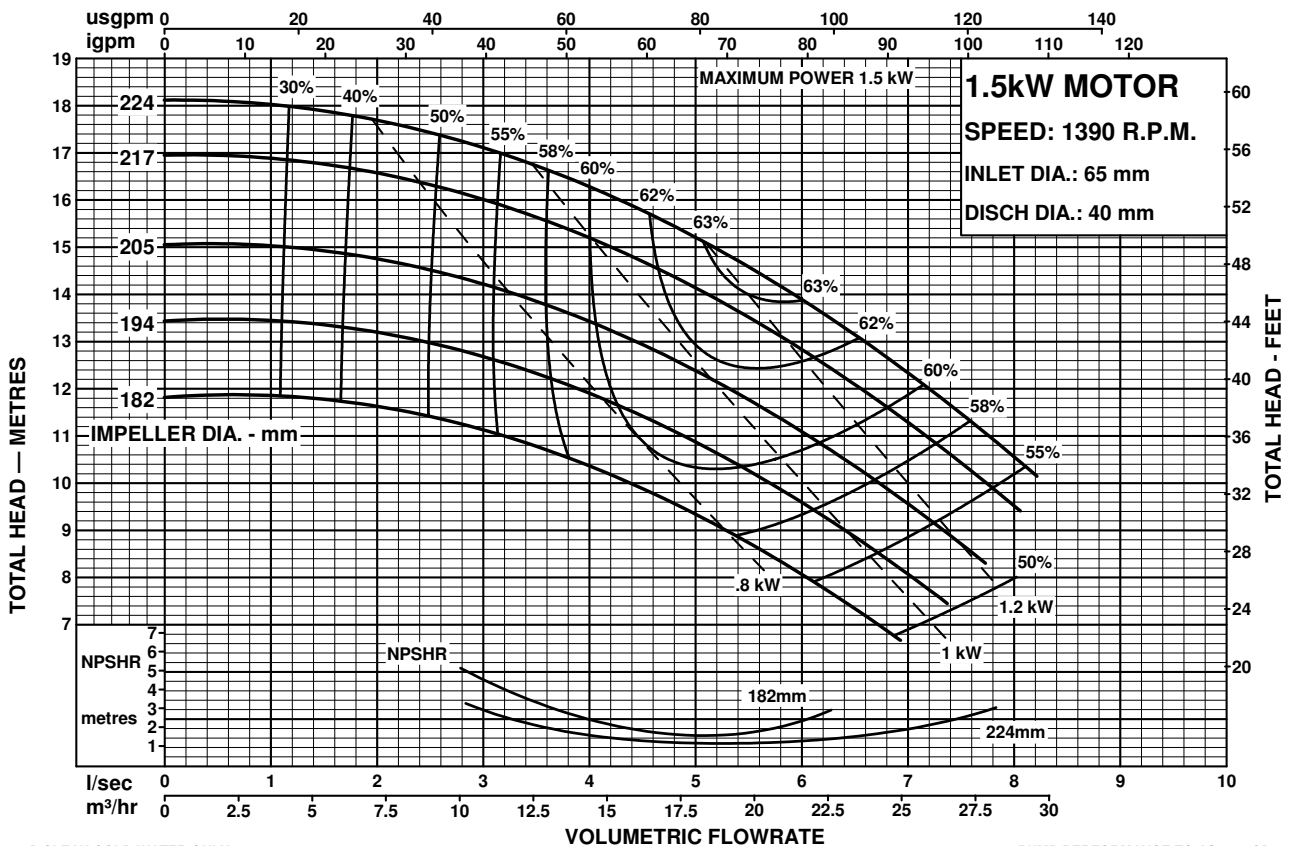

Performance to AS2417 Grade 2 for clean, cold water only.





# PENTAIR STARLINE

MOTORPUMPS  
50Hz PERFORMANCE

MODEL  
**65x40-200**

CENTRIFUGAL PUMP PERFORMANCE DATA

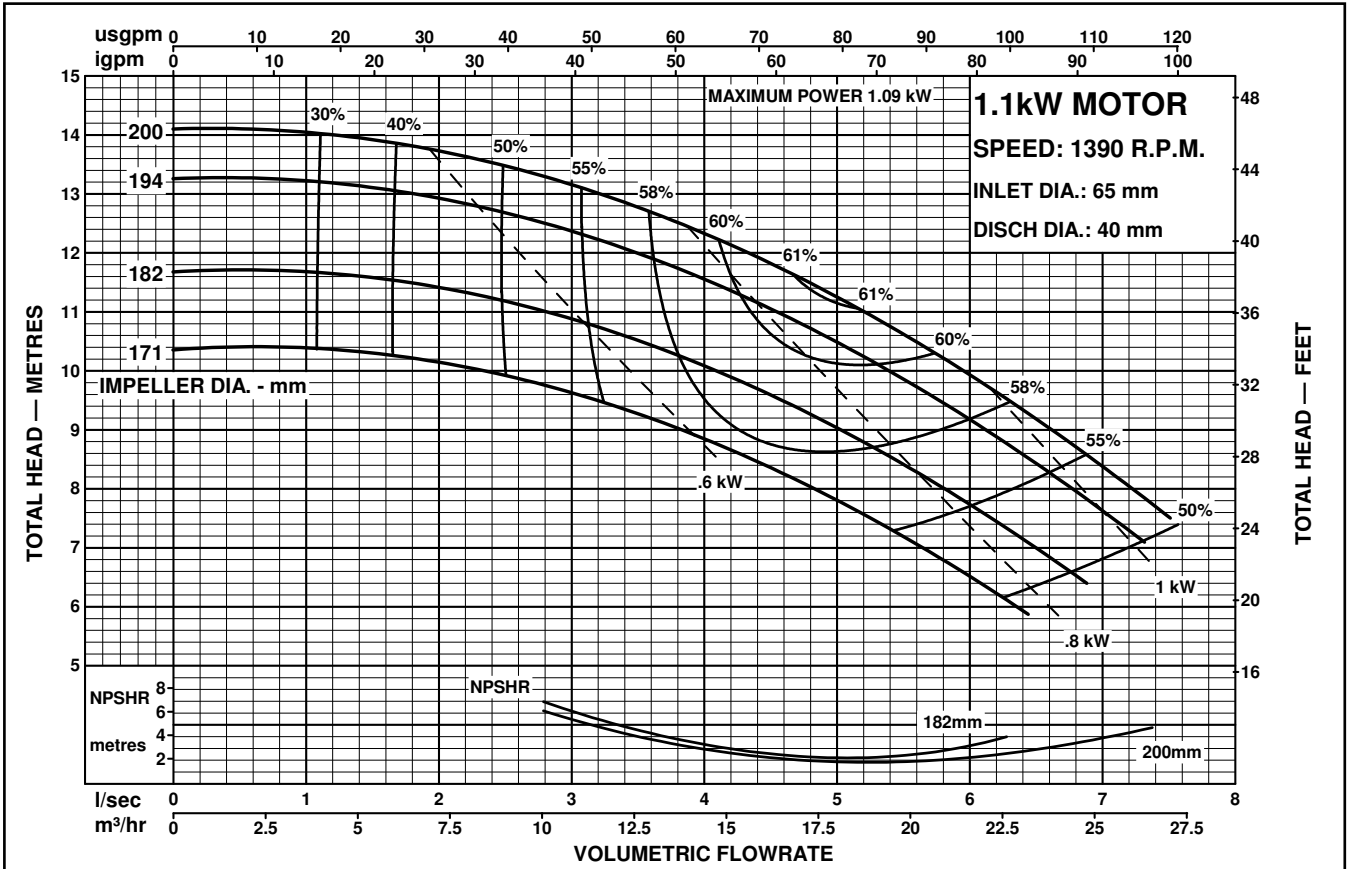

Performance to AS2417 Grade 2 for clean, cold water only.





# PENTAIR STARLINE

MOTORPUMPS  
50Hz PERFORMANCE

MODEL  
**65x40-200**

CENTRIFUGAL PUMP PERFORMANCE DATA

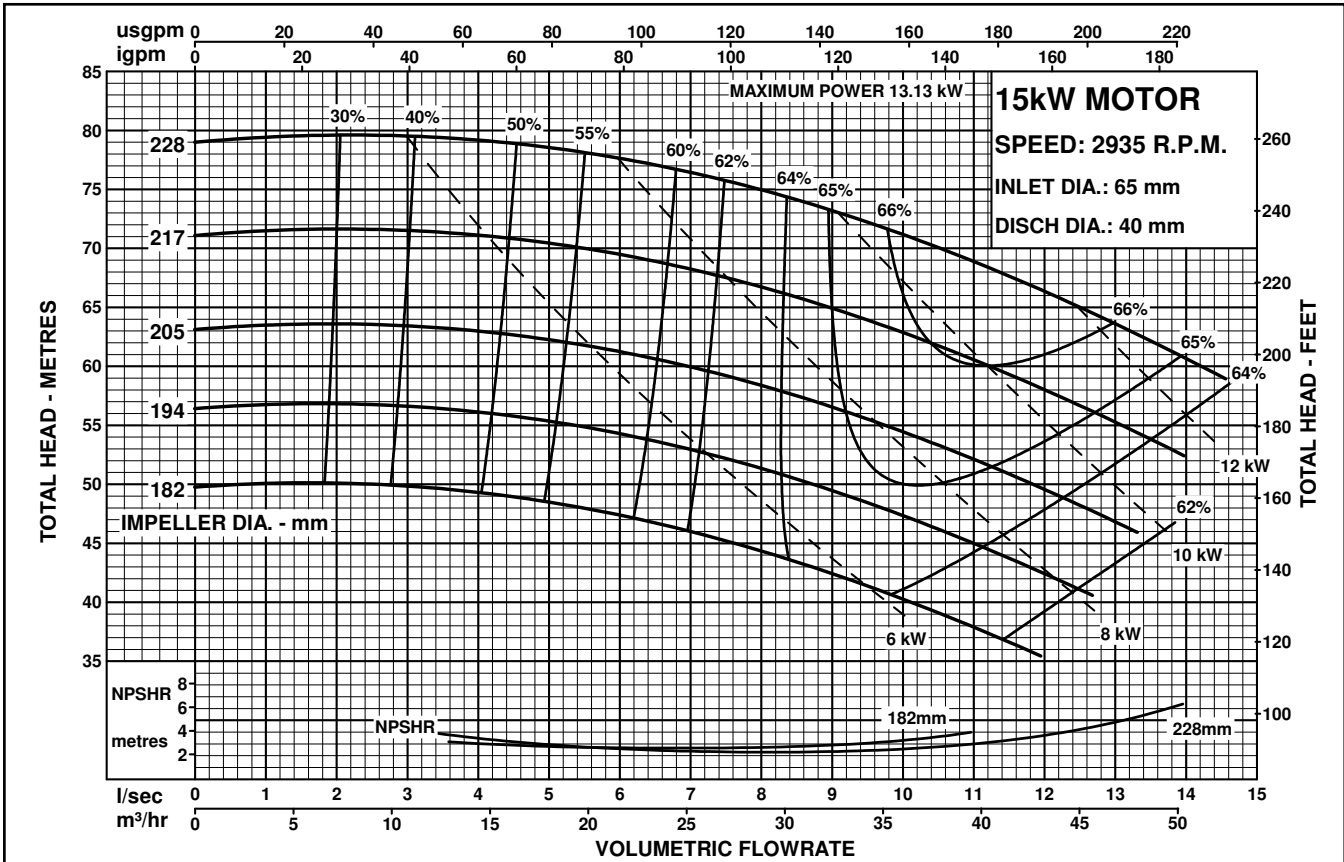

Performance to AS2417 Grade 2 for clean, cold water only.

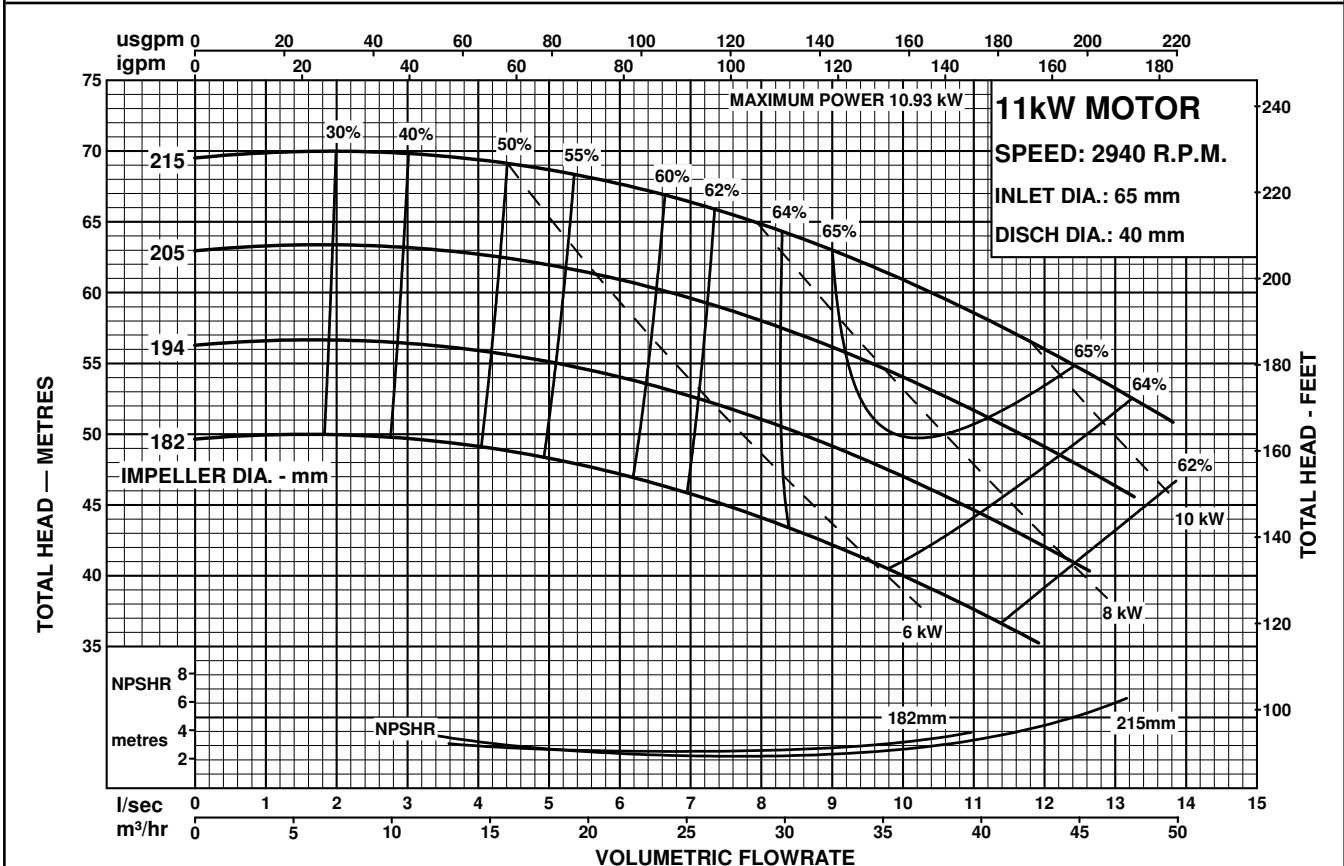

Performance to AS2417 Grade 2 for clean, cold water only.







# PENTAIR STARLINE

MOTORPUMPS  
50Hz PERFORMANCE

MODEL  
**65x40-200**

CENTRIFUGAL PUMP PERFORMANCE DATA

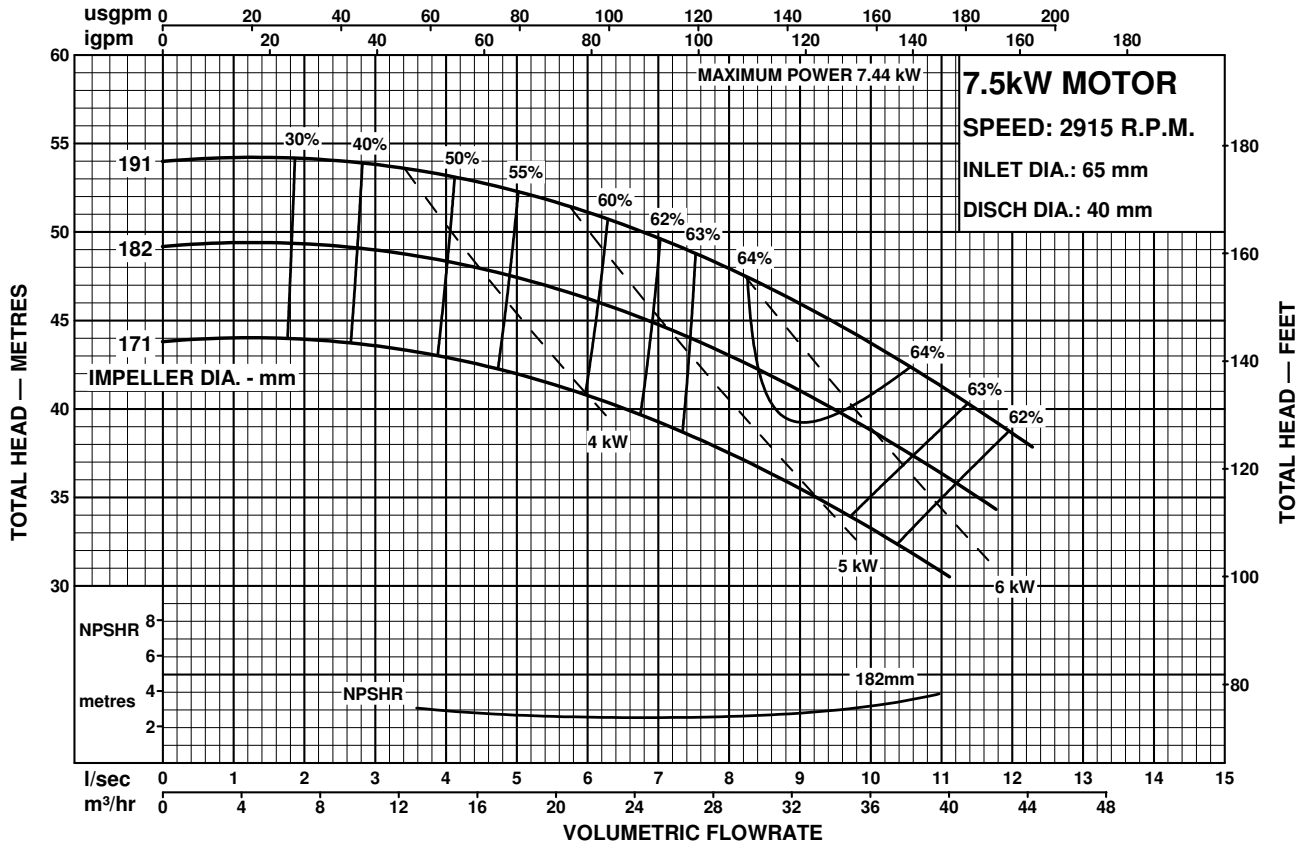

Performance to AS2417 Grade 2 for clean, cold water only.



# PENTAIR STARLINE

MOTORPUMPS  
50Hz PERFORMANCE

MODEL  
**65x40-250**

CENTRIFUGAL PUMP PERFORMANCE DATA

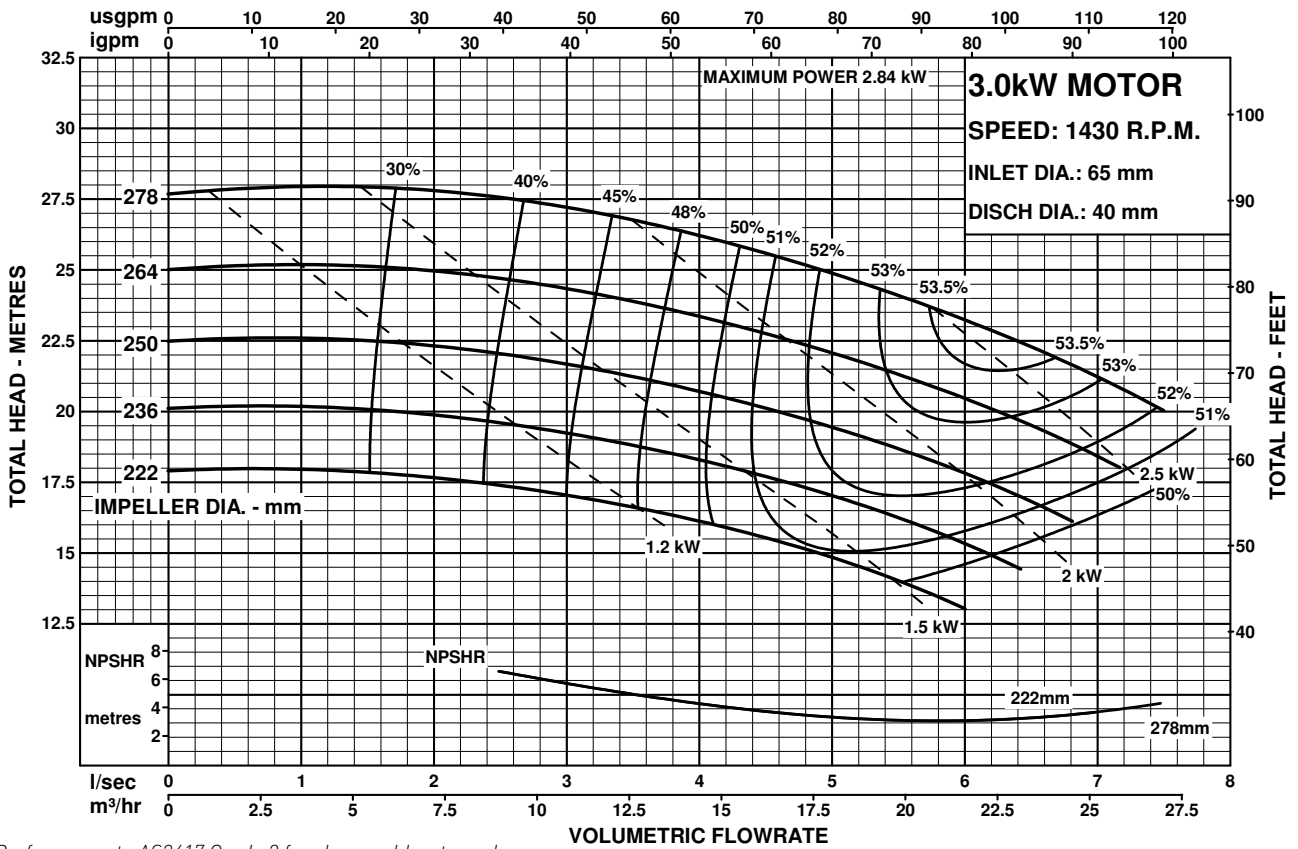

Performance to AS2417 Grade 2 for clean, cold water only.

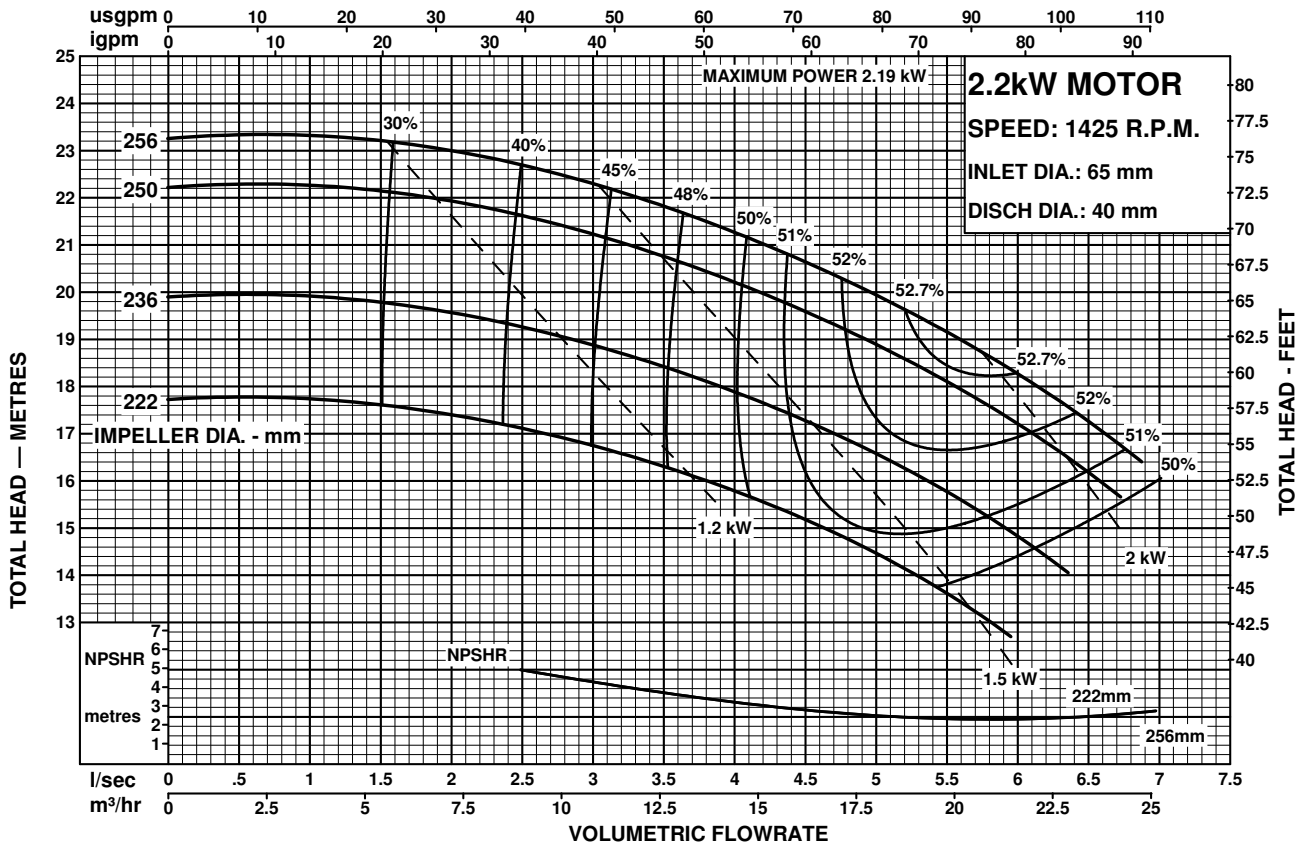

Performance to AS2417 Grade 2 for clean, cold water only.





# PENTAIR STARLINE

MOTORPUMPS  
50Hz PERFORMANCE

MODEL  
**65x40-250**

CENTRIFUGAL PUMP PERFORMANCE DATA

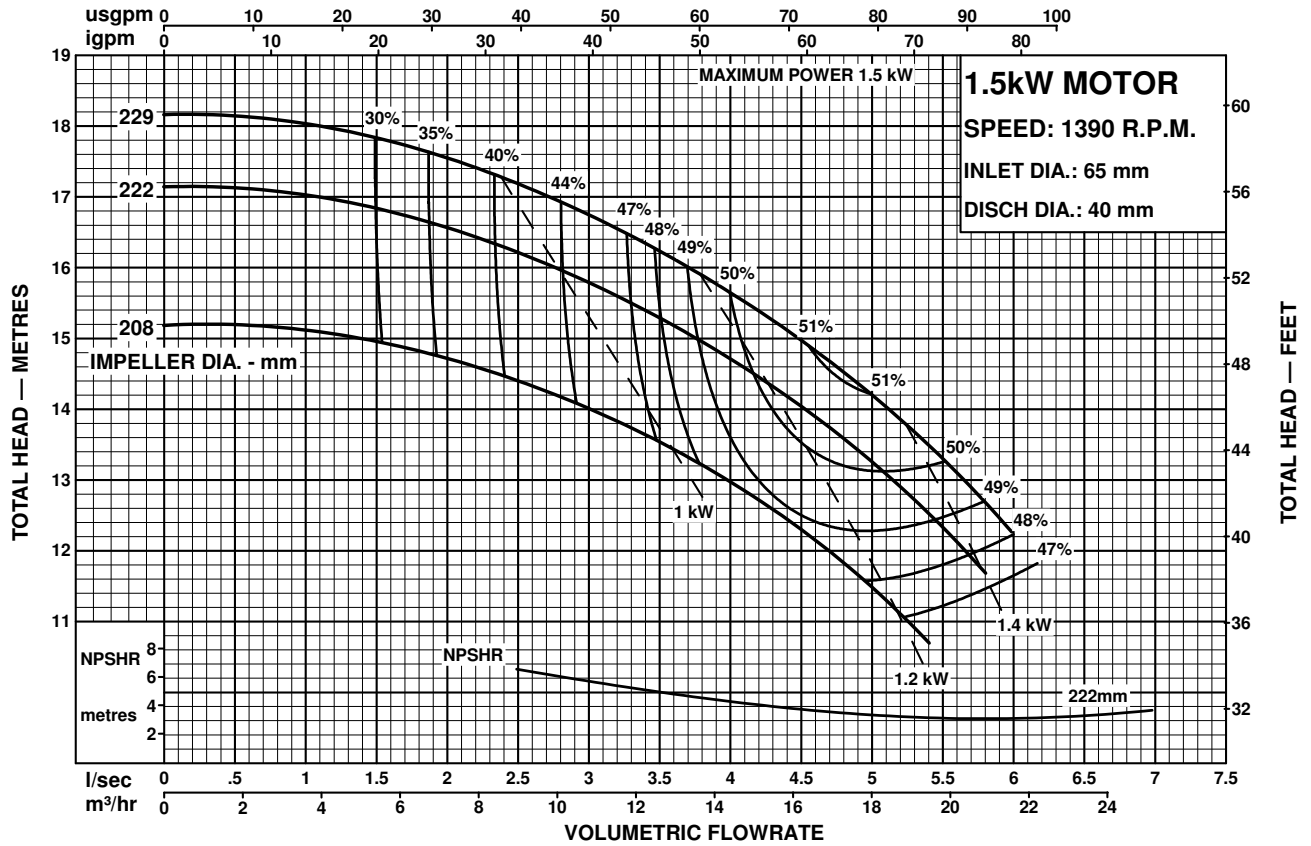

Performance to AS2417 Grade 2 for clean, cold water only.





# PENTAIR STARLINE

MOTORPUMPS  
50Hz PERFORMANCE

MODEL  
**65x40-250**

CENTRIFUGAL PUMP PERFORMANCE DATA

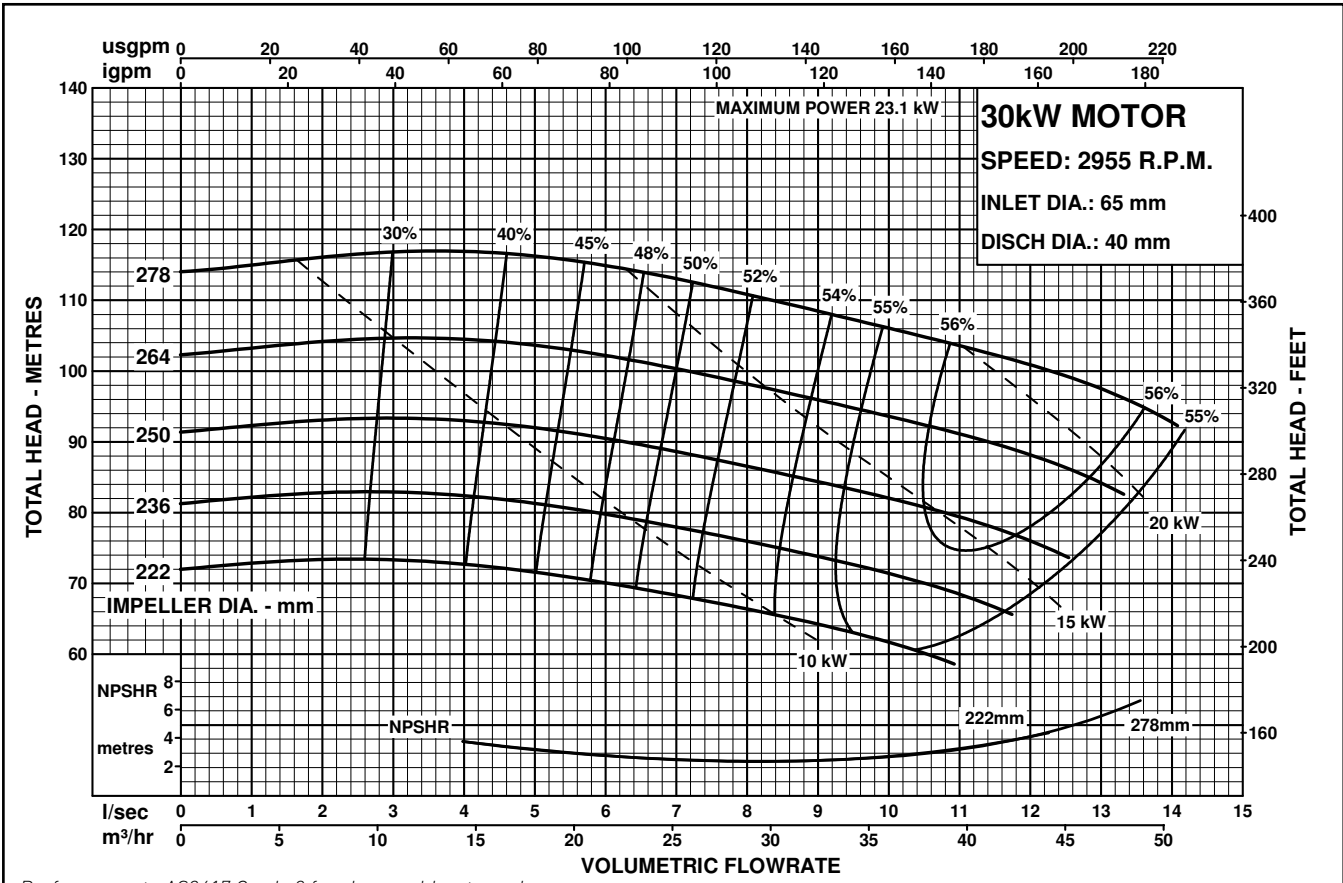

Performance to AS2417 Grade 2 for clean, cold water only.

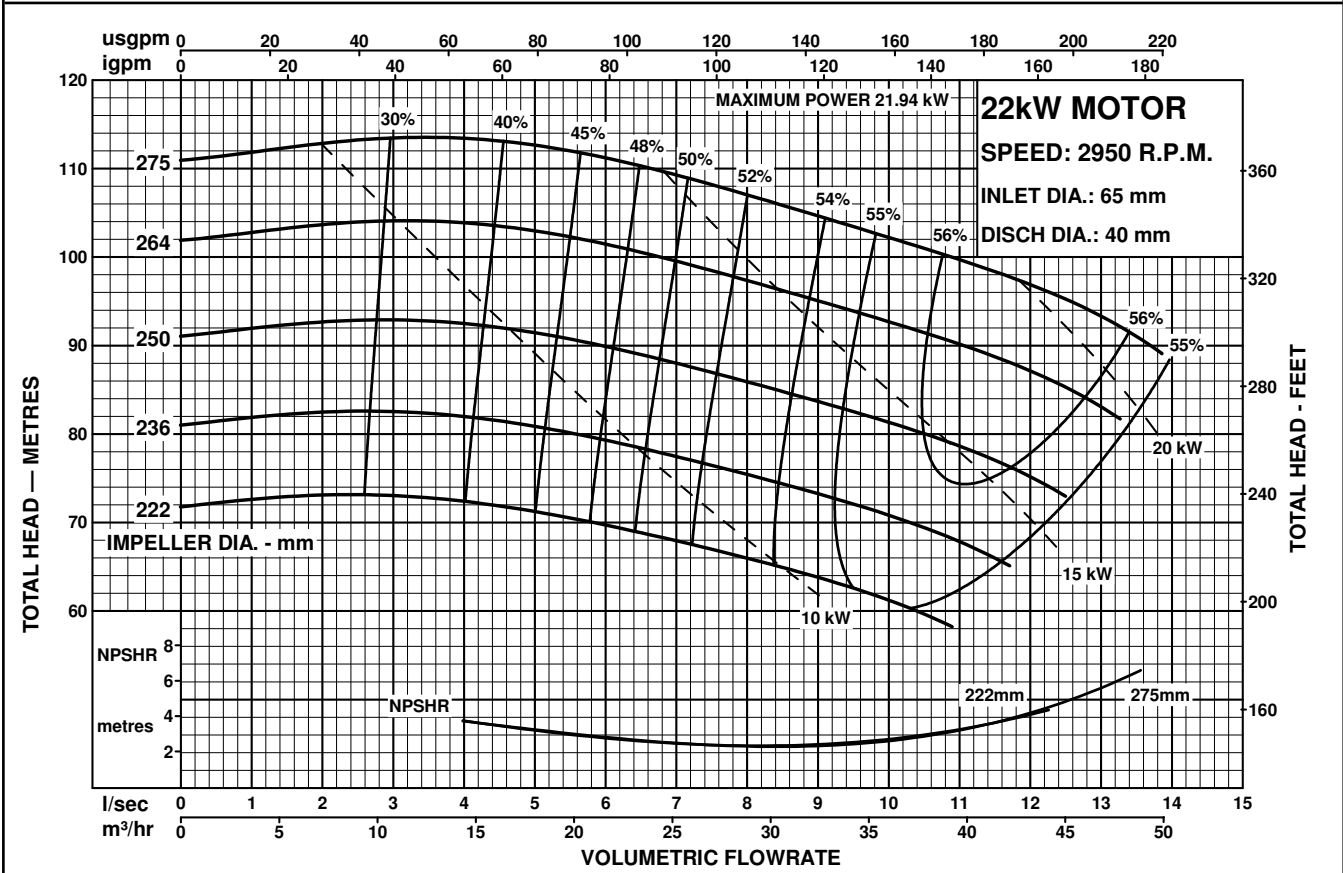

Performance to AS2417 Grade 2 for clean, cold water only.





# PENTAIR STARLINE

MOTORPUMPS

50Hz PERFORMANCE

MODEL  
**65x40-250**

CENTRIFUGAL PUMP PERFORMANCE DATA

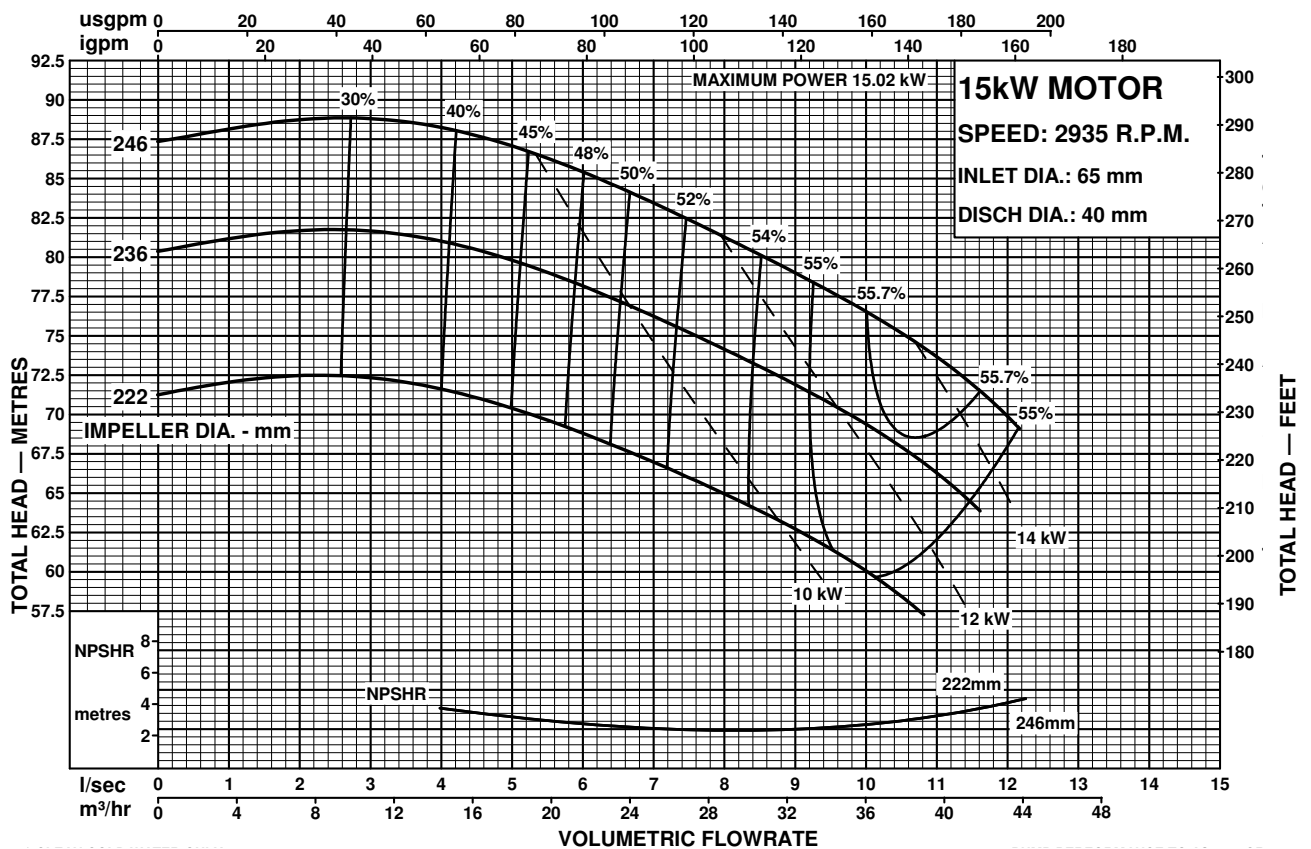
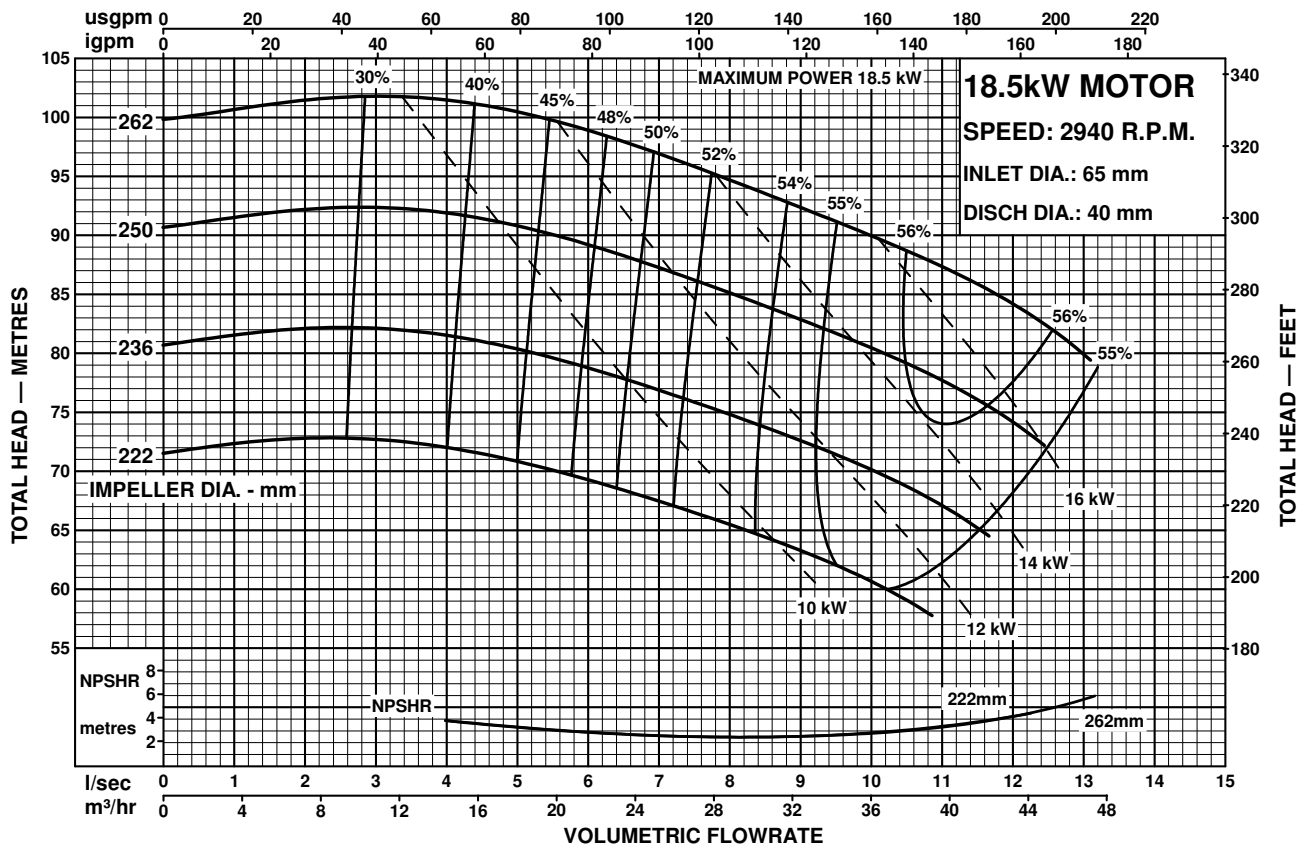



# PENTAIR STARLINE

MOTORPUMPS  
50Hz PERFORMANCE

MODEL  
**65x40-250**

CENTRIFUGAL PUMP PERFORMANCE DATA

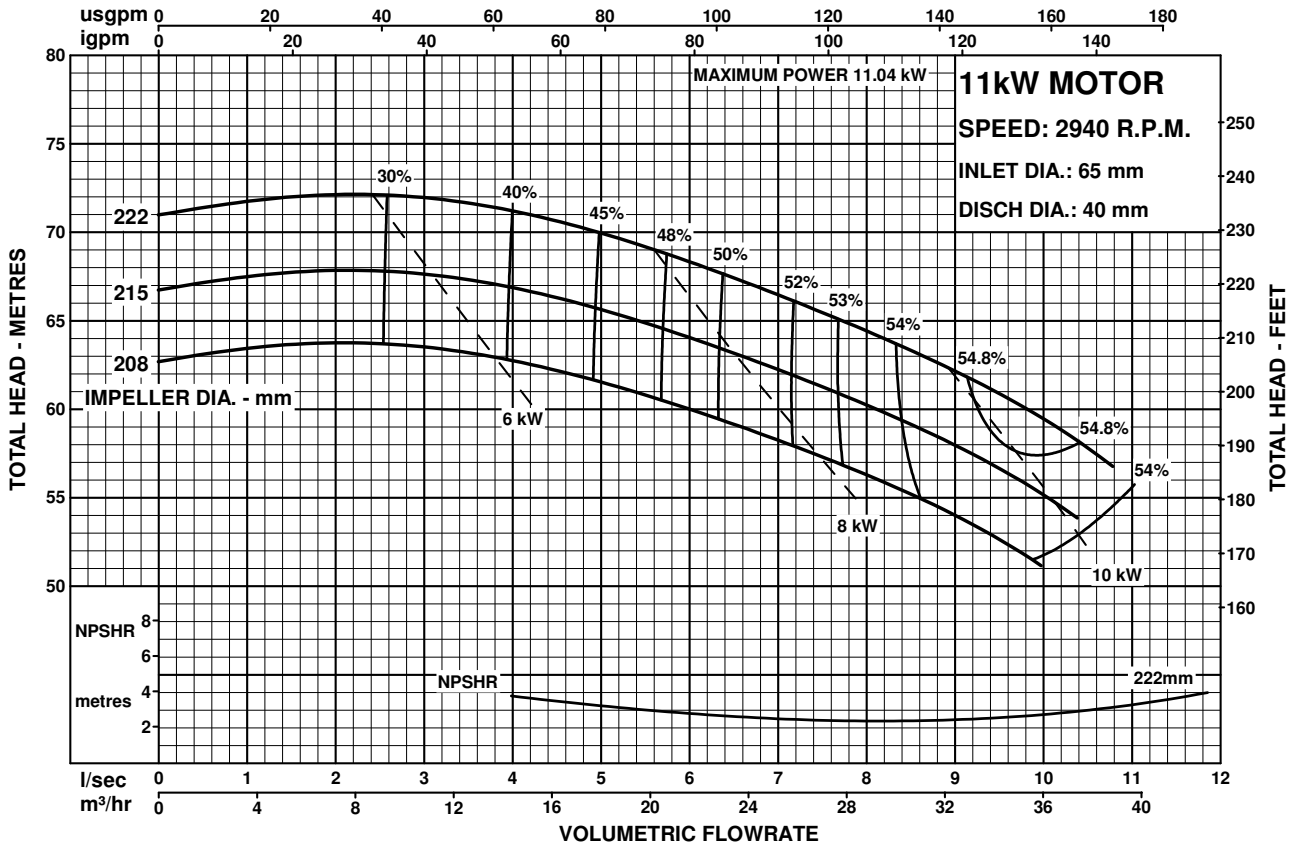

Performance to AS2417 Grade 2 for clean, cold water only.





# PENTAIR STARLINE

MOTORPUMPS

50Hz PERFORMANCE

## MODEL 65x40-315

CENTRIFUGAL PUMP PERFORMANCE DATA

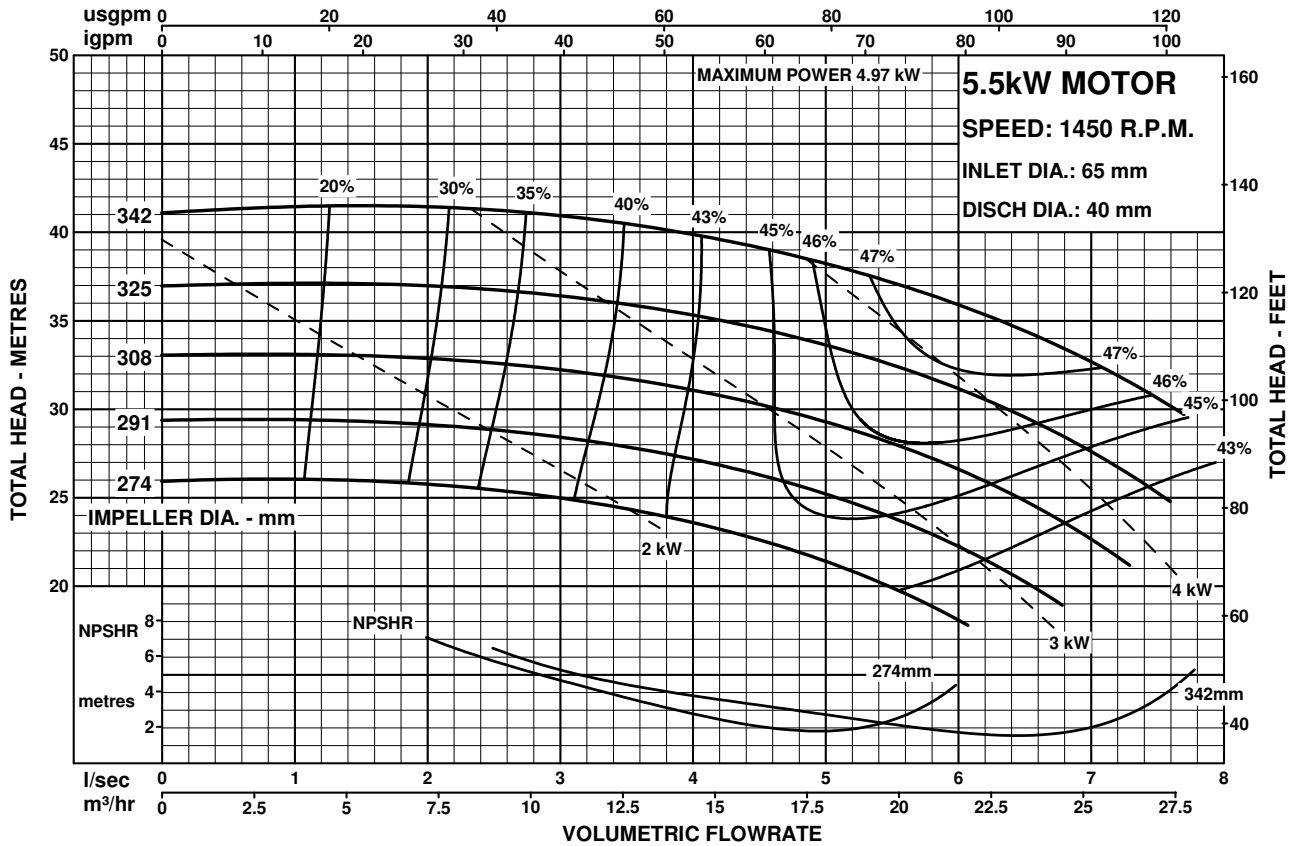

Performance to AS2417 Grade 2 for clean, cold water only.

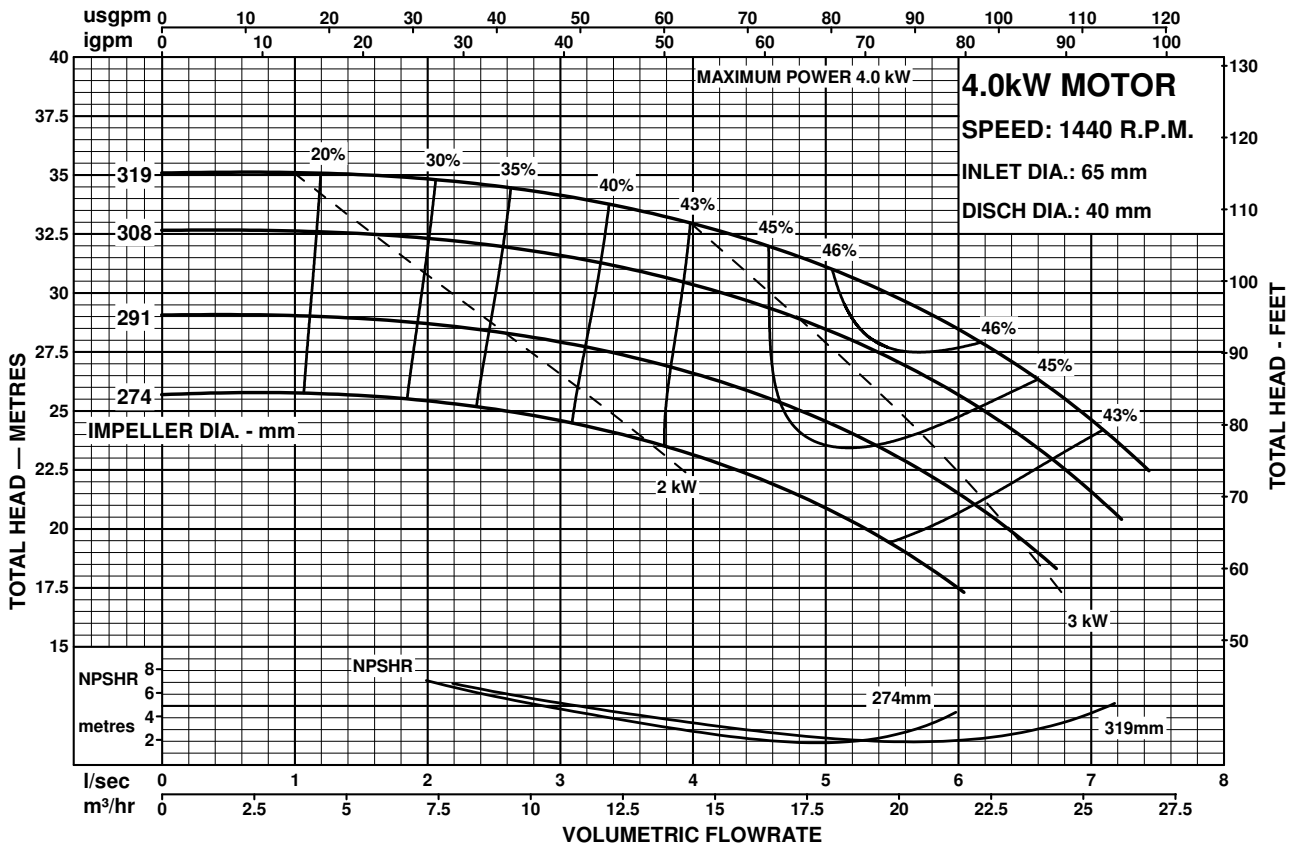

Performance to AS2417 Grade 2 for clean, cold water only.





# PENTAIR STARLINE

MOTORPUMPS  
50Hz PERFORMANCE

MODEL  
**65x40-315**

CENTRIFUGAL PUMP PERFORMANCE DATA

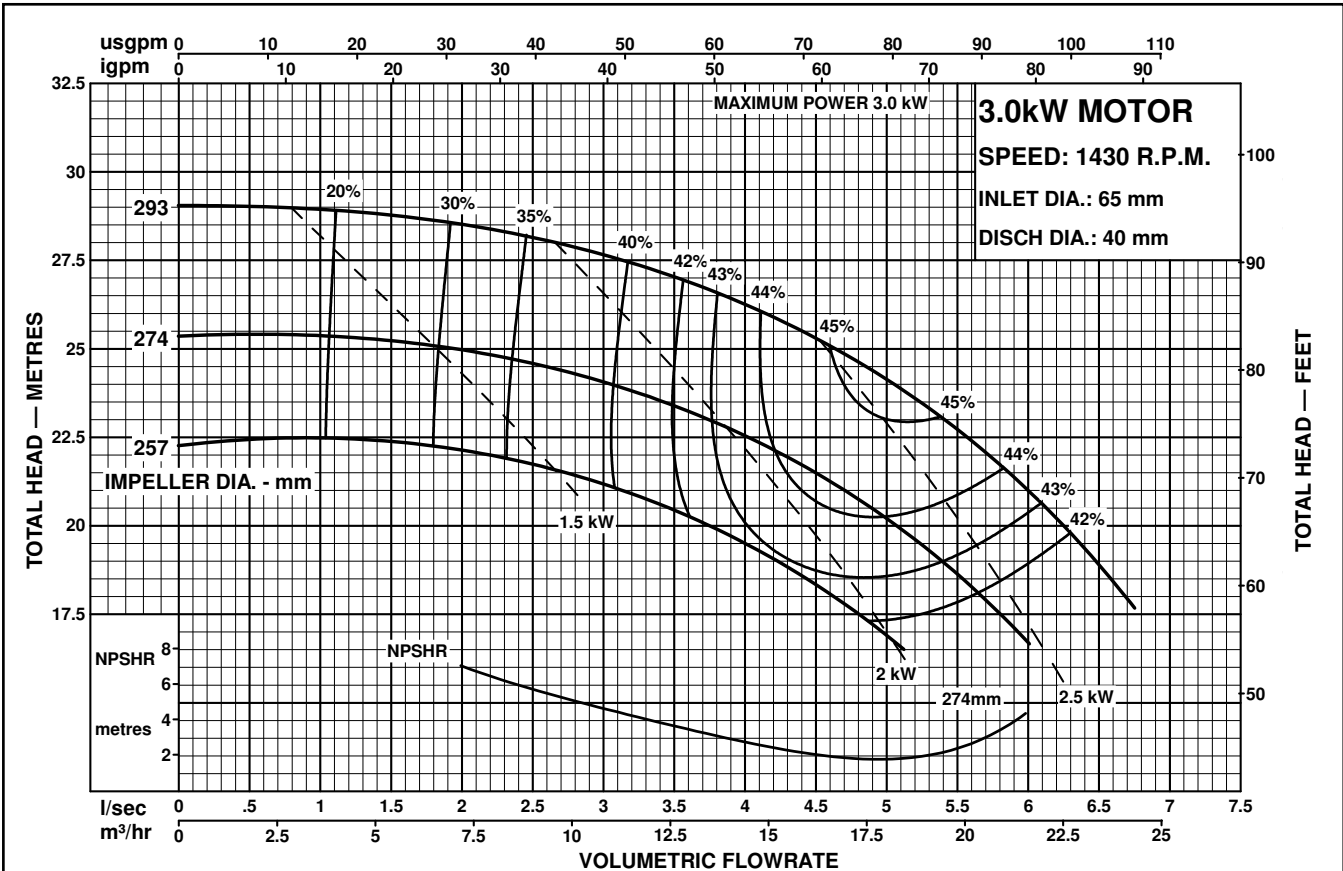

Performance to AS2417 Grade 2 for clean, cold water only.





# PENTAIR STARLINE

MOTORPUMPS

50Hz PERFORMANCE

MODEL  
**65x40-315**

CENTRIFUGAL PUMP PERFORMANCE DATA

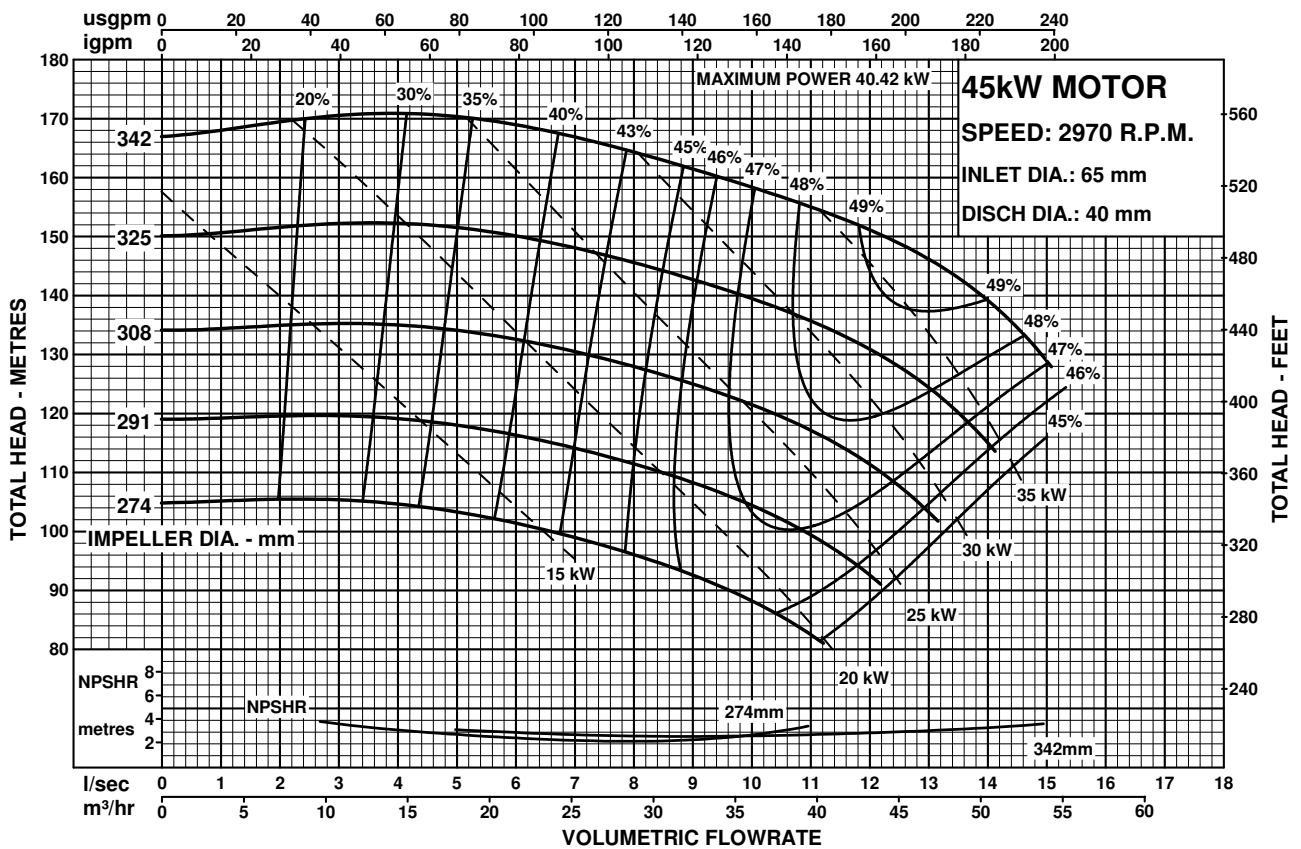

Performance to AS2417 Grade 2 for clean, cold water only.

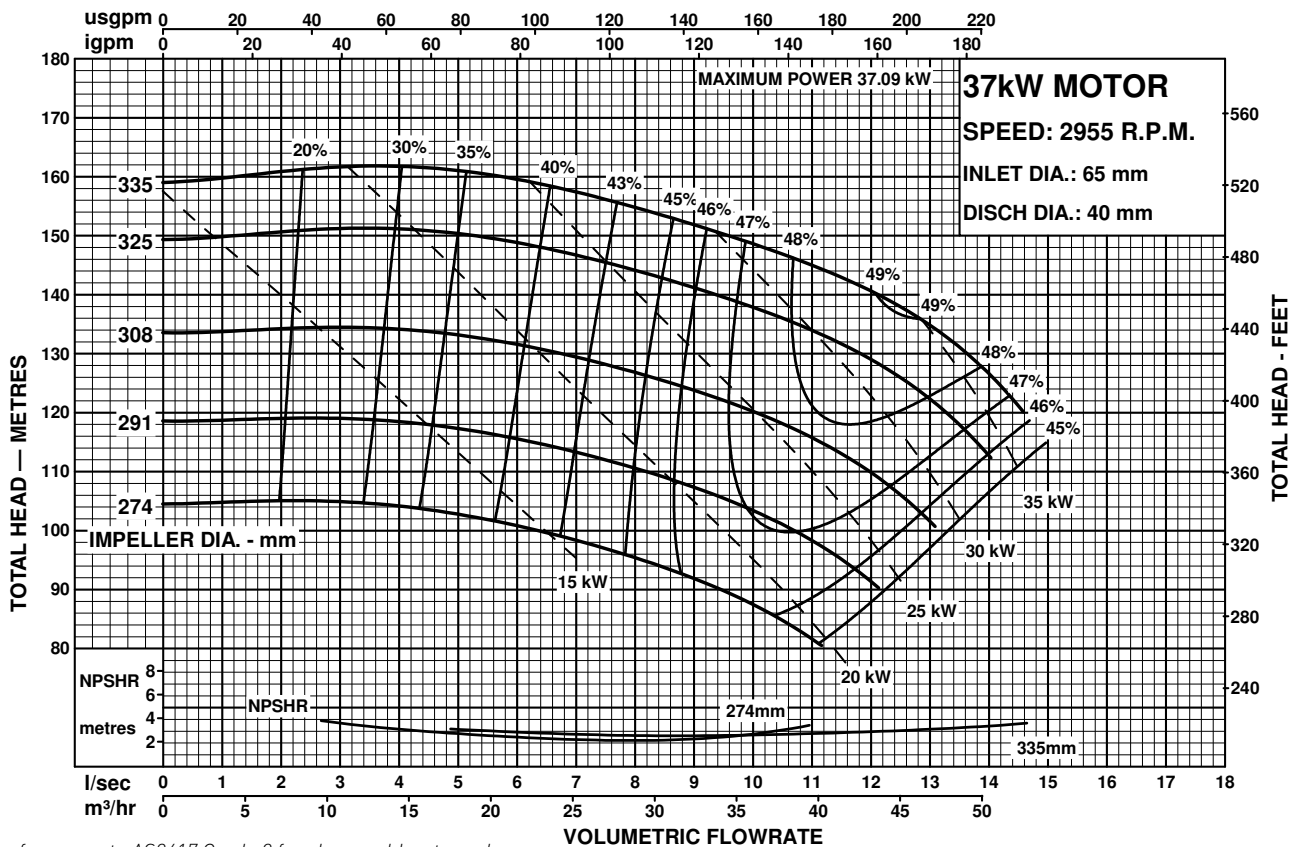

Performance to AS2417 Grade 2 for clean, cold water only.





# PENTAIR STARLINE

MOTORPUMPS  
50Hz PERFORMANCE

MODEL  
**65x40-315**

CENTRIFUGAL PUMP PERFORMANCE DATA

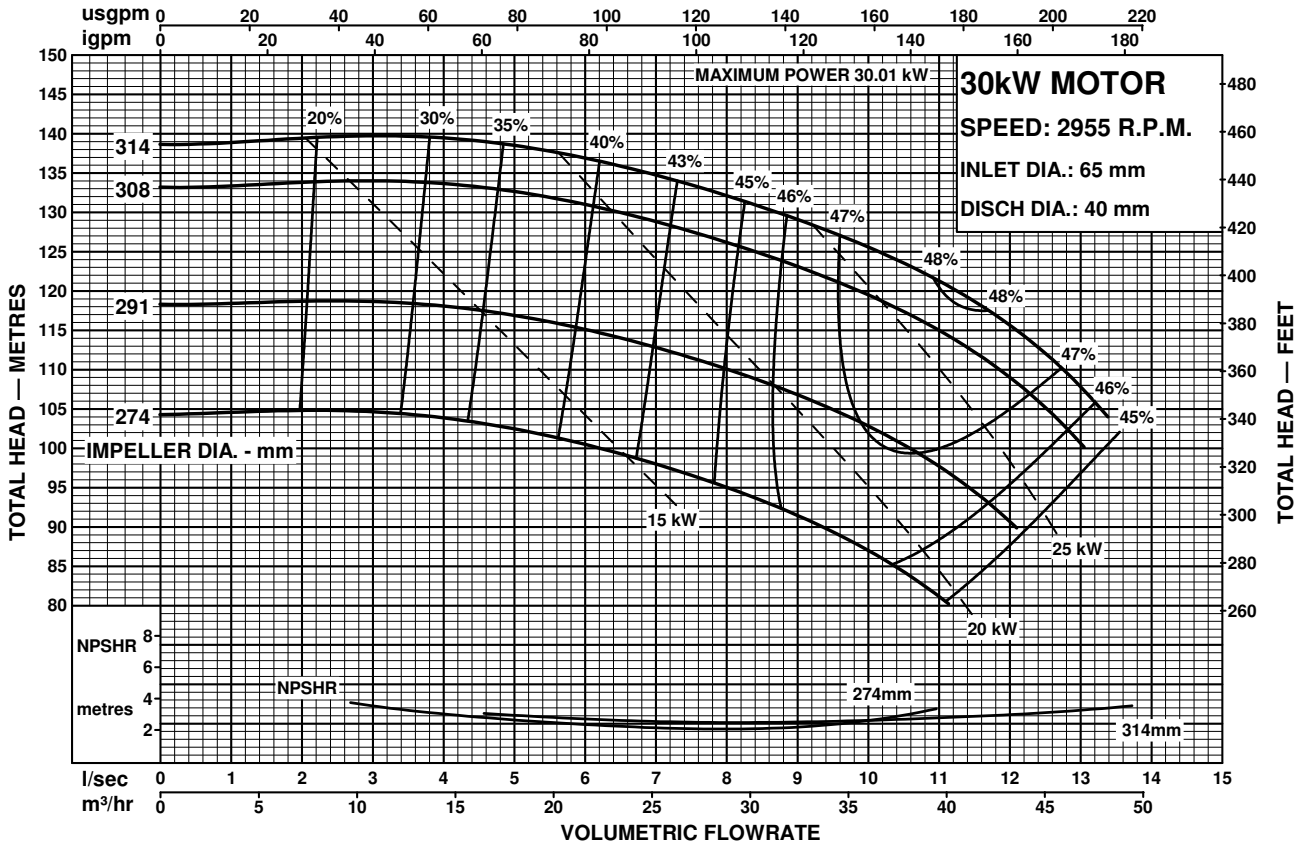

Performance to AS2417 Grade 2 for clean, cold water only.

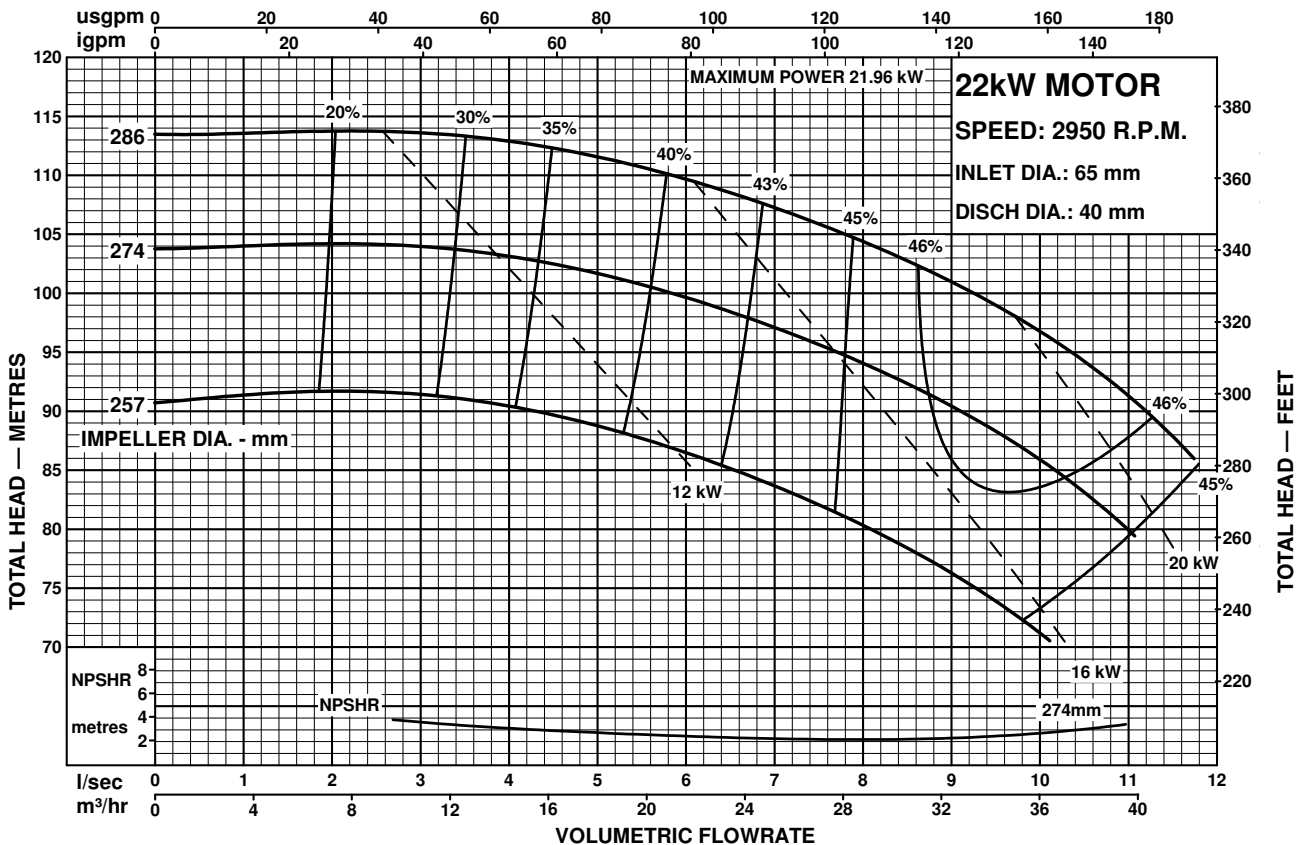

Performance to AS2417 Grade 2 for clean, cold water only.





# PENTAIR STARLINE

MOTORPUMPS

50Hz PERFORMANCE

## MODEL 80x65-160

### CENTRIFUGAL PUMP PERFORMANCE DATA

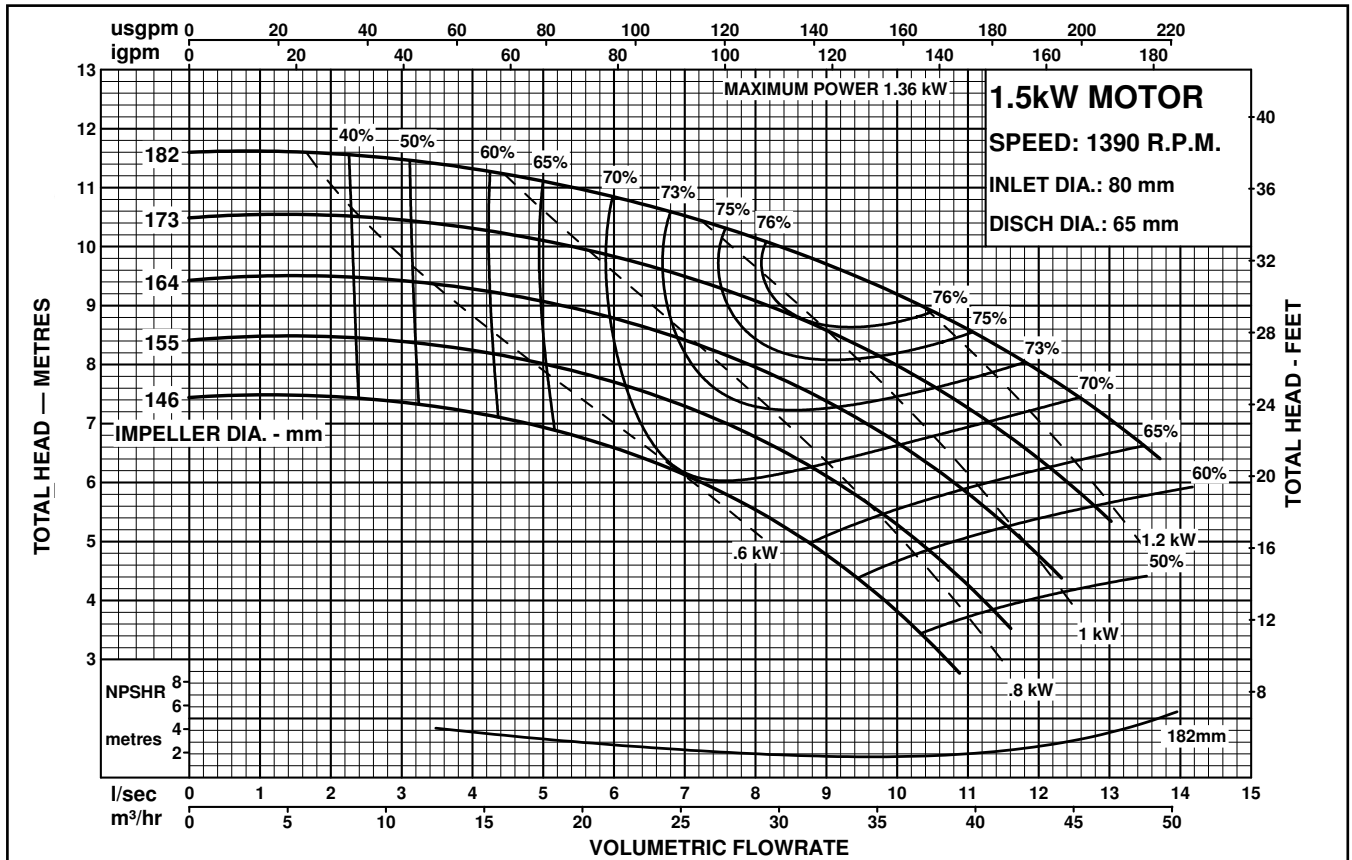

Performance to AS2417 Grade 2 for clean, cold water only.

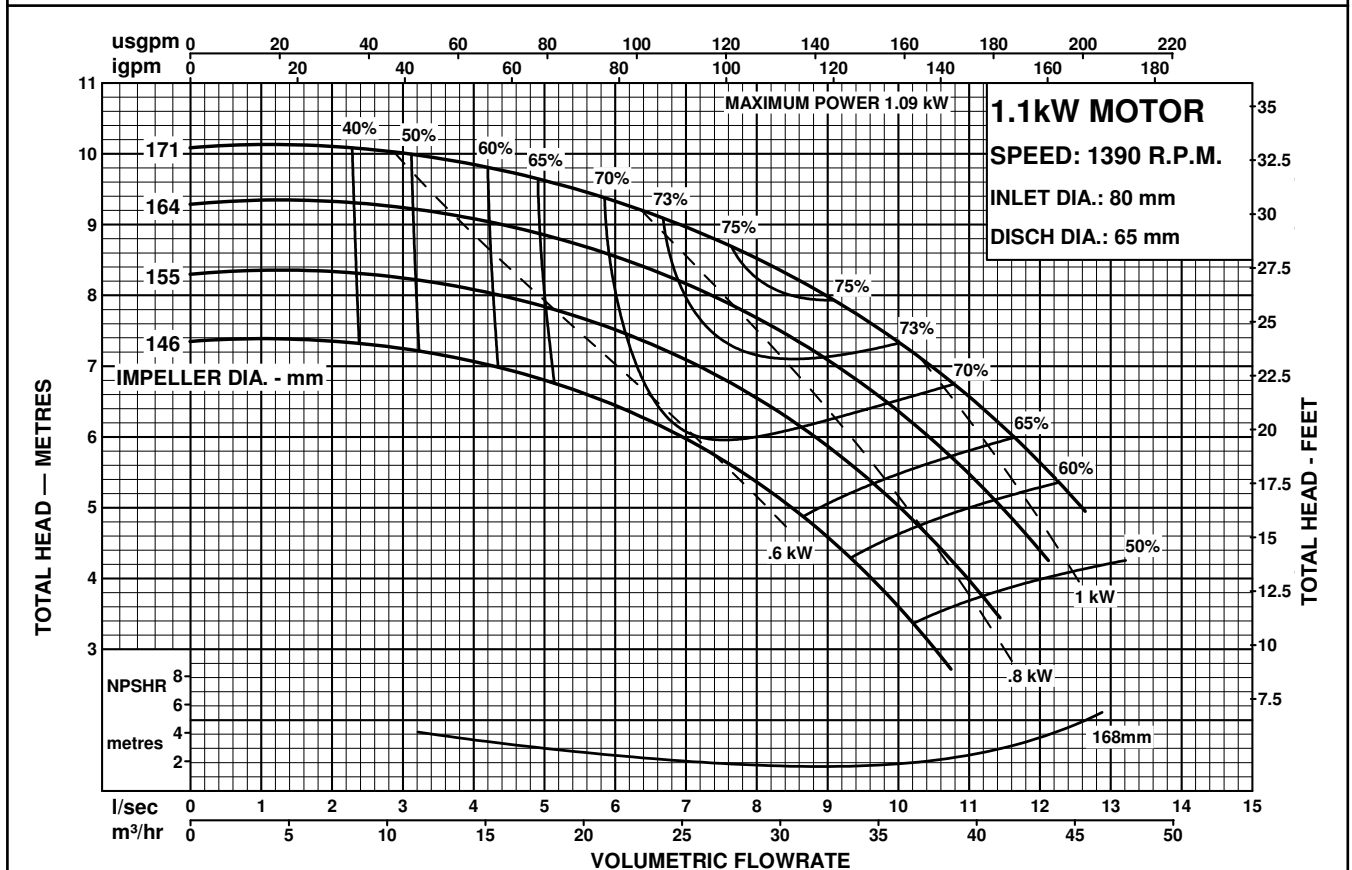

Performance to AS2417 Grade 2 for clean, cold water only.





# PENTAIR STARLINE

MOTORPUMPS  
50Hz PERFORMANCE

MODEL  
**80x65-160**

CENTRIFUGAL PUMP PERFORMANCE DATA

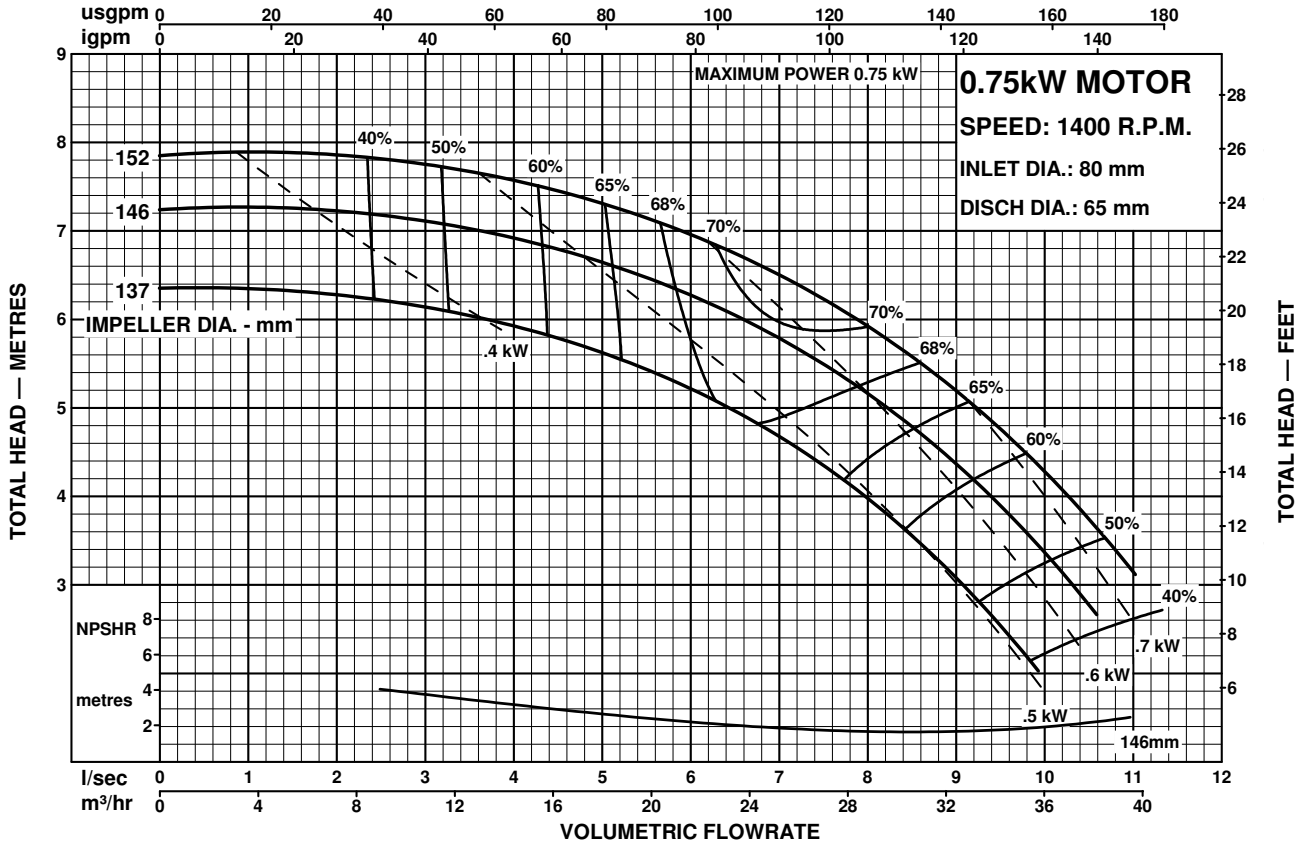

Performance to AS2417 Grade 2 for clean, cold water only.



# PENTAIR STARLINE

MOTORPUMPS

50Hz PERFORMANCE

## MODEL 80x65-160

CENTRIFUGAL PUMP PERFORMANCE DATA

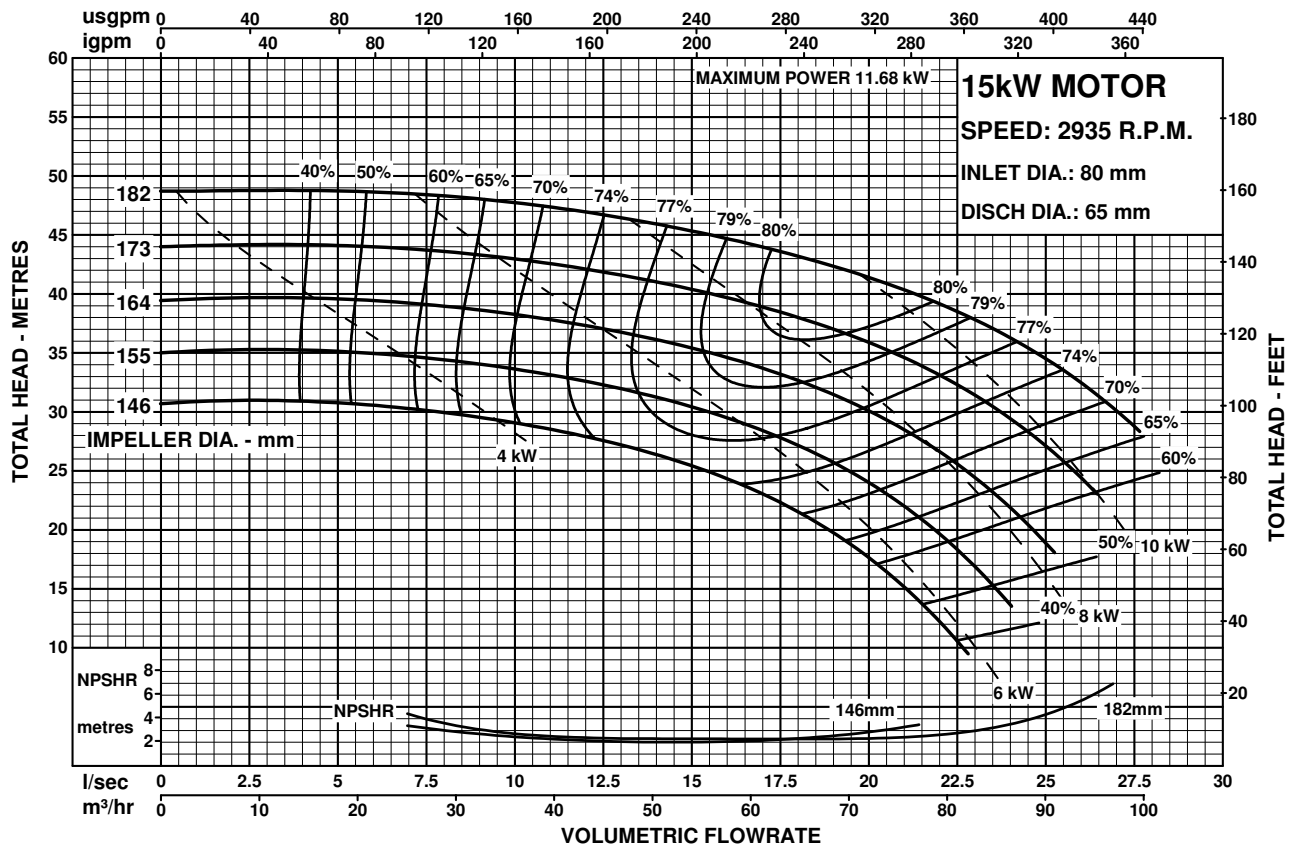

Performance to AS2417 Grade 2 for clean, cold water only.

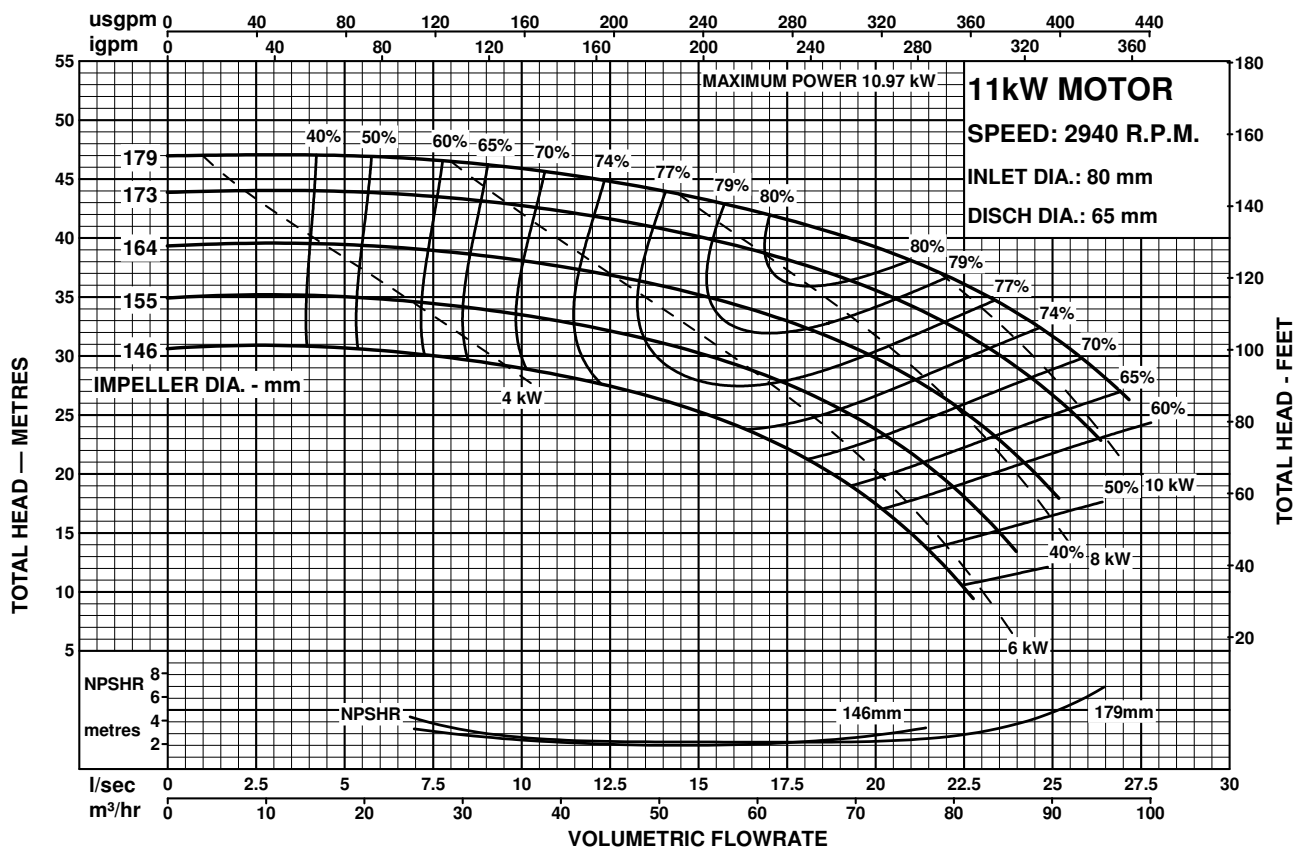

Performance to AS2417 Grade 2 for clean, cold water only.





# PENTAIR STARLINE

MOTORPUMPS  
50Hz PERFORMANCE

MODEL  
**80x65-160**

CENTRIFUGAL PUMP PERFORMANCE DATA

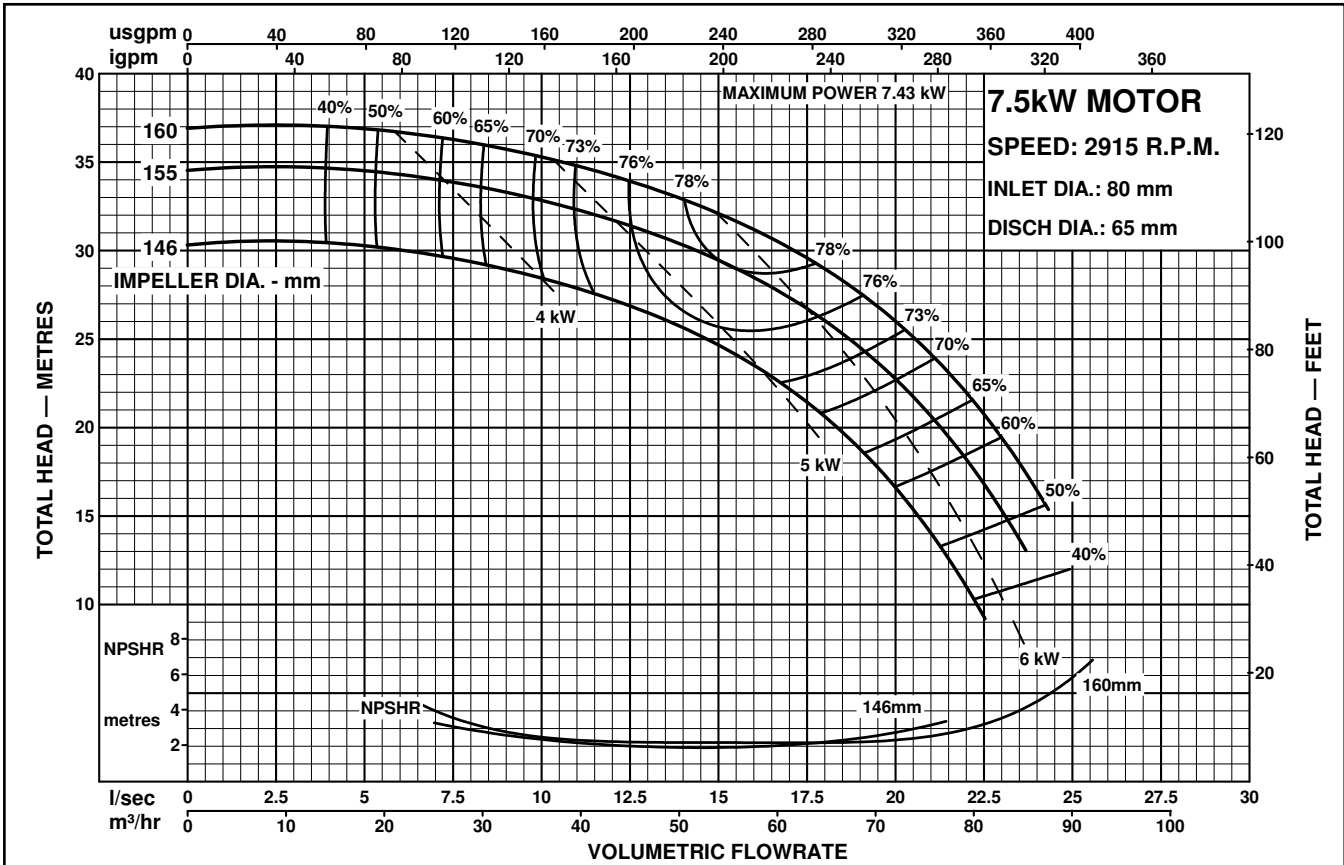

Performance to AS2417 Grade 2 for clean, cold water only.

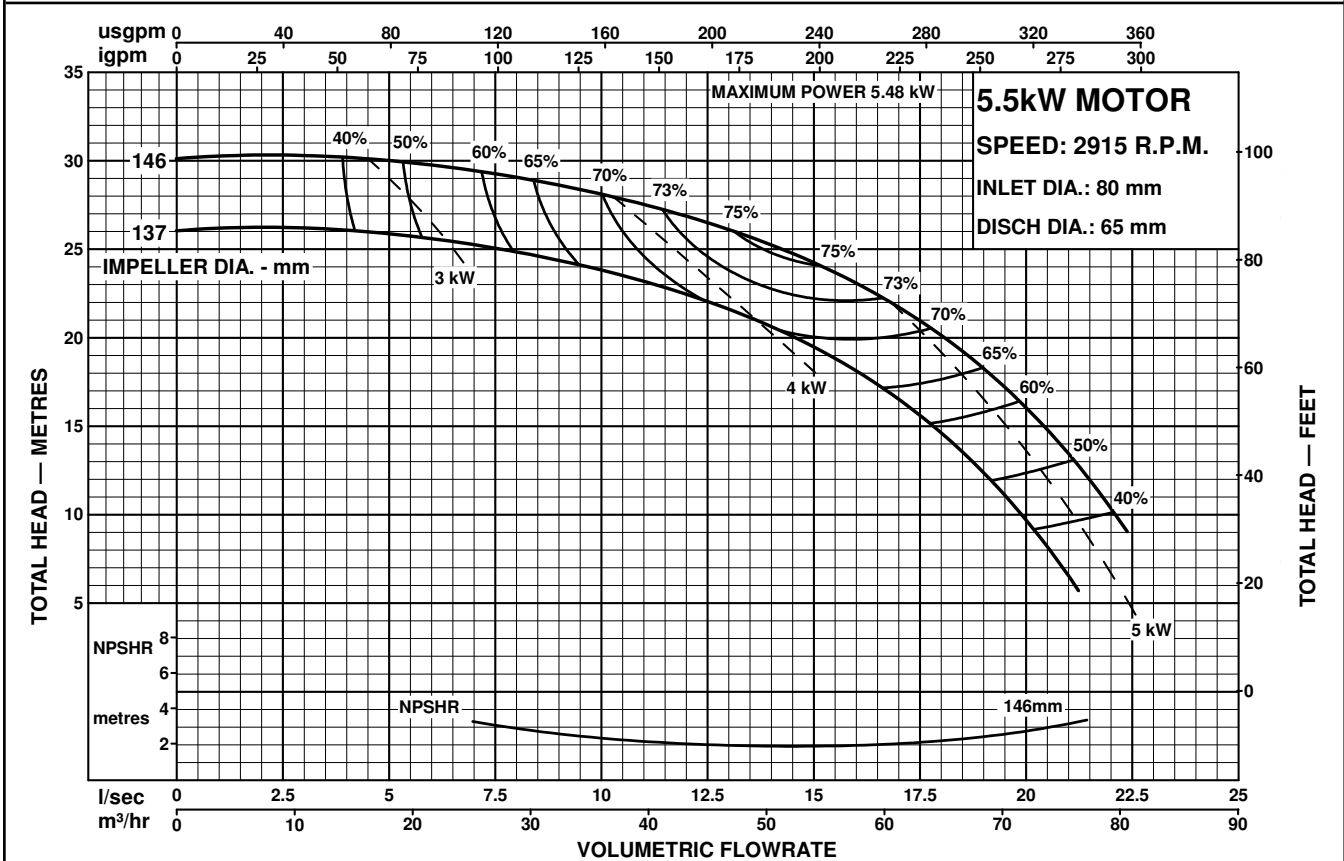

Performance to AS2417 Grade 2 for clean, cold water only.





# PENTAIR STARLINE

MOTORPUMPS

50Hz PERFORMANCE

## MODEL 80x50-200

CENTRIFUGAL PUMP PERFORMANCE DATA

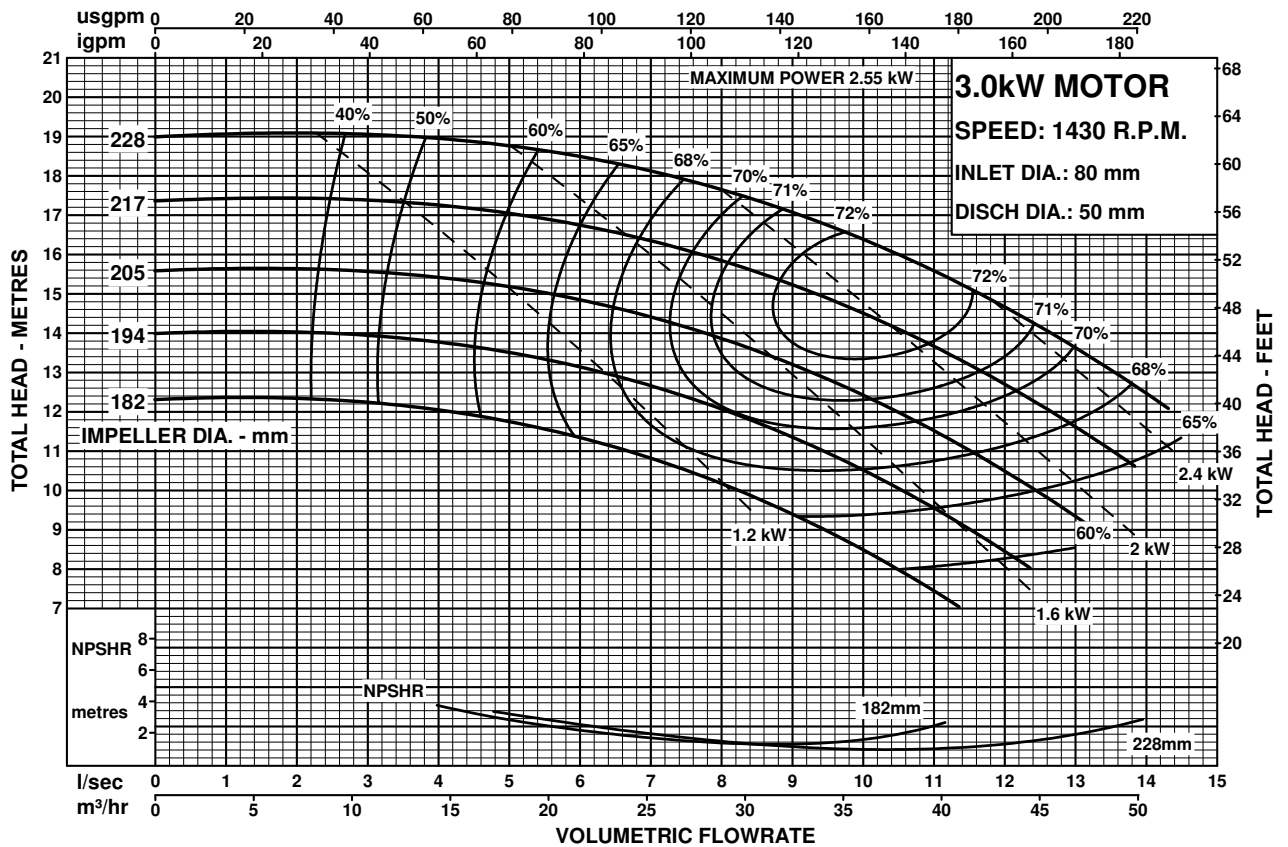

Performance to AS2417 Grade 2 for clean, cold water only.

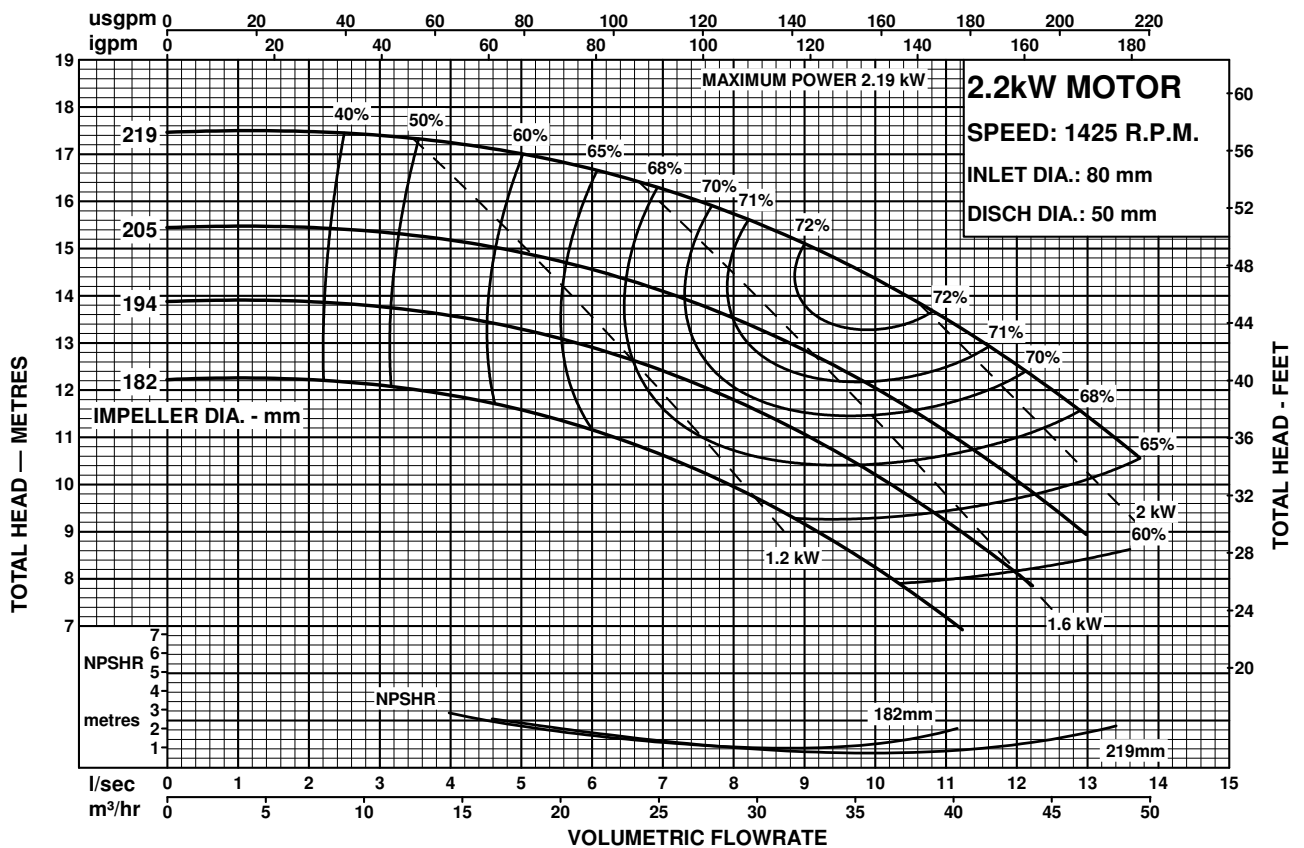

Performance to AS2417 Grade 2 for clean, cold water only.





# PENTAIR STARLINE

MOTORPUMPS

50Hz PERFORMANCE

MODEL  
**80x50-200**

CENTRIFUGAL PUMP PERFORMANCE DATA

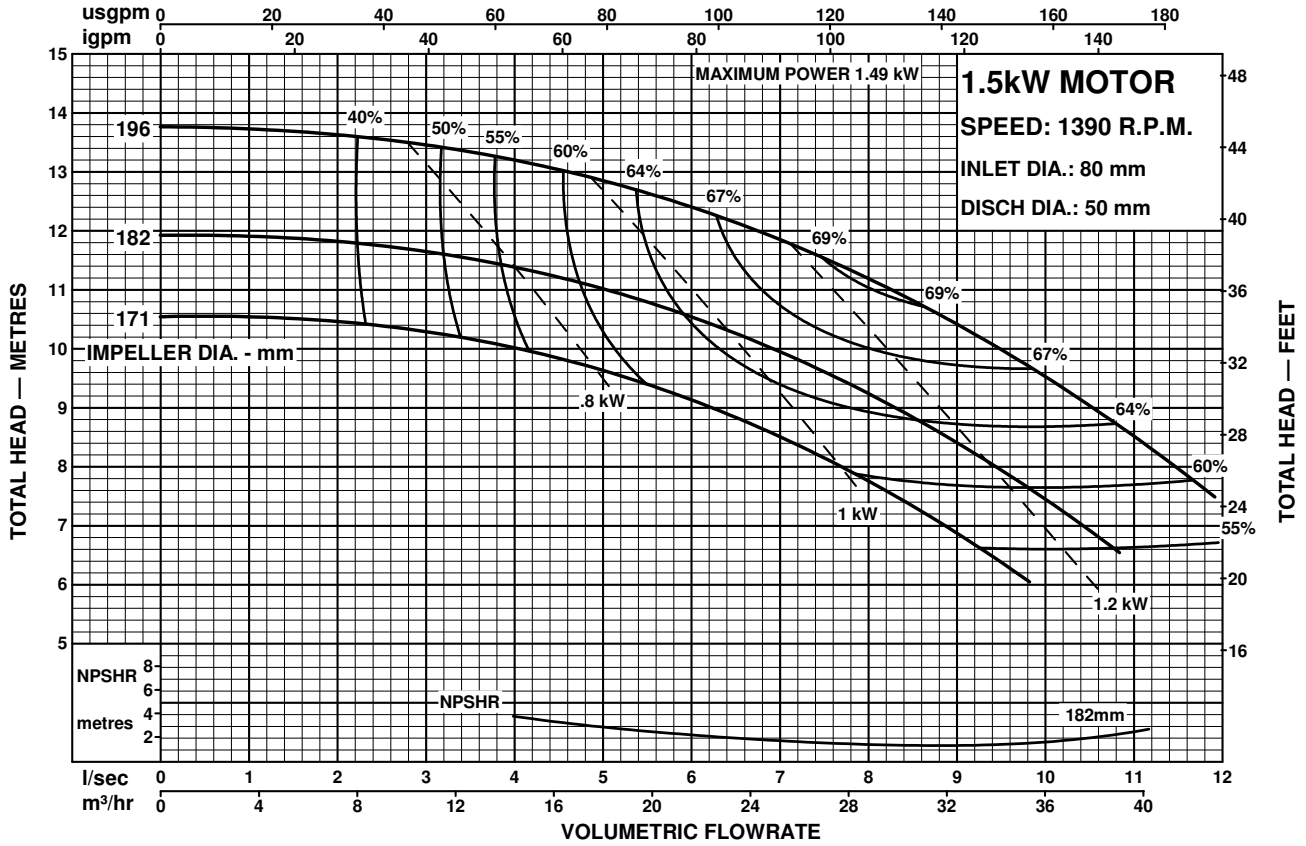

Performance to AS2417 Grade 2 for clean, cold water only.





# PENTAIR STARLINE

MOTORPUMPS

50Hz PERFORMANCE

## MODEL 80x50-200

CENTRIFUGAL PUMP PERFORMANCE DATA

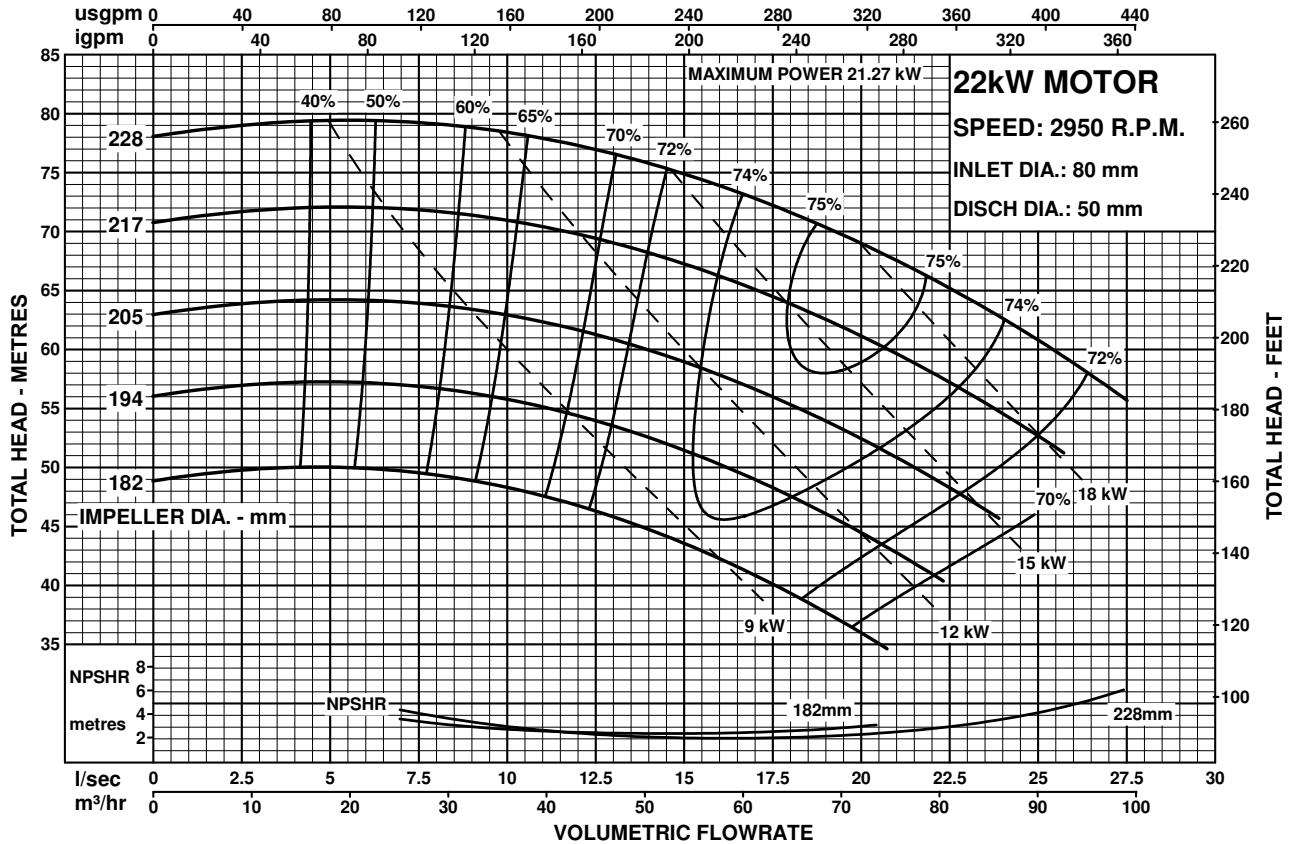

Performance to AS2417 Grade 2 for clean, cold water only.

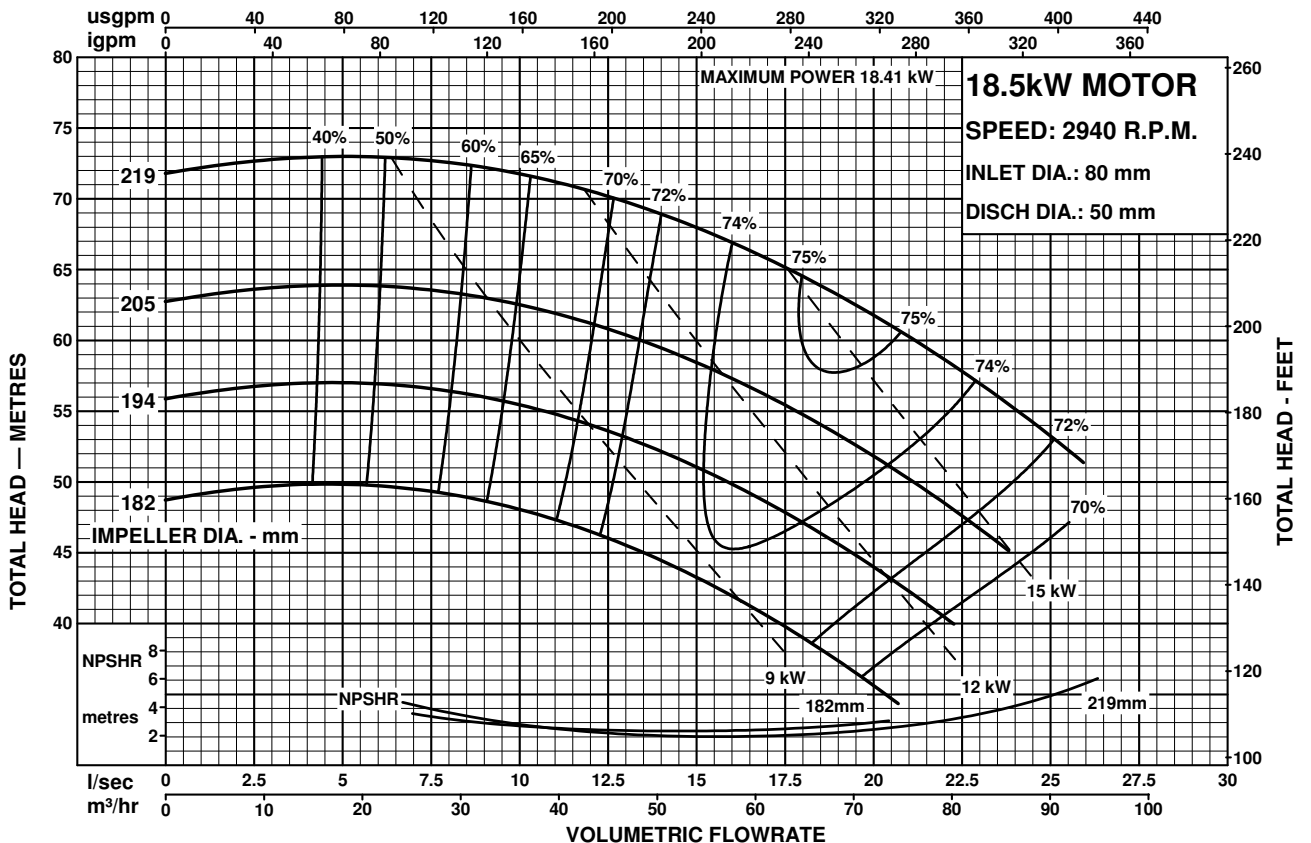

Performance to AS2417 Grade 2 for clean, cold water only.





# PENTAIR STARLINE

MOTORPUMPS  
50Hz PERFORMANCE

MODEL  
**80x50-200**

CENTRIFUGAL PUMP PERFORMANCE DATA

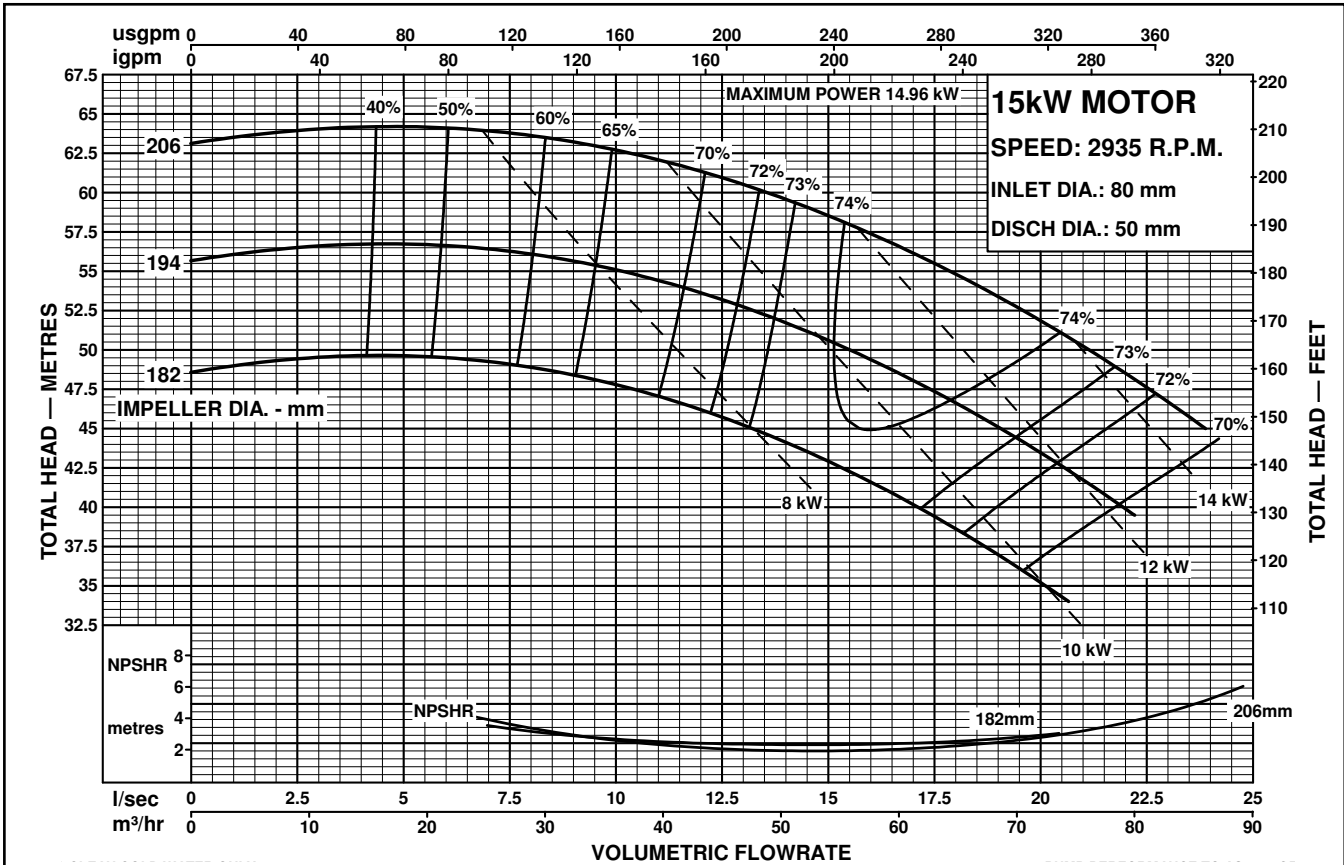

Performance to AS2417 Grade 2 for clean, cold water only.

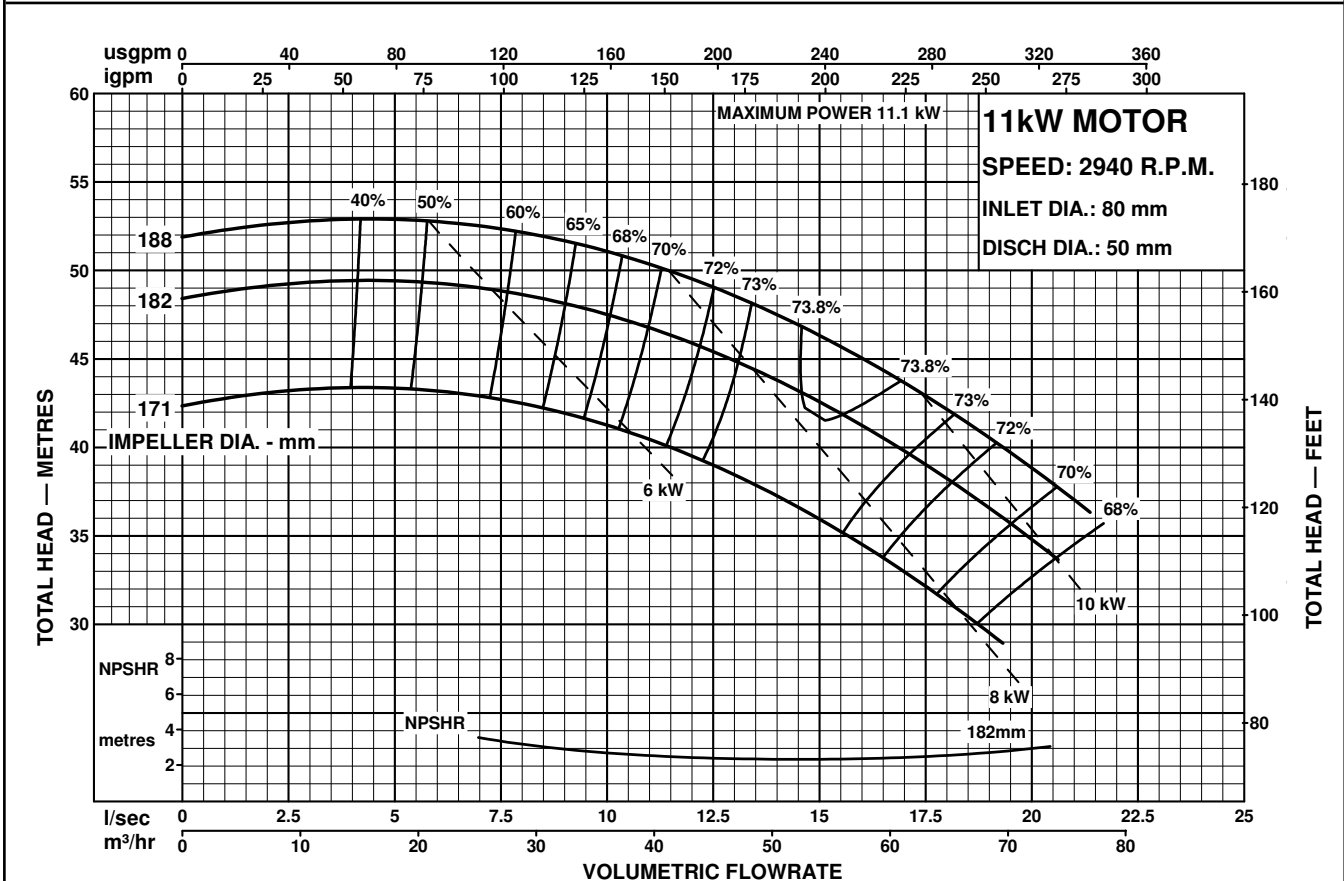

Performance to AS2417 Grade 2 for clean, cold water only.





# PENTAIR STARLINE

MOTORPUMPS

50Hz PERFORMANCE

MODEL  
**80x50-250**

CENTRIFUGAL PUMP PERFORMANCE DATA

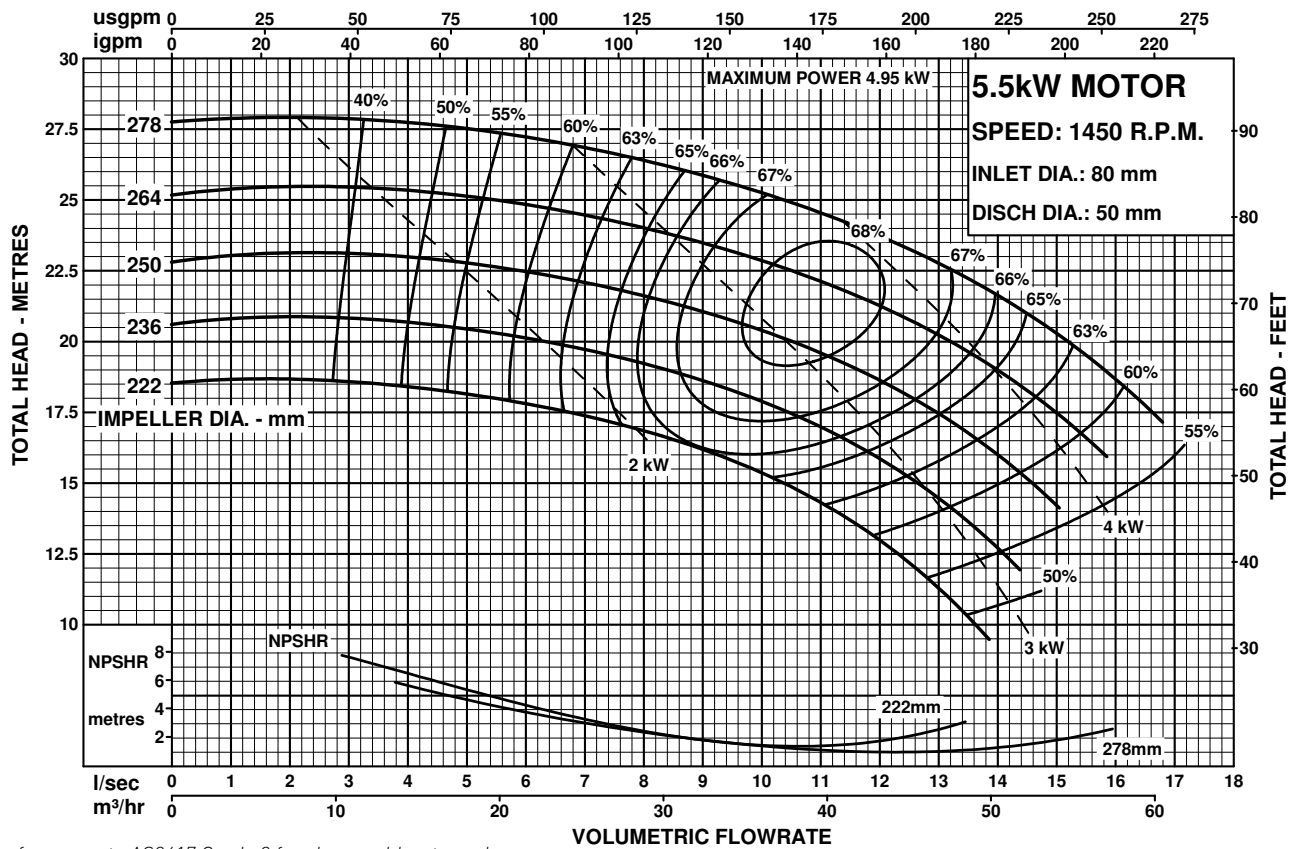

Performance to AS2417 Grade 2 for clean, cold water only.

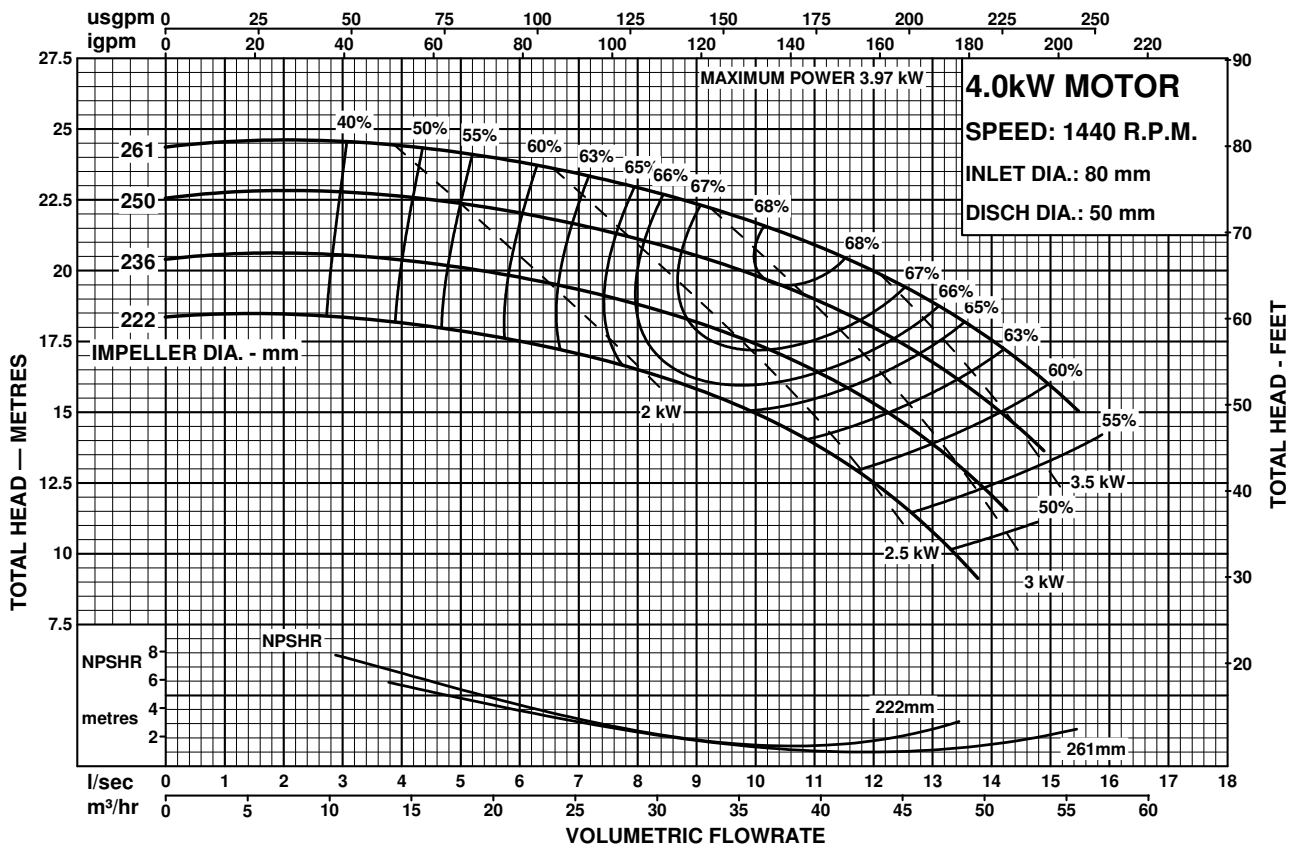

Performance to AS2417 Grade 2 for clean, cold water only.





# PENTAIR STARLINE

MOTORPUMPS  
50Hz PERFORMANCE

MODEL  
**80x50-250**

CENTRIFUGAL PUMP PERFORMANCE DATA

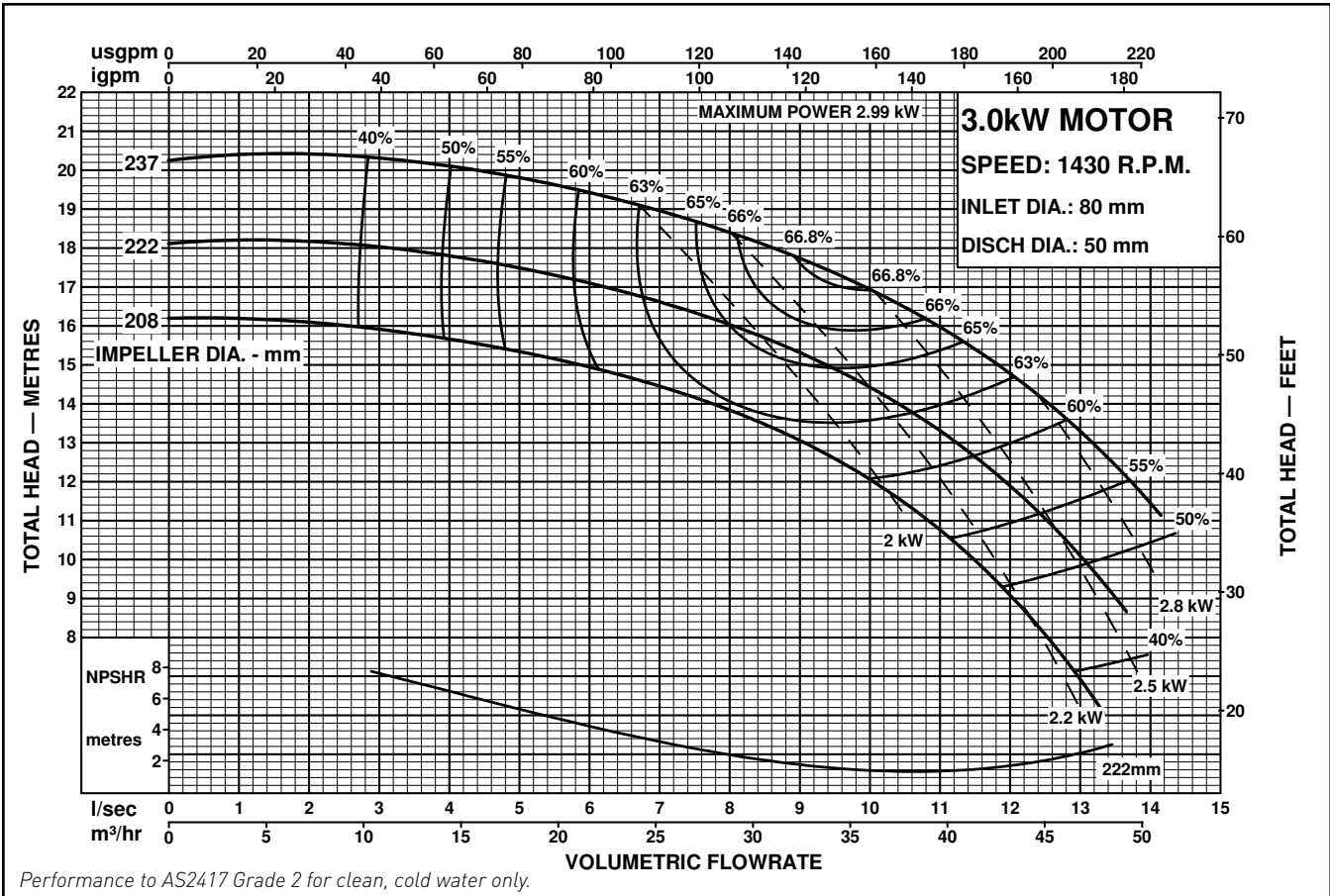

Performance to AS2417 Grade 2 for clean, cold water only.



# PENTAIR STARLINE

MOTORPUMPS

50Hz PERFORMANCE

MODEL

# 80x50-250

CENTRIFUGAL PUMP PERFORMANCE DATA

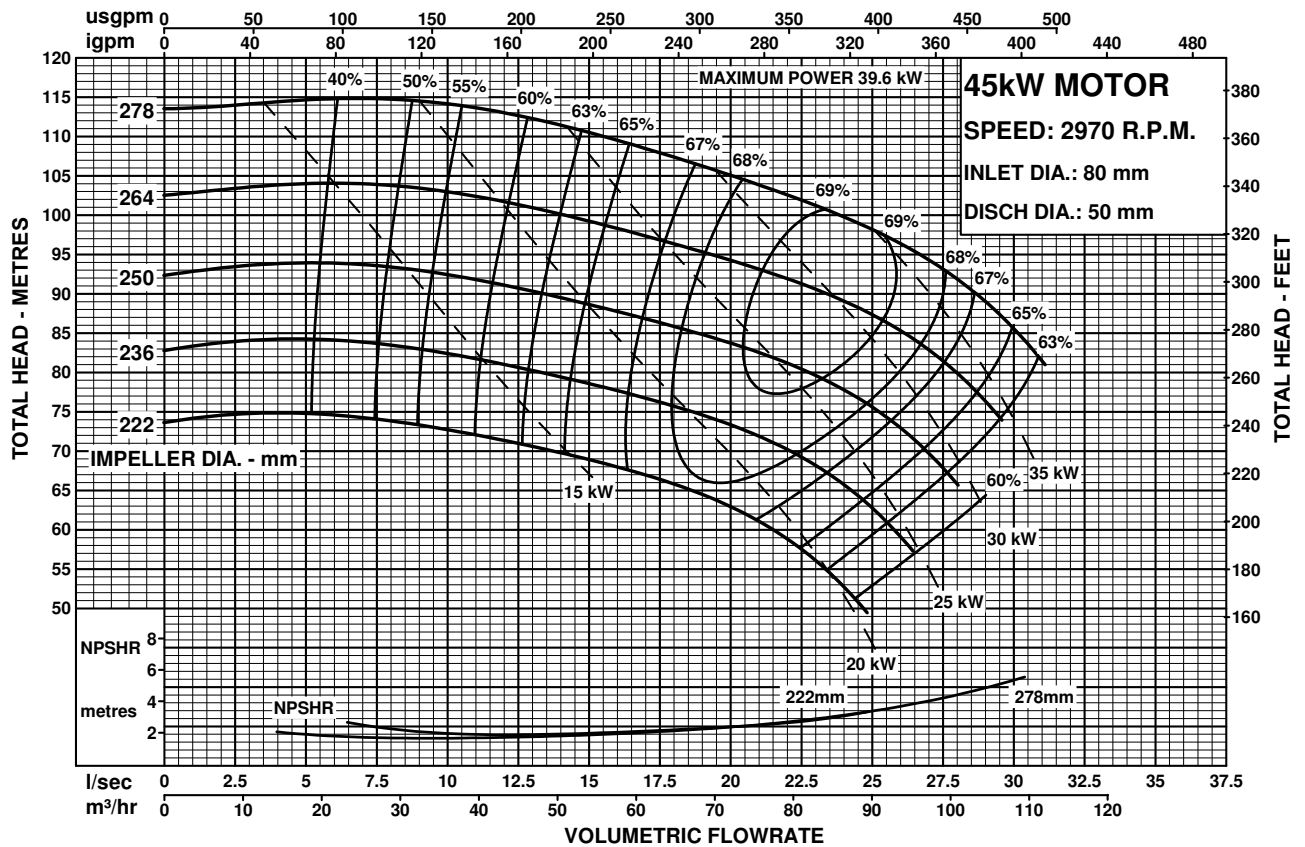

Performance to AS2417 Grade 2 for clean, cold water only.

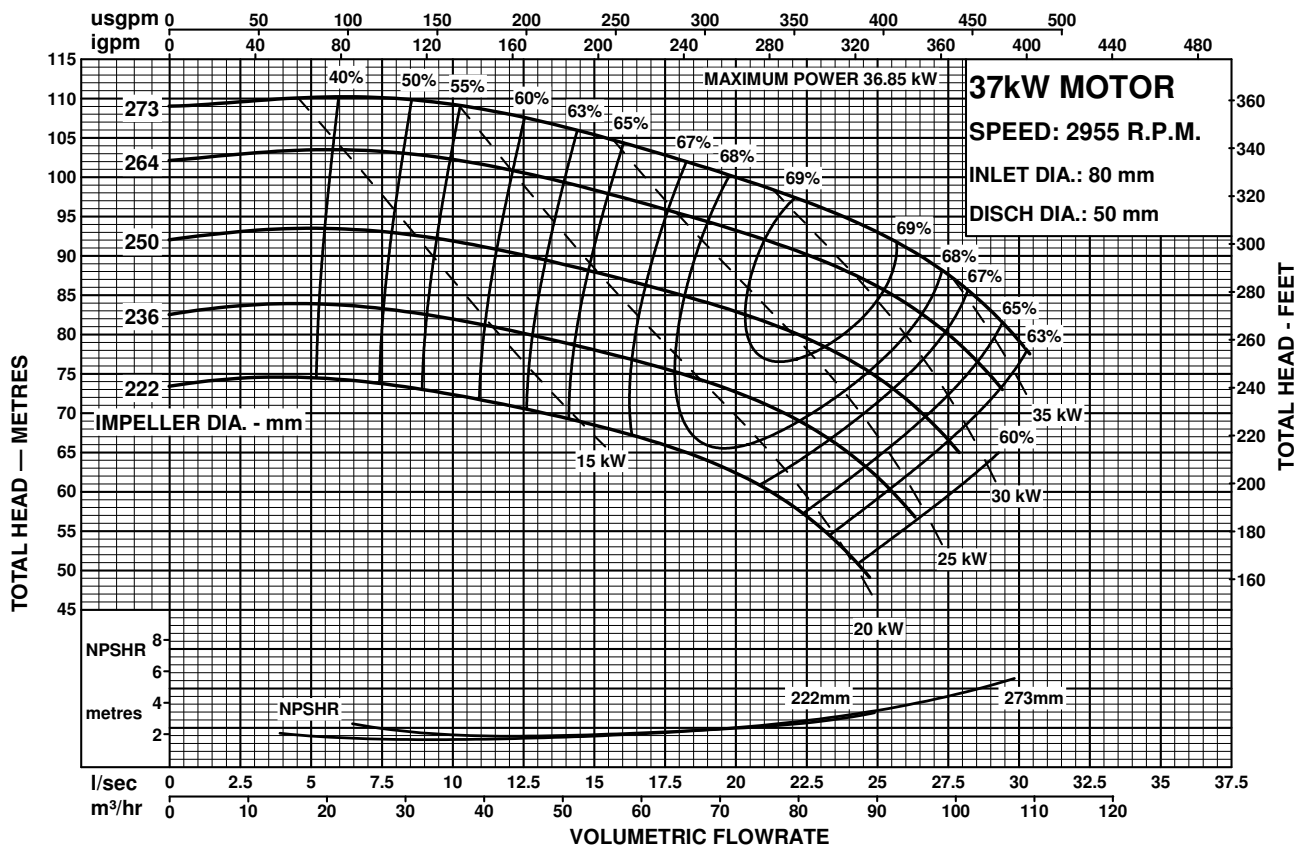

Performance to AS2417 Grade 2 for clean, cold water only.





# PENTAIR STARLINE

MOTORPUMPS  
50Hz PERFORMANCE

MODEL  
**80x50-250**

CENTRIFUGAL PUMP PERFORMANCE DATA

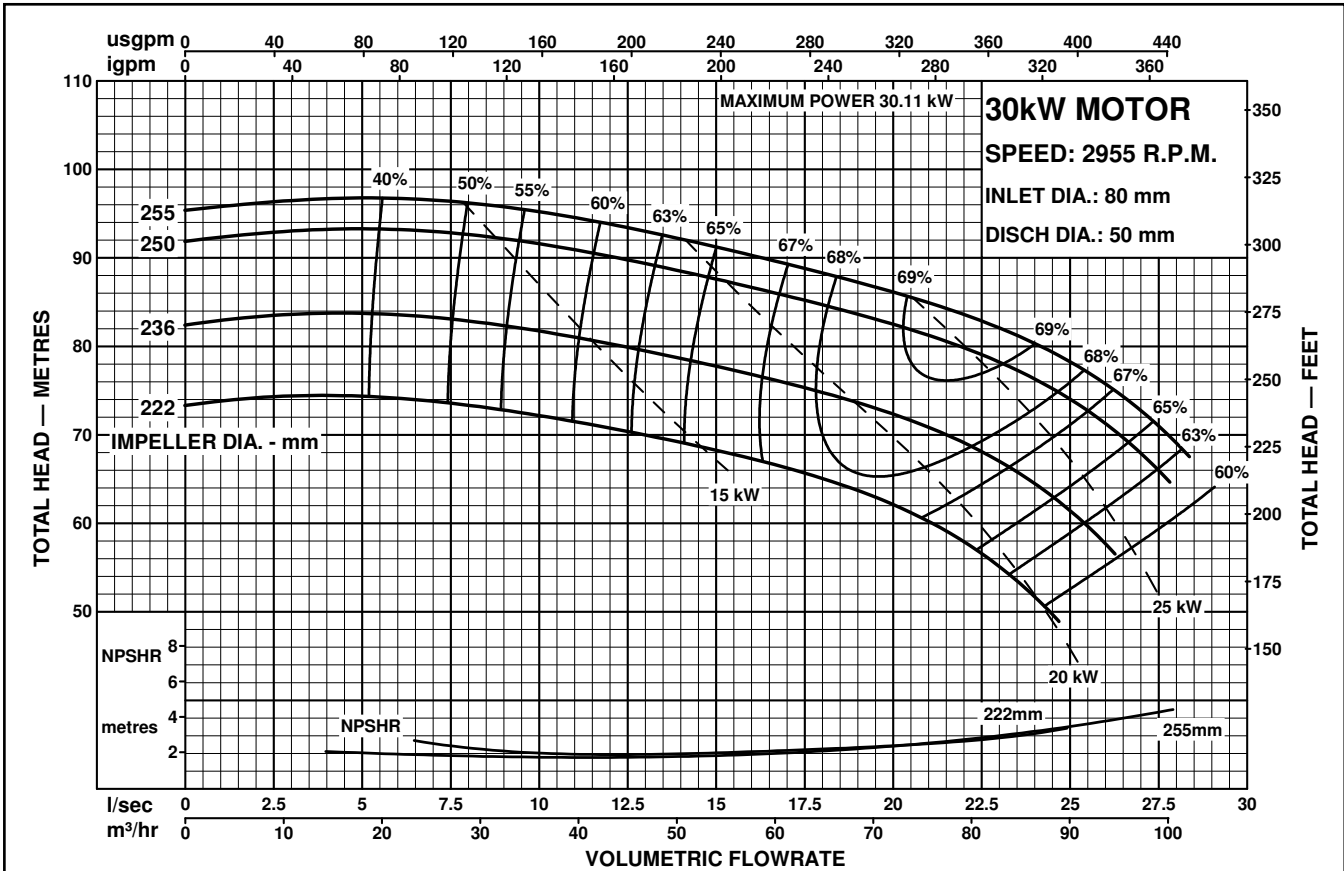

Performance to AS2417 Grade 2 for clean, cold water only.

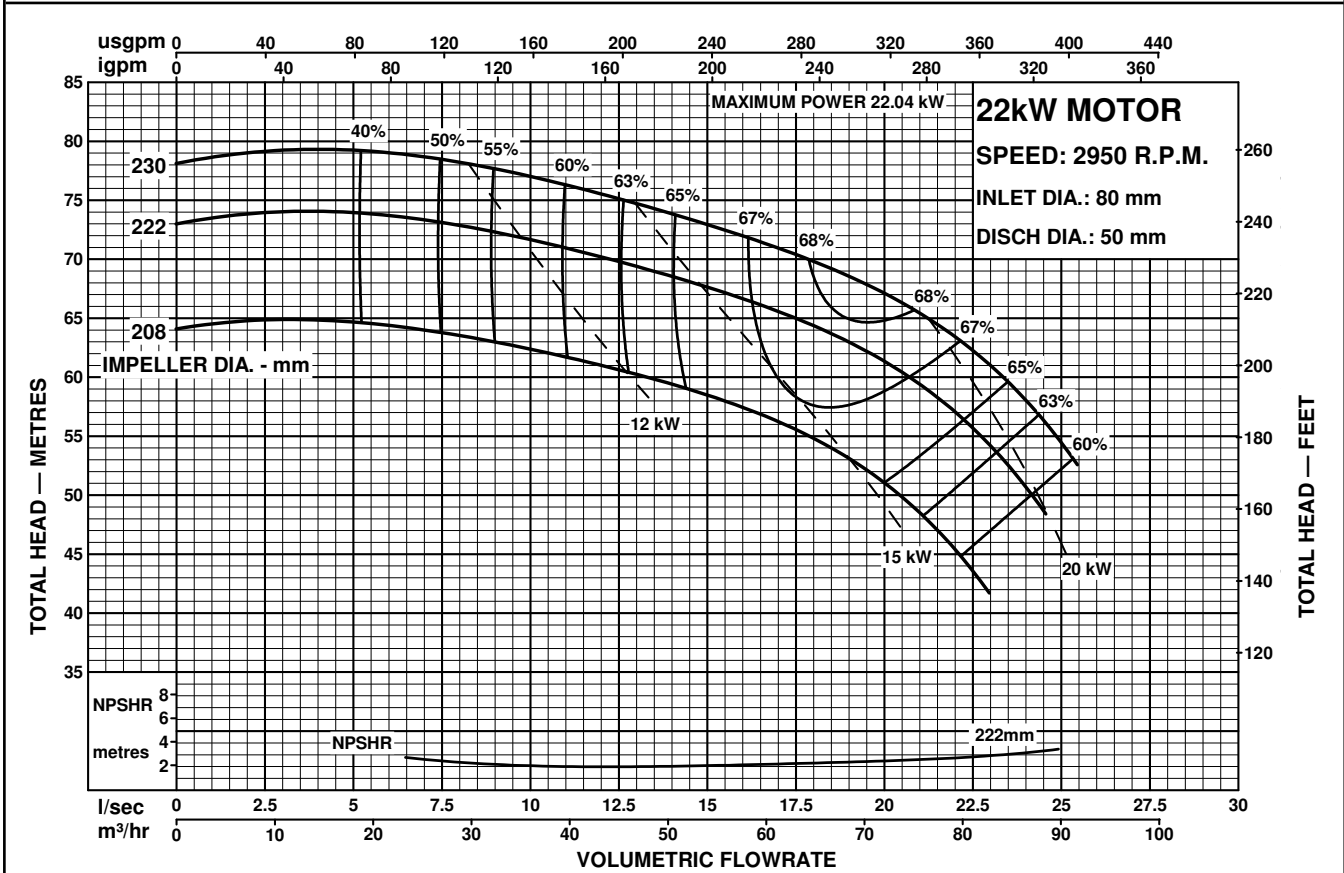

Performance to AS2417 Grade 2 for clean, cold water only.





# PENTAIR STARLINE

MOTORPUMPS

50Hz PERFORMANCE

MODEL

# 80x50-315

CENTRIFUGAL PUMP PERFORMANCE DATA

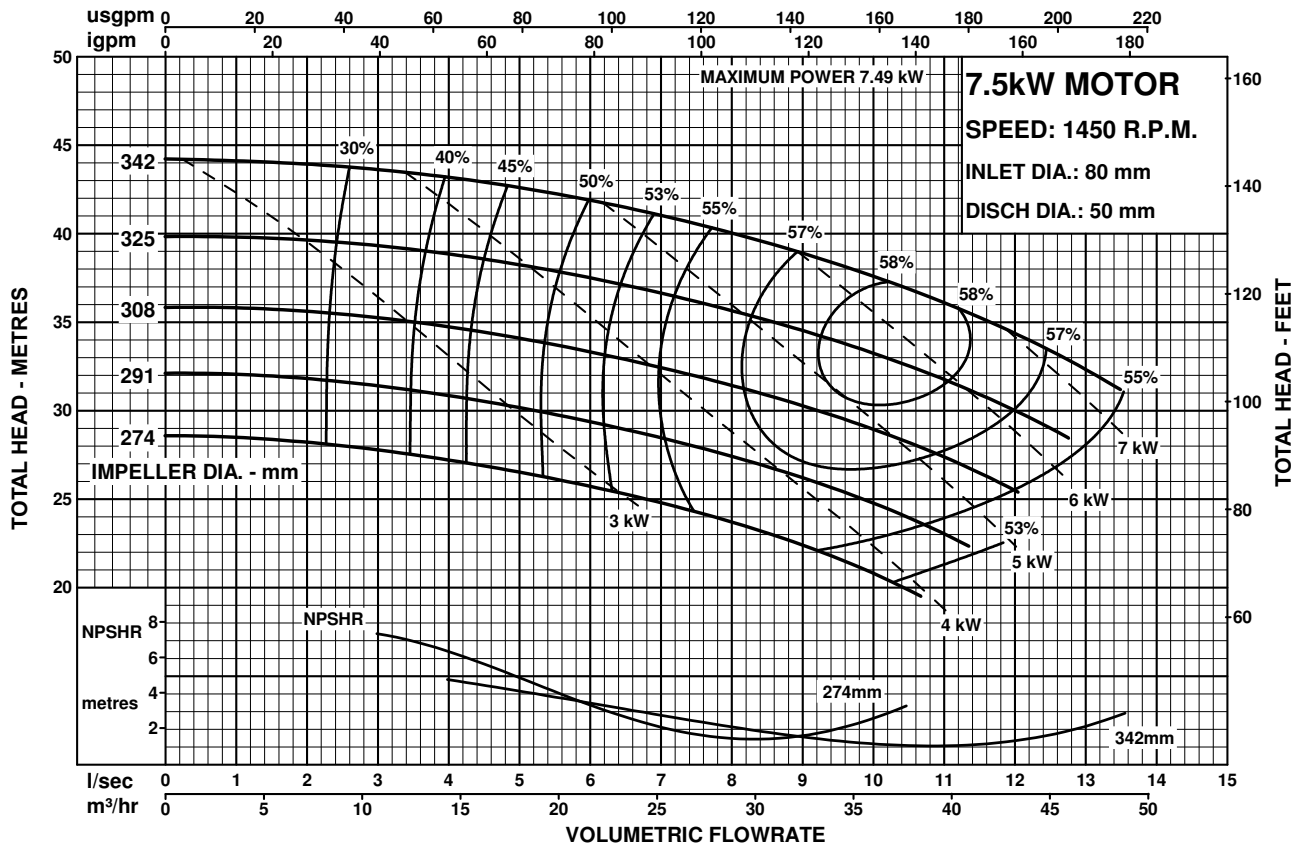

Performance to AS2417 Grade 2 for clean, cold water only.

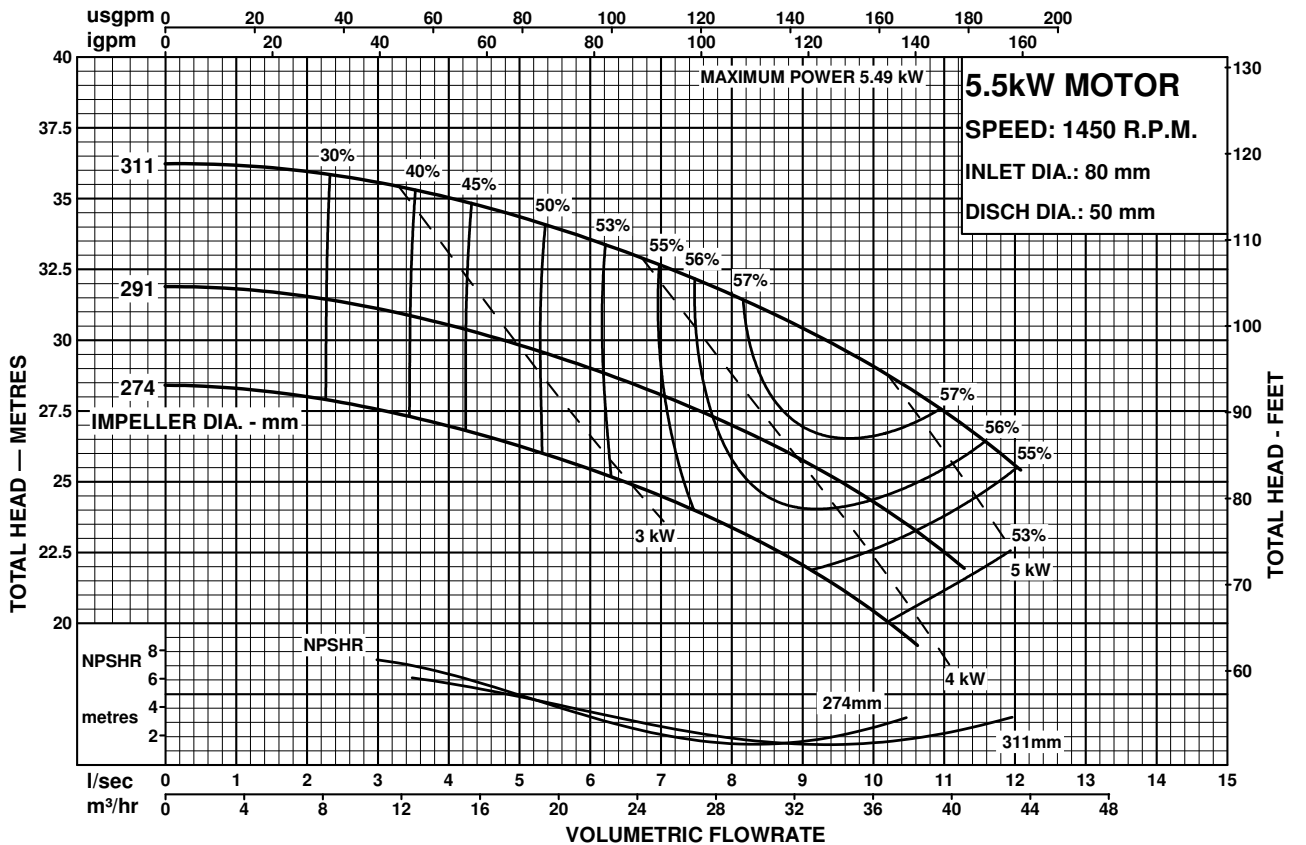

Performance to AS2417 Grade 2 for clean, cold water only.





# PENTAIR STARLINE

MOTORPUMPS  
50Hz PERFORMANCE

MODEL  
**80x50-315**

CENTRIFUGAL PUMP PERFORMANCE DATA

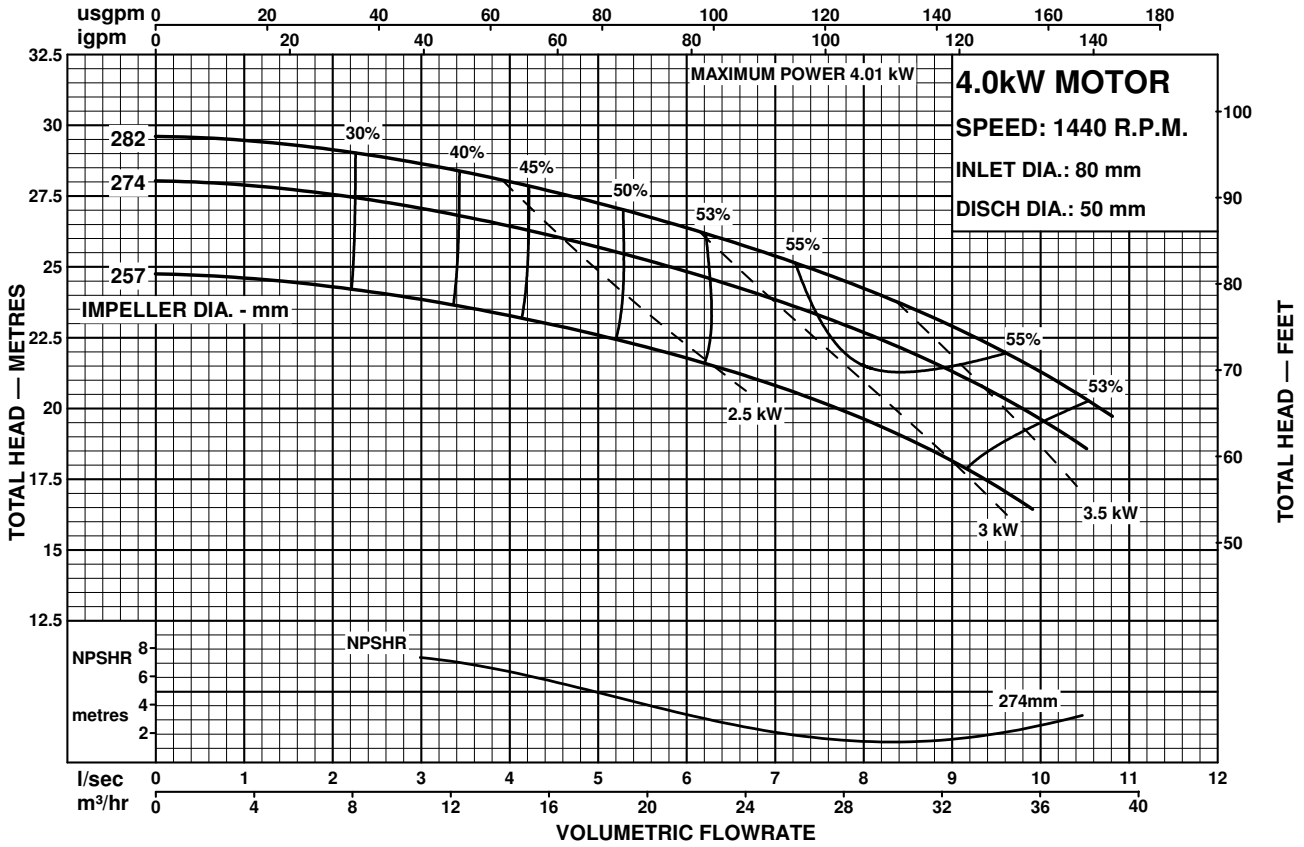

Performance to AS2417 Grade 2 for clean, cold water only.





# PENTAIR STARLINE

MOTORPUMPS

50Hz PERFORMANCE

## MODEL 80x50-315

### CENTRIFUGAL PUMP PERFORMANCE DATA

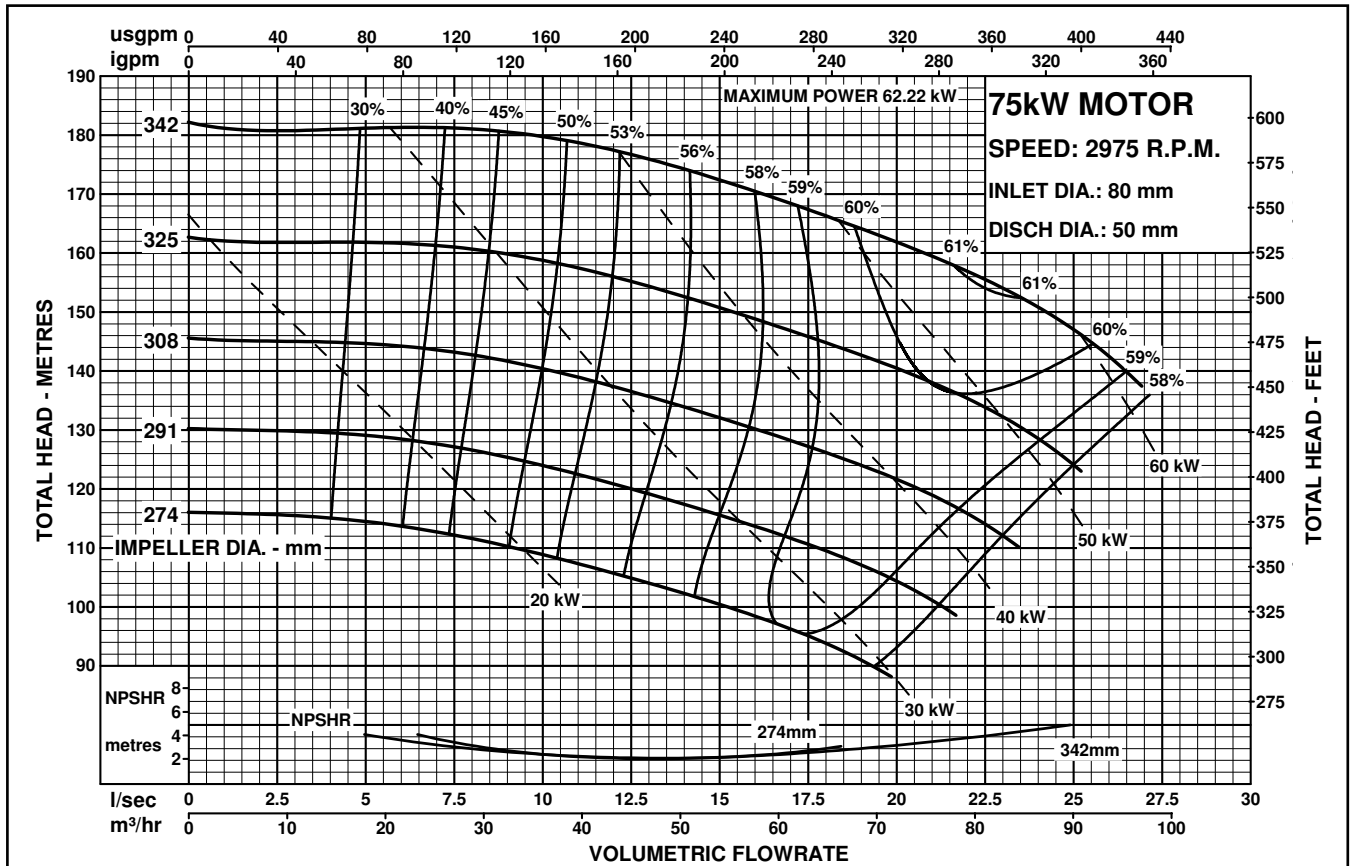

Performance to AS2417 Grade 2 for clean, cold water only.

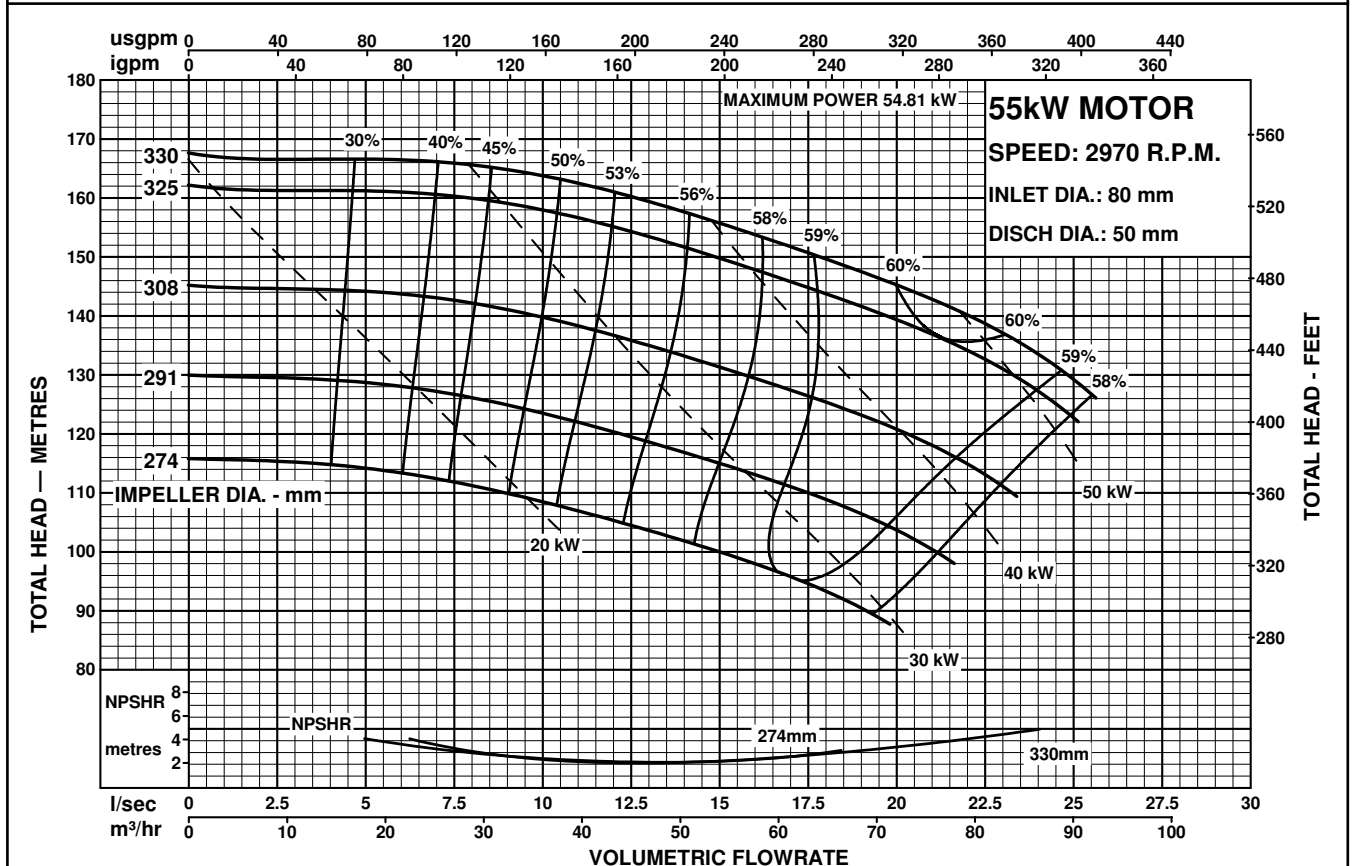

Performance to AS2417 Grade 2 for clean, cold water only.





# PENTAIR STARLINE

MOTORPUMPS  
50Hz PERFORMANCE

MODEL  
**80x50-315**

CENTRIFUGAL PUMP PERFORMANCE DATA

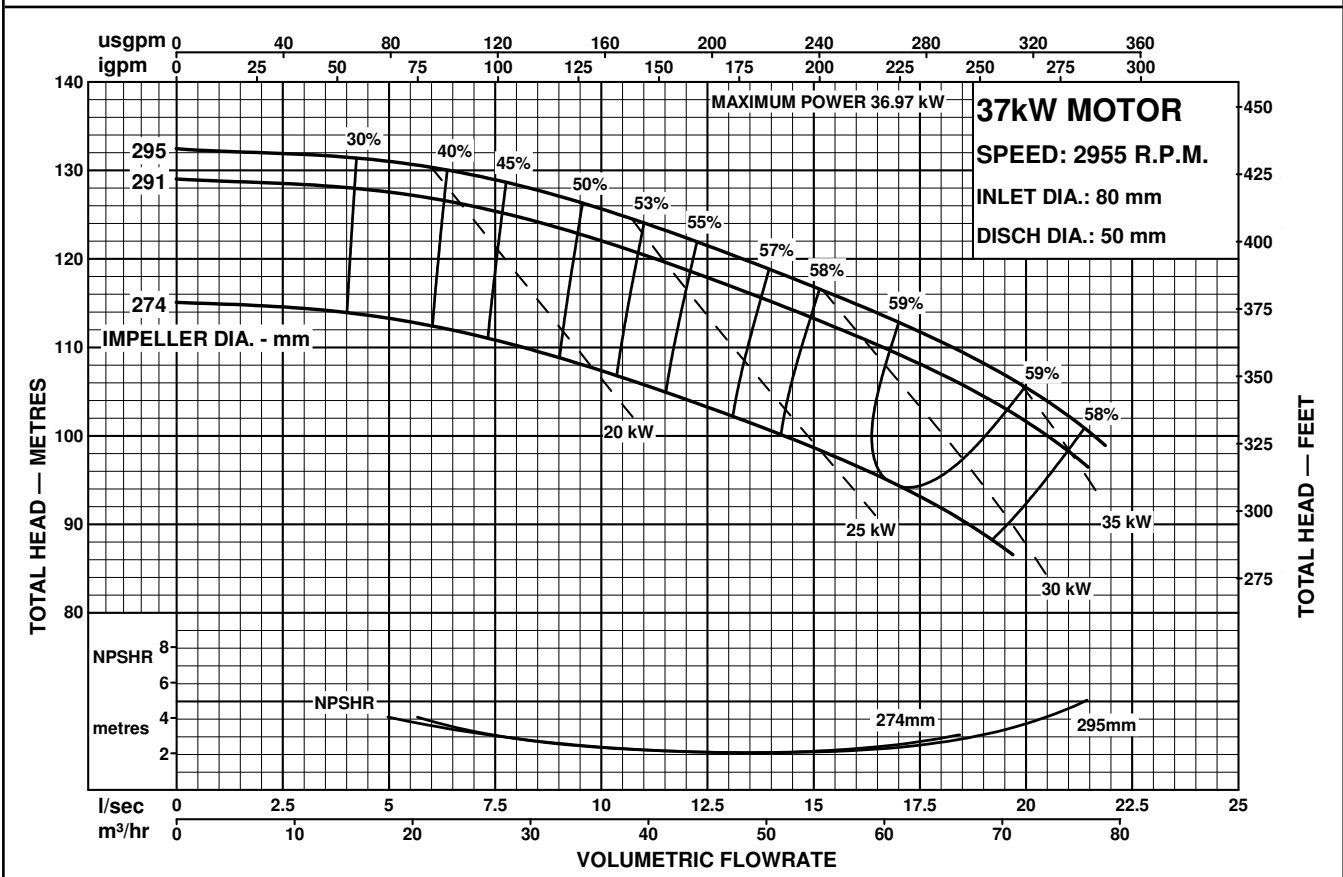
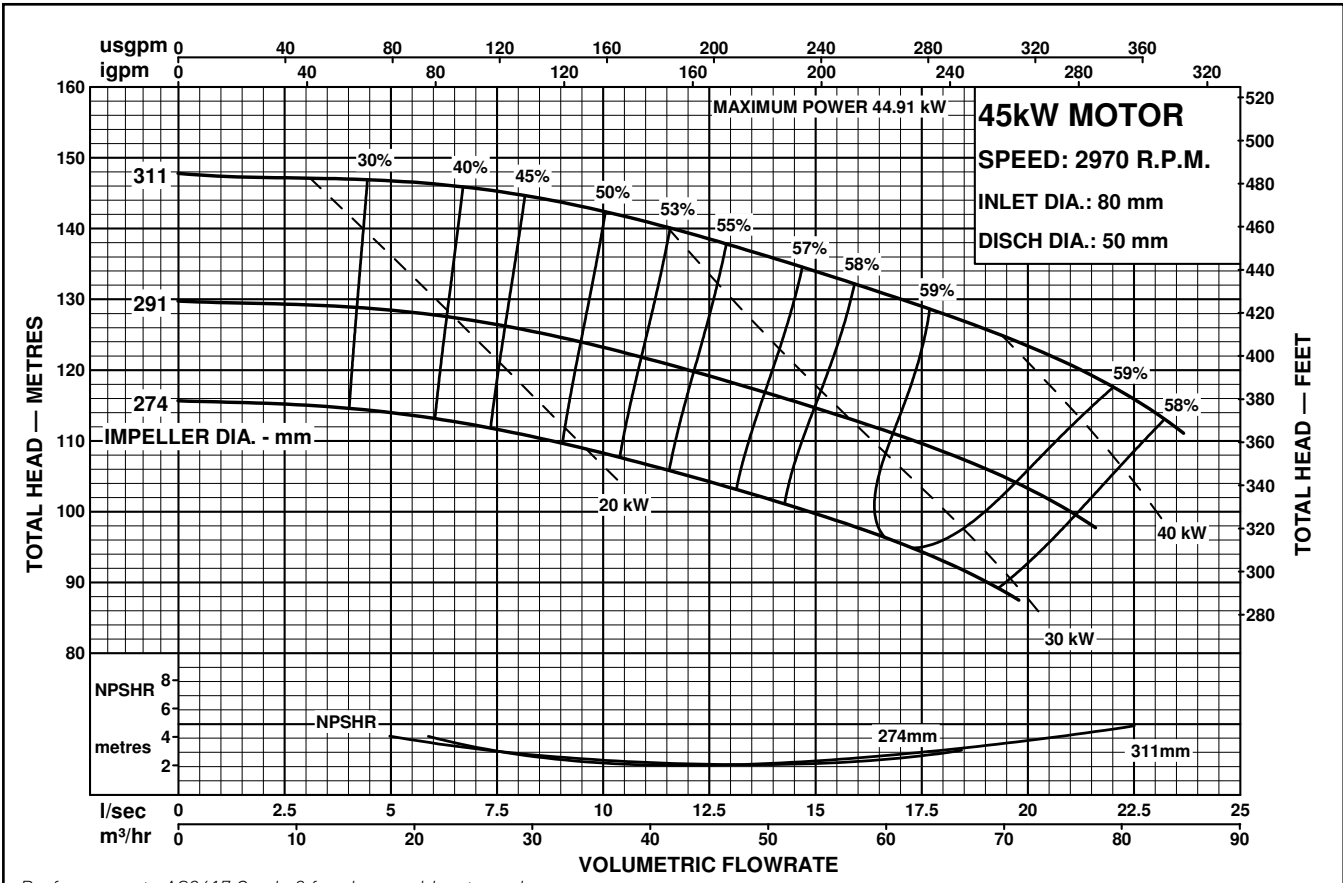



# PENTAIR STARLINE

MOTORPUMPS  
50Hz PERFORMANCE

MODEL  
**80x50-315**

CENTRIFUGAL PUMP PERFORMANCE DATA

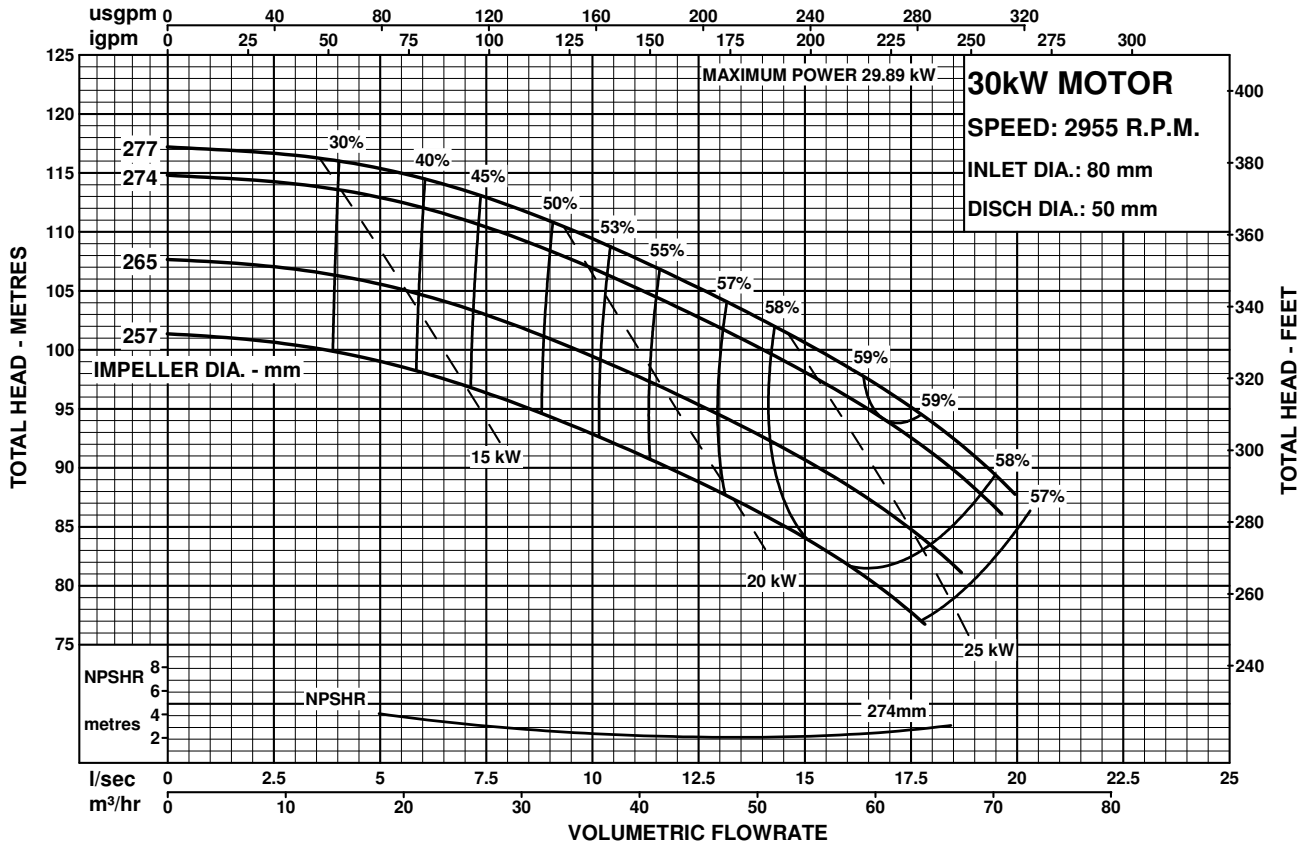

Performance to AS2417 Grade 2 for clean, cold water only.





# PENTAIR STARLINE

MOTORPUMPS  
50Hz PERFORMANCE

MODEL  
**100x80-160**

CENTRIFUGAL PUMP PERFORMANCE DATA

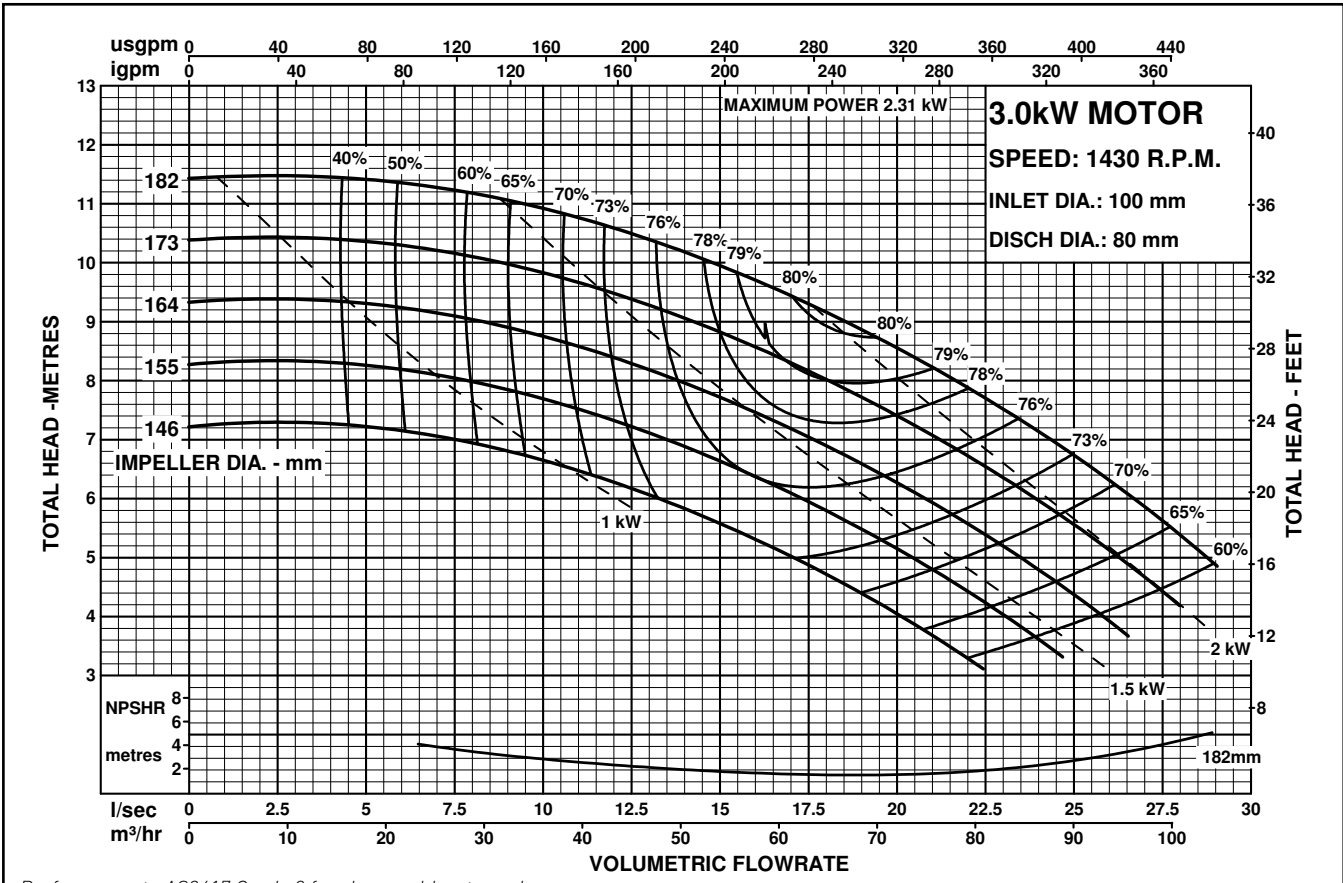

Performance to AS2417 Grade 2 for clean, cold water only.

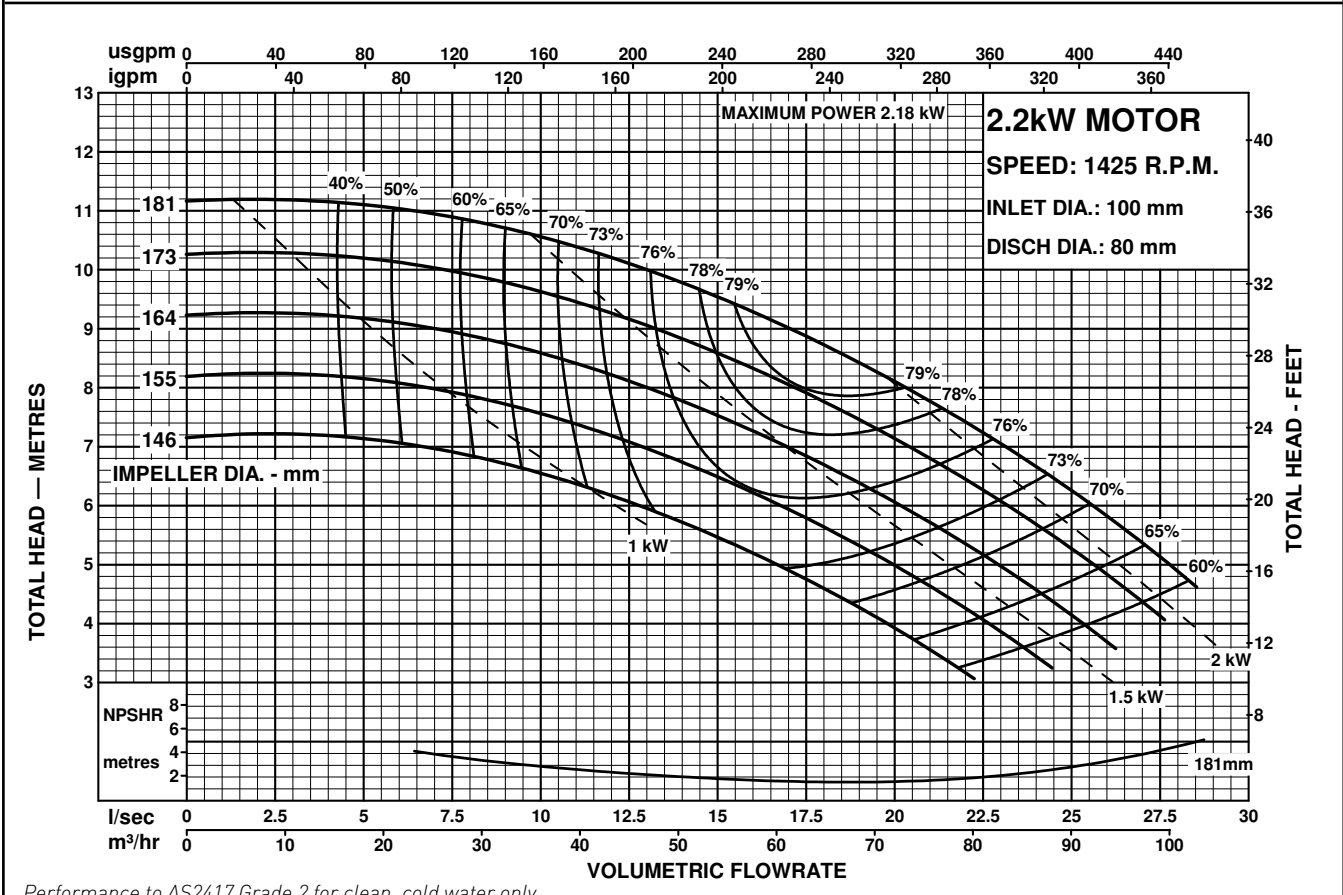

Performance to AS2417 Grade 2 for clean, cold water only.





# PENTAIR STARLINE

MOTORPUMPS

50Hz PERFORMANCE

MODEL  
**100x80-160**

## CENTRIFUGAL PUMP PERFORMANCE DATA

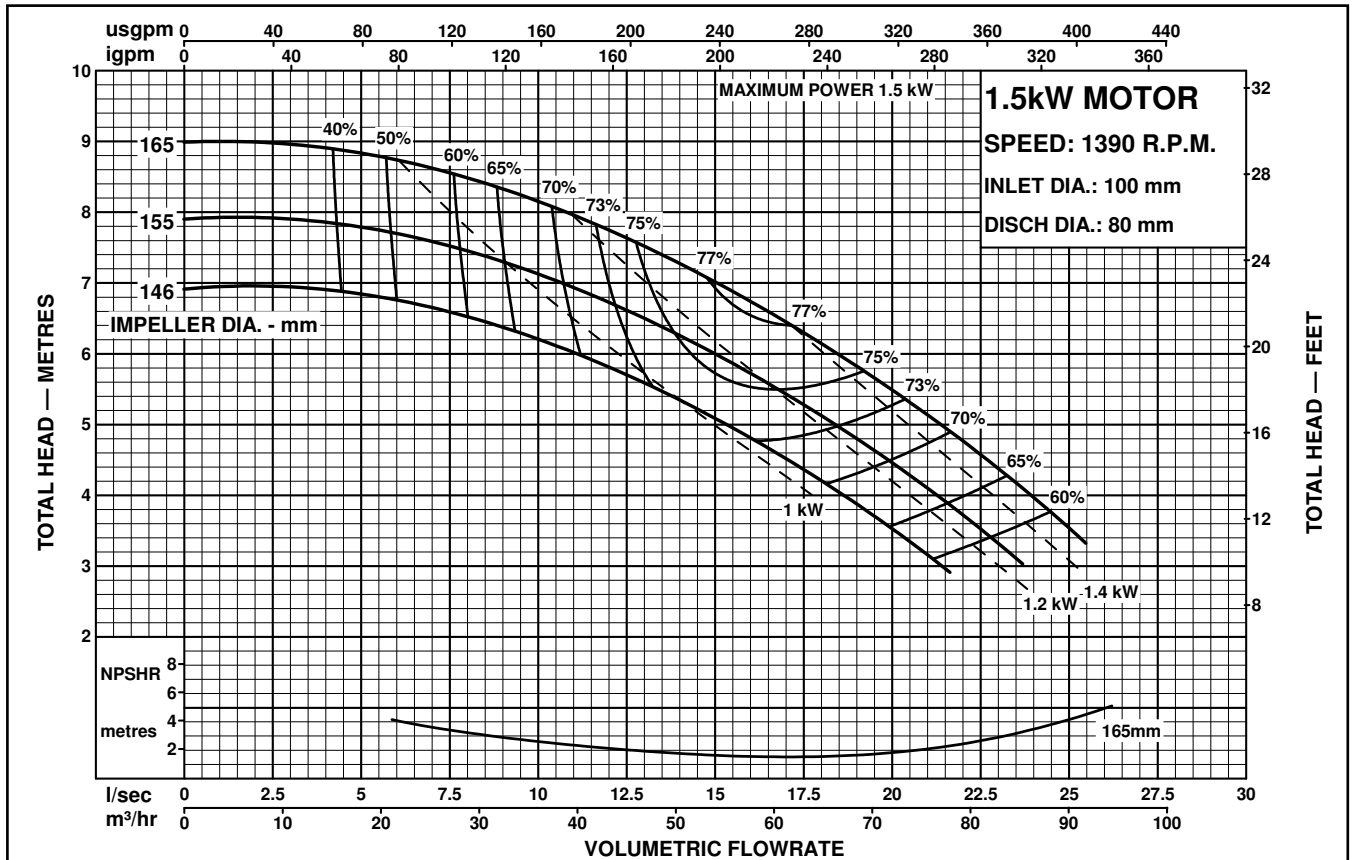

Performance to AS2417 Grade 2 for clean, cold water only.

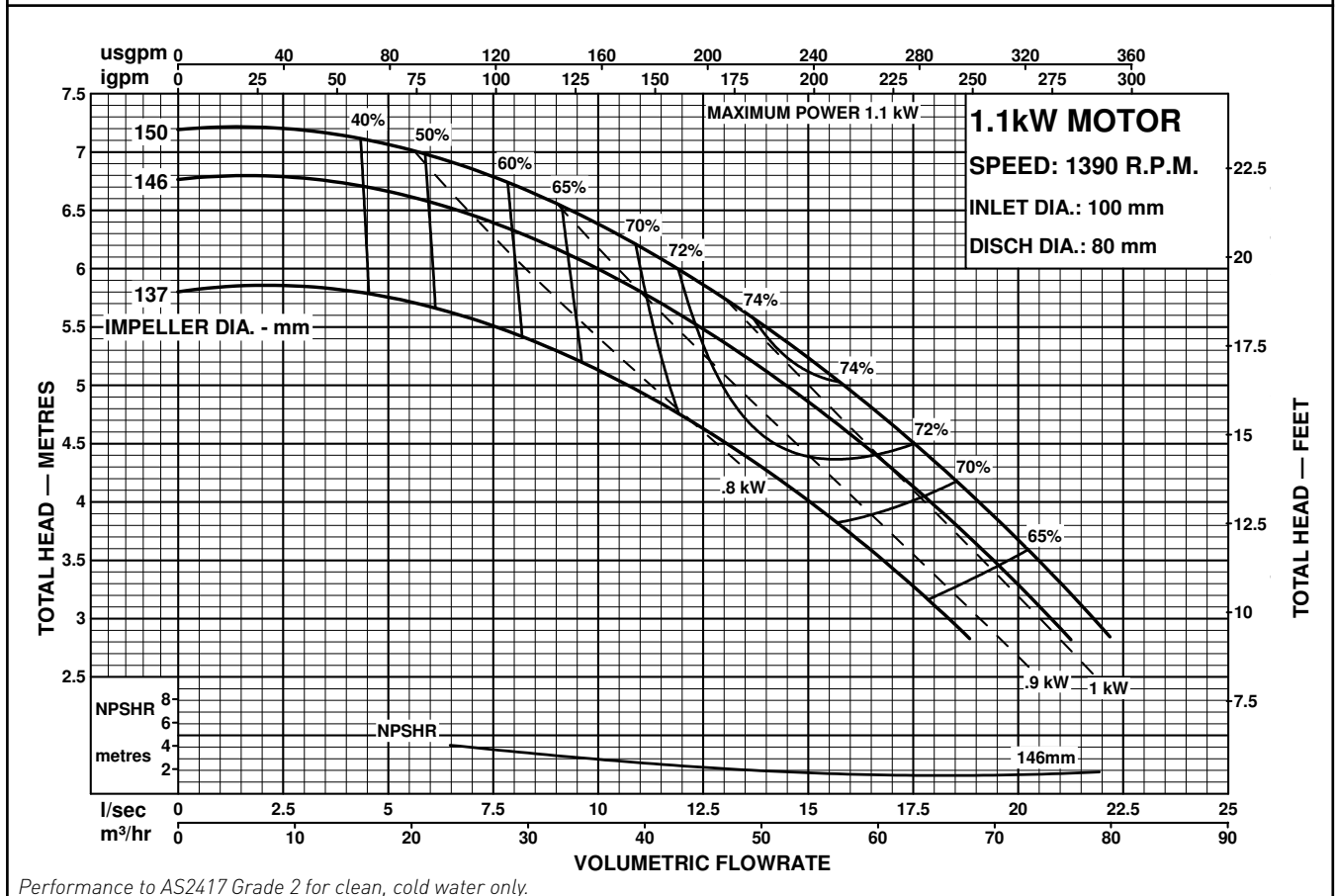

Performance to AS2417 Grade 2 for clean, cold water only.





# PENTAIR STARLINE

MOTORPUMPS  
50Hz PERFORMANCE

MODEL  
**100x80-160**

CENTRIFUGAL PUMP PERFORMANCE DATA

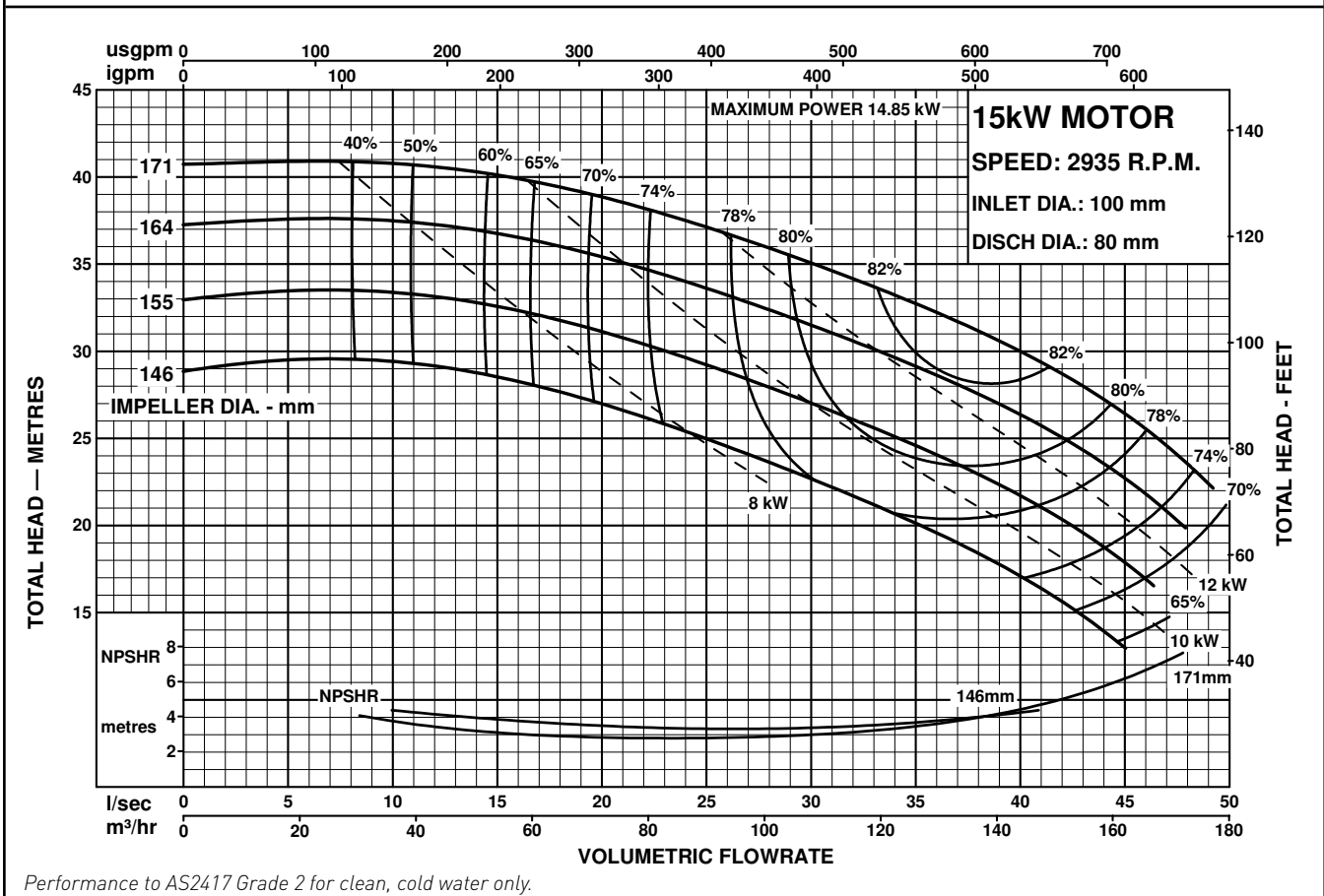
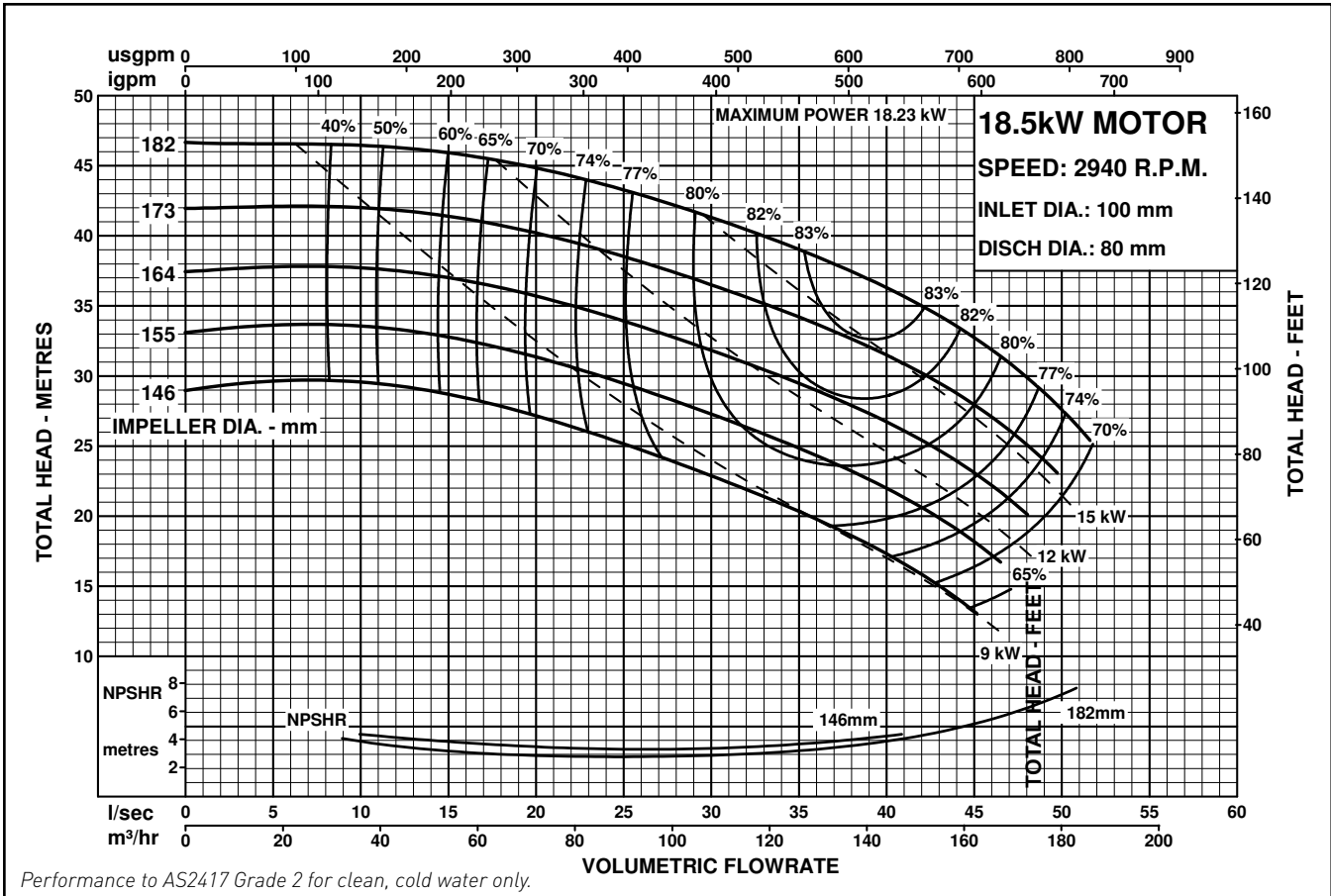



# PENTAIR STARLINE

MOTORPUMPS  
50Hz PERFORMANCE

MODEL  
**100x80-160**

CENTRIFUGAL PUMP PERFORMANCE DATA

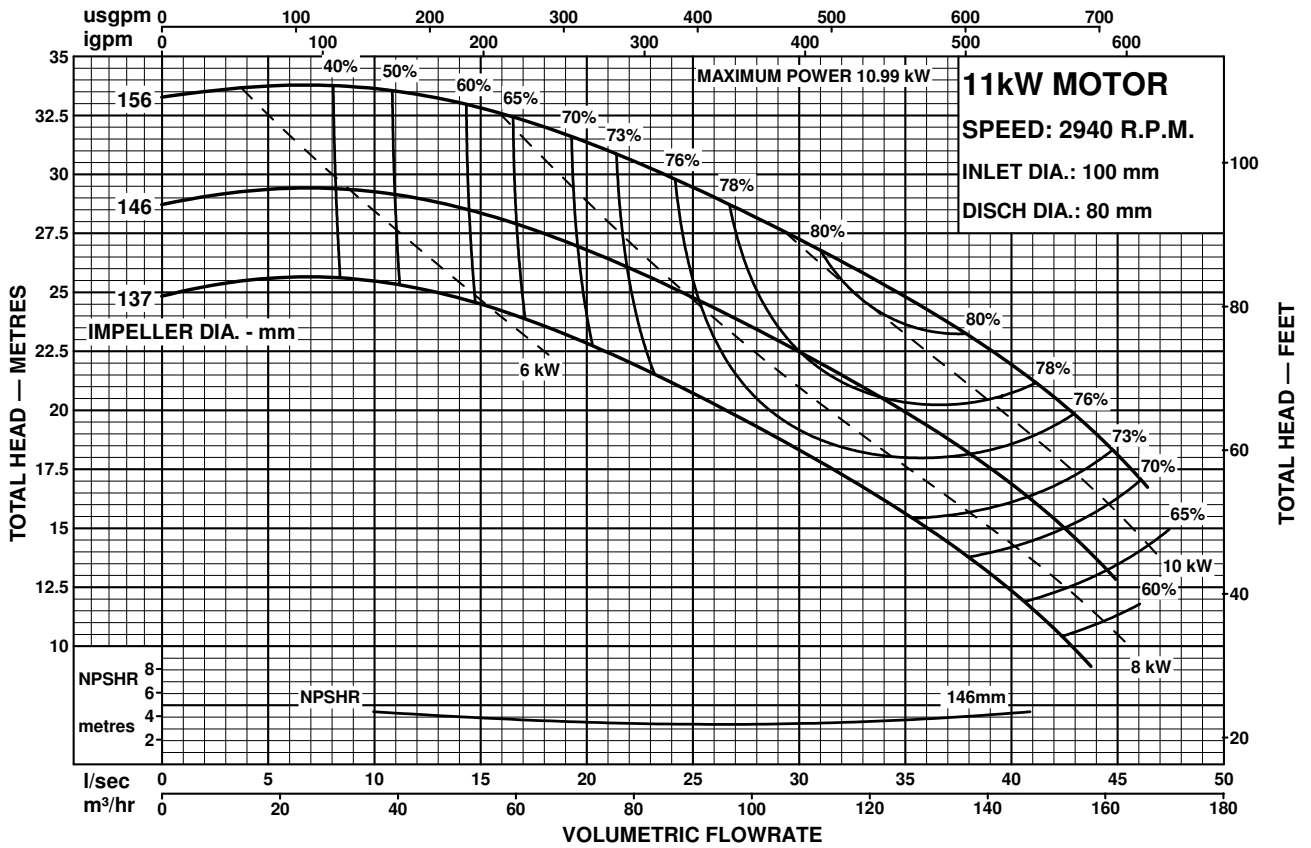

Performance to AS2417 Grade 2 for clean, cold water only.





# PENTAIR STARLINE

MOTORPUMPS  
50Hz PERFORMANCE

MODEL  
**100x65-200**

CENTRIFUGAL PUMP PERFORMANCE DATA

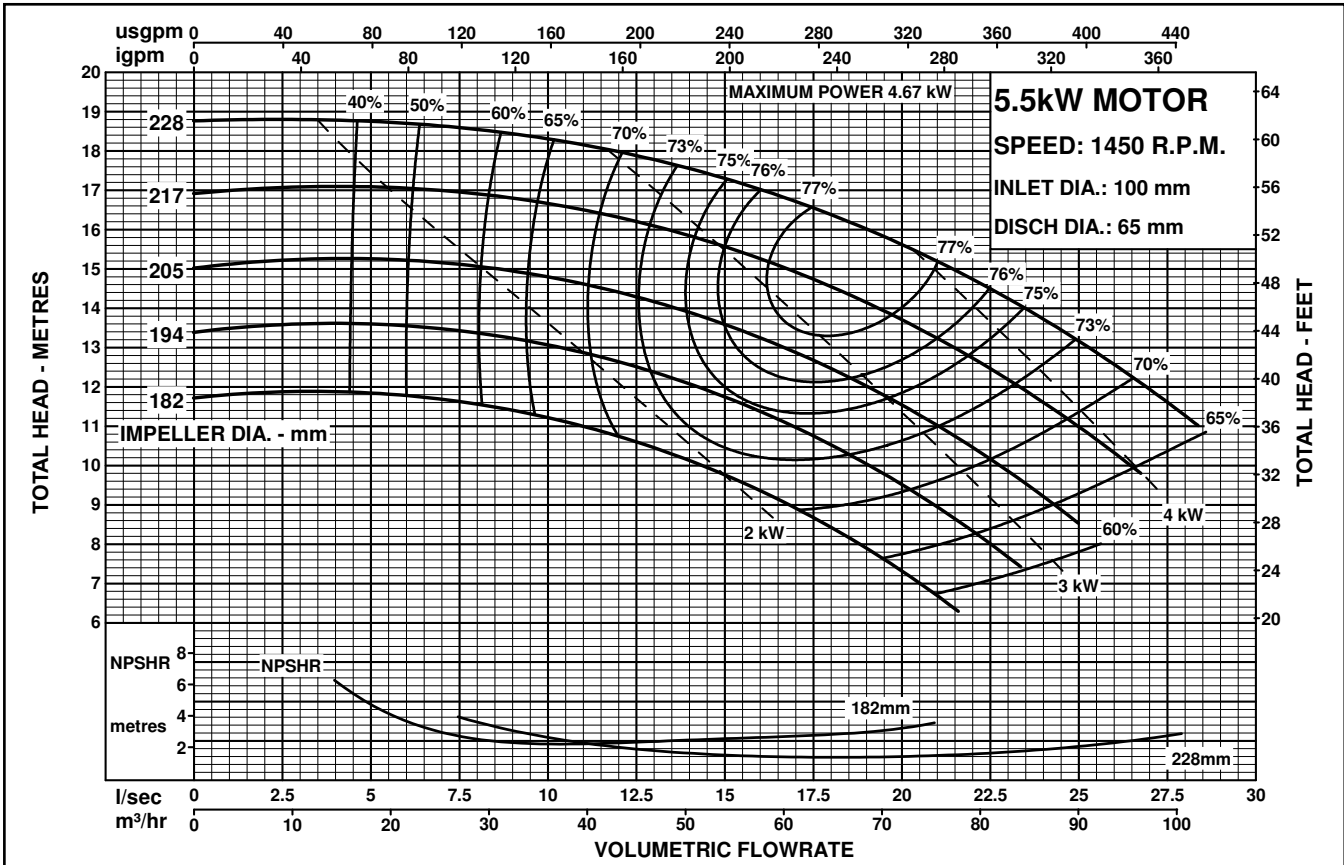

Performance to AS2417 Grade 2 for clean, cold water only.

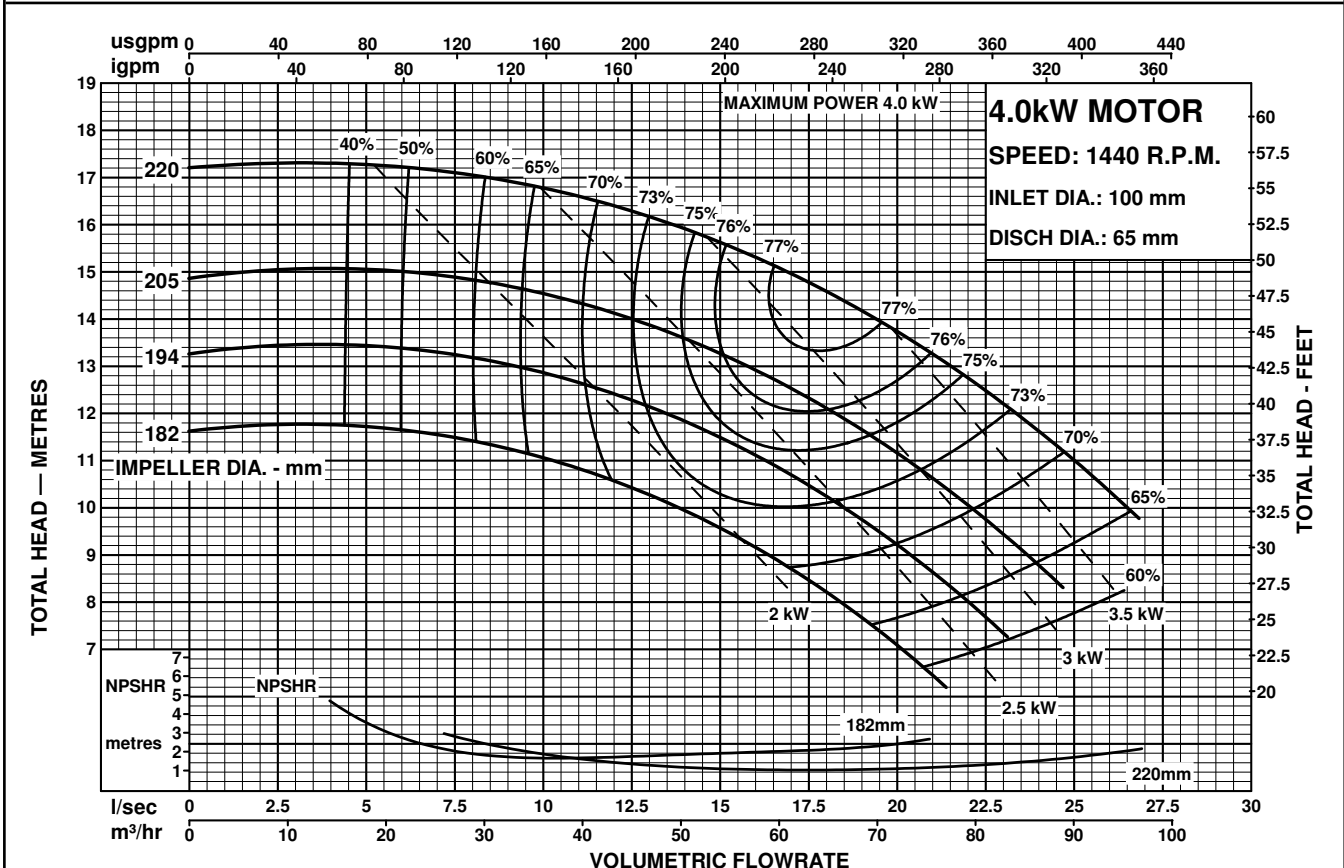

Performance to AS2417 Grade 2 for clean, cold water only.







# PENTAIR STARLINE

MOTORPUMPS

50Hz PERFORMANCE

MODEL  
**100x65-200**

CENTRIFUGAL PUMP PERFORMANCE DATA

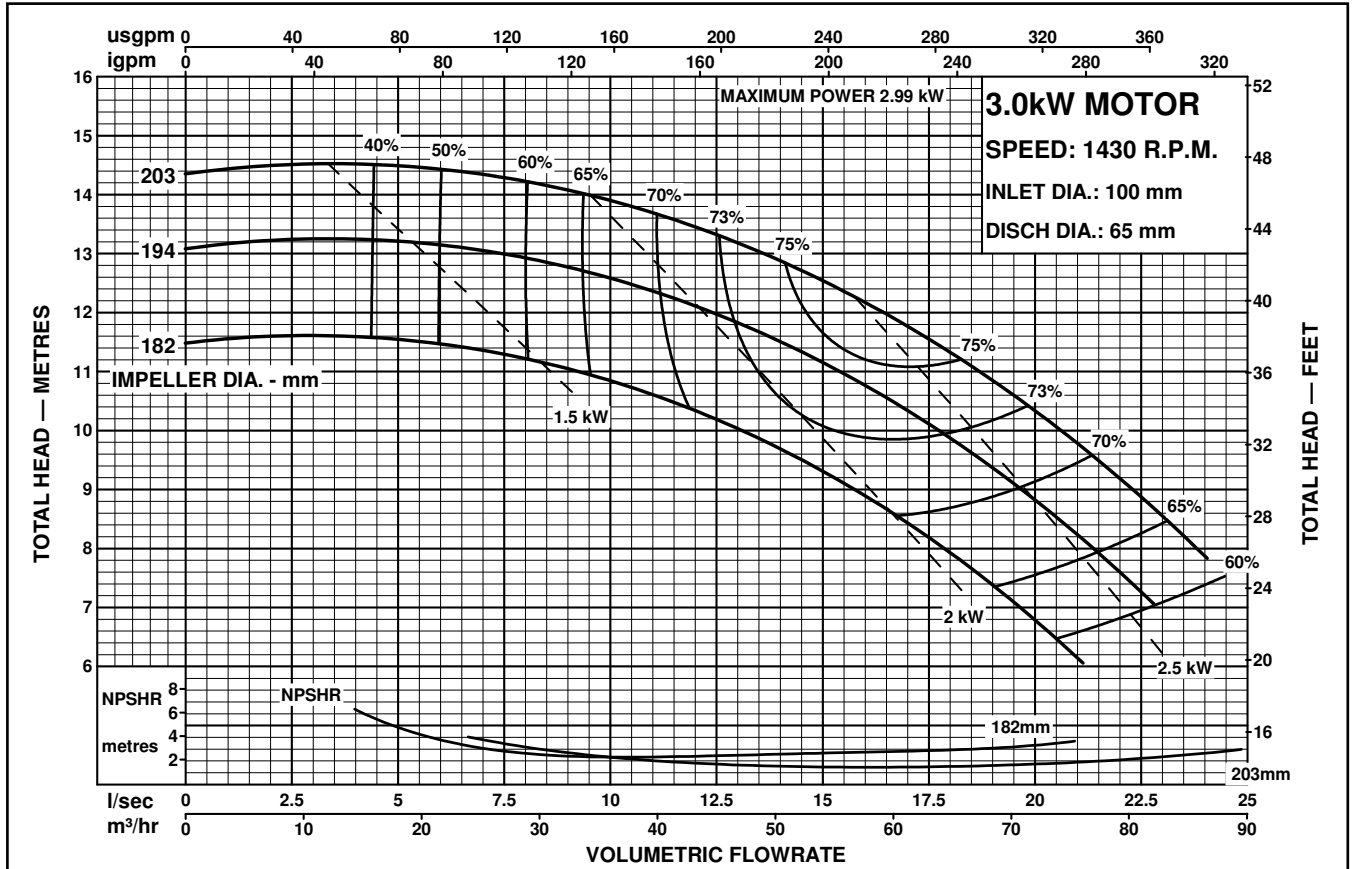

Performance to AS2417 Grade 2 for clean, cold water only.

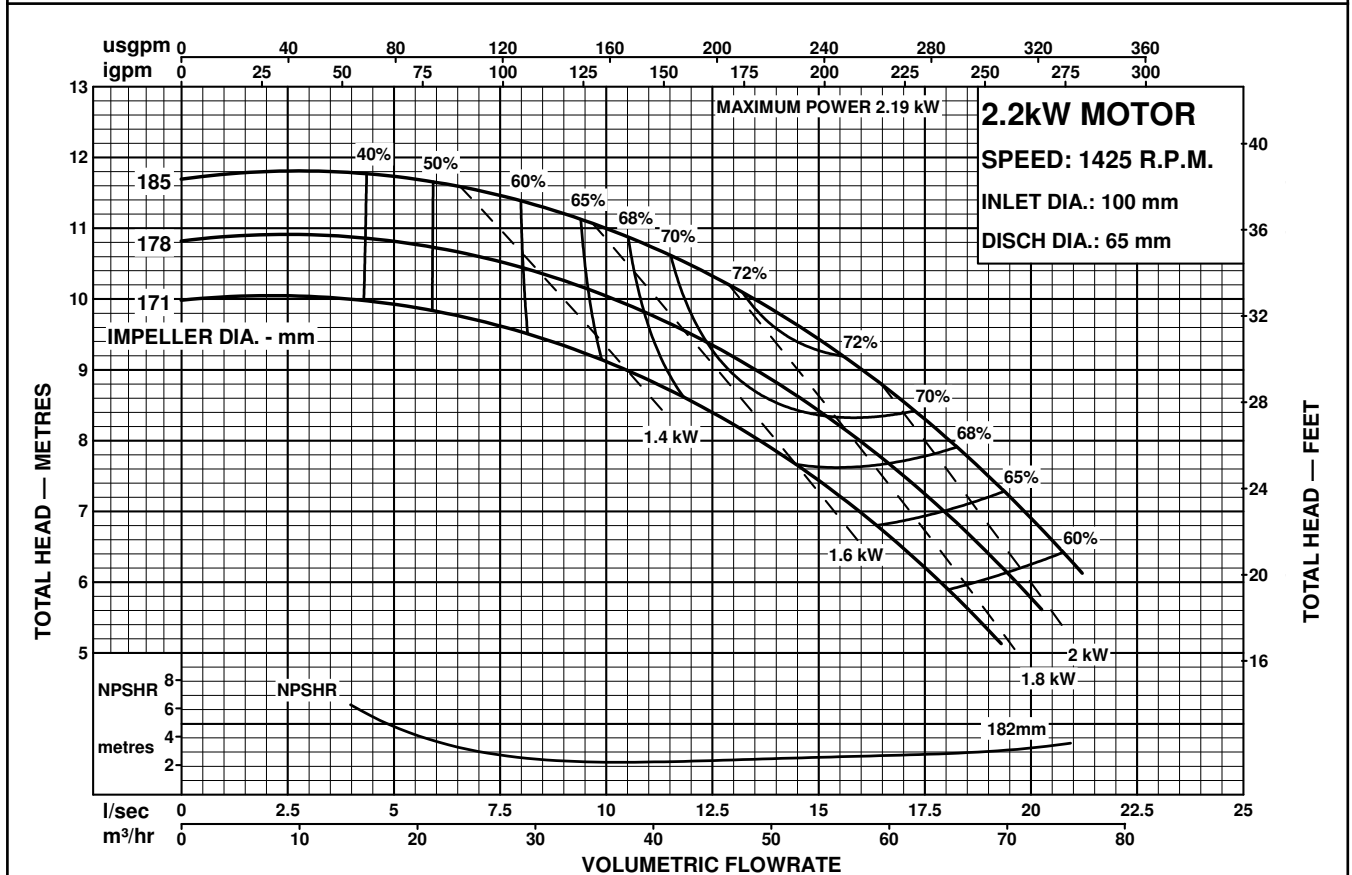

Performance to AS2417 Grade 2 for clean, cold water only.





# PENTAIR STARLINE

MOTORPUMPS  
50Hz PERFORMANCE

MODEL  
**100x65-200**

CENTRIFUGAL PUMP PERFORMANCE DATA

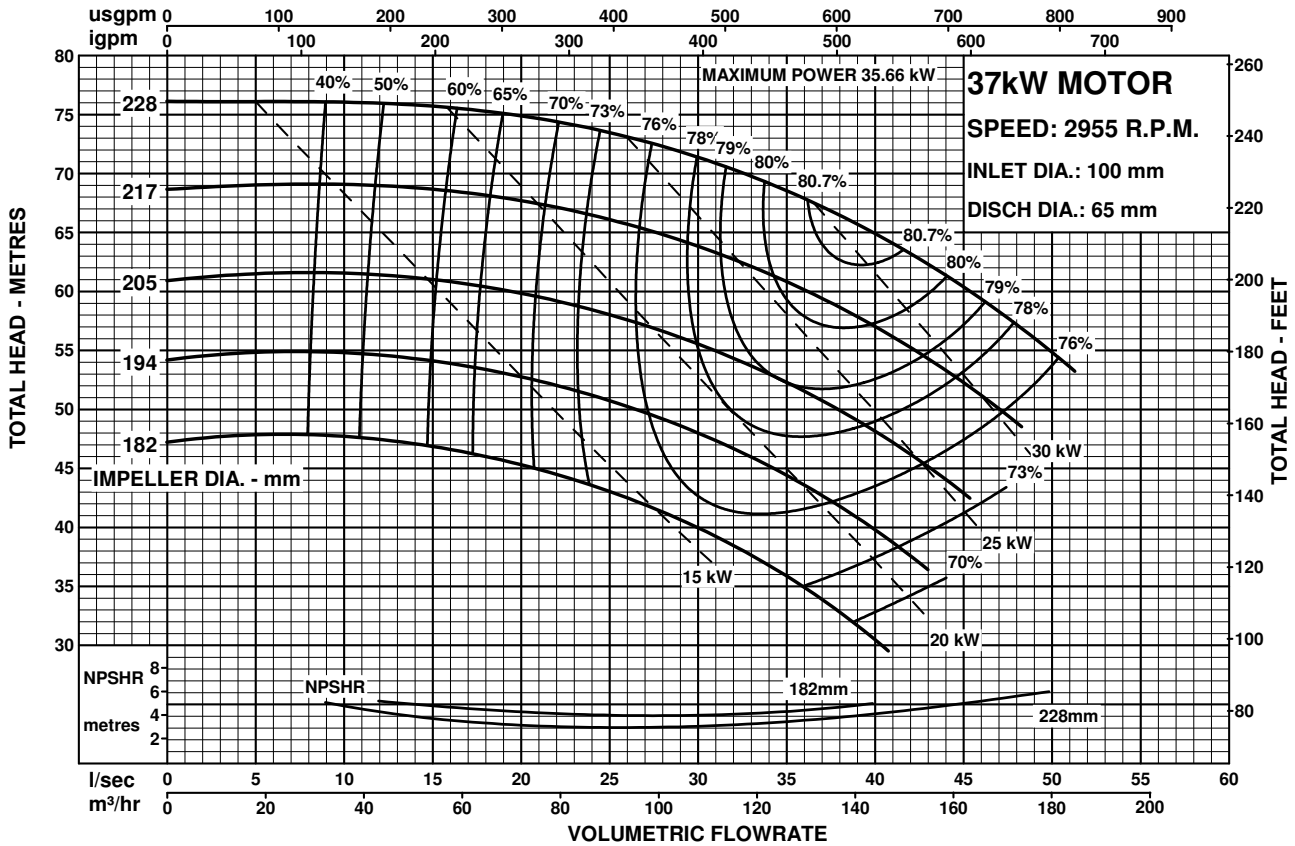

Performance to AS2417 Grade 2 for clean, cold water only.

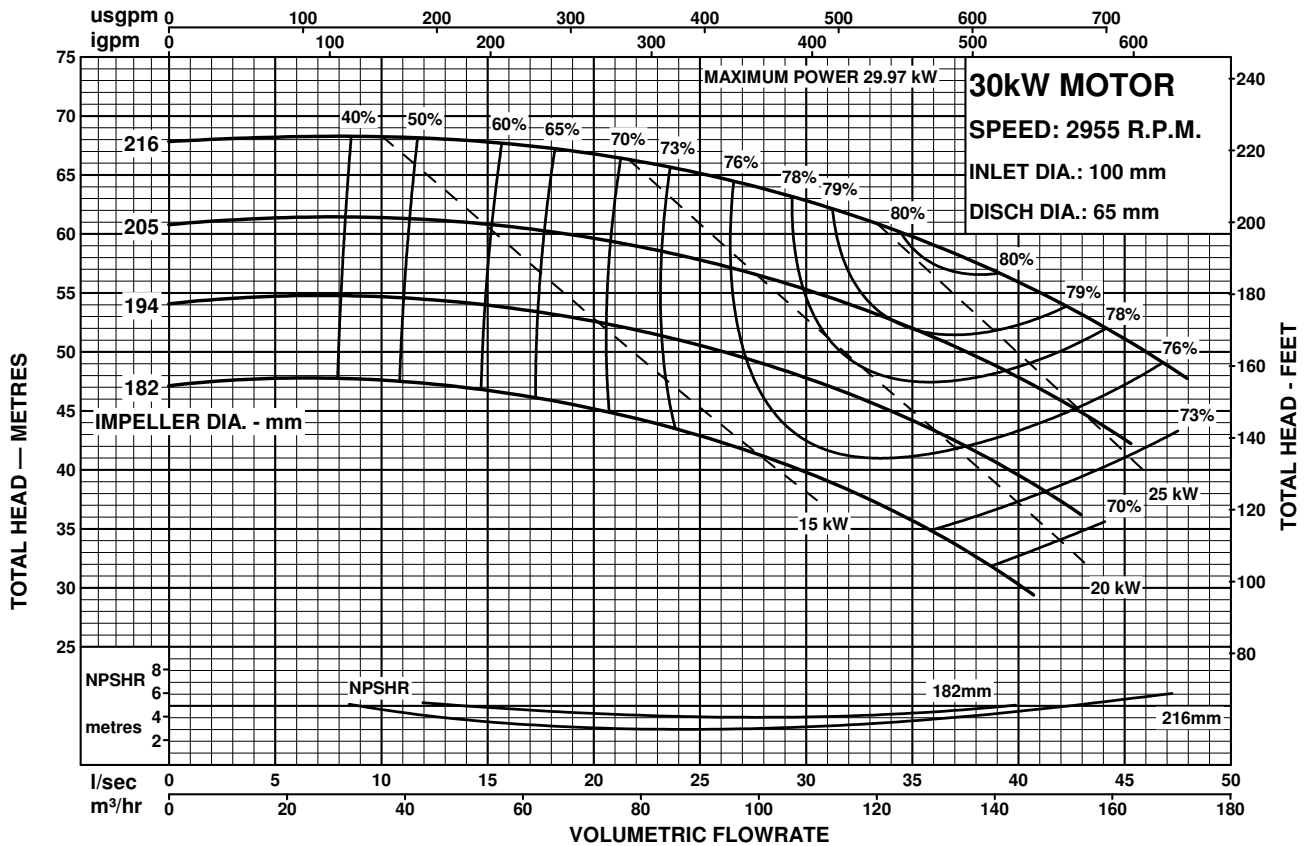

Performance to AS2417 Grade 2 for clean, cold water only.





# PENTAIR STARLINE

MOTORPUMPS

50Hz PERFORMANCE

## MODEL 100x65-200

CENTRIFUGAL PUMP PERFORMANCE DATA

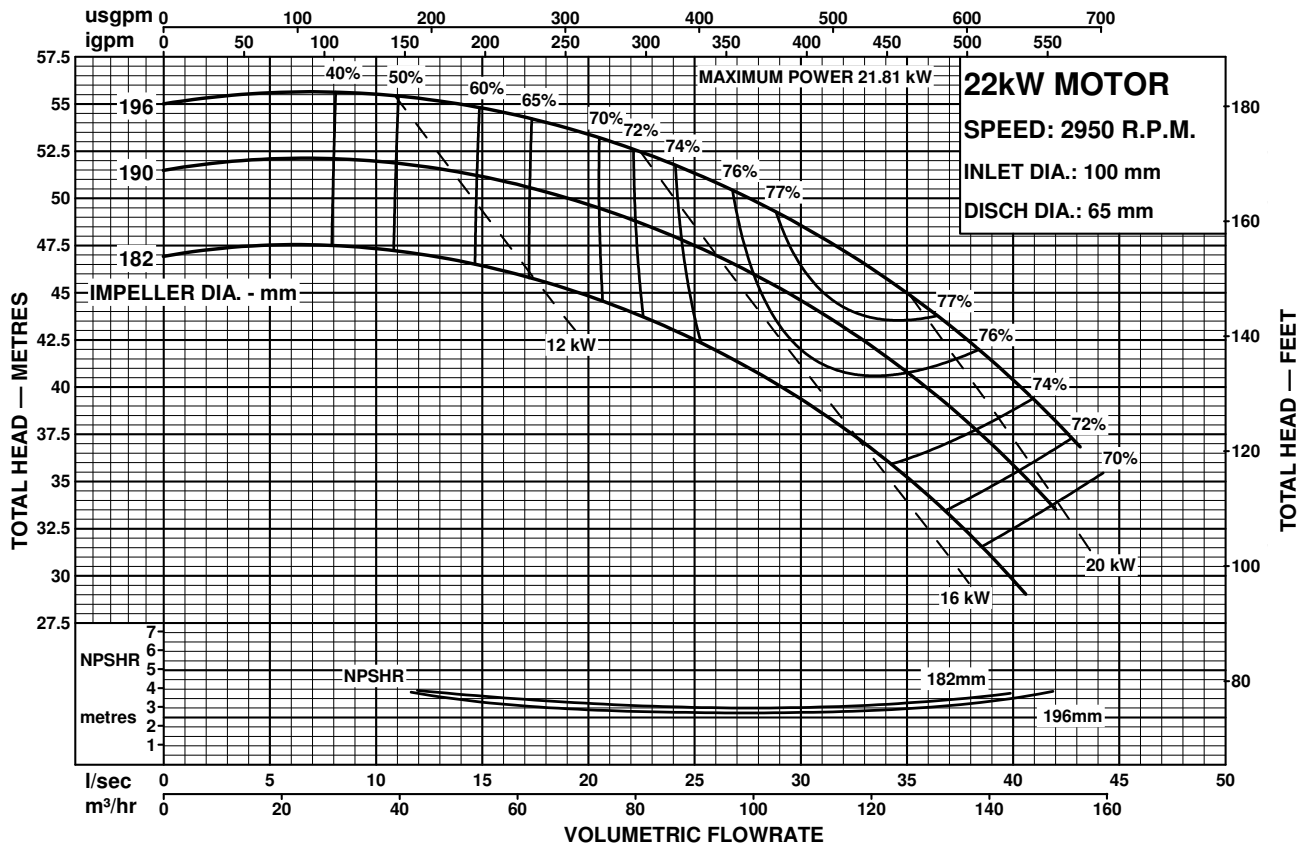

Performance to AS2417 Grade 2 for clean, cold water only.

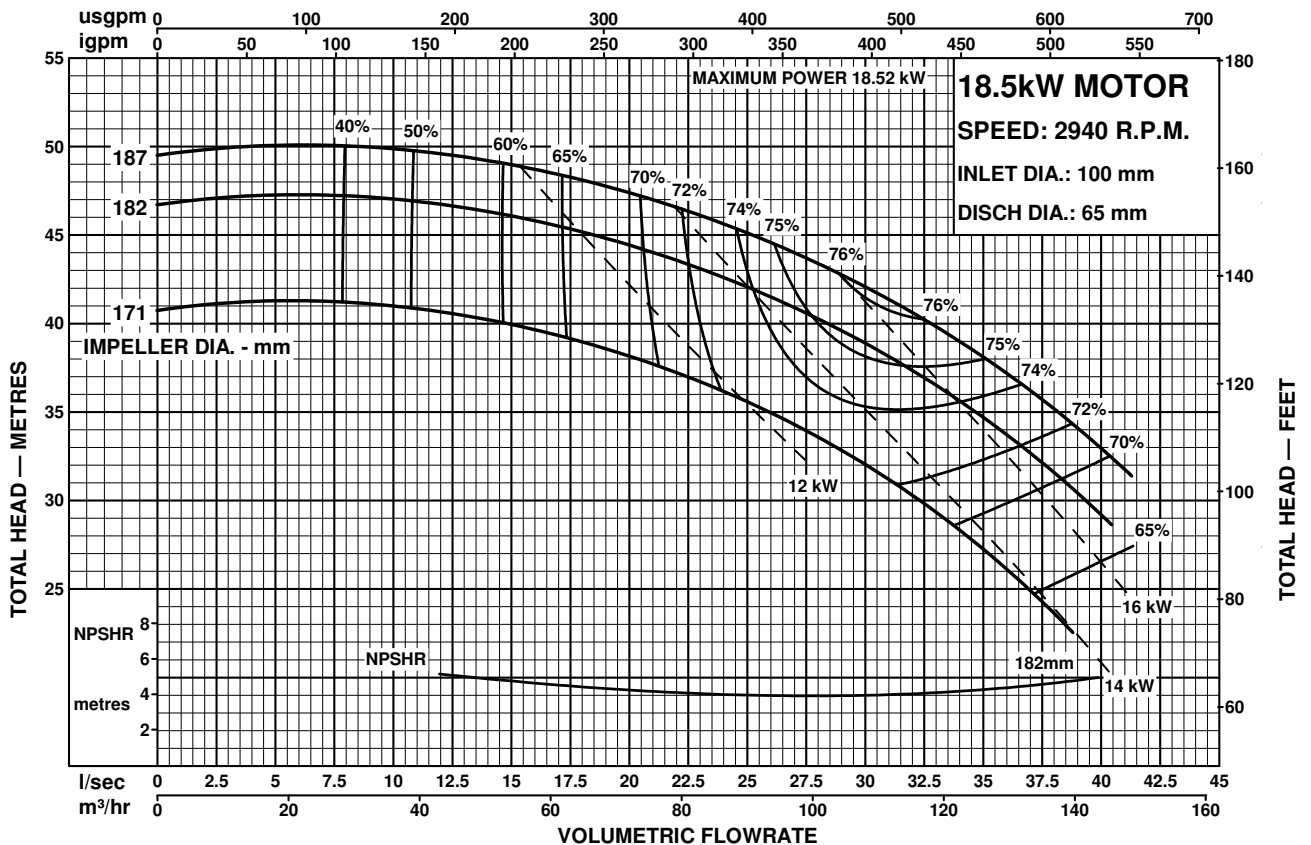

Performance to AS2417 Grade 2 for clean, cold water only.





# PENTAIR STARLINE

MOTORPUMPS  
50Hz PERFORMANCE

MODEL  
**100x65-250**

CENTRIFUGAL PUMP PERFORMANCE DATA

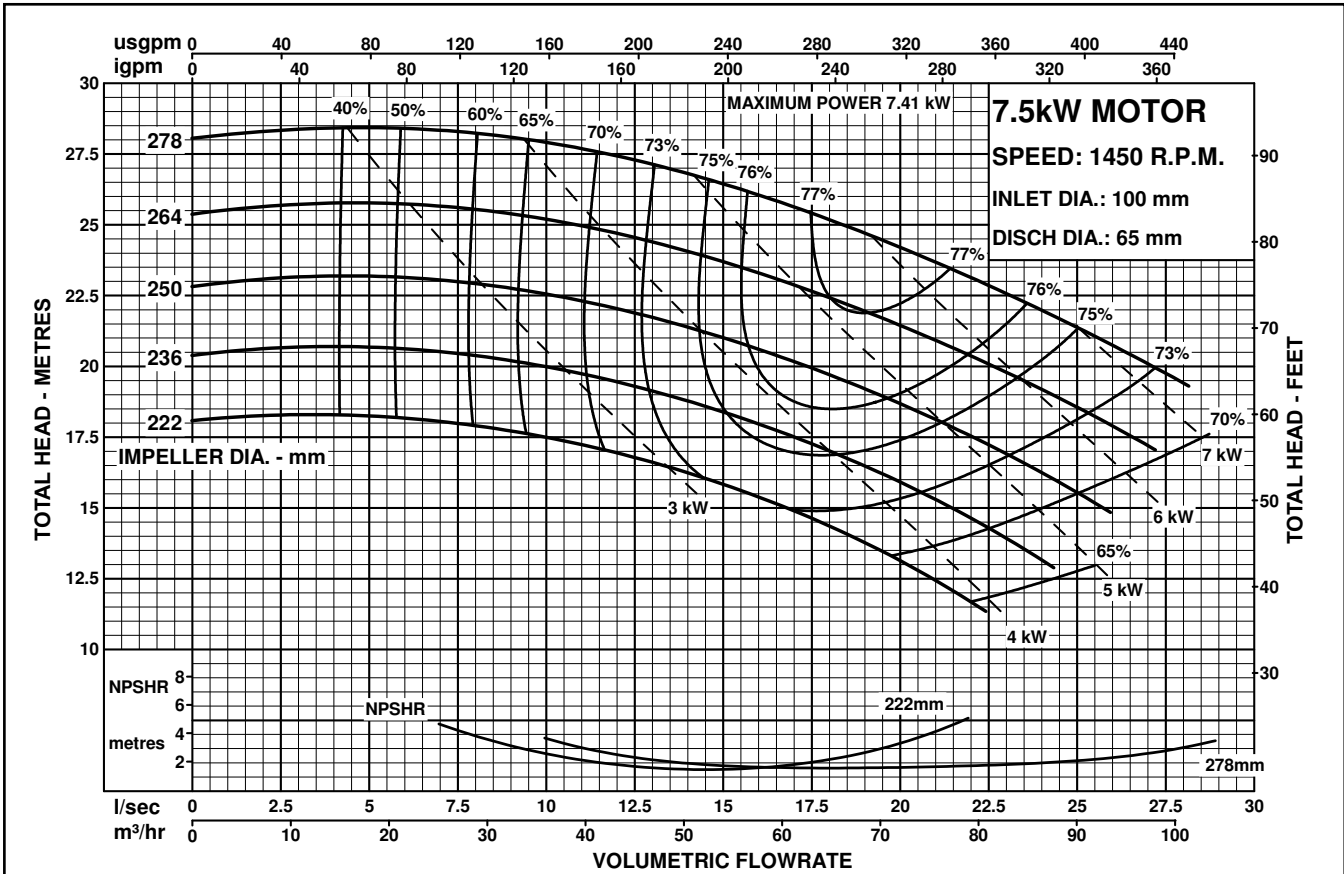

Performance to AS2417 Grade 2 for clean, cold water only.

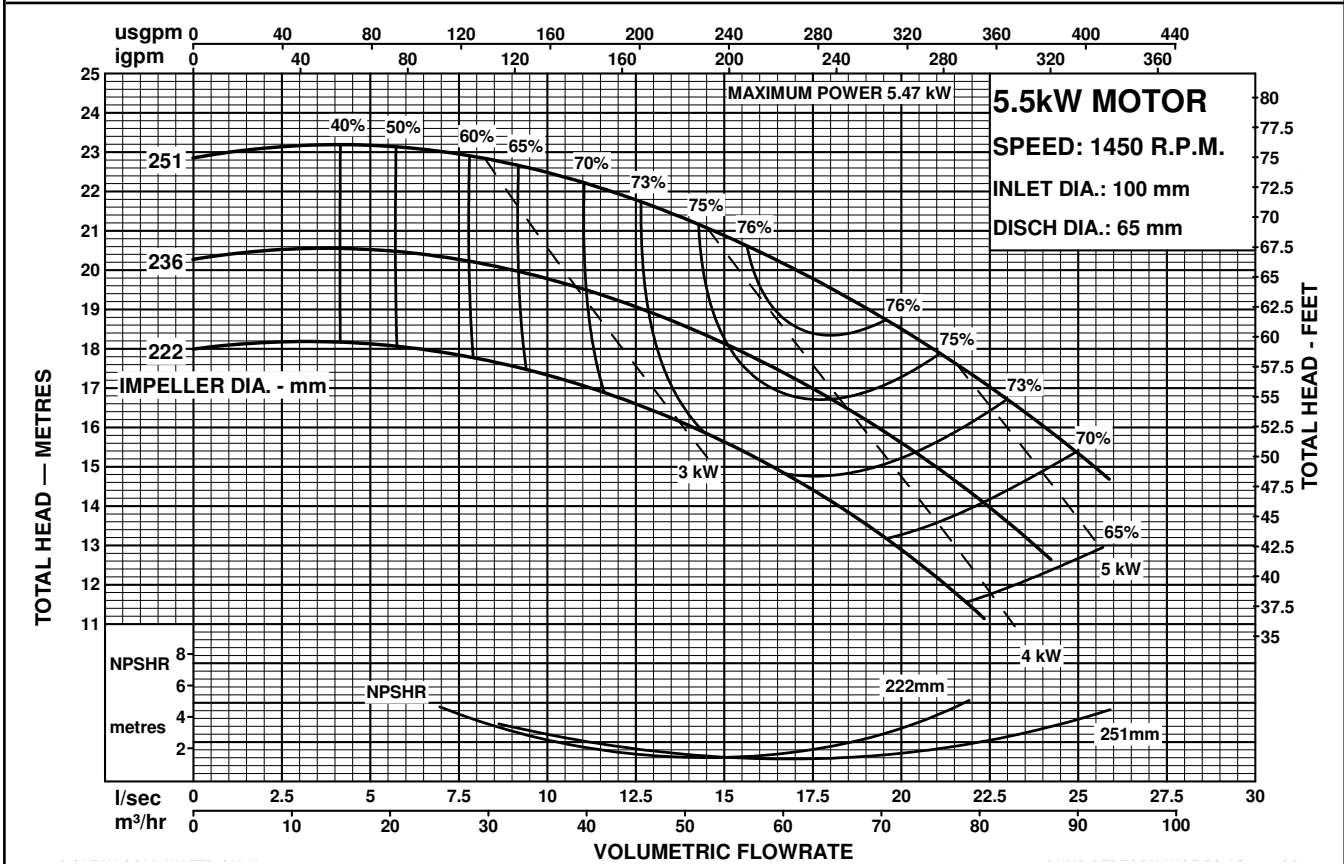

Performance to AS2417 Grade 2 for clean, cold water only.





# PENTAIR STARLINE

MOTORPUMPS  
50Hz PERFORMANCE

MODEL  
**100x65-250**

CENTRIFUGAL PUMP PERFORMANCE DATA

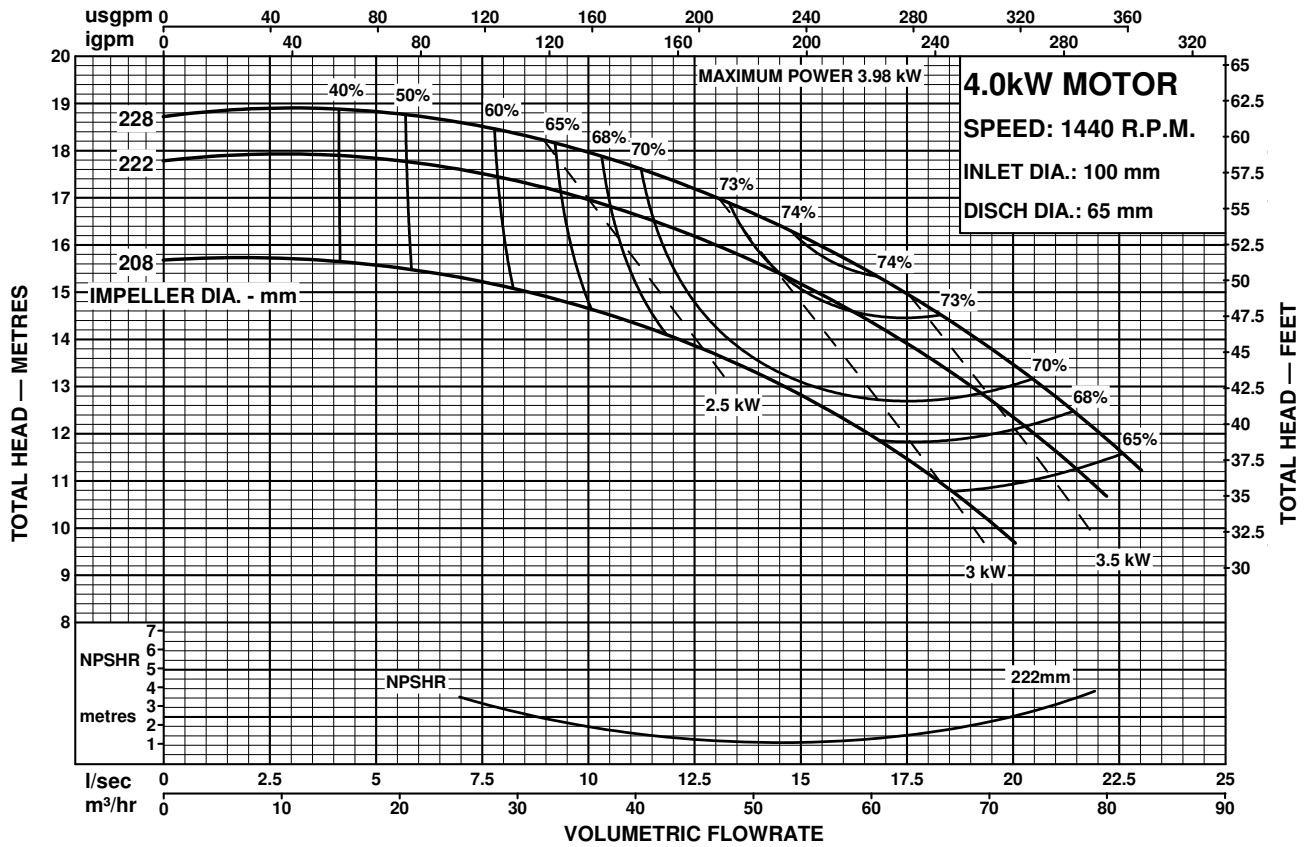

Performance to AS2417 Grade 2 for clean, cold water only.





# PENTAIR STARLINE

MOTORPUMPS  
50Hz PERFORMANCE

MODEL  
**100x65-250**

CENTRIFUGAL PUMP PERFORMANCE DATA

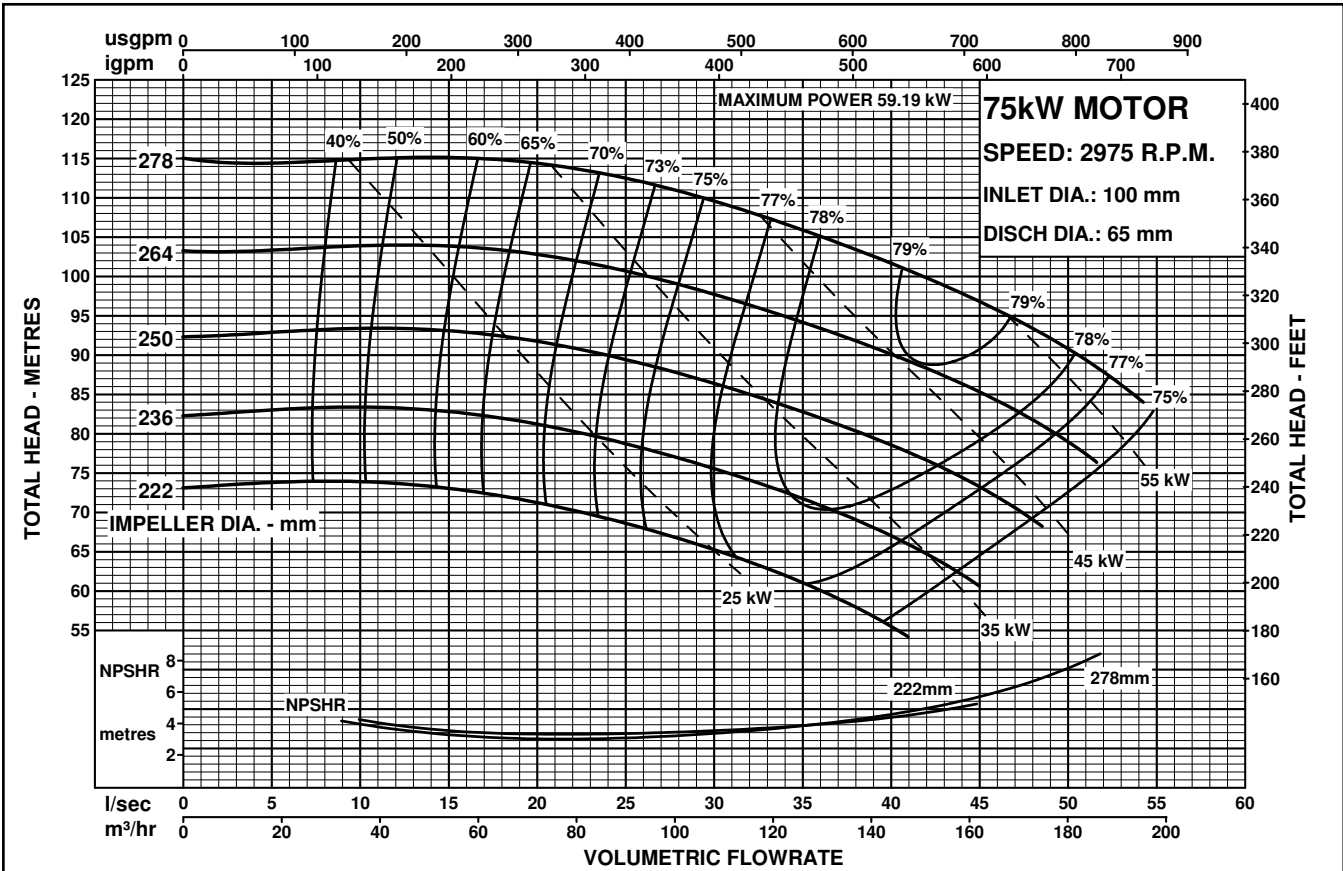

Performance to AS2417 Grade 2 for clean, cold water only.

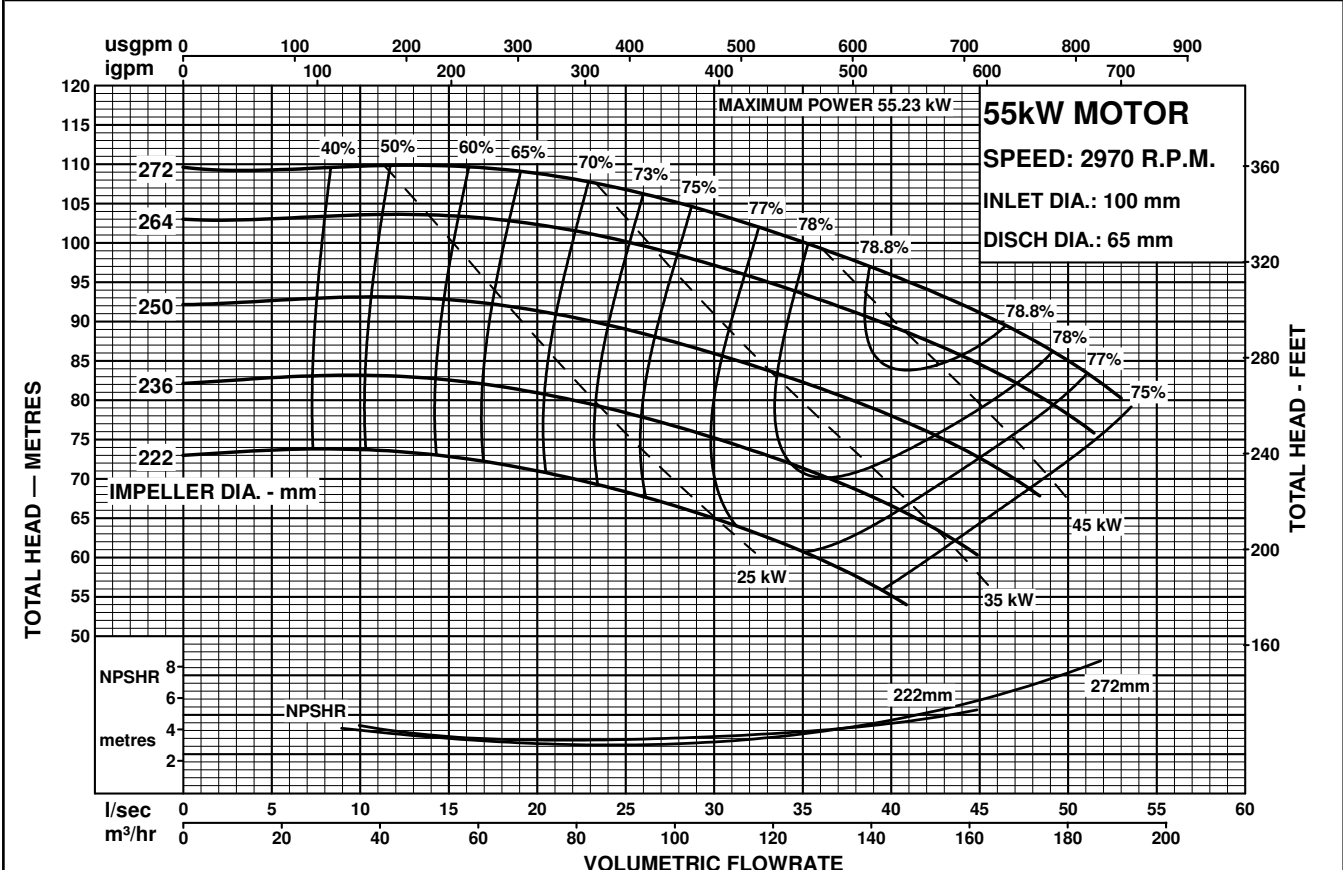

Performance to AS2417 Grade 2 for clean, cold water only.





# PENTAIR STARLINE

MOTORPUMPS

50Hz PERFORMANCE

## MODEL 100x65-250

CENTRIFUGAL PUMP PERFORMANCE DATA

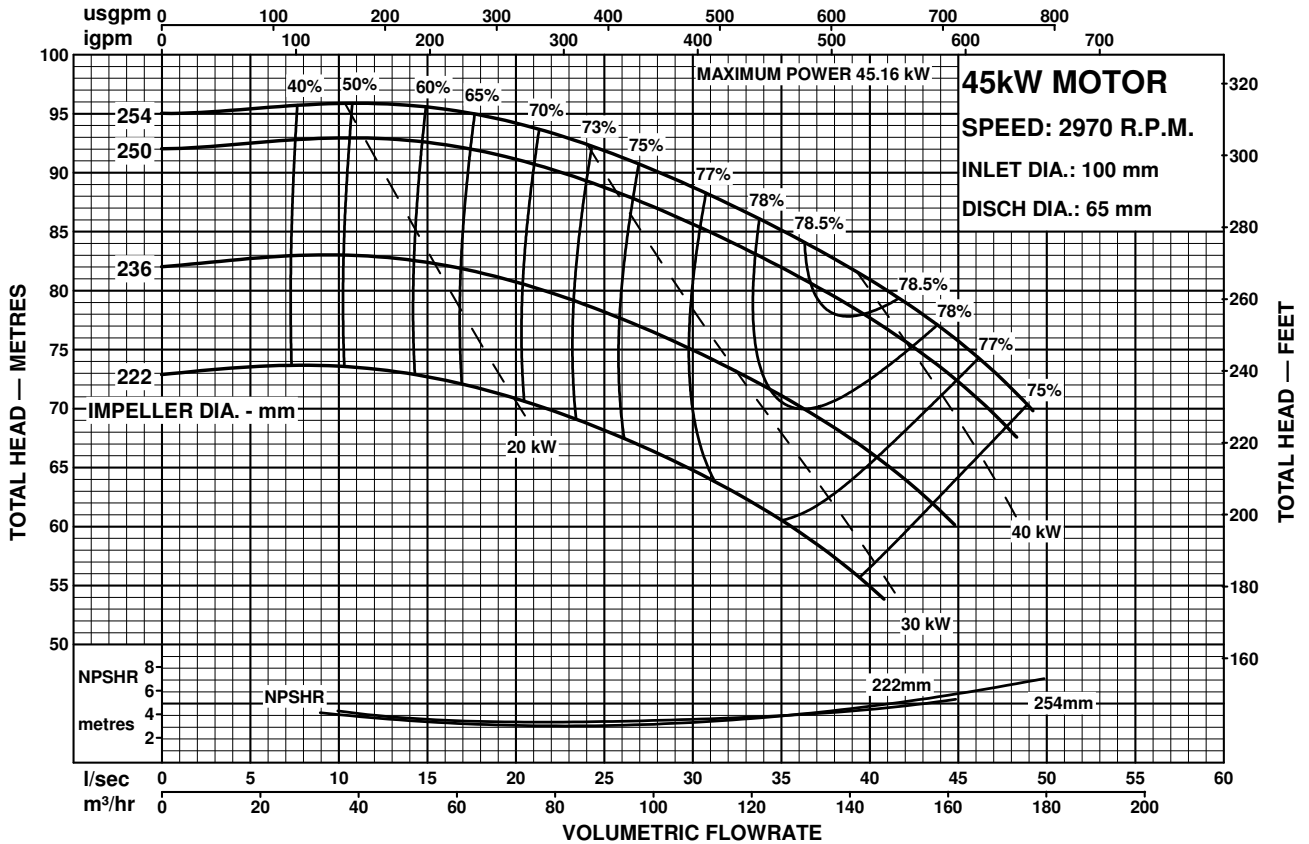

Performance to AS2417 Grade 2 for clean, cold water only.

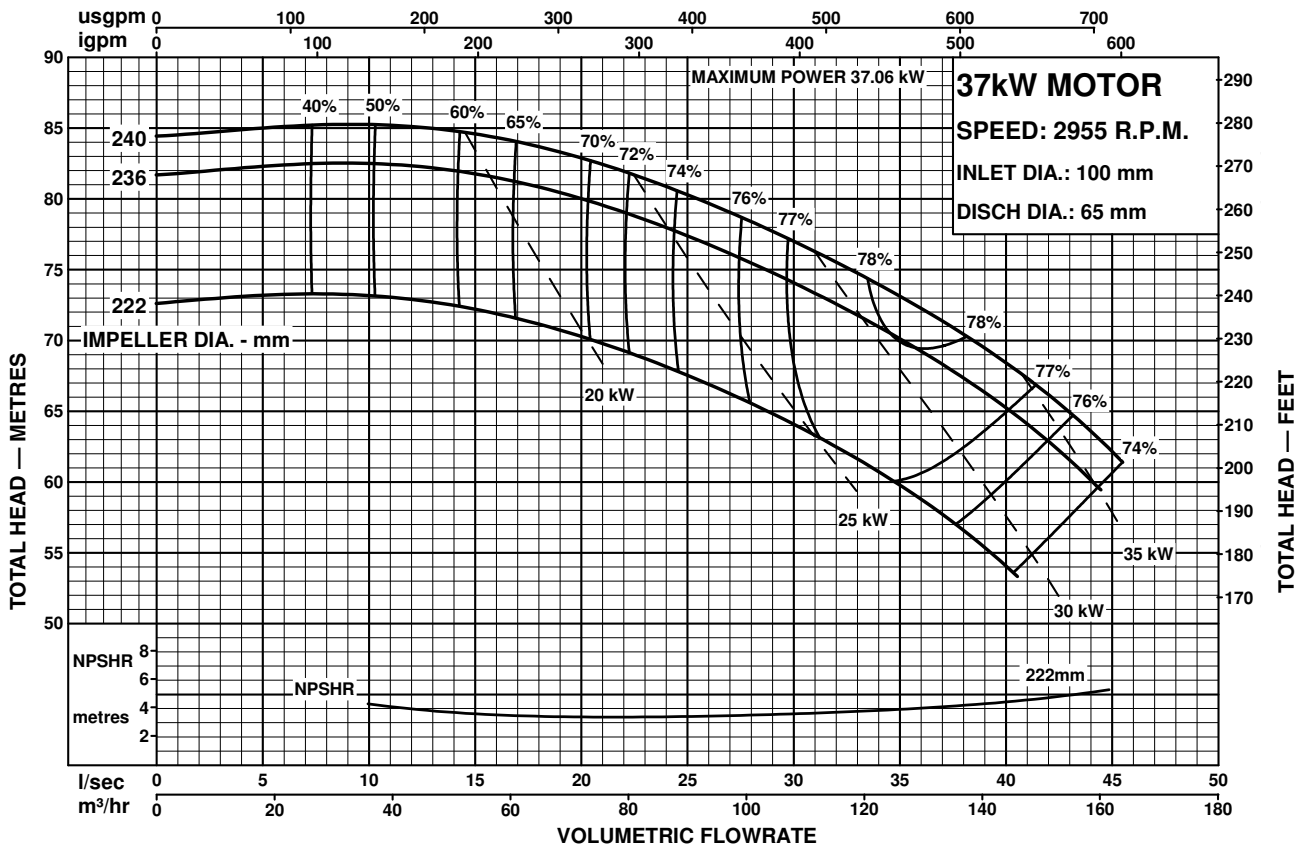

Performance to AS2417 Grade 2 for clean, cold water only.





# PENTAIR STARLINE

MOTORPUMPS  
50Hz PERFORMANCE

MODEL  
**100x65-250**

CENTRIFUGAL PUMP PERFORMANCE DATA

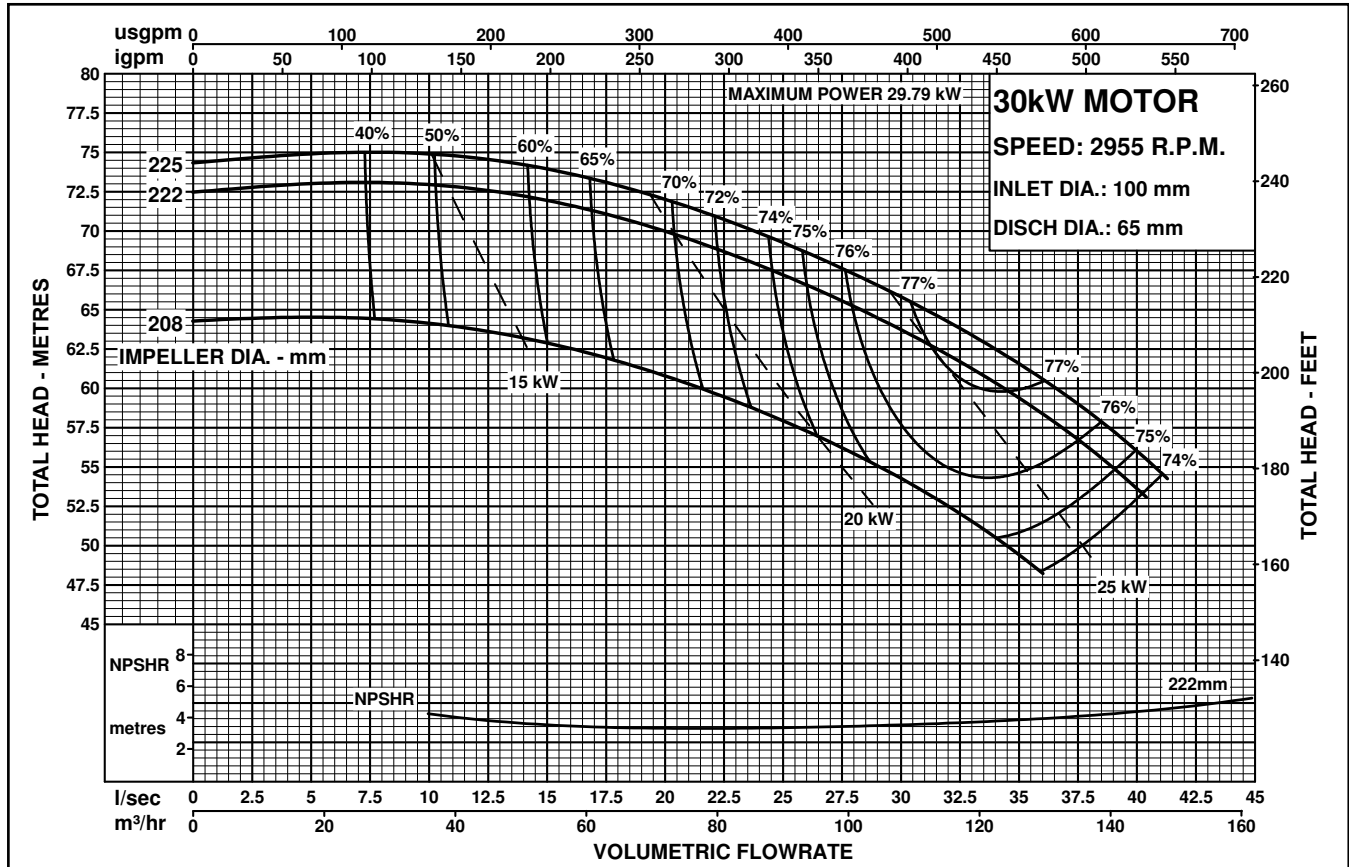

Performance to AS2417 Grade 2 for clean, cold water only.







# PENTAIR STARLINE

MOTORPUMPS

50Hz PERFORMANCE

MODEL

# 100x65-315

CENTRIFUGAL PUMP PERFORMANCE DATA

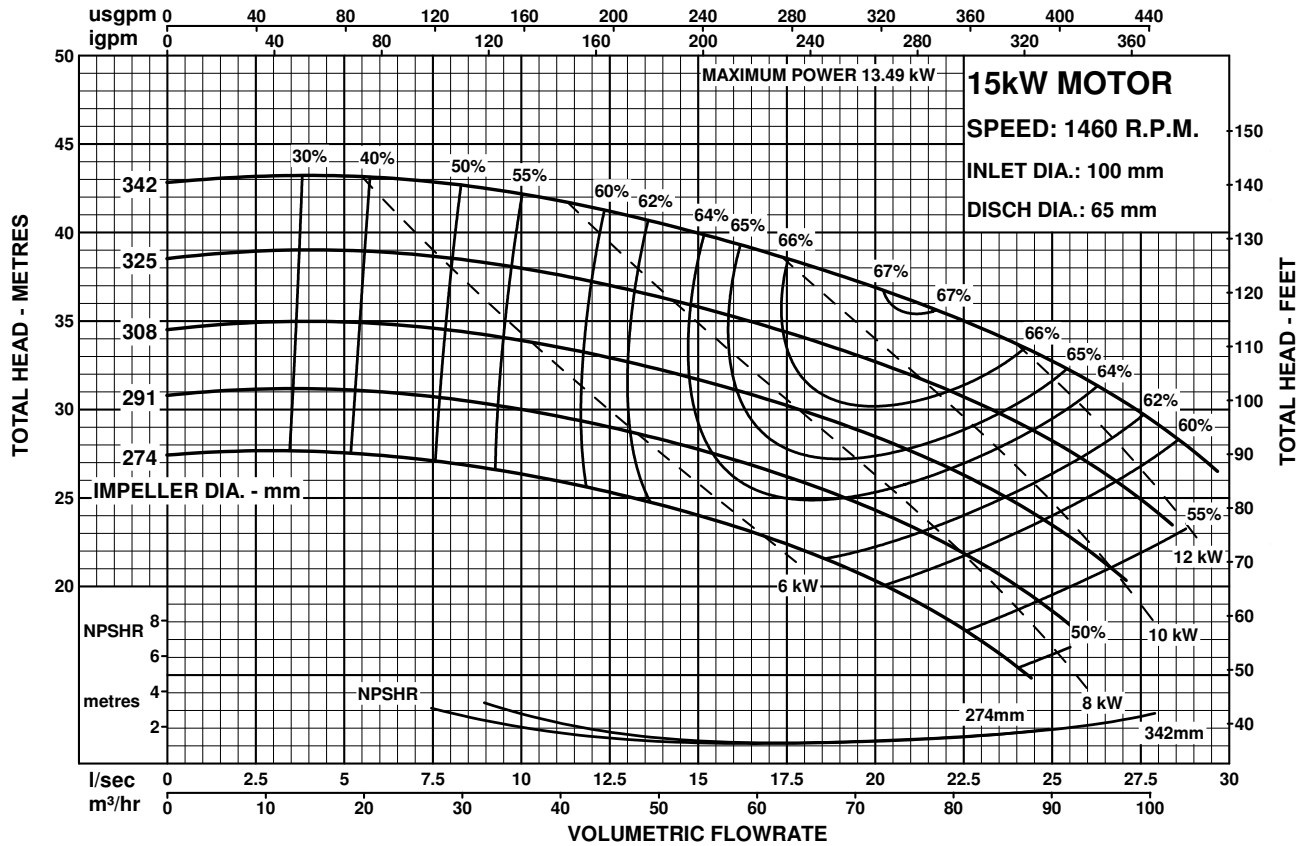

Performance to AS2417 Grade 2 for clean, cold water only.

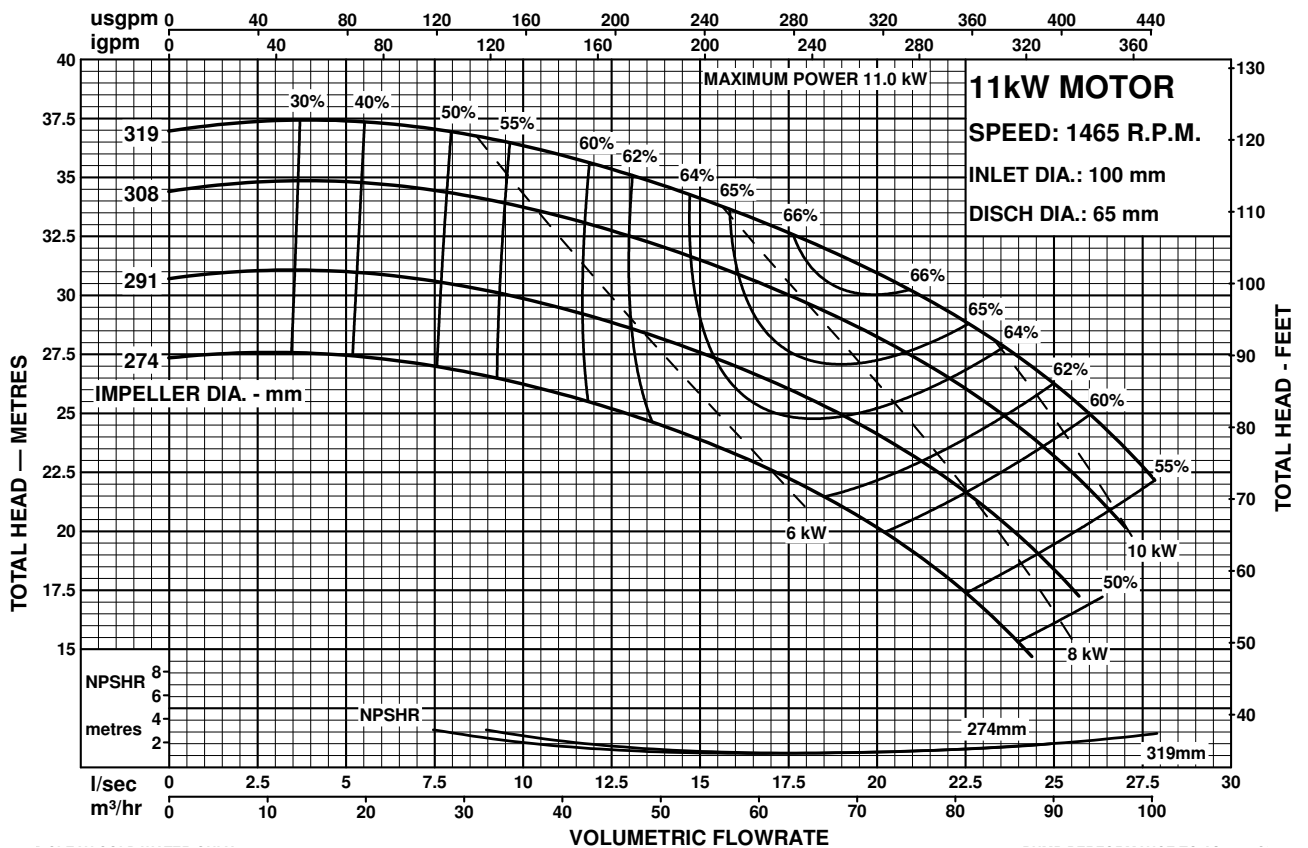

Performance to AS2417 Grade 2 for clean, cold water only.





# PENTAIR STARLINE

MOTORPUMPS  
50Hz PERFORMANCE

MODEL  
**100x65-315**

CENTRIFUGAL PUMP PERFORMANCE DATA

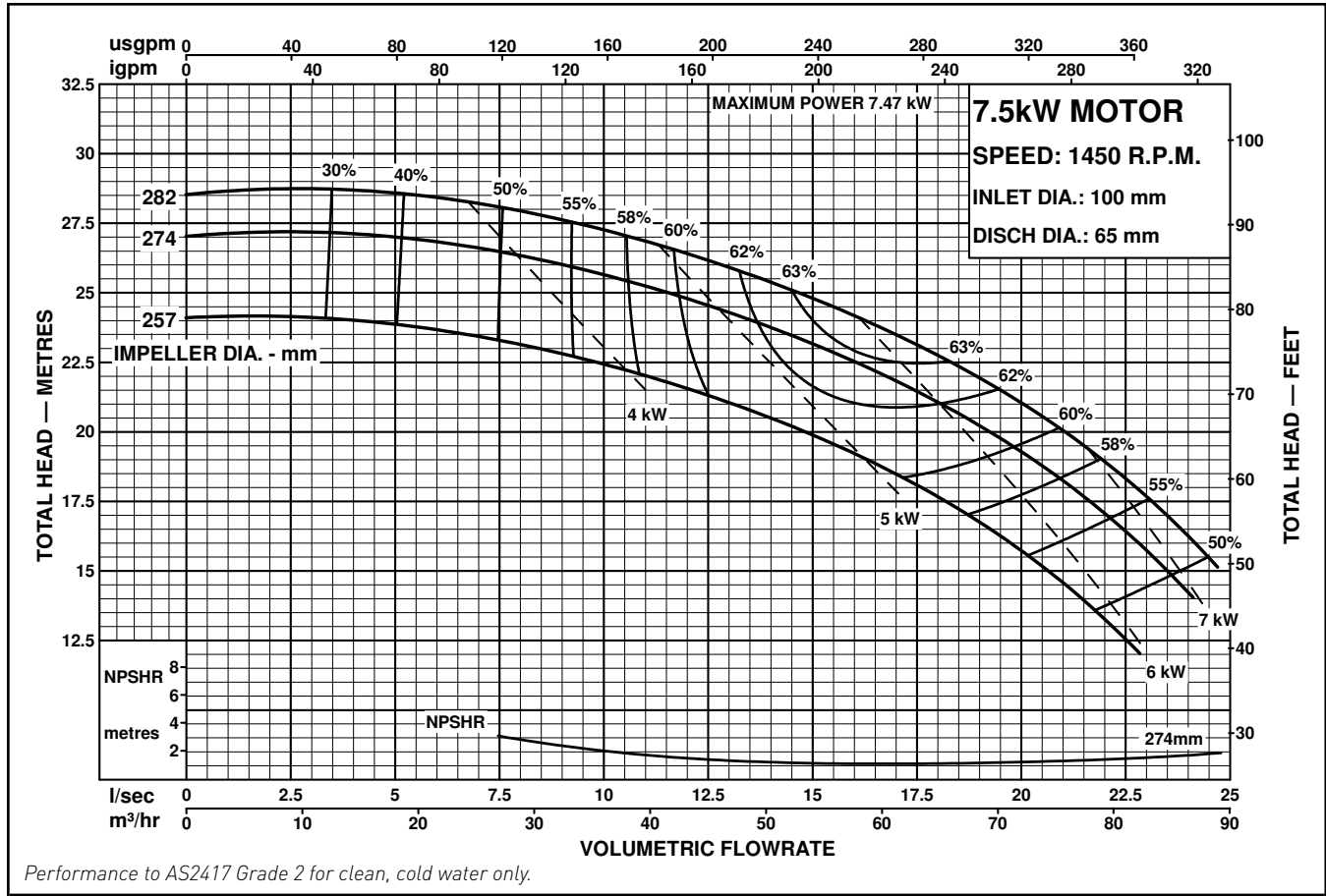



# PENTAIR STARLINE

MOTORPUMPS

50Hz PERFORMANCE

## MODEL 100x65-315

CENTRIFUGAL PUMP PERFORMANCE DATA

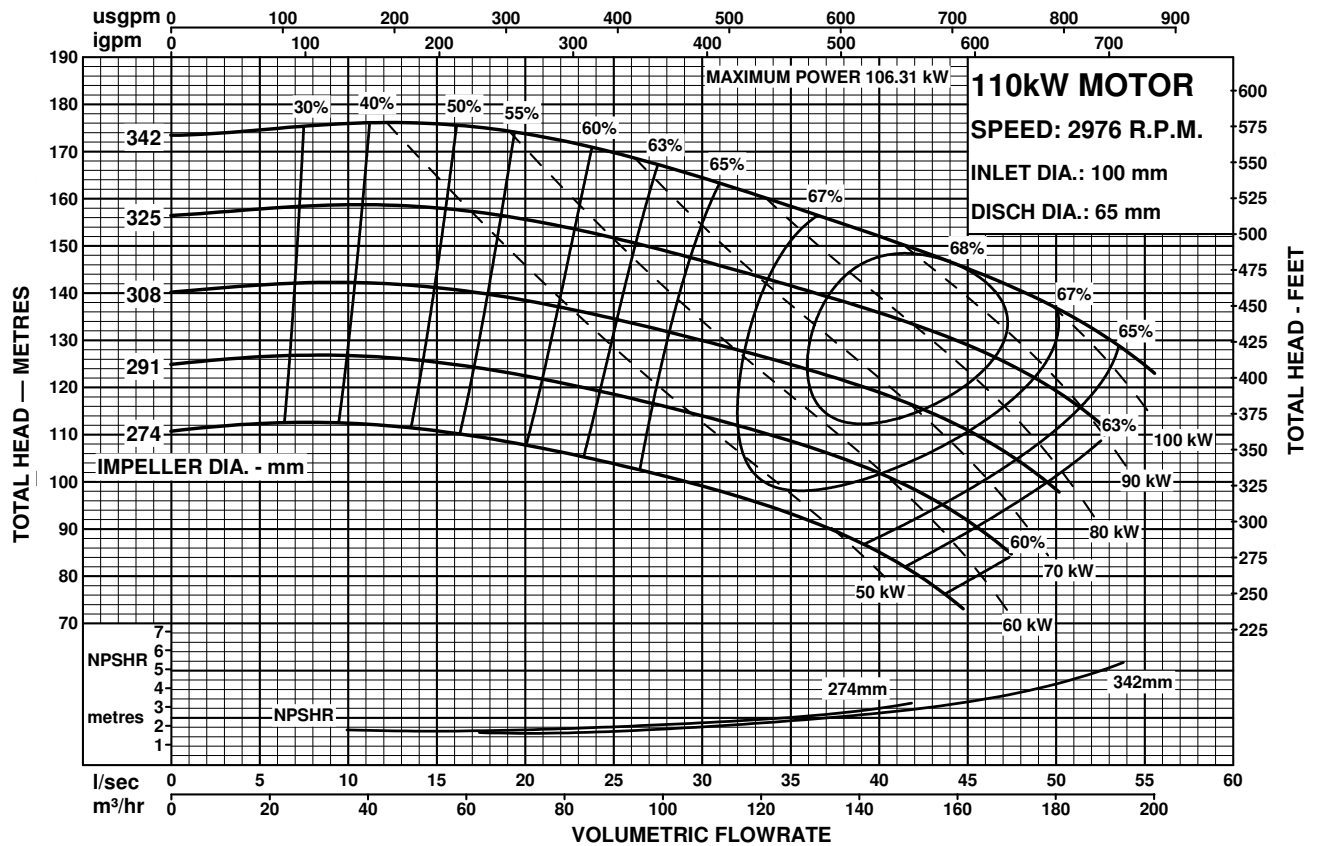

Performance to AS2417 Grade 2 for clean, cold water only.

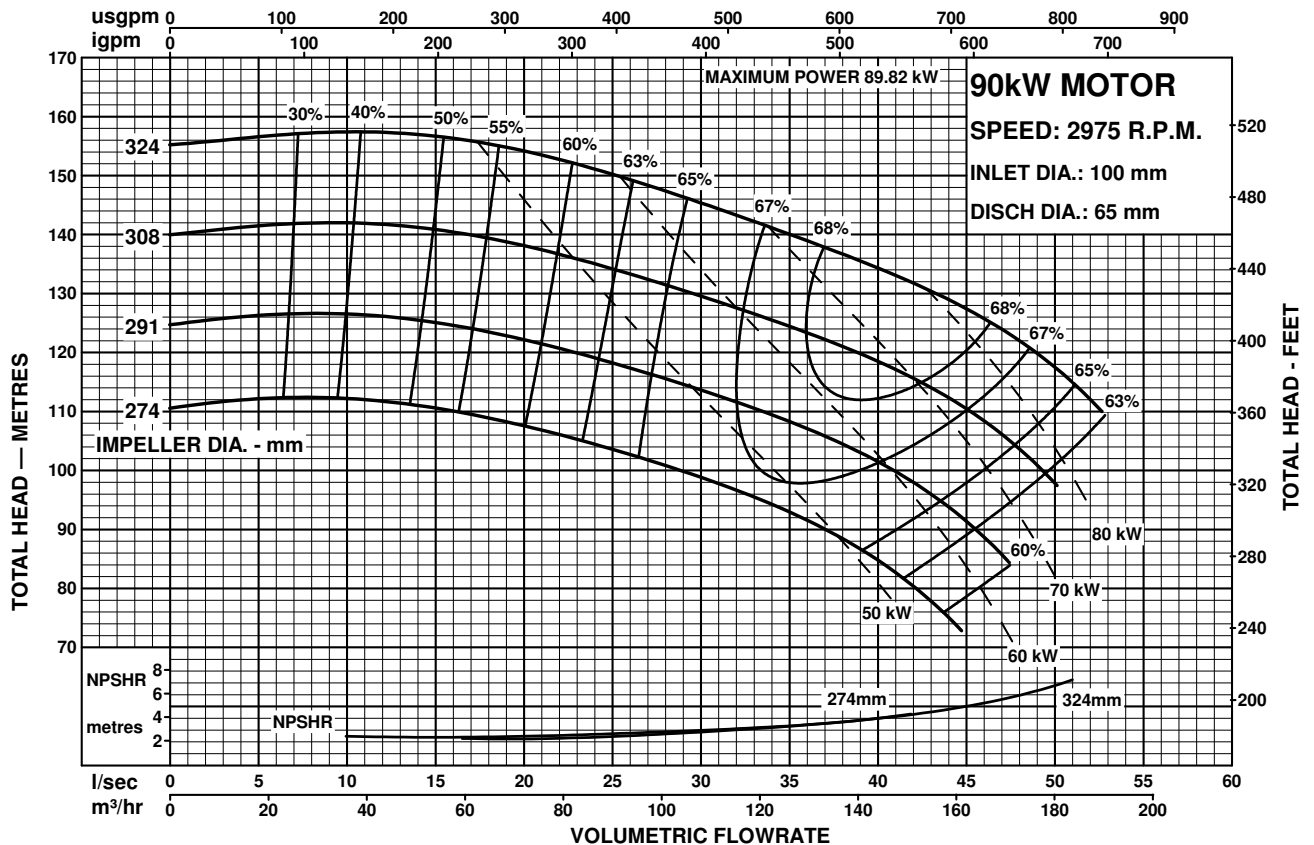

Performance to AS2417 Grade 2 for clean, cold water only.





# PENTAIR STARLINE

MOTORPUMPS  
50Hz PERFORMANCE

MODEL  
**100x65-315**

CENTRIFUGAL PUMP PERFORMANCE DATA

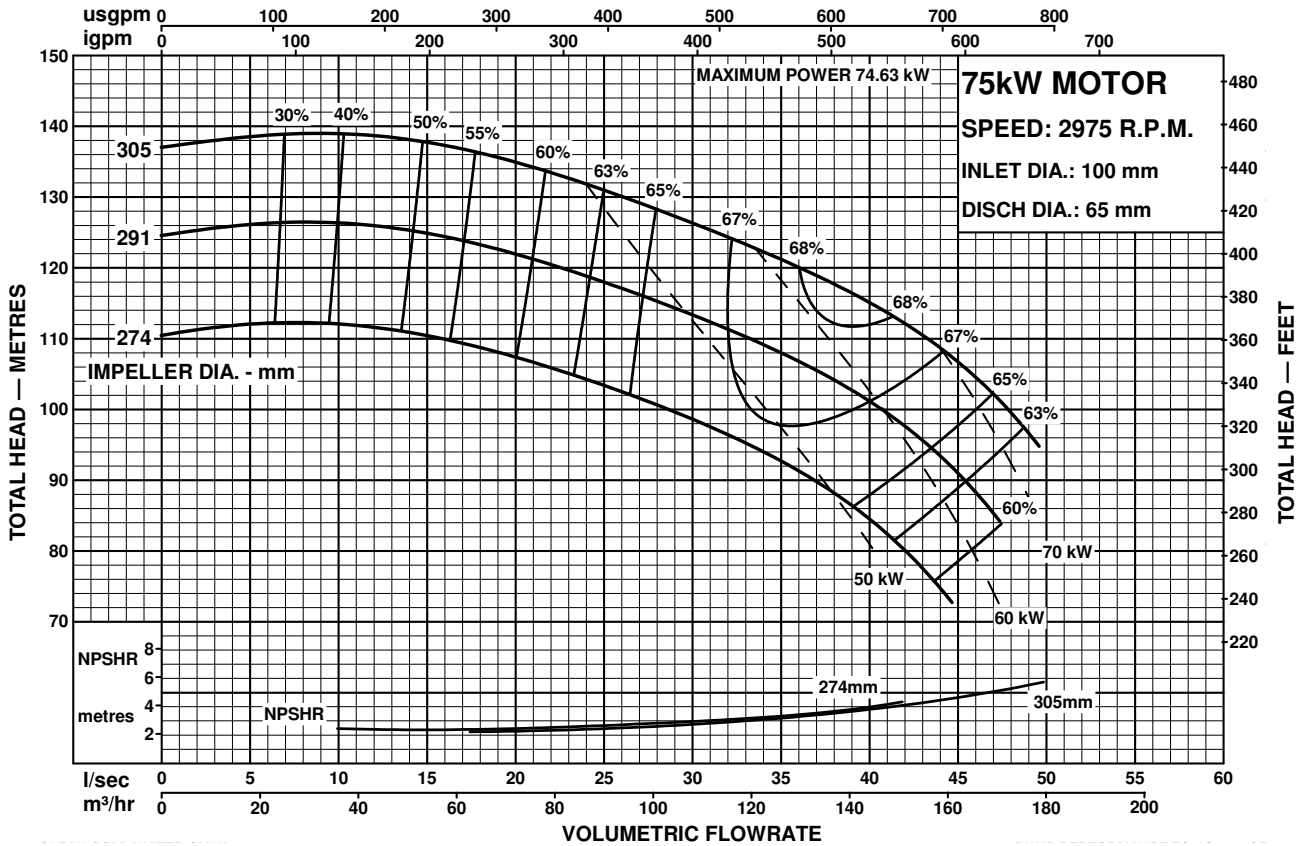

Performance to AS2417 Grade 2 for clean, cold water only.

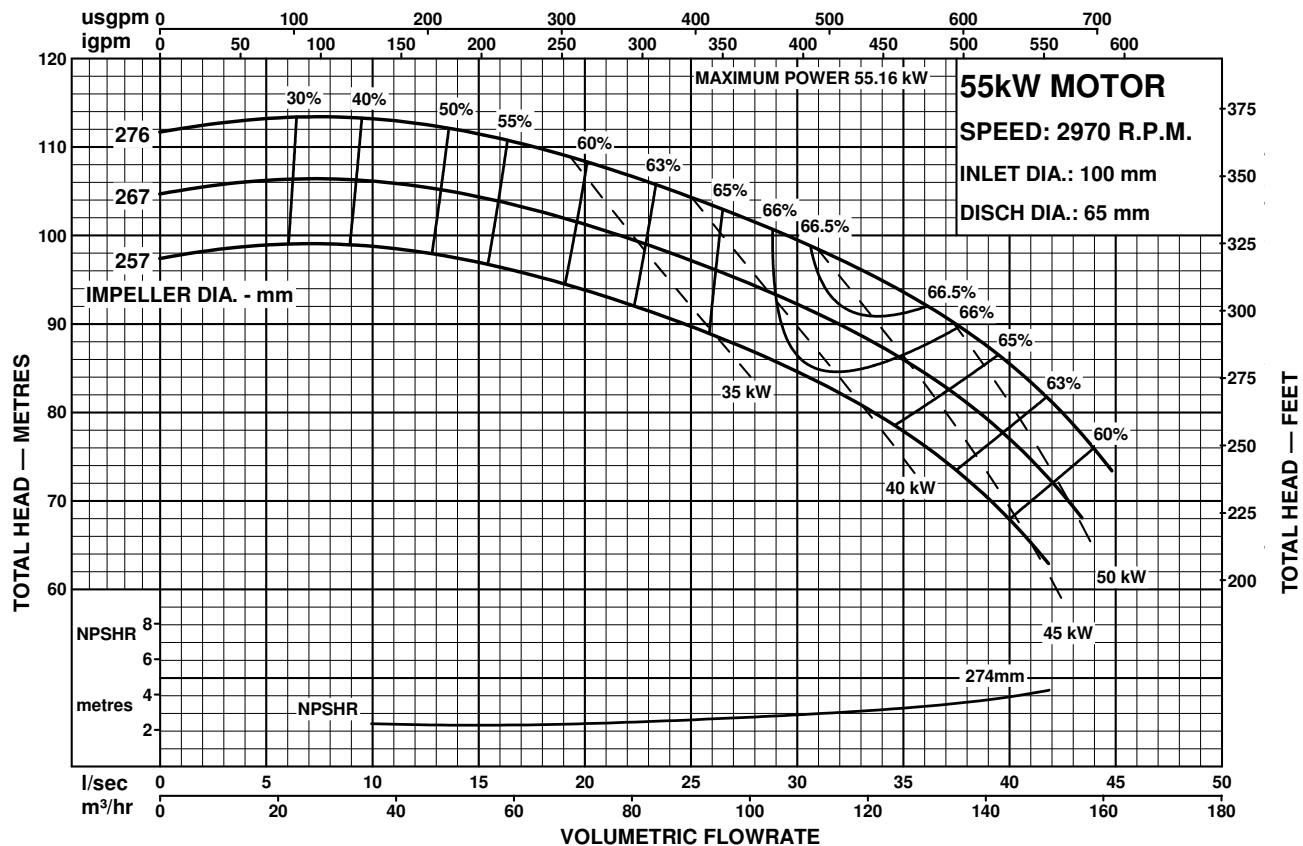

Performance to AS2417 Grade 2 for clean, cold water only.





# PENTAIR STARLINE

MOTORPUMPS

50Hz PERFORMANCE

MODEL  
**125x80-200**

CENTRIFUGAL PUMP PERFORMANCE DATA

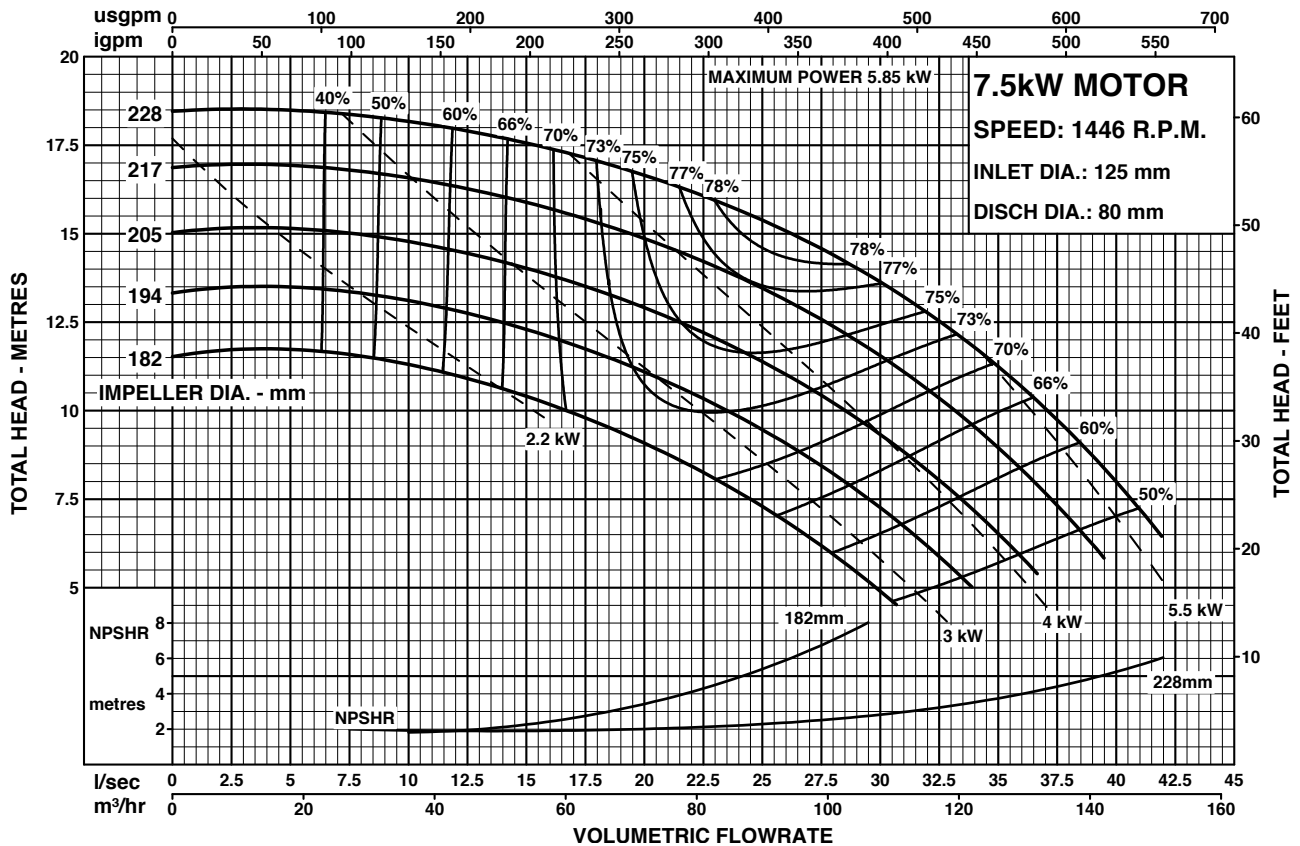

Performance to AS2417 Grade 2 for clean, cold water only.

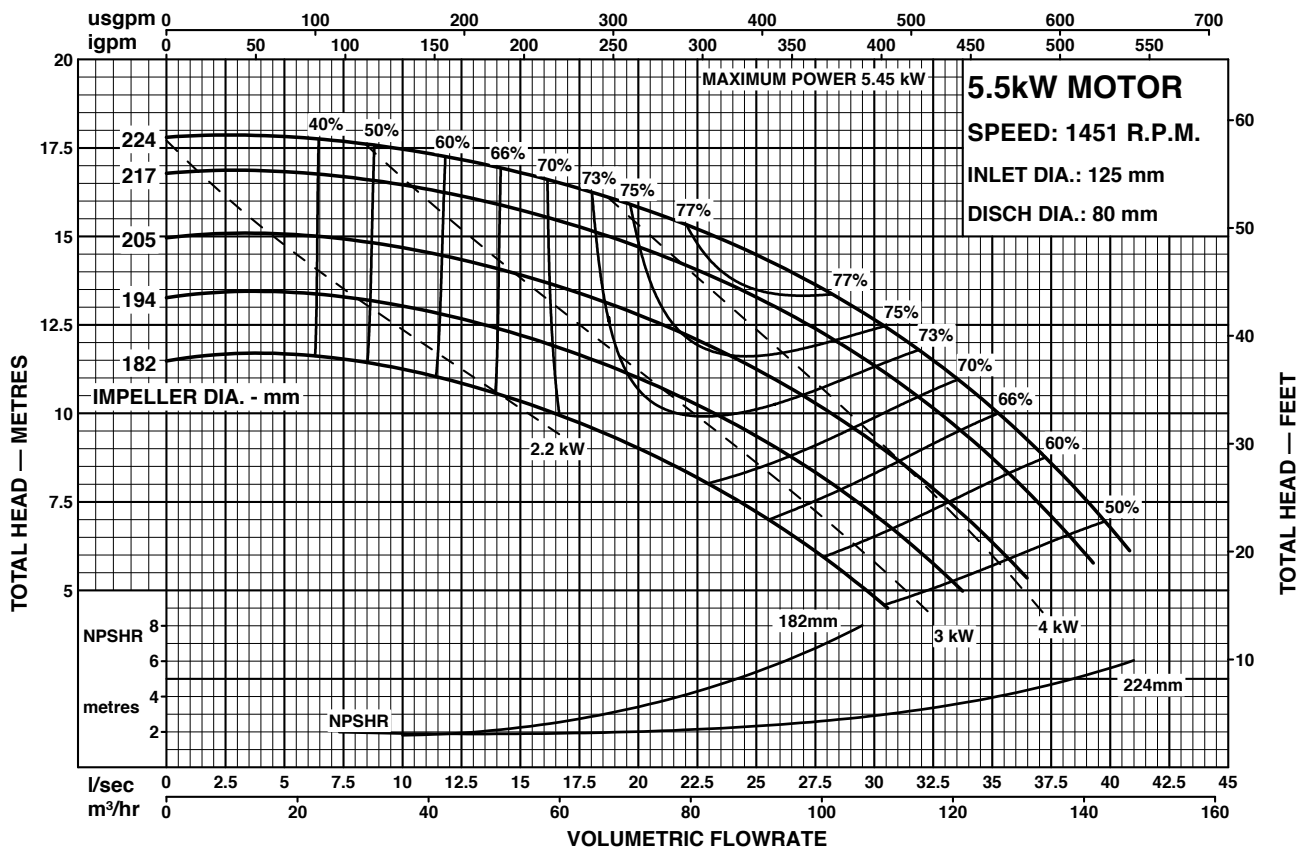

Performance to AS2417 Grade 2 for clean, cold water only.





# PENTAIR STARLINE

MOTORPUMPS  
50Hz PERFORMANCE

MODEL  
**125x80-200**

CENTRIFUGAL PUMP PERFORMANCE DATA

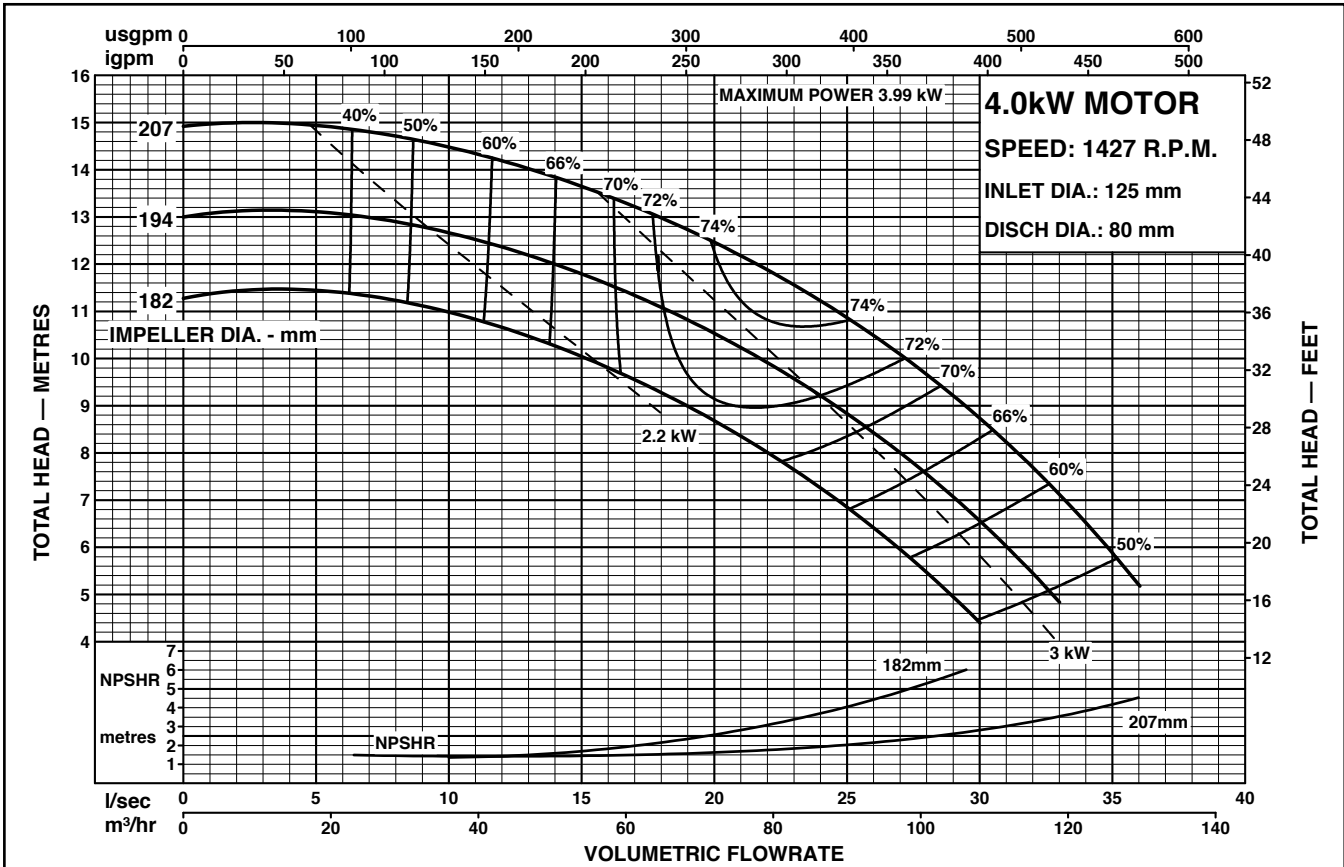

Performance to AS2417 Grade 2 for clean, cold water only.

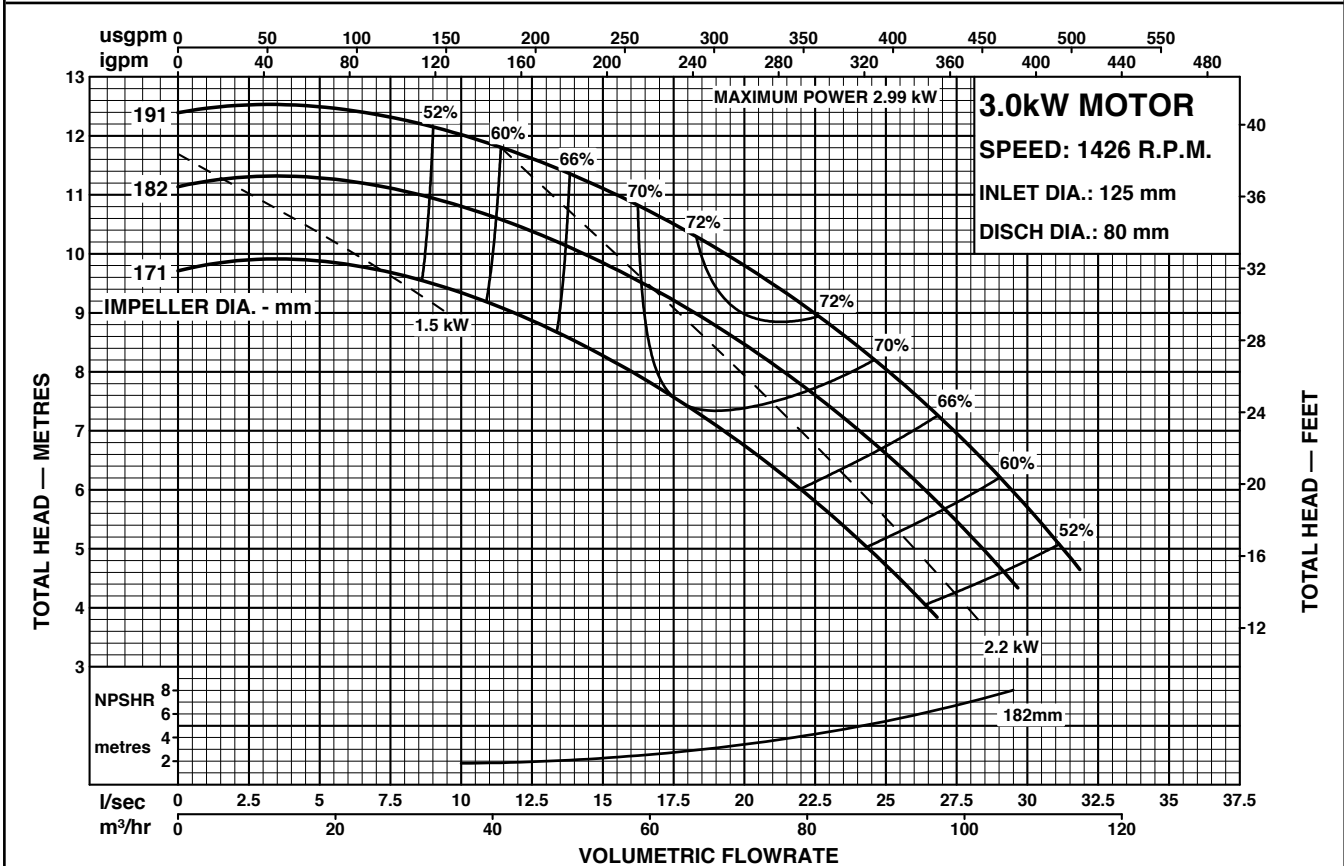

Performance to AS2417 Grade 2 for clean, cold water only.





# PENTAIR STARLINE

MOTORPUMPS

50Hz PERFORMANCE

## MODEL 125x80-200

CENTRIFUGAL PUMP PERFORMANCE DATA

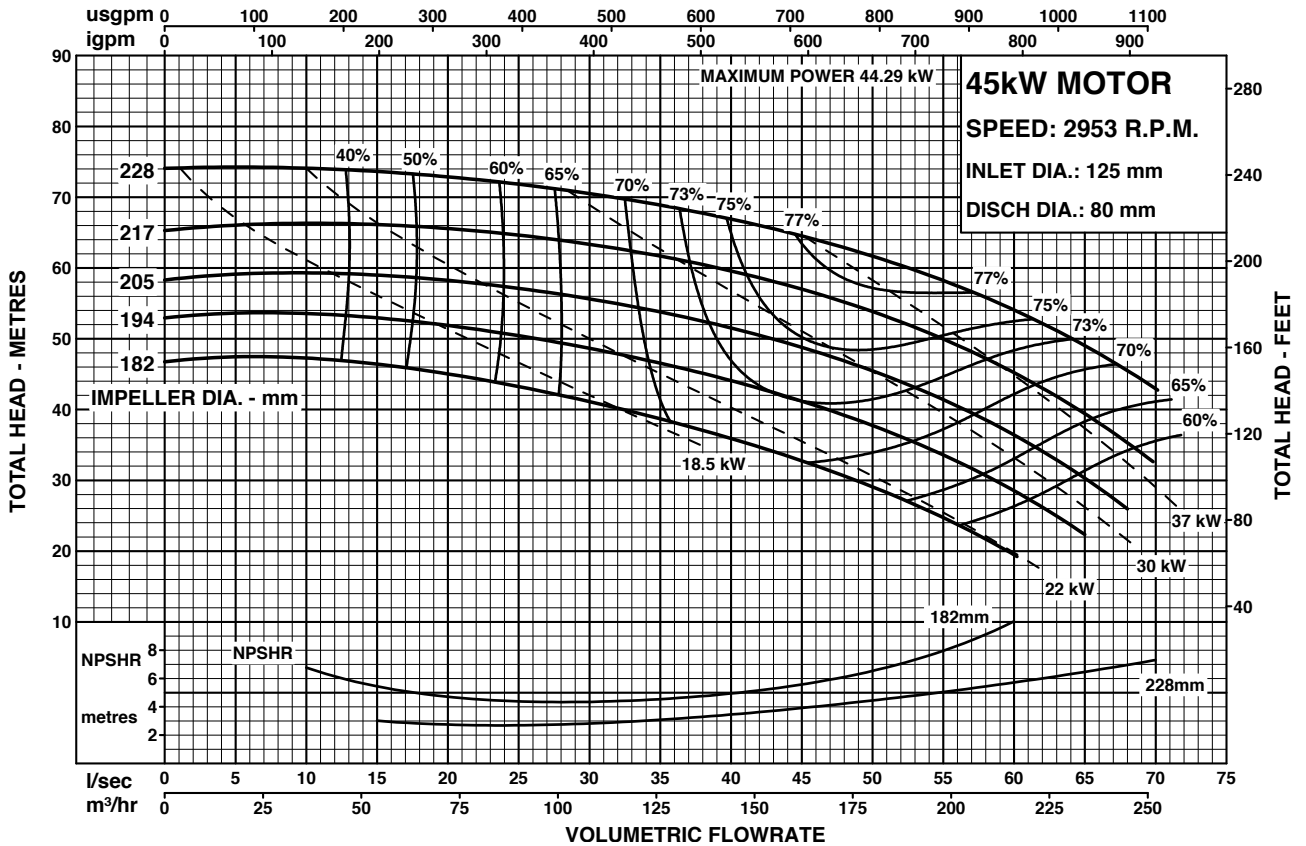

Performance to AS2417 Grade 2 for clean, cold water only.

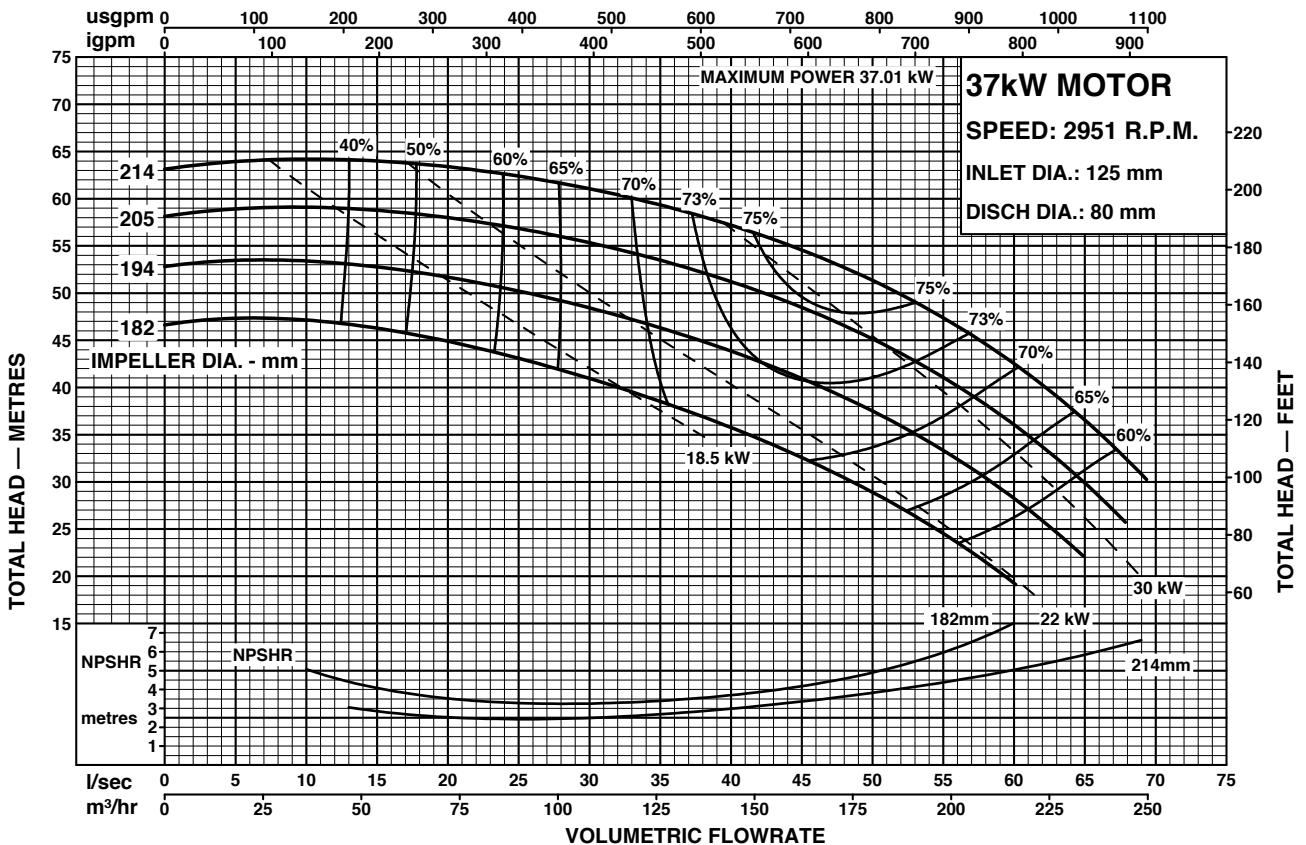

Performance to AS2417 Grade 2 for clean, cold water only.





# PENTAIR STARLINE

MOTORPUMPS  
50Hz PERFORMANCE

MODEL  
**125x80-200**

CENTRIFUGAL PUMP PERFORMANCE DATA

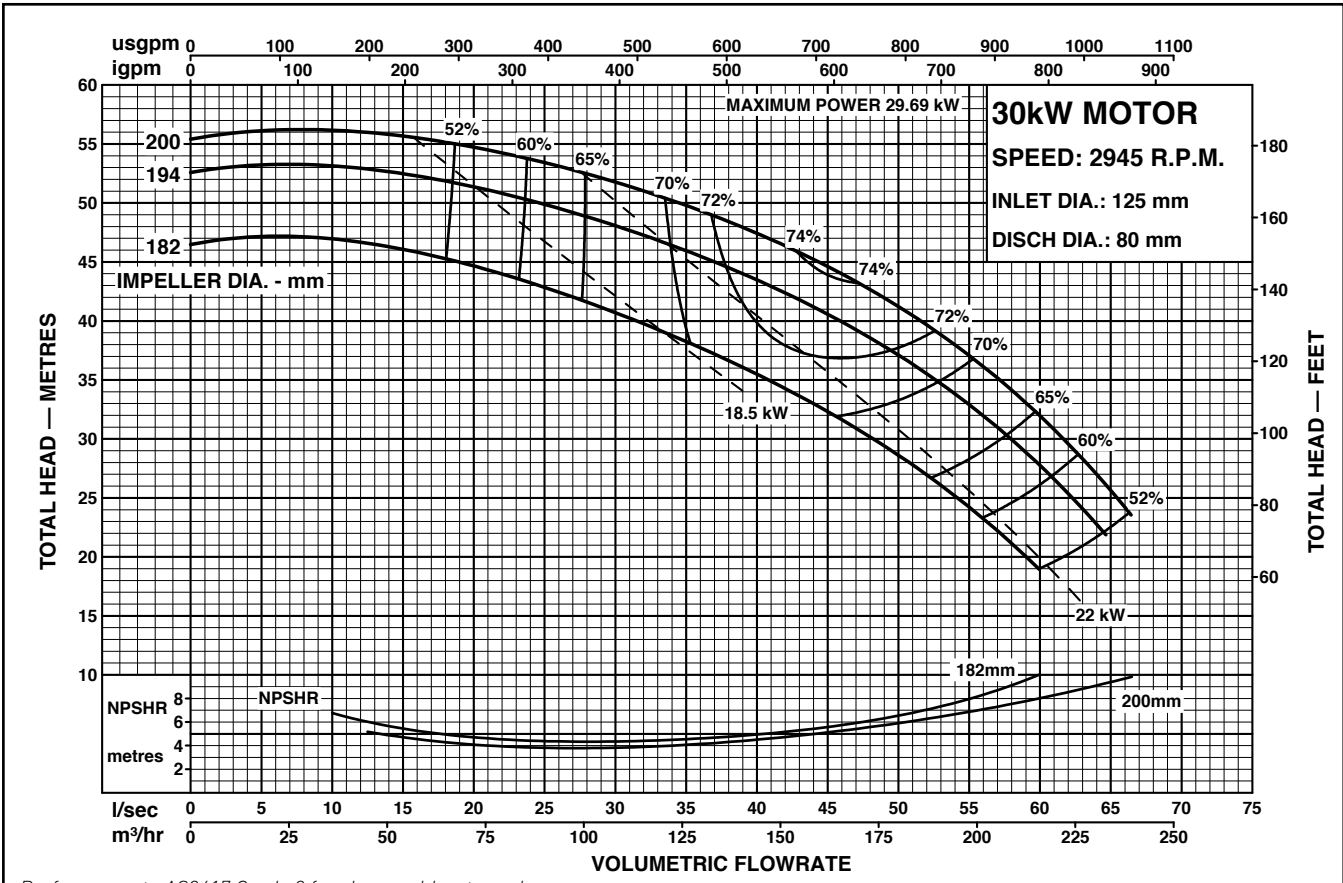

Performance to AS2417 Grade 2 for clean, cold water only.

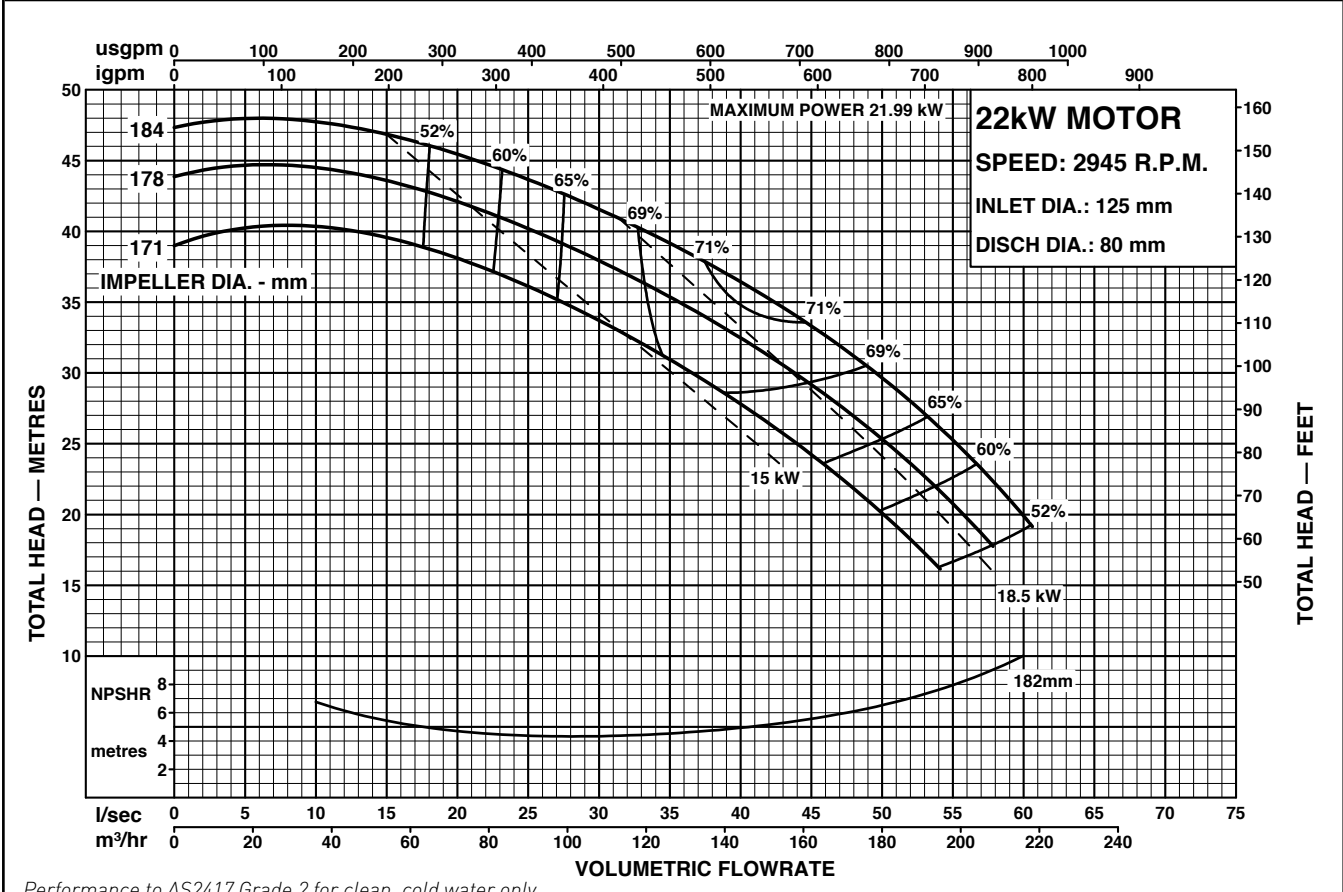

Performance to AS2417 Grade 2 for clean, cold water only.







# PENTAIR STARLINE

MOTORPUMPS

50Hz PERFORMANCE

## MODEL 125x80-250

CENTRIFUGAL PUMP PERFORMANCE DATA

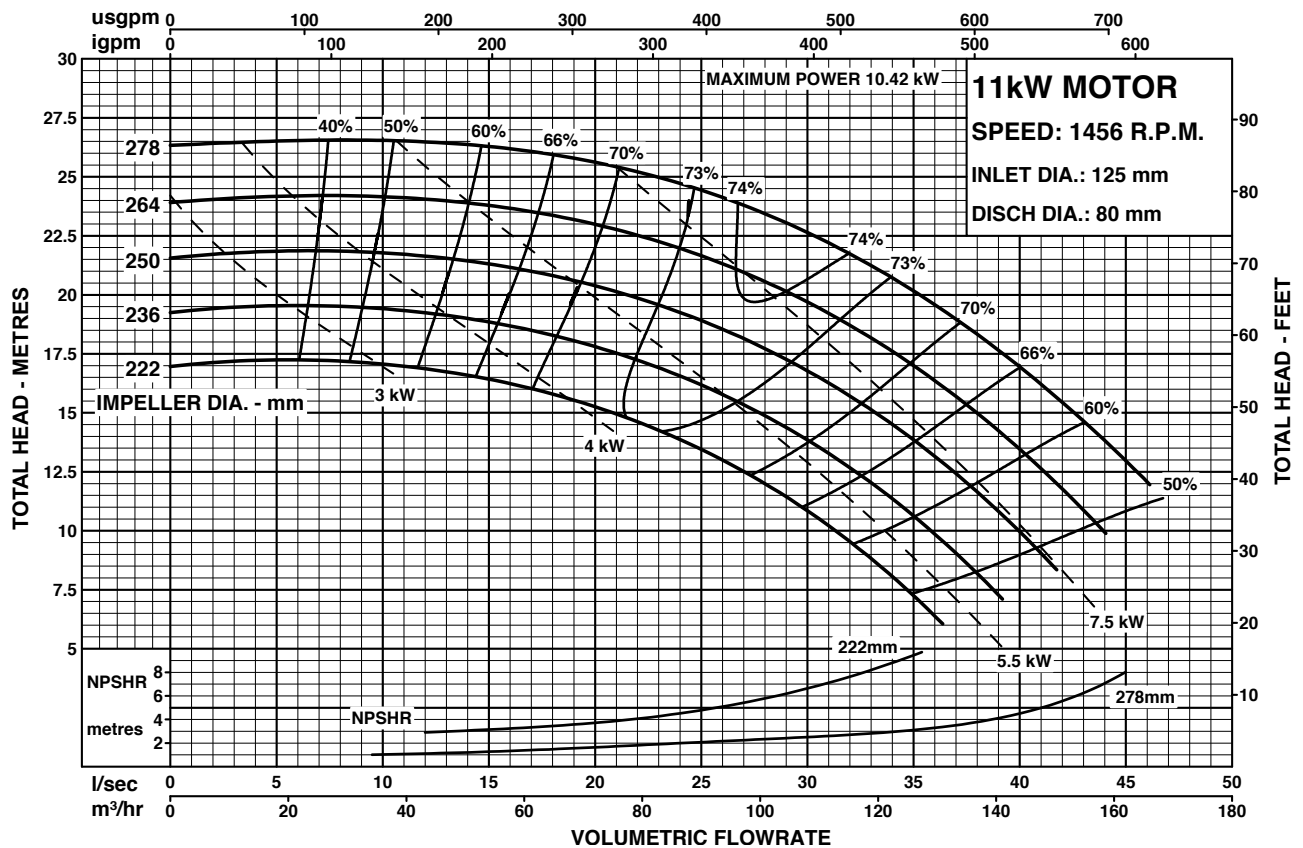

Performance to AS2417 Grade 2 for clean, cold water only.

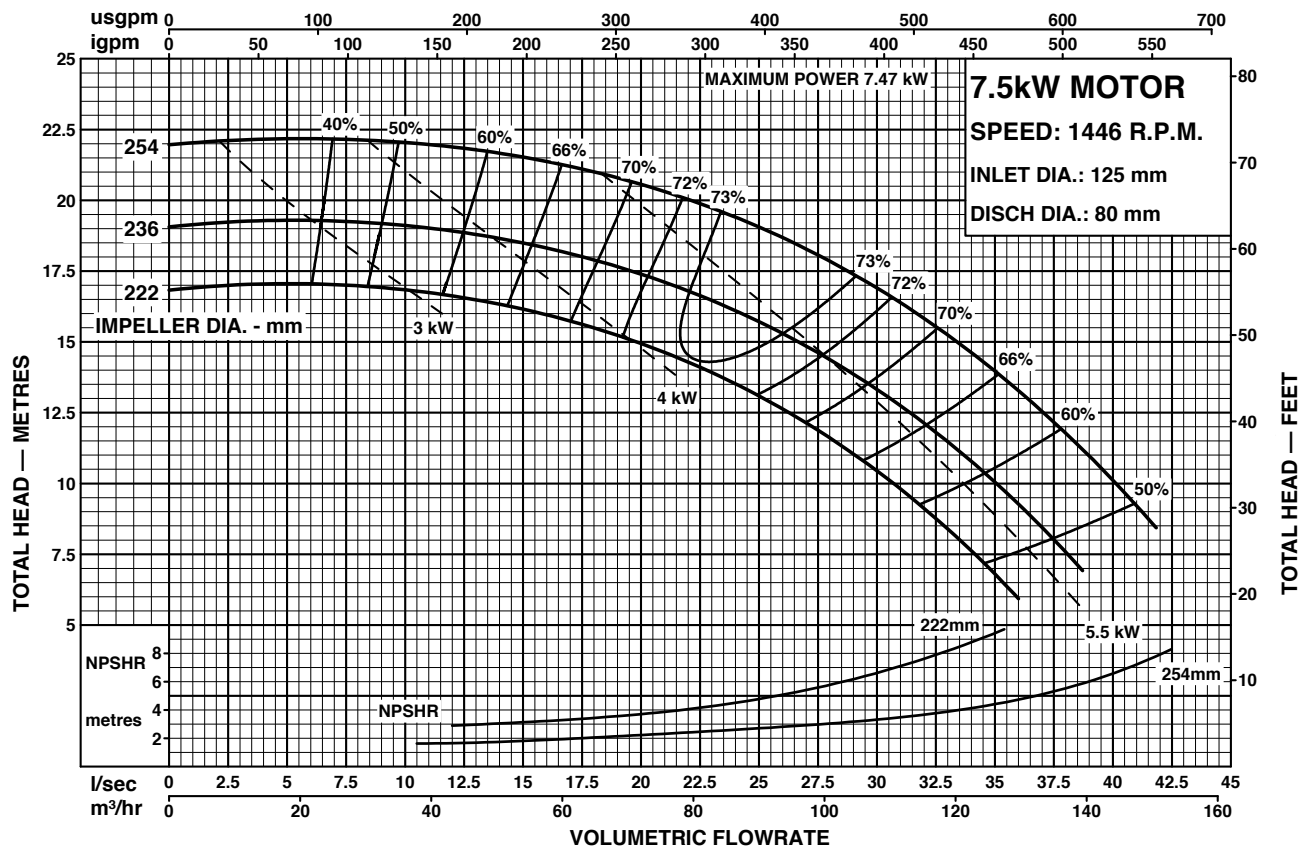

Performance to AS2417 Grade 2 for clean, cold water only.





# PENTAIR STARLINE

MOTORPUMPS  
50Hz PERFORMANCE

MODEL  
**125x80-250**

CENTRIFUGAL PUMP PERFORMANCE DATA

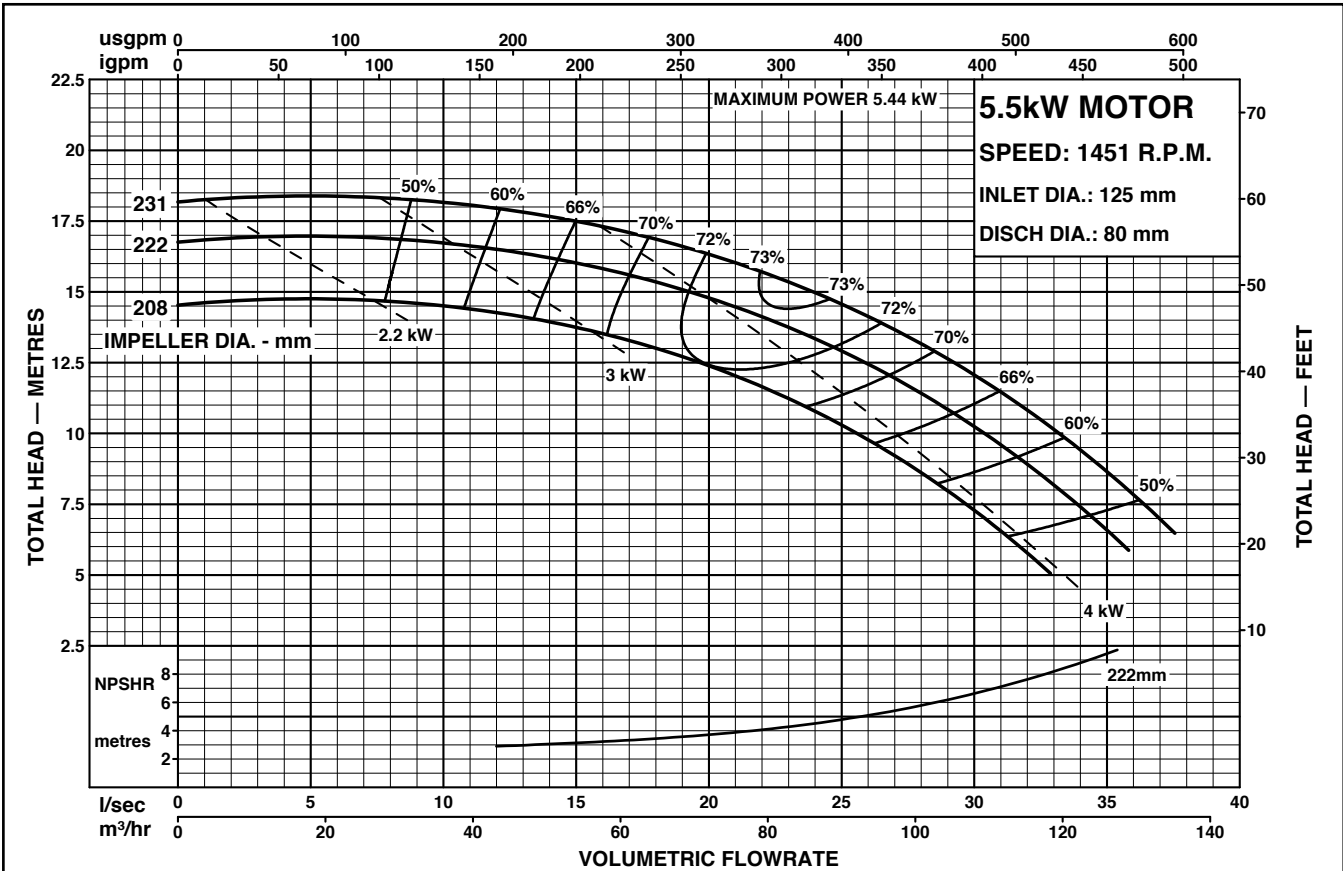

Performance to AS2417 Grade 2 for clean, cold water only.





# PENTAIR STARLINE

MOTORPUMPS

50Hz PERFORMANCE

MODEL  
**125x80-250**

CENTRIFUGAL PUMP PERFORMANCE DATA

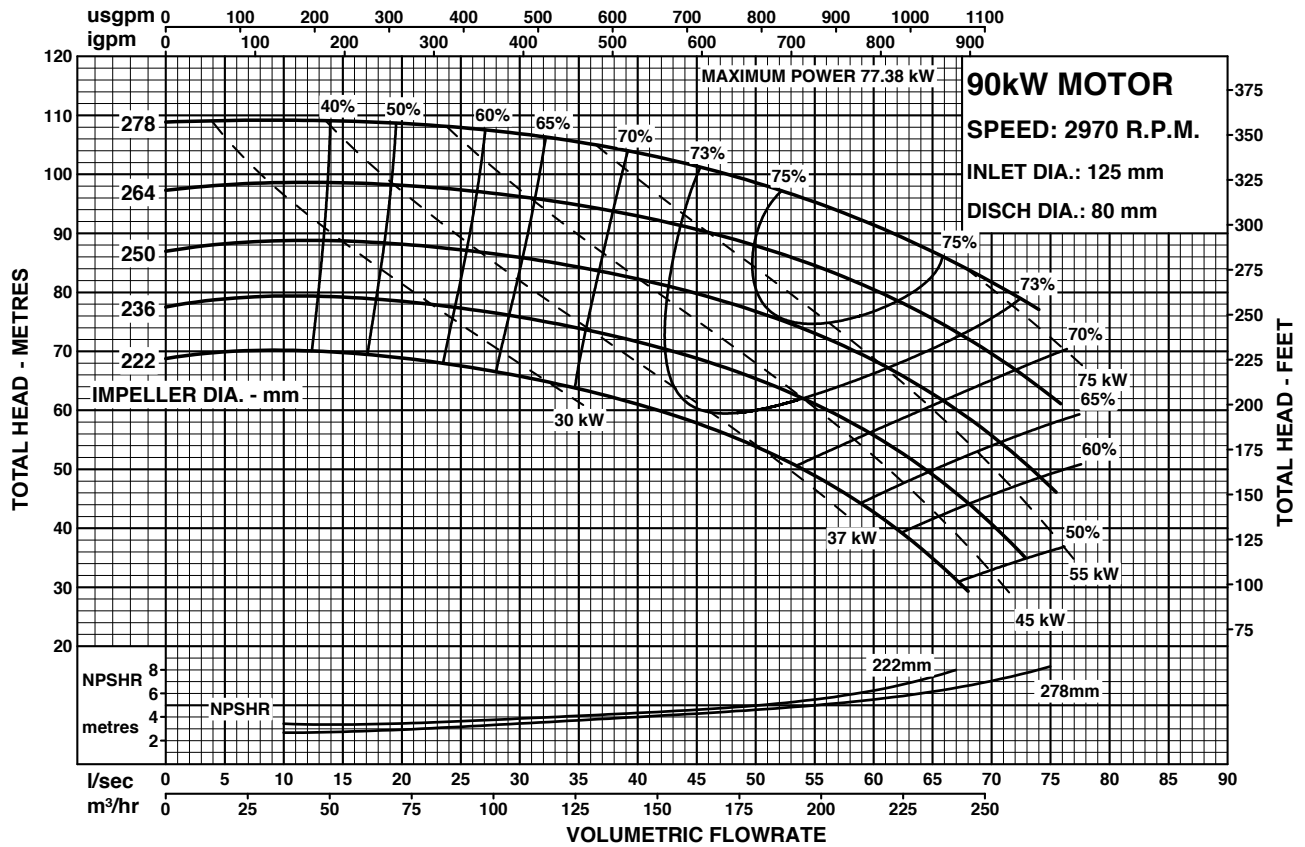

Performance to AS2417 Grade 2 for clean, cold water only.

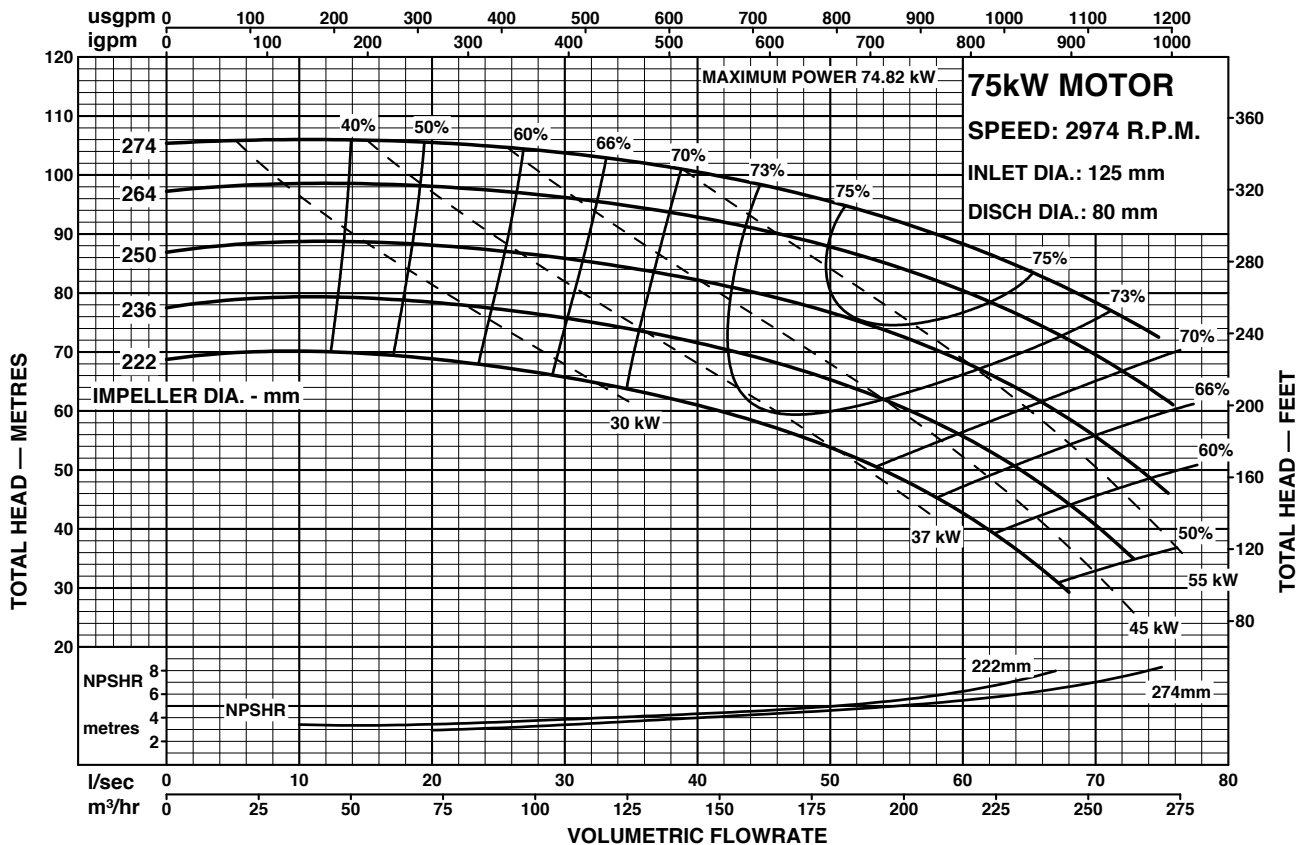

Performance to AS2417 Grade 2 for clean, cold water only.





# PENTAIR STARLINE

MOTORPUMPS  
50Hz PERFORMANCE

MODEL  
**125x80-250**

CENTRIFUGAL PUMP PERFORMANCE DATA

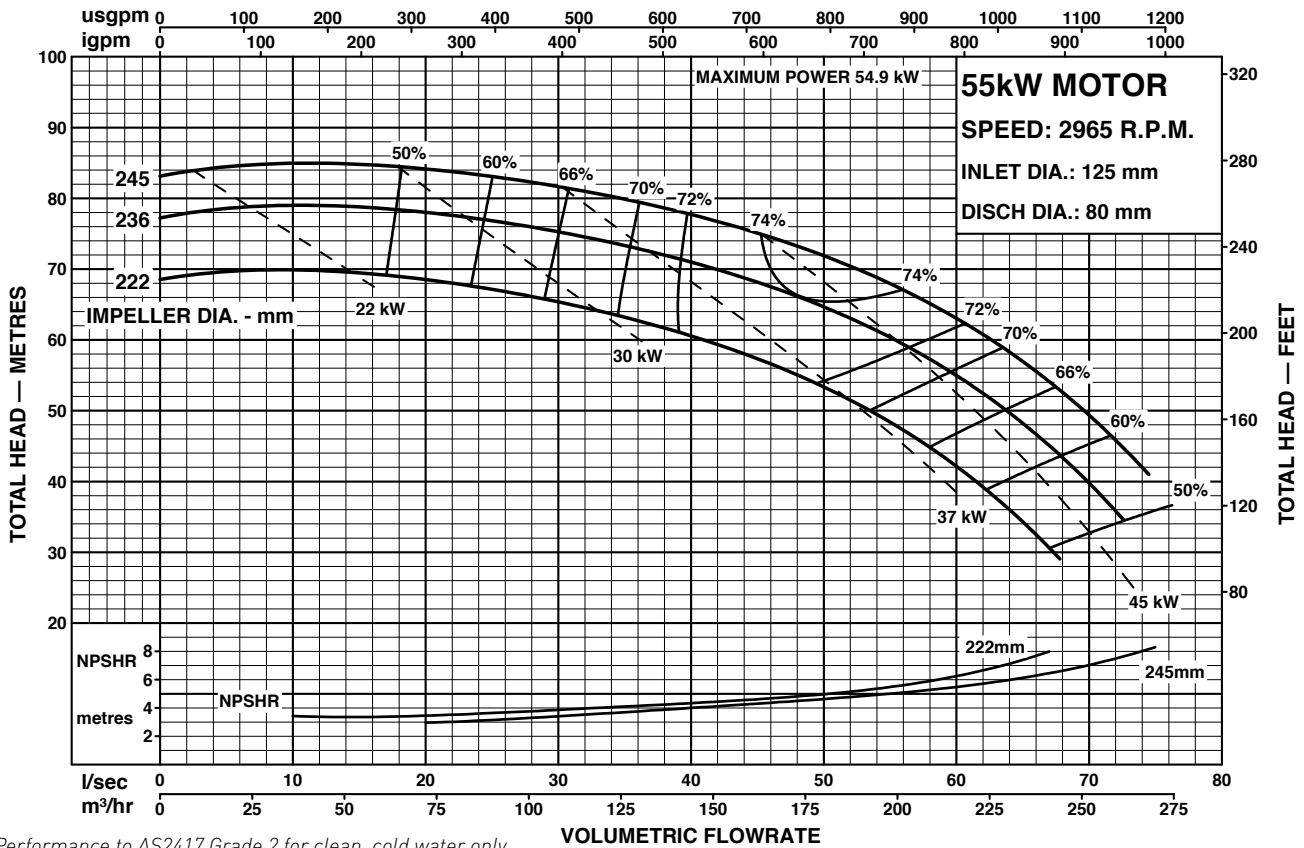

Performance to AS2417 Grade 2 for clean, cold water only.

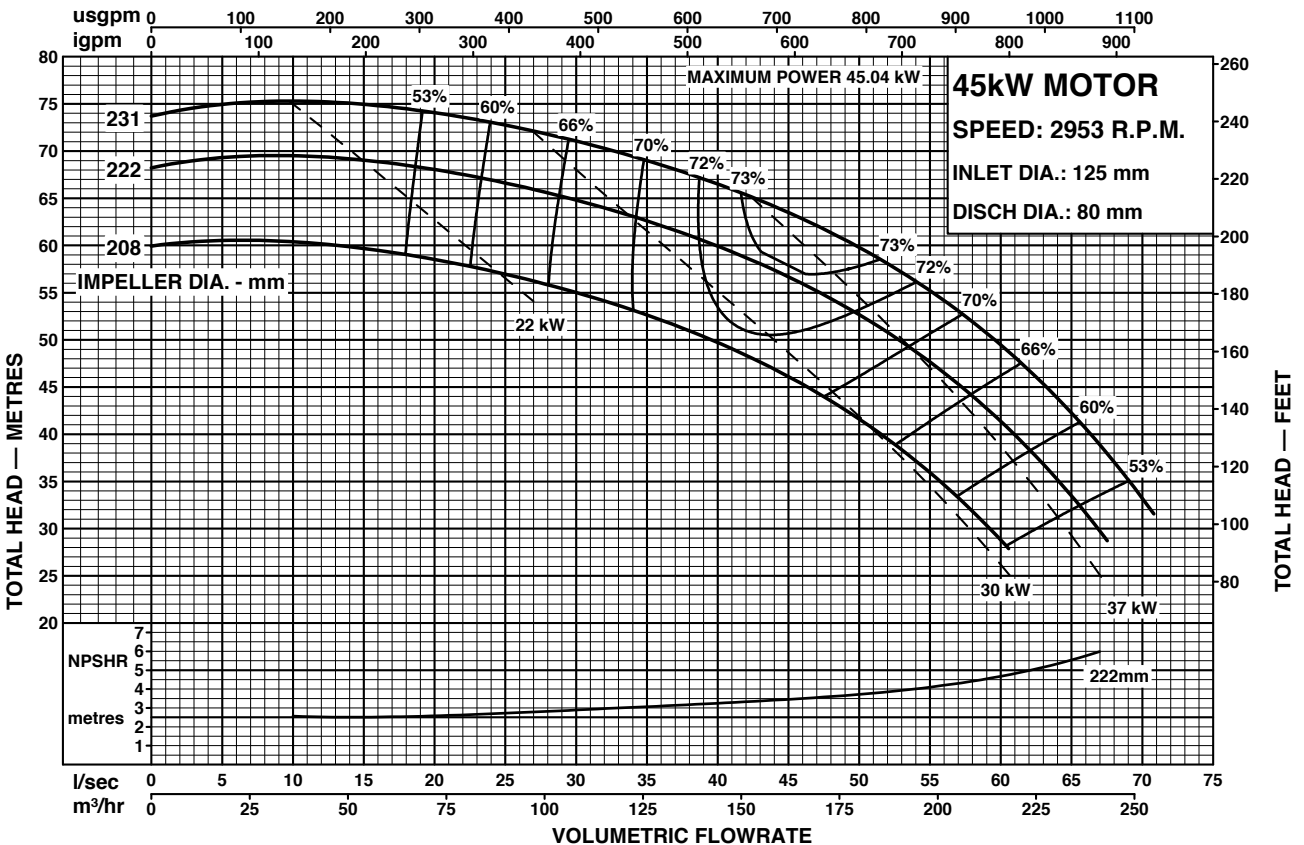

Performance to AS2417 Grade 2 for clean, cold water only.





# PENTAIR STARLINE

MOTORPUMPS

50Hz PERFORMANCE

MODEL  
**125x80-315**

CENTRIFUGAL PUMP PERFORMANCE DATA

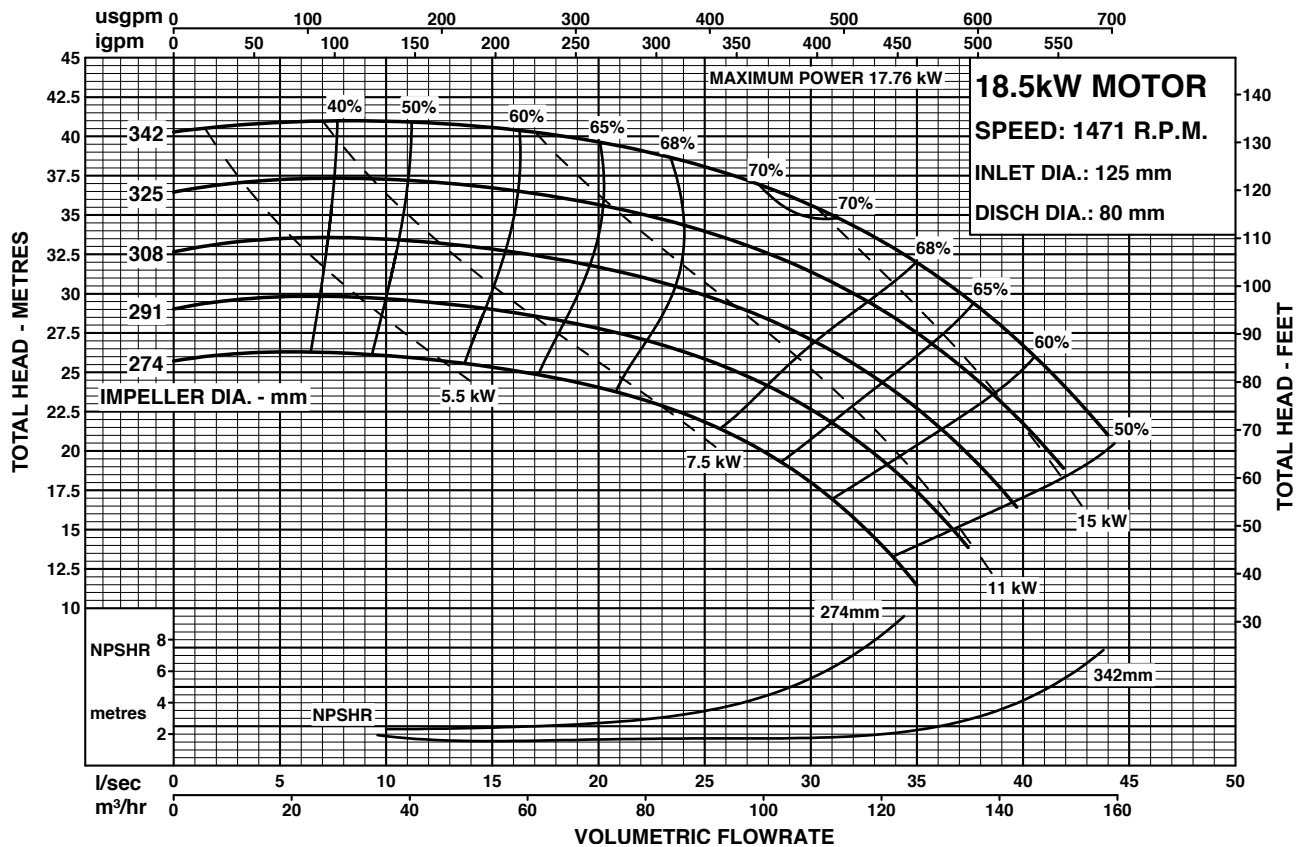

Performance to AS2417 Grade 2 for clean, cold water only.

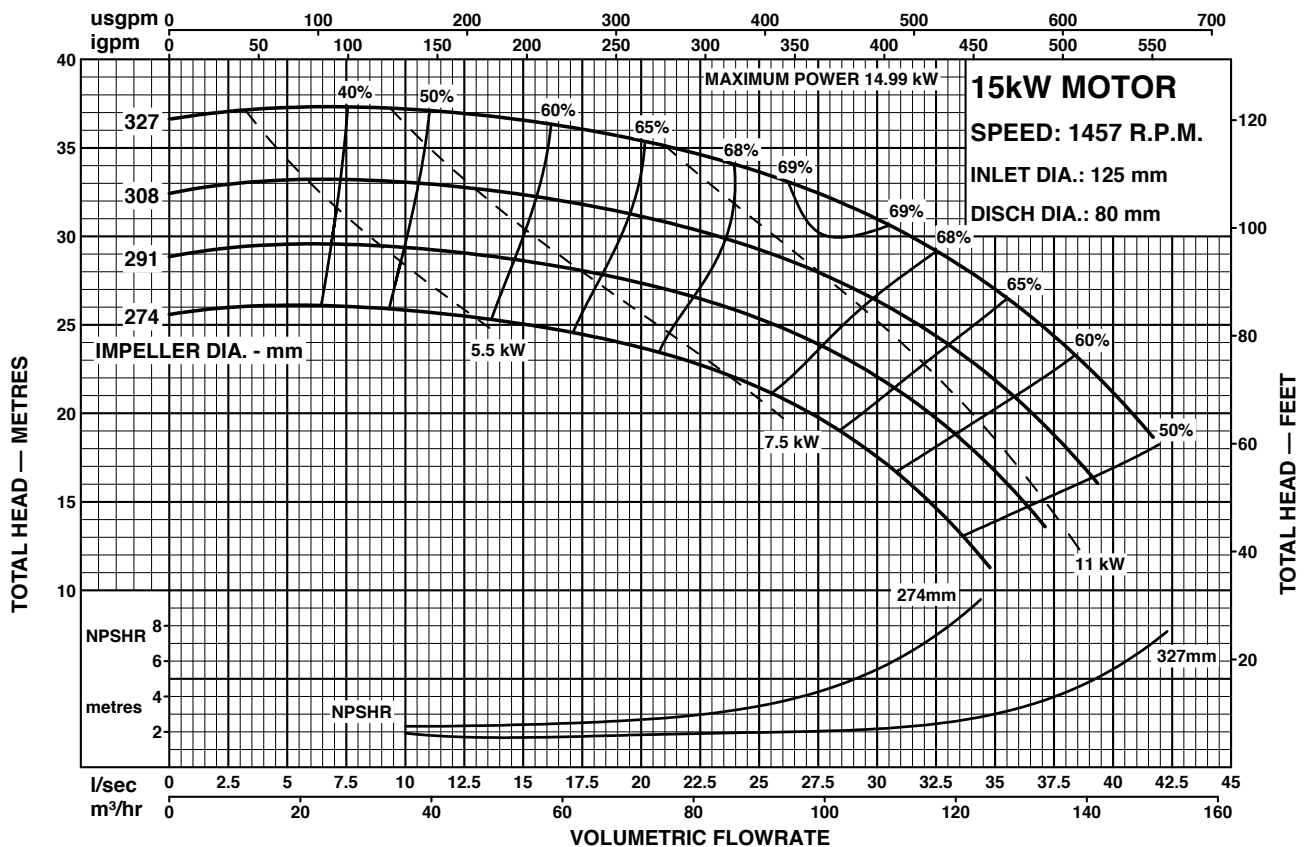

Performance to AS2417 Grade 2 for clean, cold water only.





# PENTAIR STARLINE

MOTORPUMPS  
50Hz PERFORMANCE

MODEL  
**125x80-315**

CENTRIFUGAL PUMP PERFORMANCE DATA

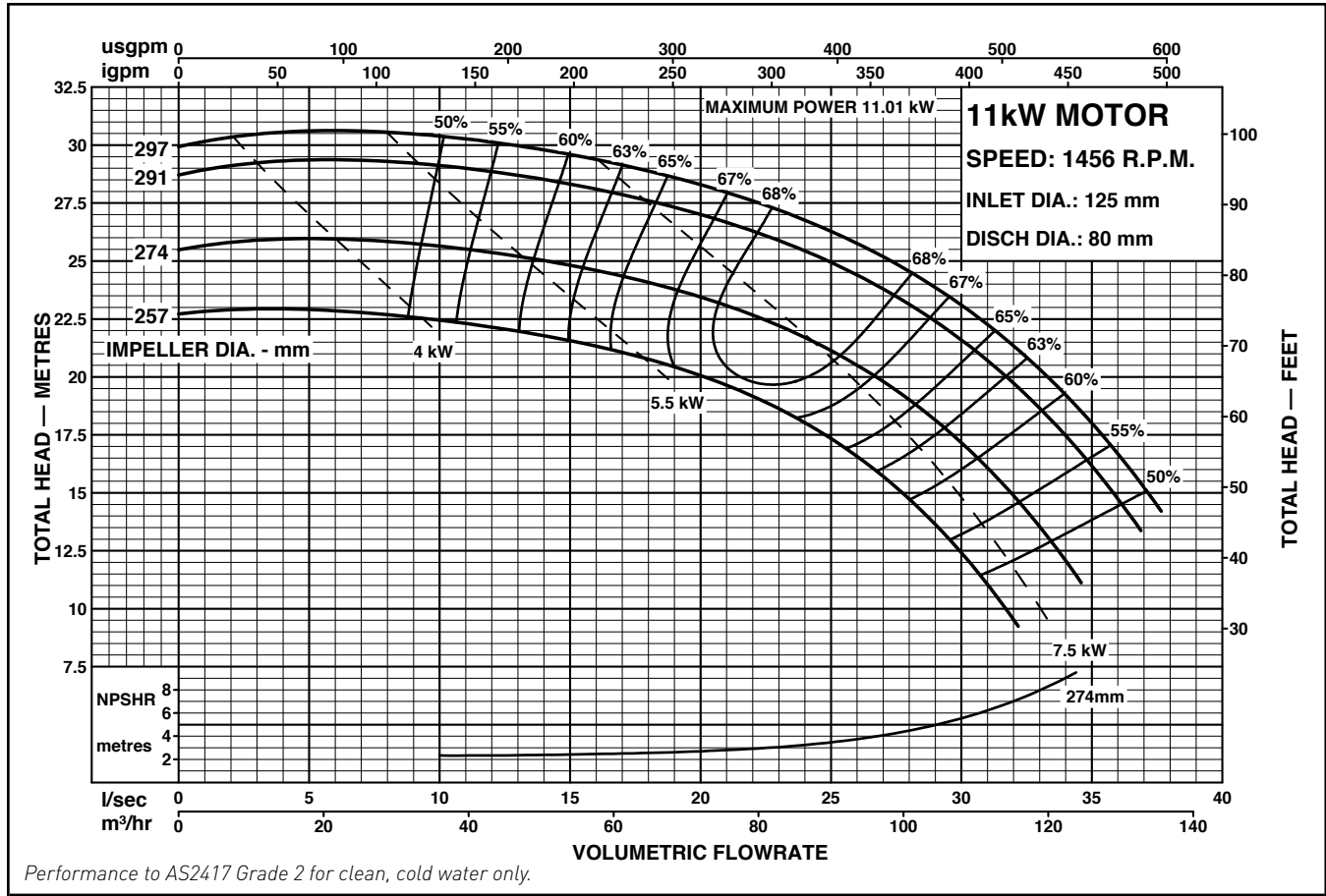



# PENTAIR STARLINE

MOTORPUMPS

50Hz PERFORMANCE

## MODEL 125x80-315

CENTRIFUGAL PUMP PERFORMANCE DATA

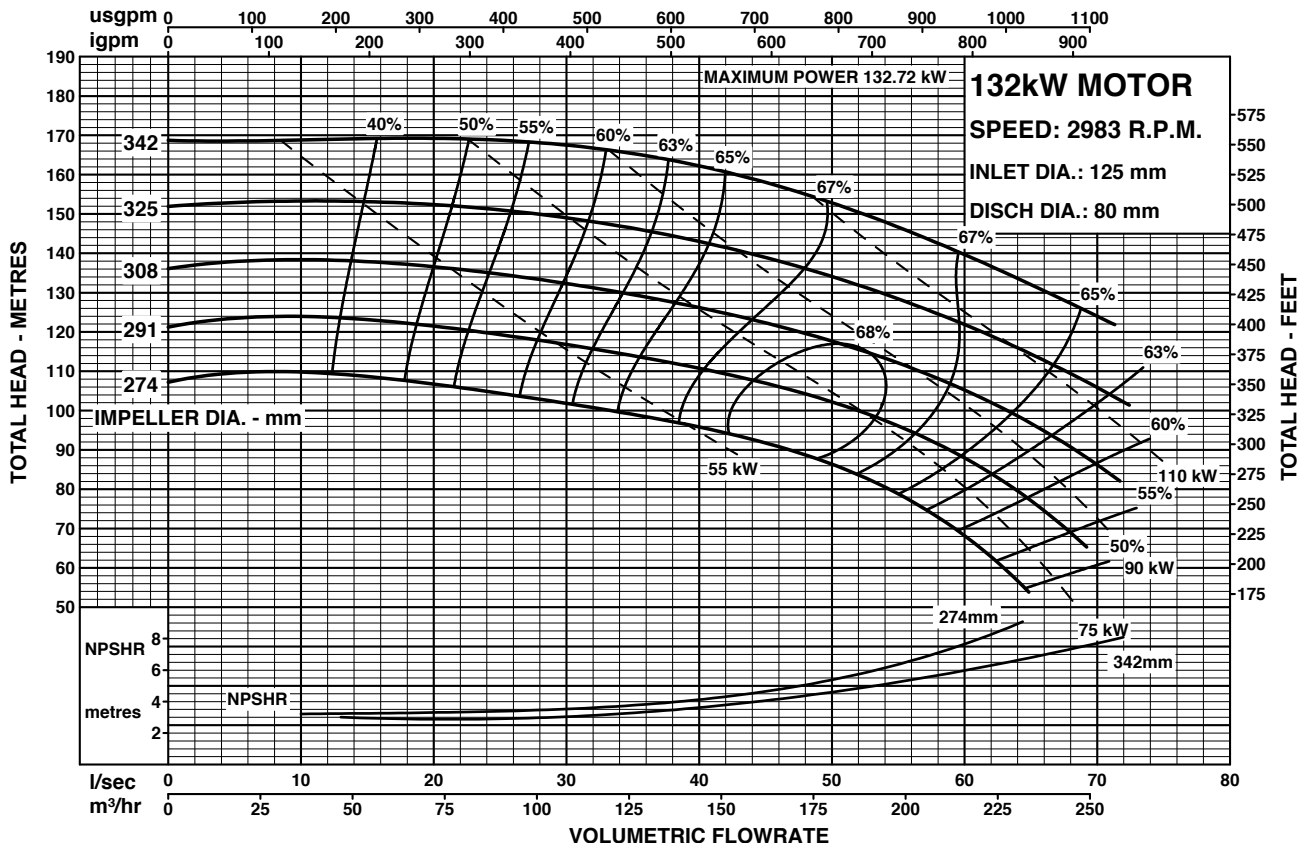

Performance to AS2417 Grade 2 for clean, cold water only.

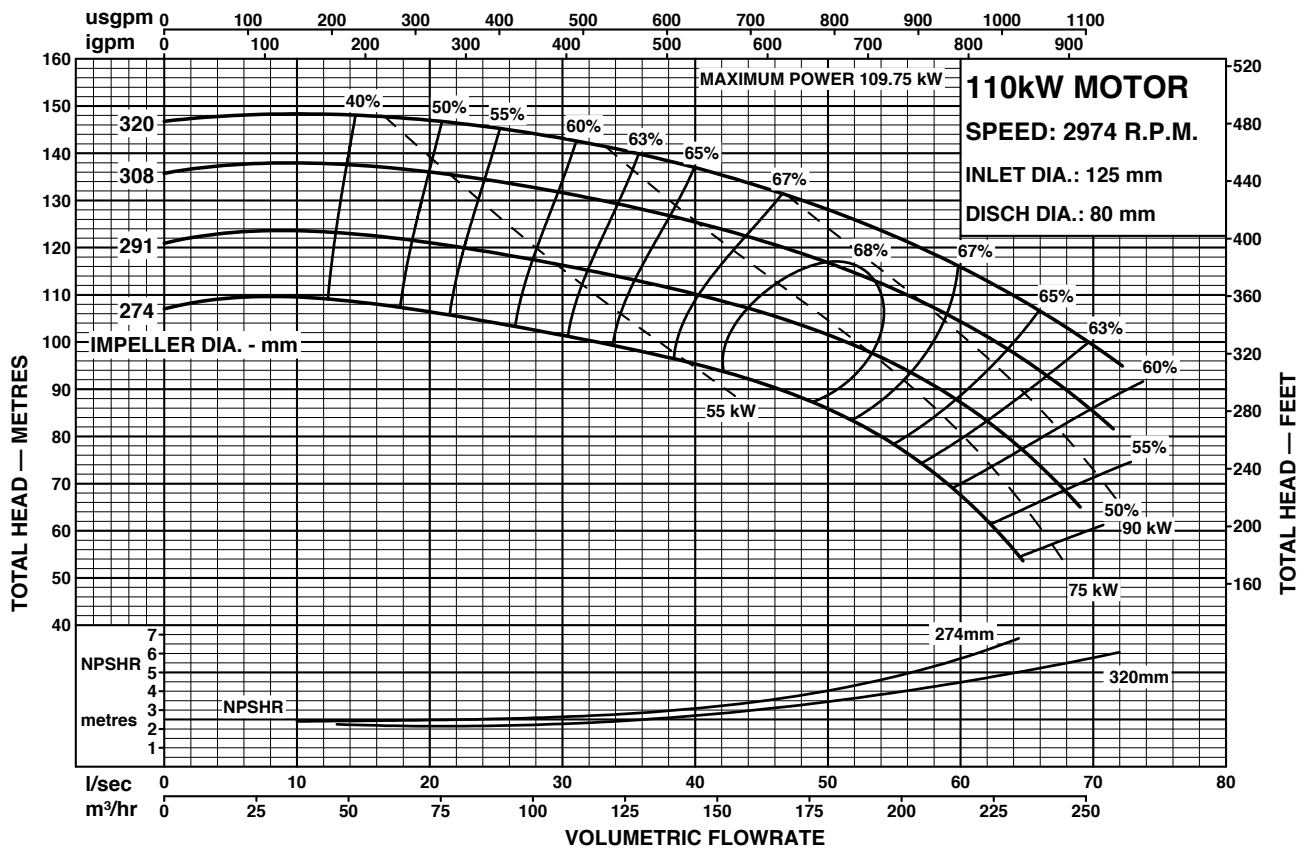

Performance to AS2417 Grade 2 for clean, cold water only.





# PENTAIR STARLINE

MOTORPUMPS  
50Hz PERFORMANCE

MODEL  
**125x80-315**

CENTRIFUGAL PUMP PERFORMANCE DATA

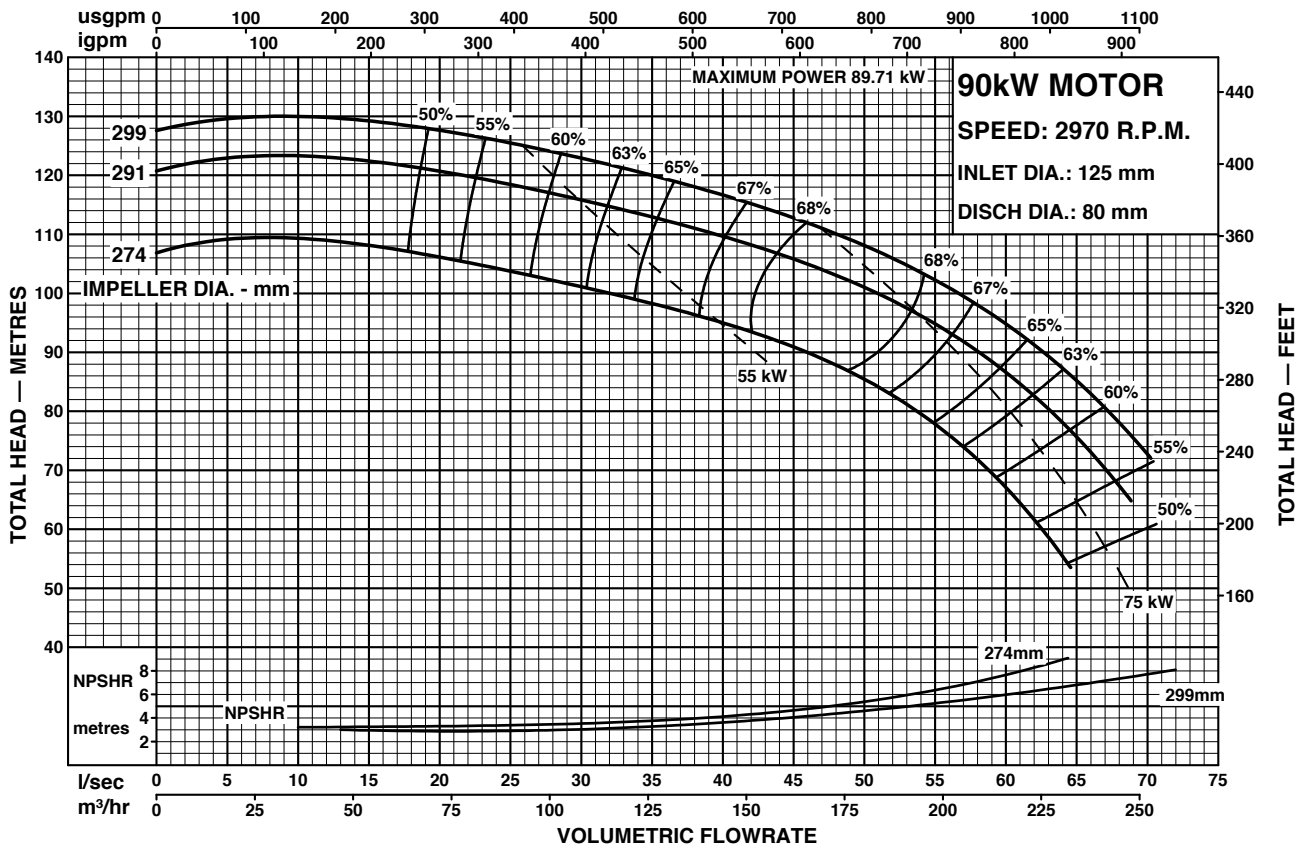

Performance to AS2417 Grade 2 for clean, cold water only.

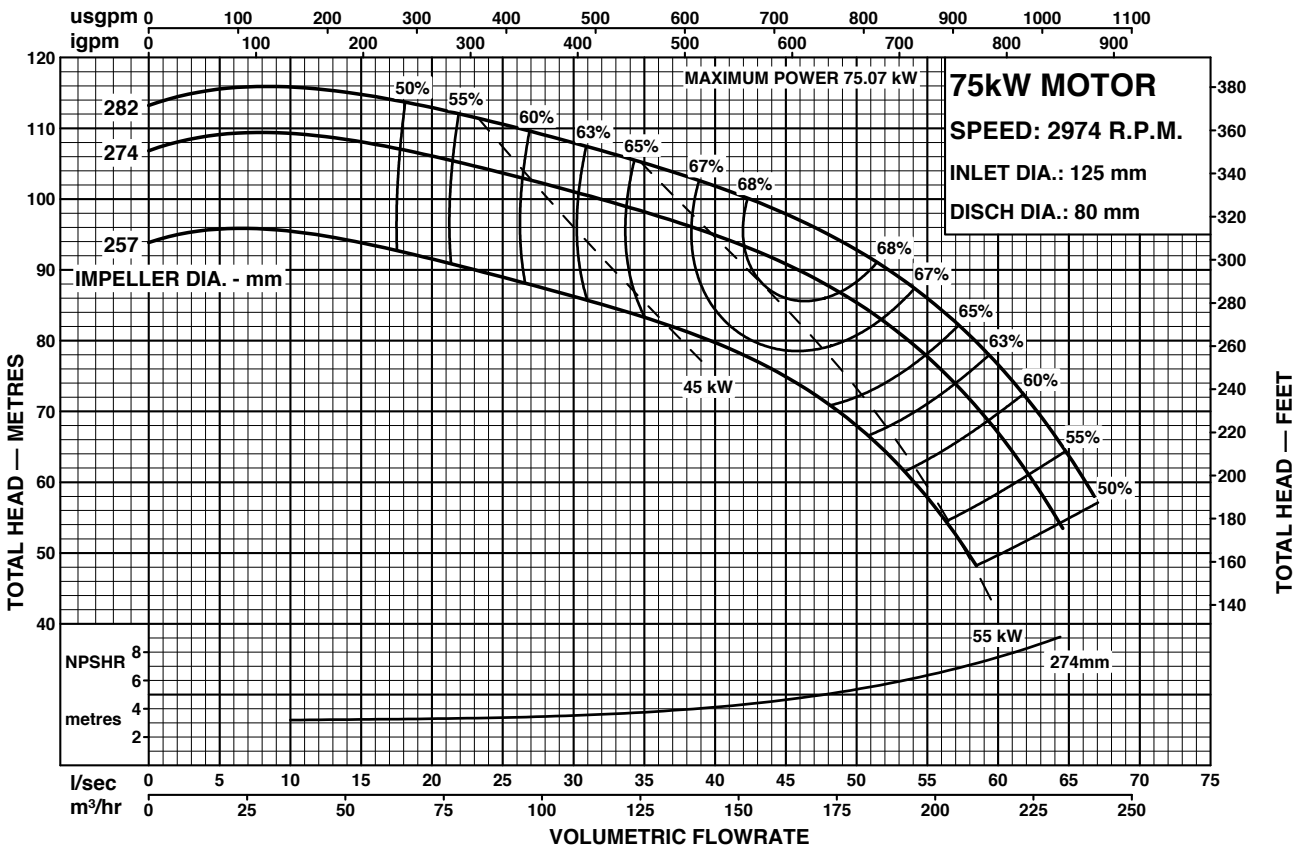

Performance to AS2417 Grade 2 for clean, cold water only.







# PENTAIR STARLINE

MOTORPUMPS

50Hz PERFORMANCE

## MODEL 125x80-400

CENTRIFUGAL PUMP PERFORMANCE DATA

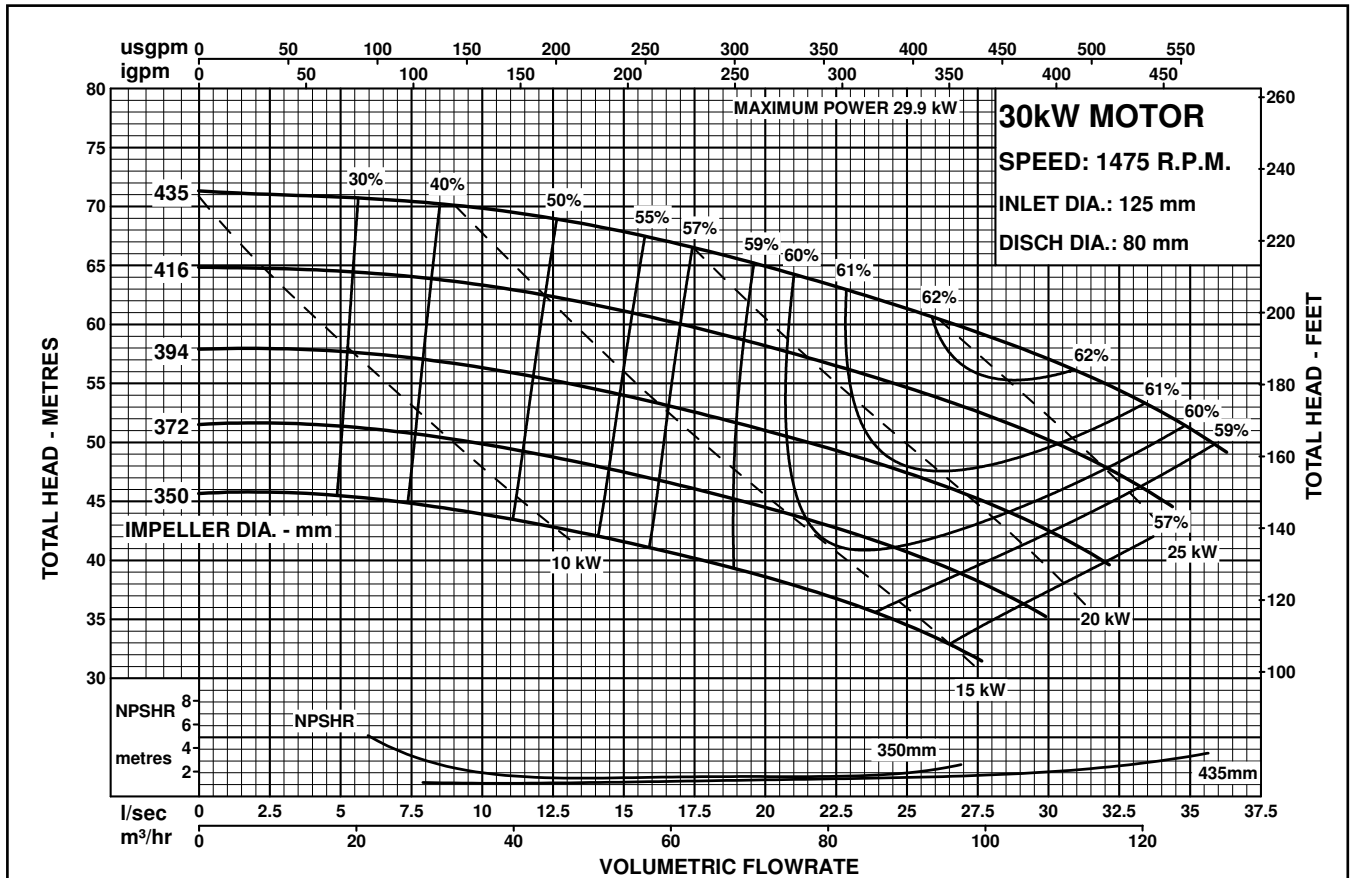

Performance to AS2417 Grade 2 for clean, cold water only.

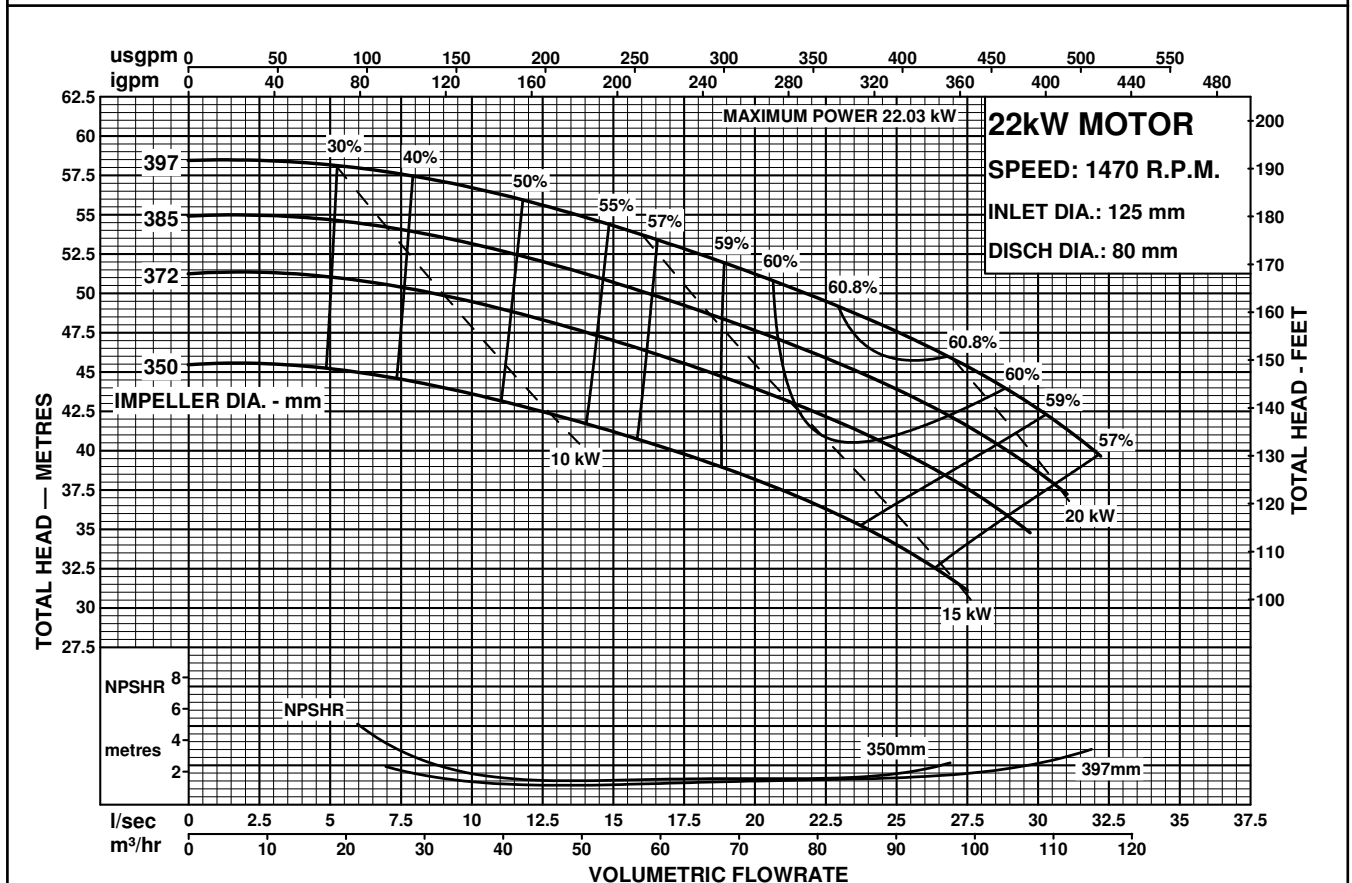

Performance to AS2417 Grade 2 for clean, cold water only.





# PENTAIR STARLINE

MOTORPUMPS  
50Hz PERFORMANCE

MODEL  
**125x80-400**

CENTRIFUGAL PUMP PERFORMANCE DATA

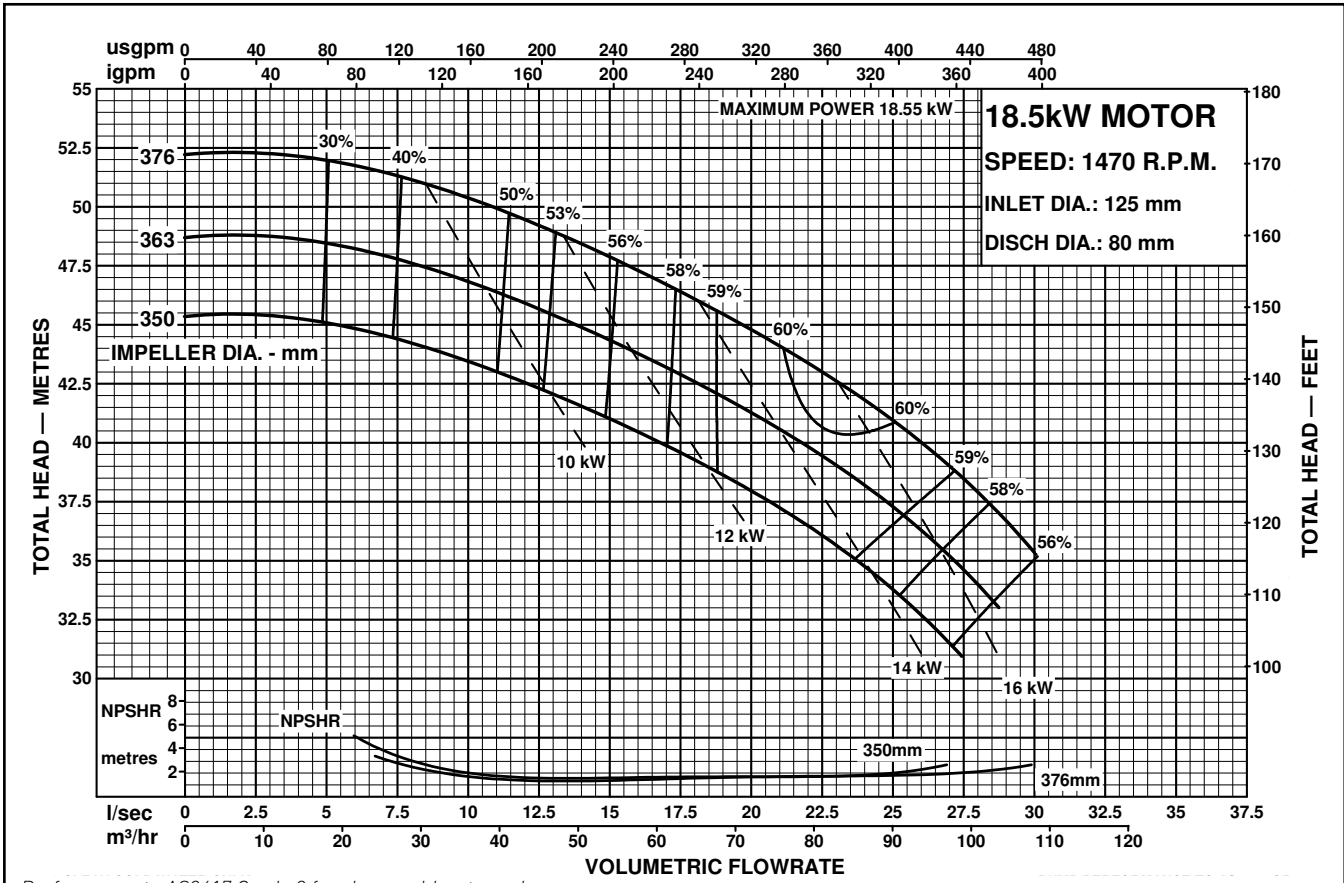

Performance to AS2417 Grade 2 for clean, cold water only.

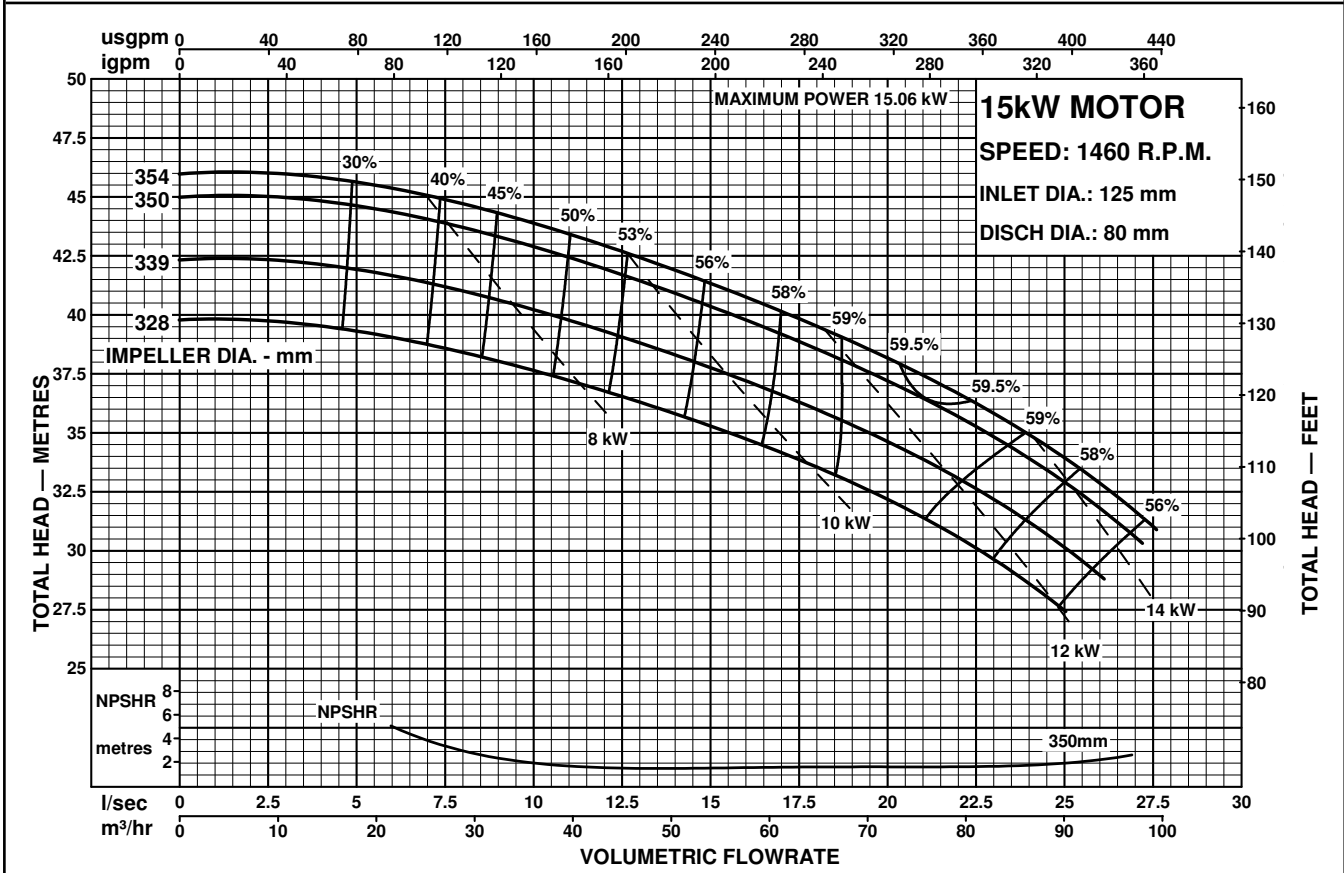

Performance to AS2417 Grade 2 for clean, cold water only.





# PENTAIR STARLINE

MOTORPUMPS

50Hz PERFORMANCE

## MODEL 125x100-200

CENTRIFUGAL PUMP PERFORMANCE DATA

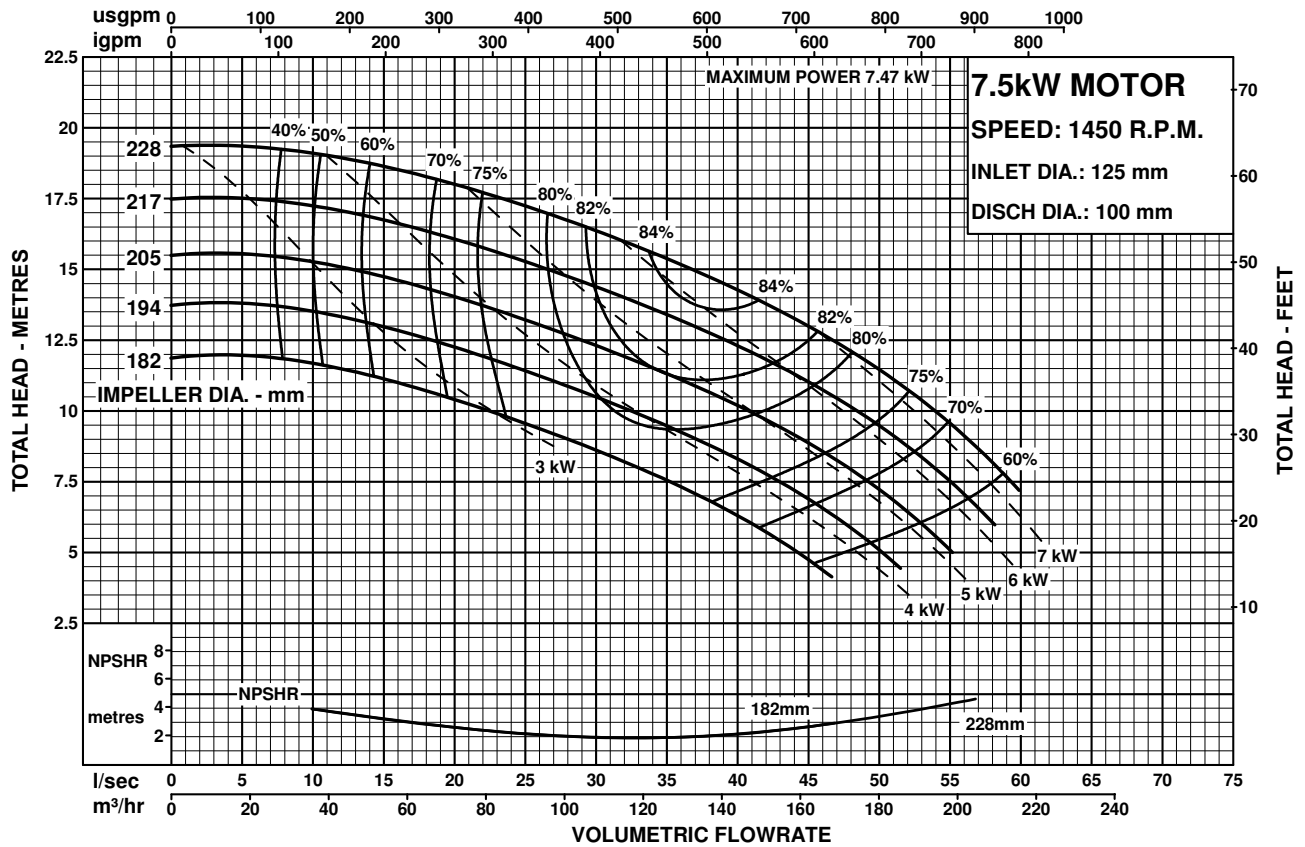

Performance to AS2417 Grade 2 for clean, cold water only.

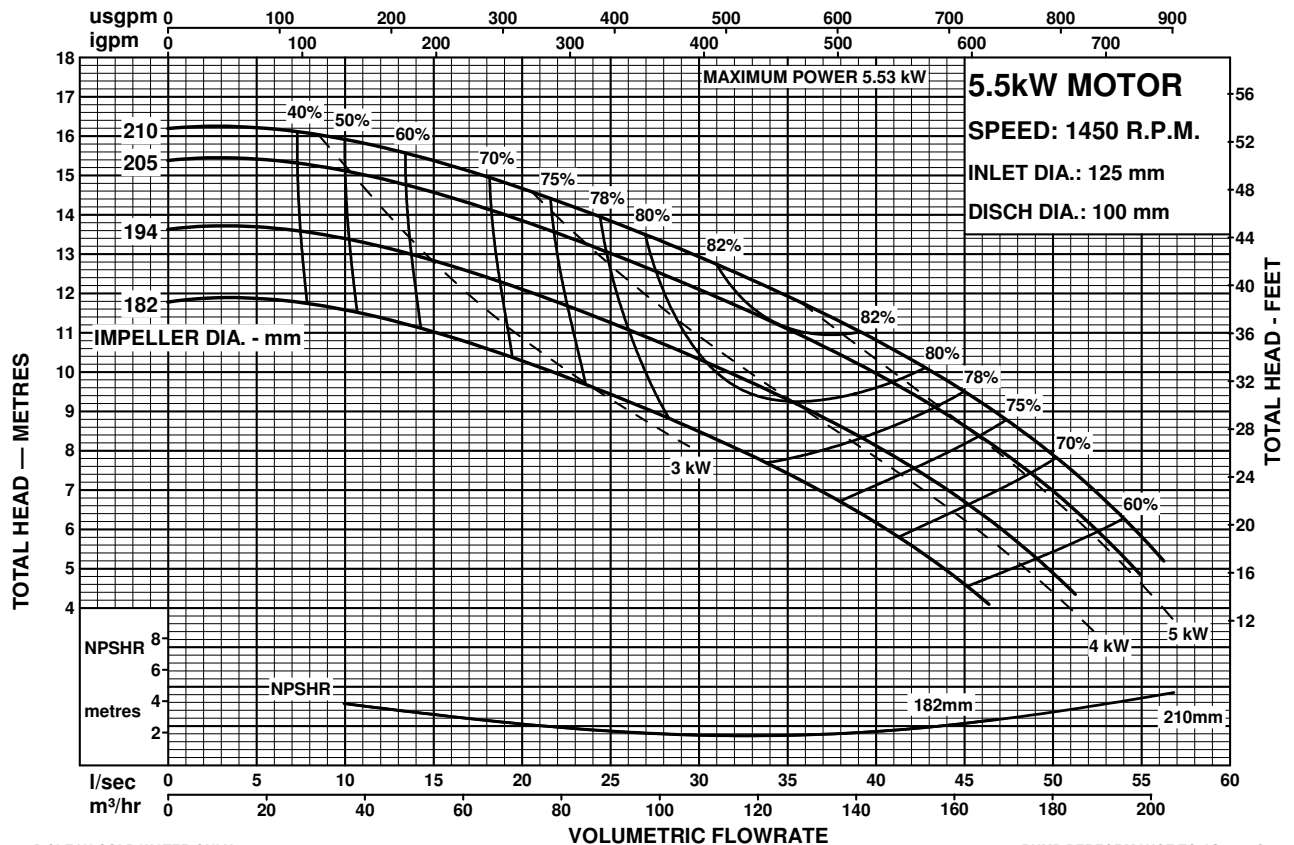

Performance to AS2417 Grade 2 for clean, cold water only.





# PENTAIR STARLINE

MOTORPUMPS  
50Hz PERFORMANCE

MODEL  
**125x100-200**

CENTRIFUGAL PUMP PERFORMANCE DATA

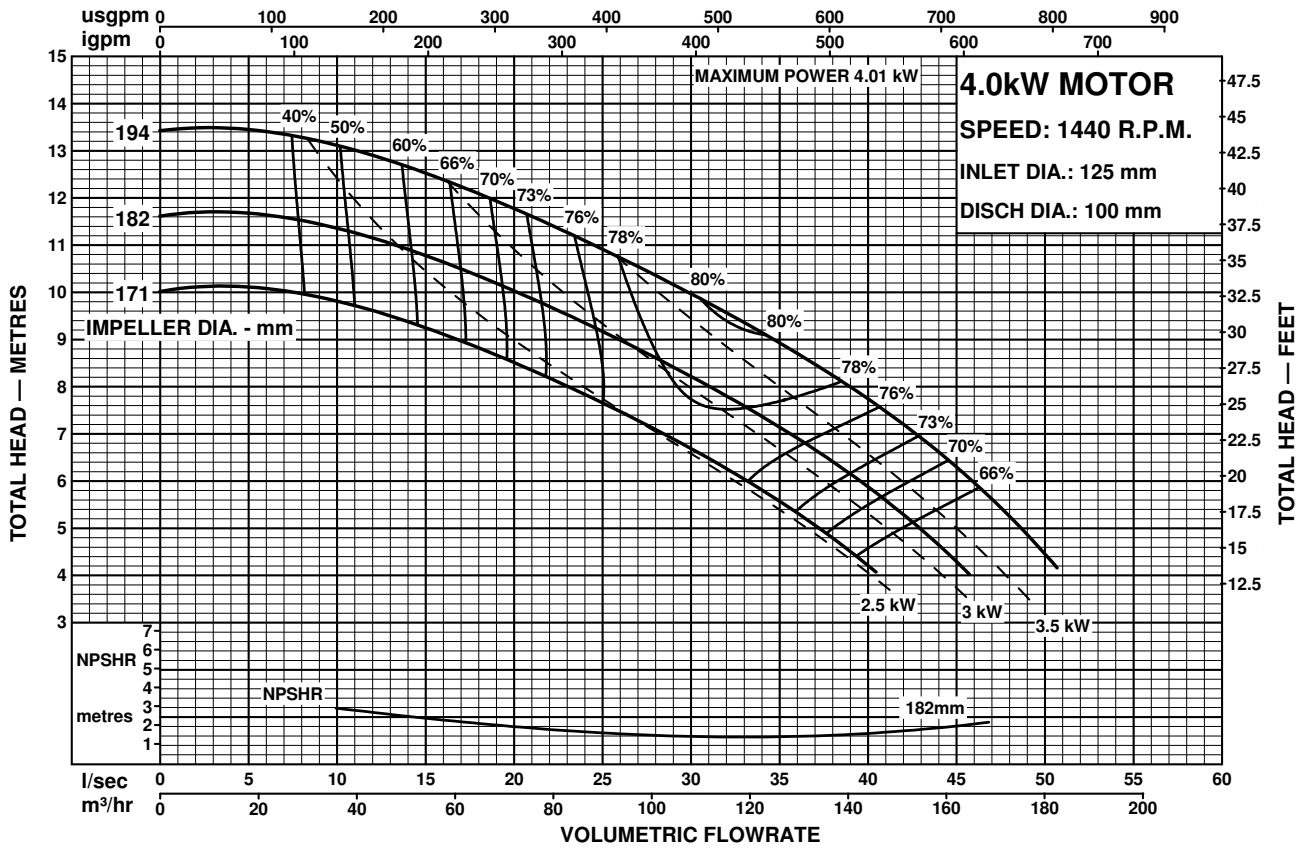

Performance to AS2417 Grade 2 for clean, cold water only.





# PENTAIR STARLINE

MOTORPUMPS

50Hz PERFORMANCE

## MODEL 125x100-200

CENTRIFUGAL PUMP PERFORMANCE DATA

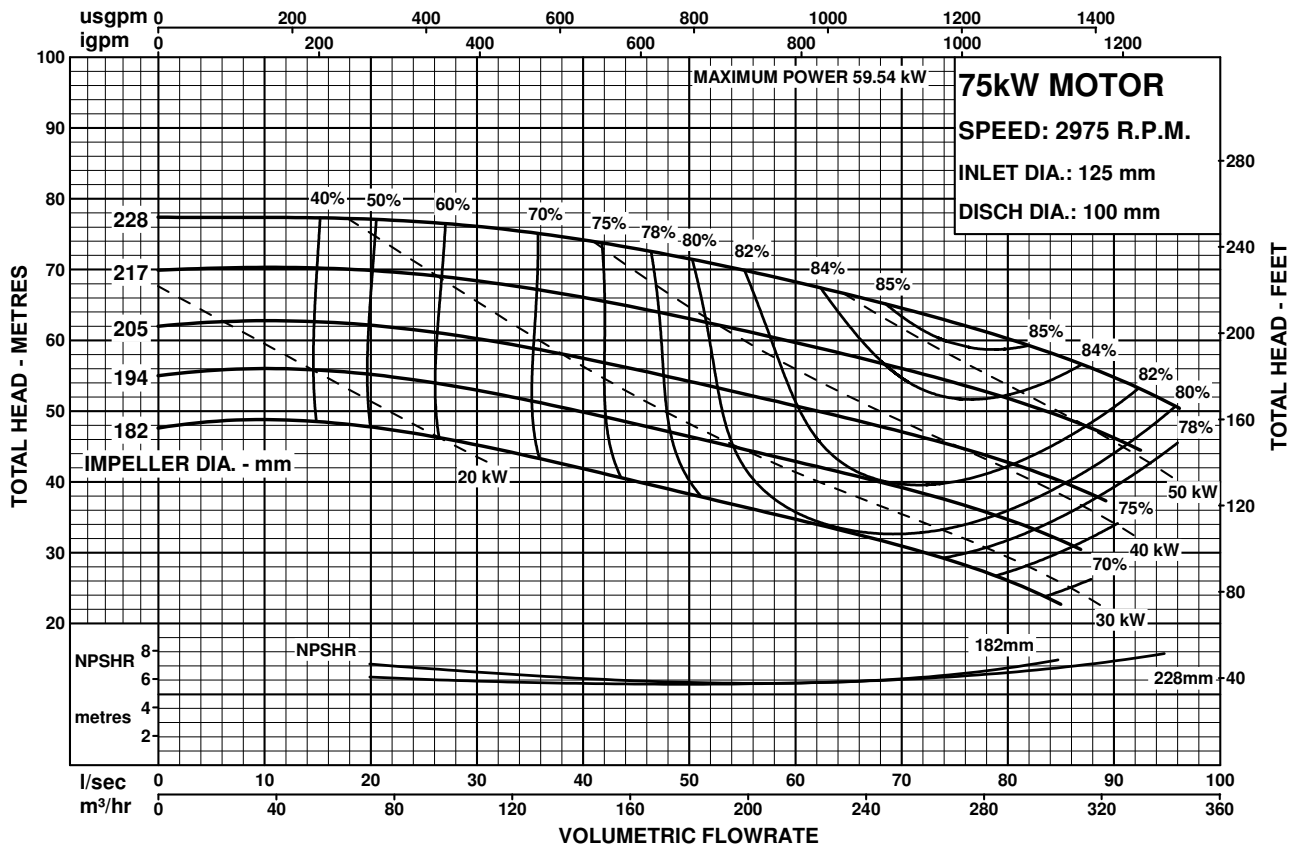

Performance to AS2417 Grade 2 for clean, cold water only.

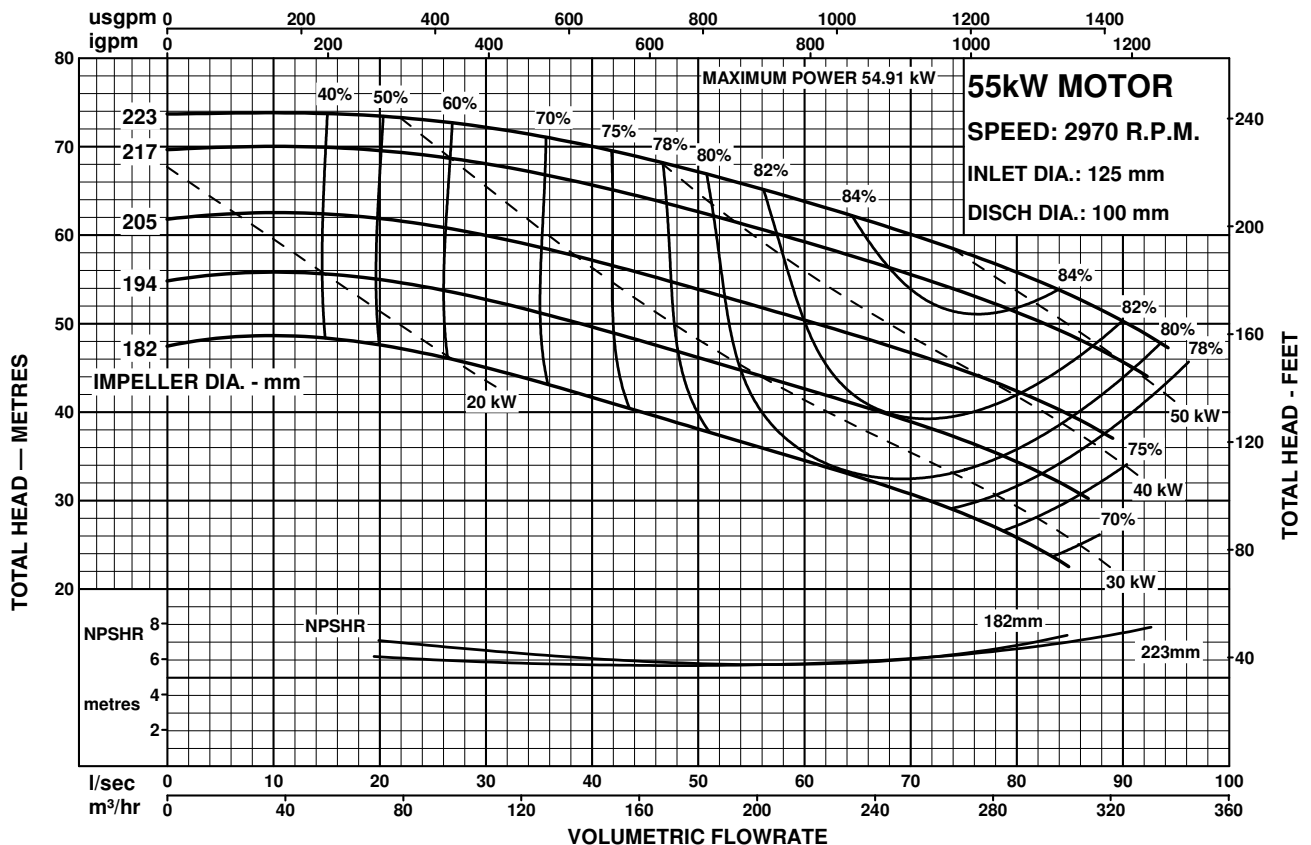

Performance to AS2417 Grade 2 for clean, cold water only.





# PENTAIR STARLINE

MOTORPUMPS  
50Hz PERFORMANCE

MODEL  
**125x100-200**

CENTRIFUGAL PUMP PERFORMANCE DATA

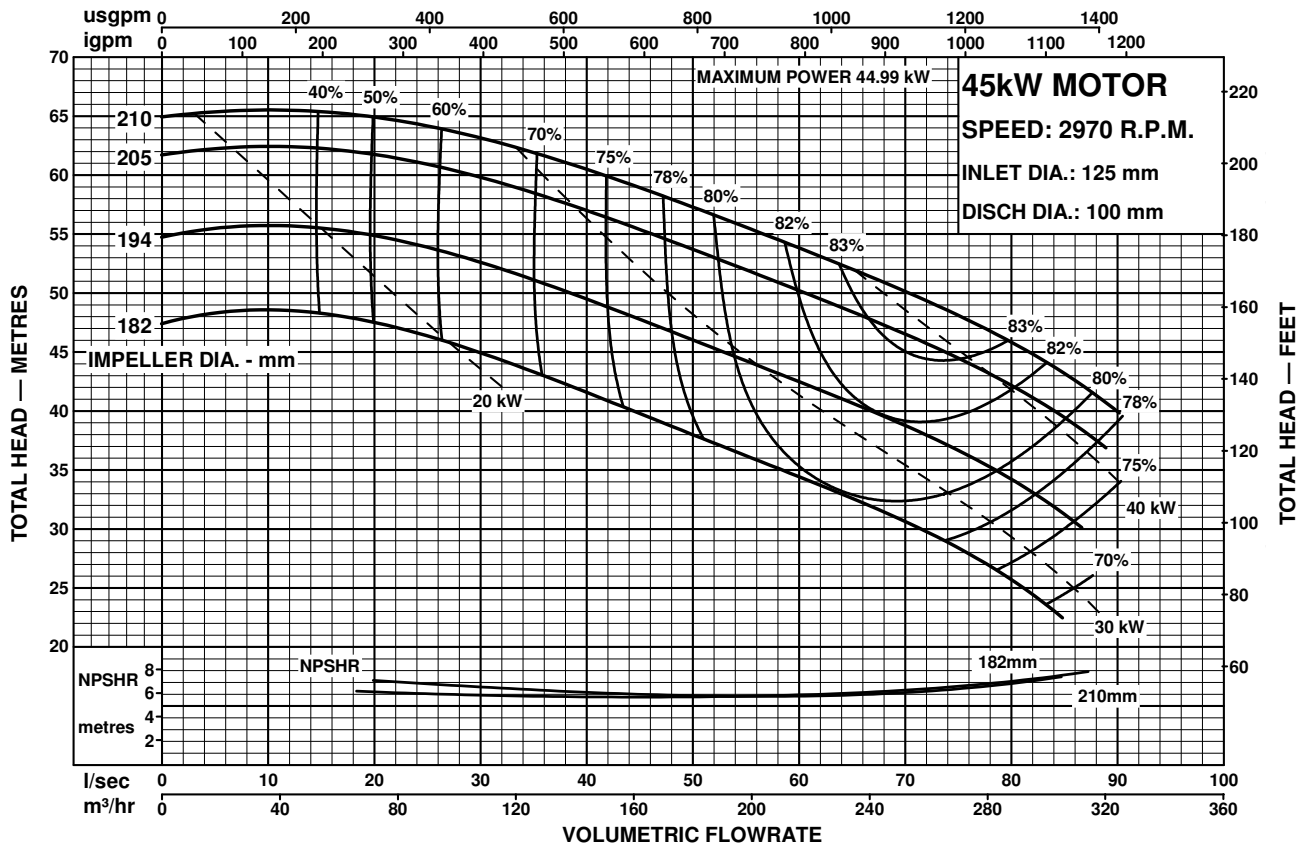

Performance to AS2417 Grade 2 for clean, cold water only.

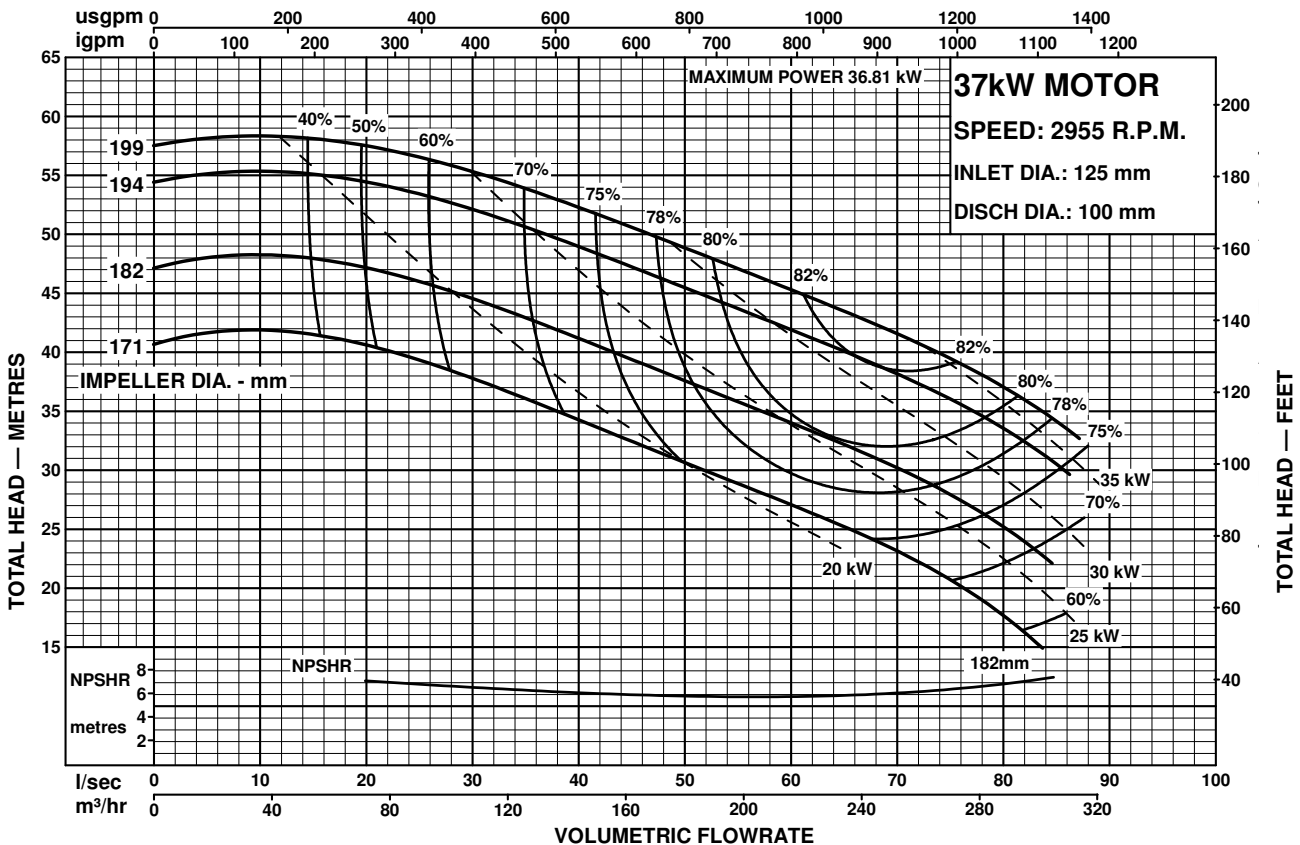

Performance to AS2417 Grade 2 for clean, cold water only.





# PENTAIR STARLINE

MOTORPUMPS  
50Hz PERFORMANCE

MODEL  
**125x100-200**

CENTRIFUGAL PUMP PERFORMANCE DATA

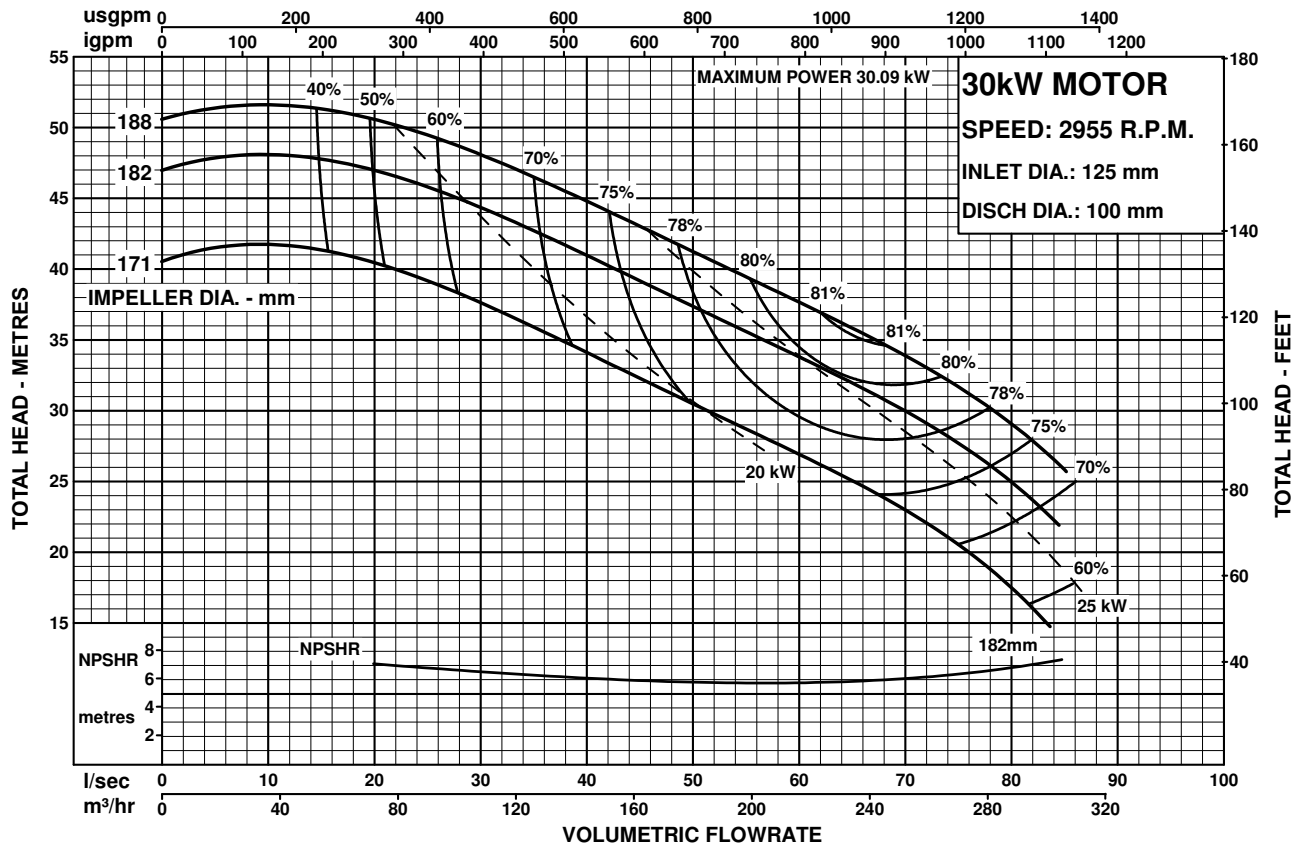

Performance to AS2417 Grade 2 for clean, cold water only.





# PENTAIR STARLINE

MOTORPUMPS  
50Hz PERFORMANCE

MODEL  
**125x100-250**

CENTRIFUGAL PUMP PERFORMANCE DATA

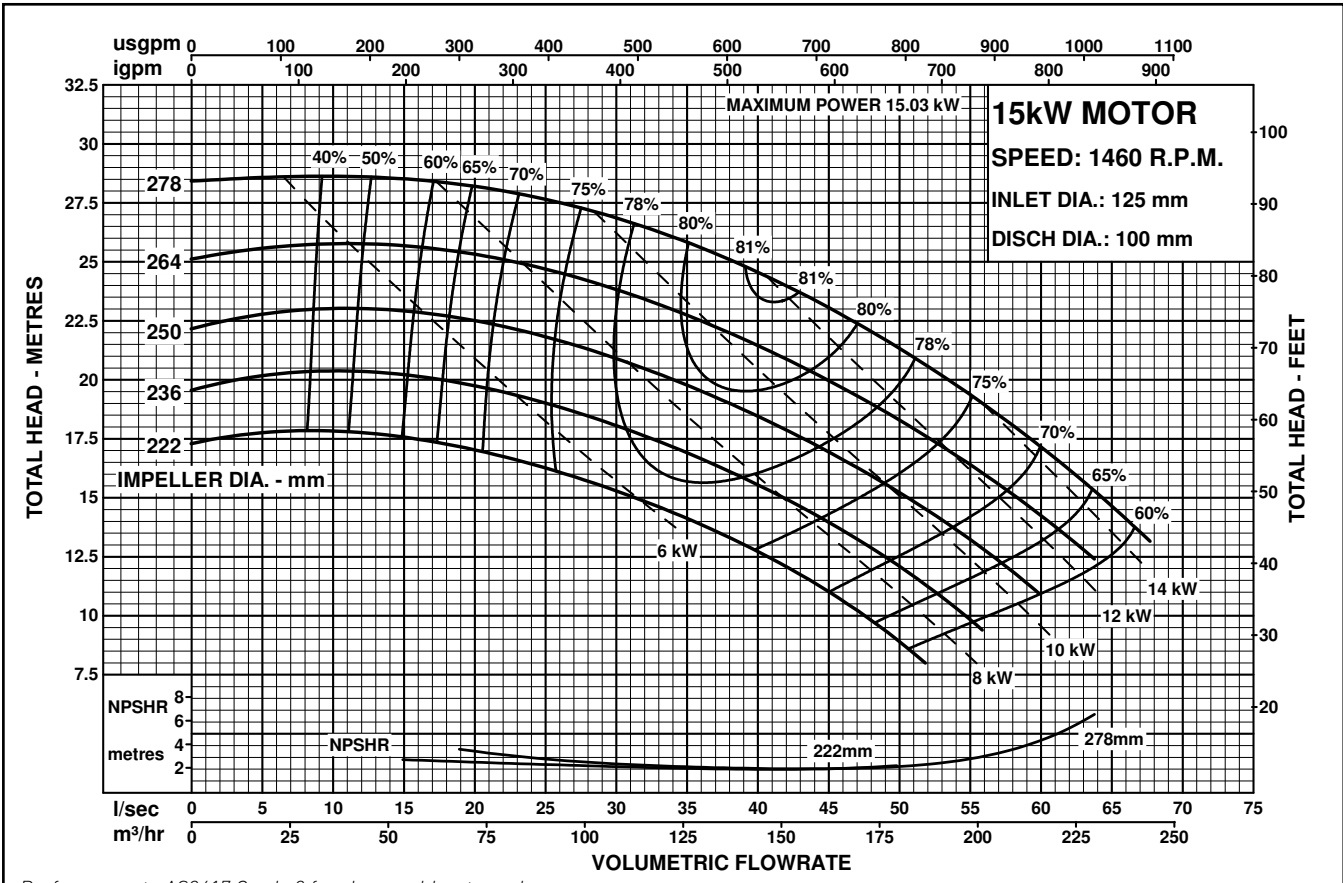

Performance to AS2417 Grade 2 for clean, cold water only.

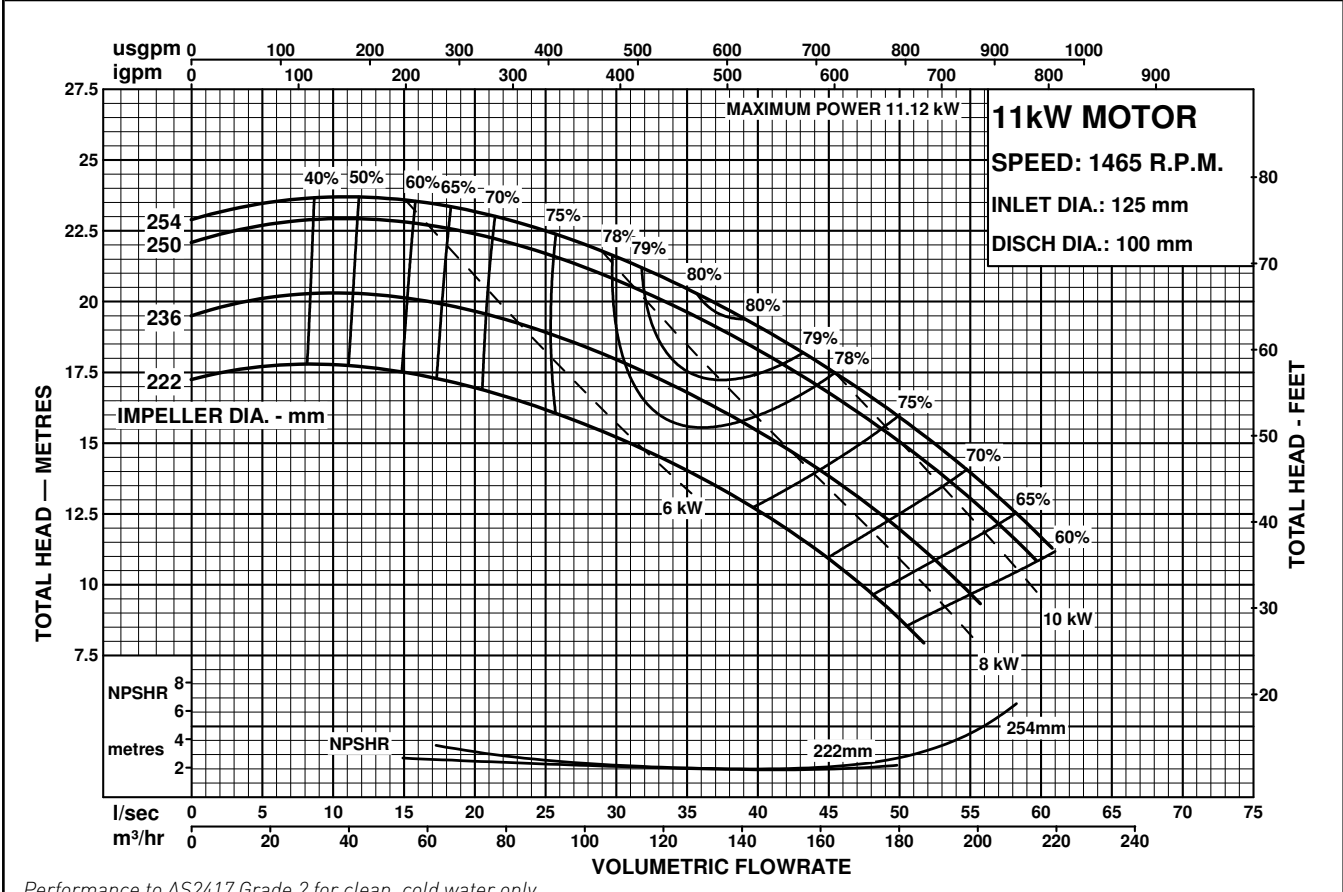

Performance to AS2417 Grade 2 for clean, cold water only.







# PENTAIR STARLINE

MOTORPUMPS  
50Hz PERFORMANCE

MODEL  
**125x100-250**

CENTRIFUGAL PUMP PERFORMANCE DATA

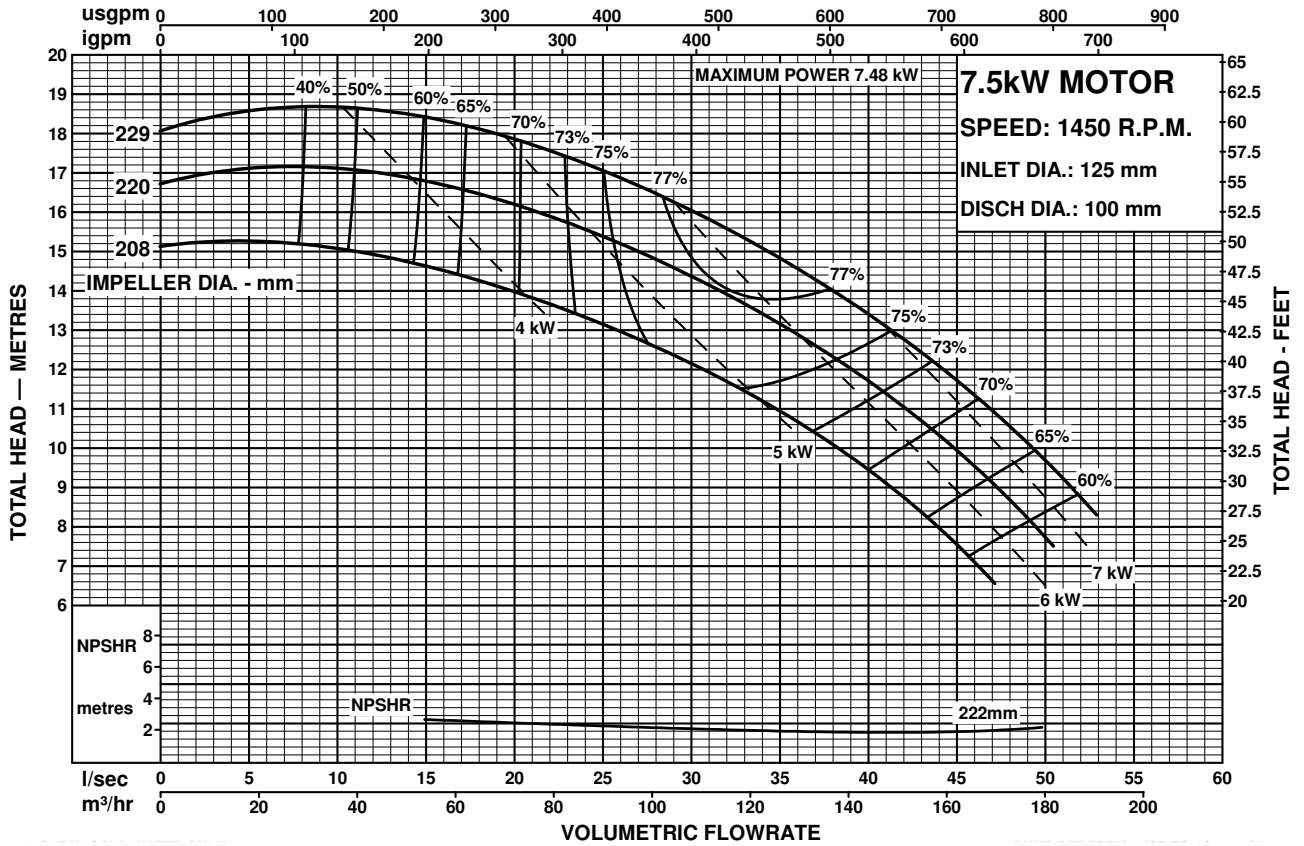

Performance to AS2417 Grade 2 for clean, cold water only.





# PENTAIR STARLINE

MOTORPUMPS  
50Hz PERFORMANCE

MODEL  
**125x100-250**

CENTRIFUGAL PUMP PERFORMANCE DATA

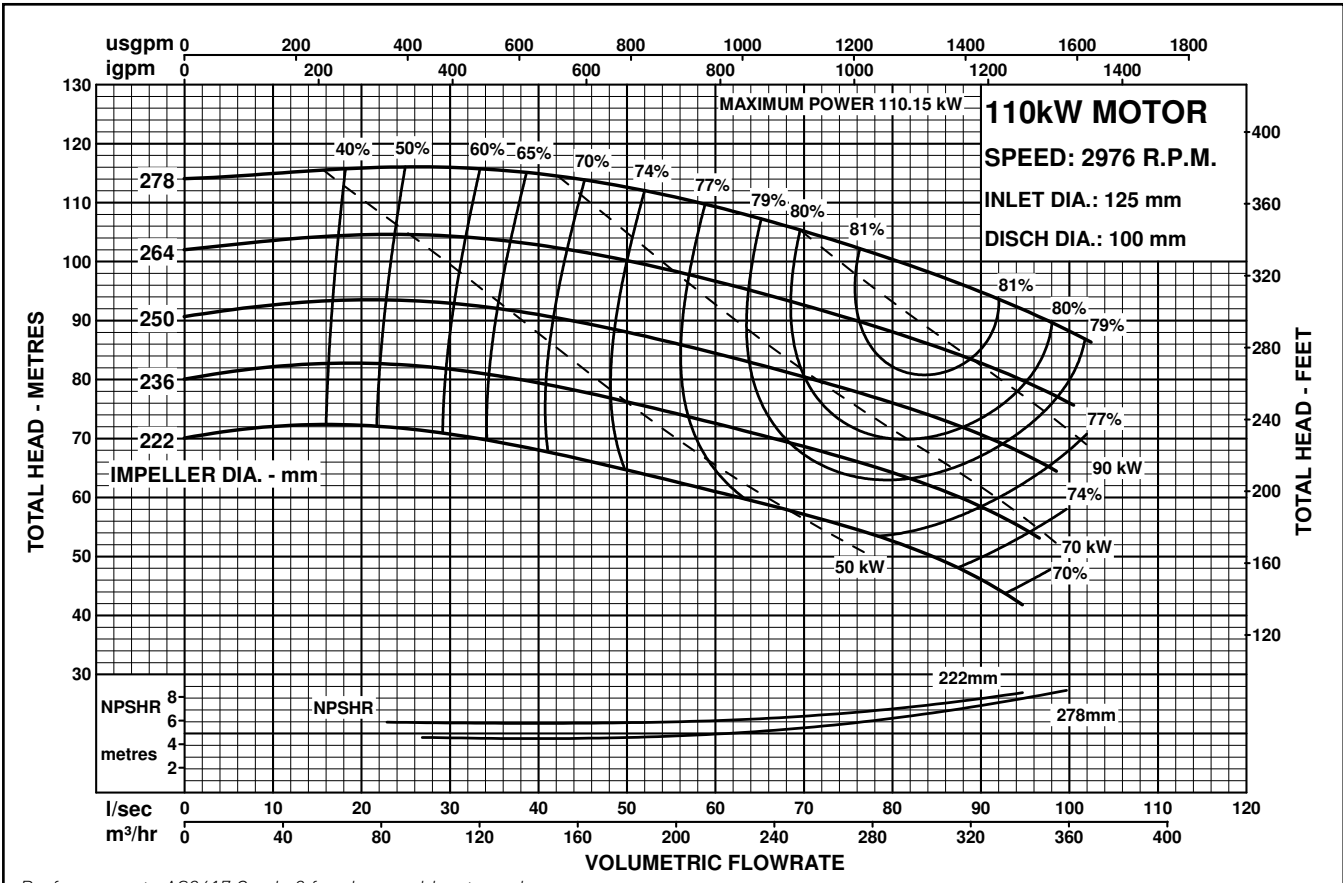

Performance to AS2417 Grade 2 for clean, cold water only.

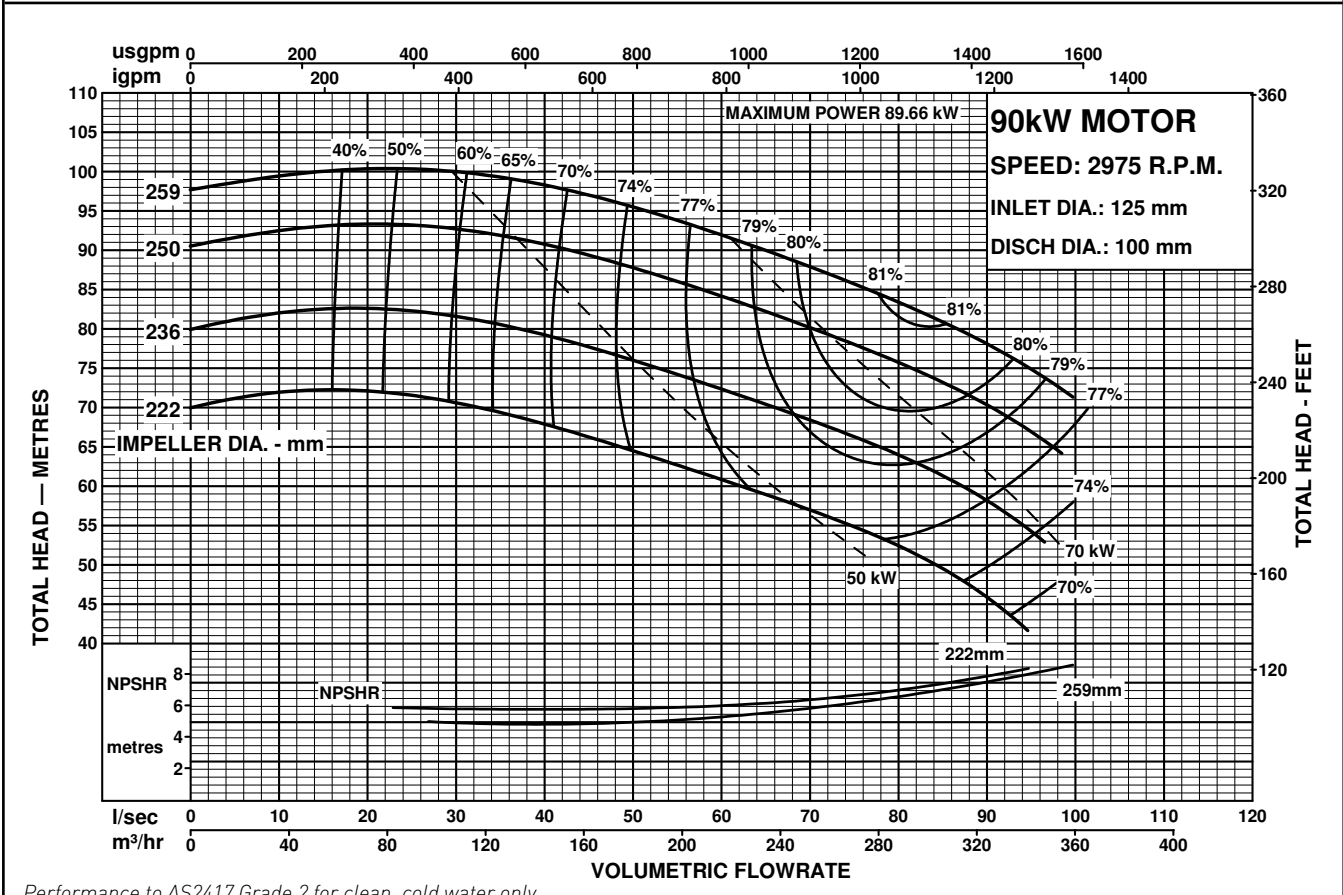

Performance to AS2417 Grade 2 for clean, cold water only.





# PENTAIR STARLINE

MOTORPUMPS

50Hz PERFORMANCE

## MODEL 125x100-250

CENTRIFUGAL PUMP PERFORMANCE DATA

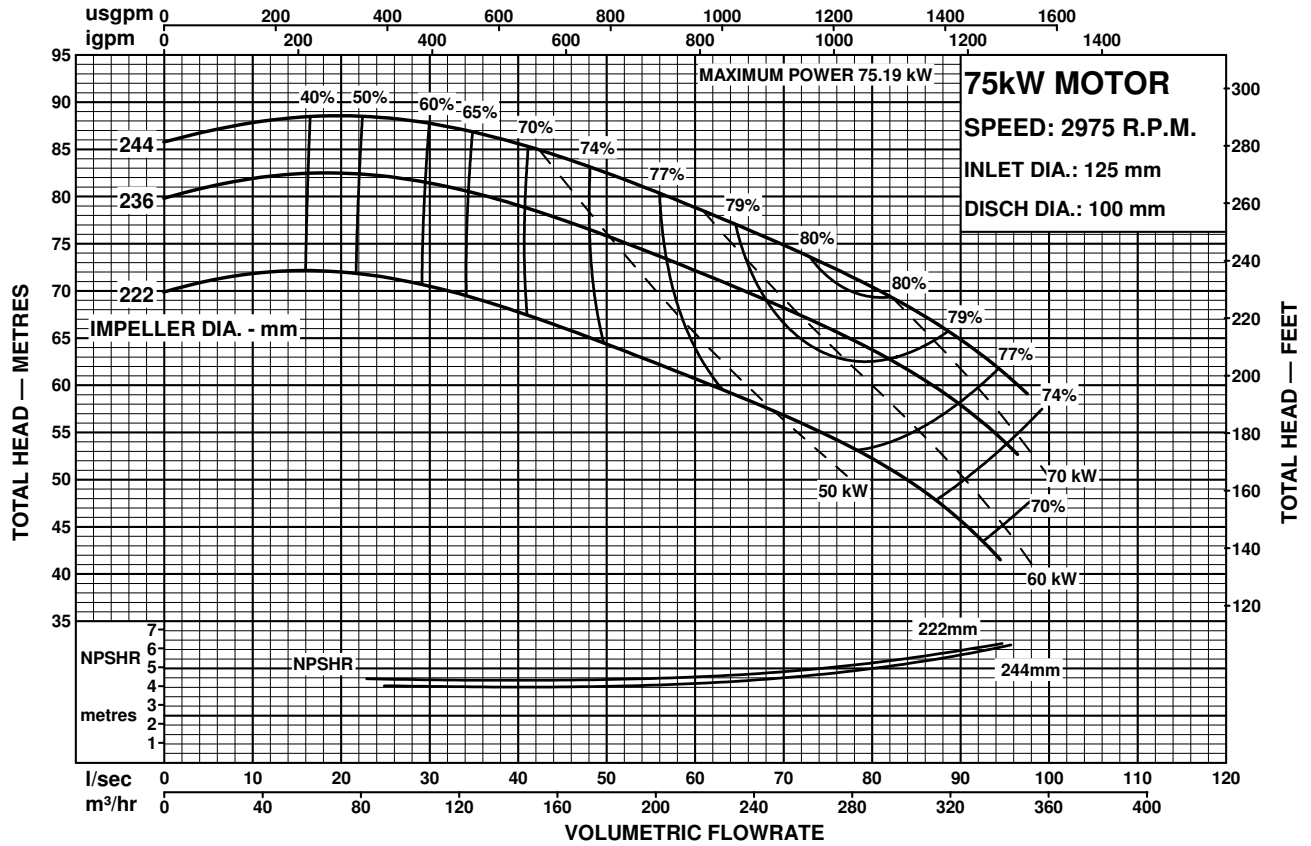

Performance to AS2417 Grade 2 for clean, cold water only.

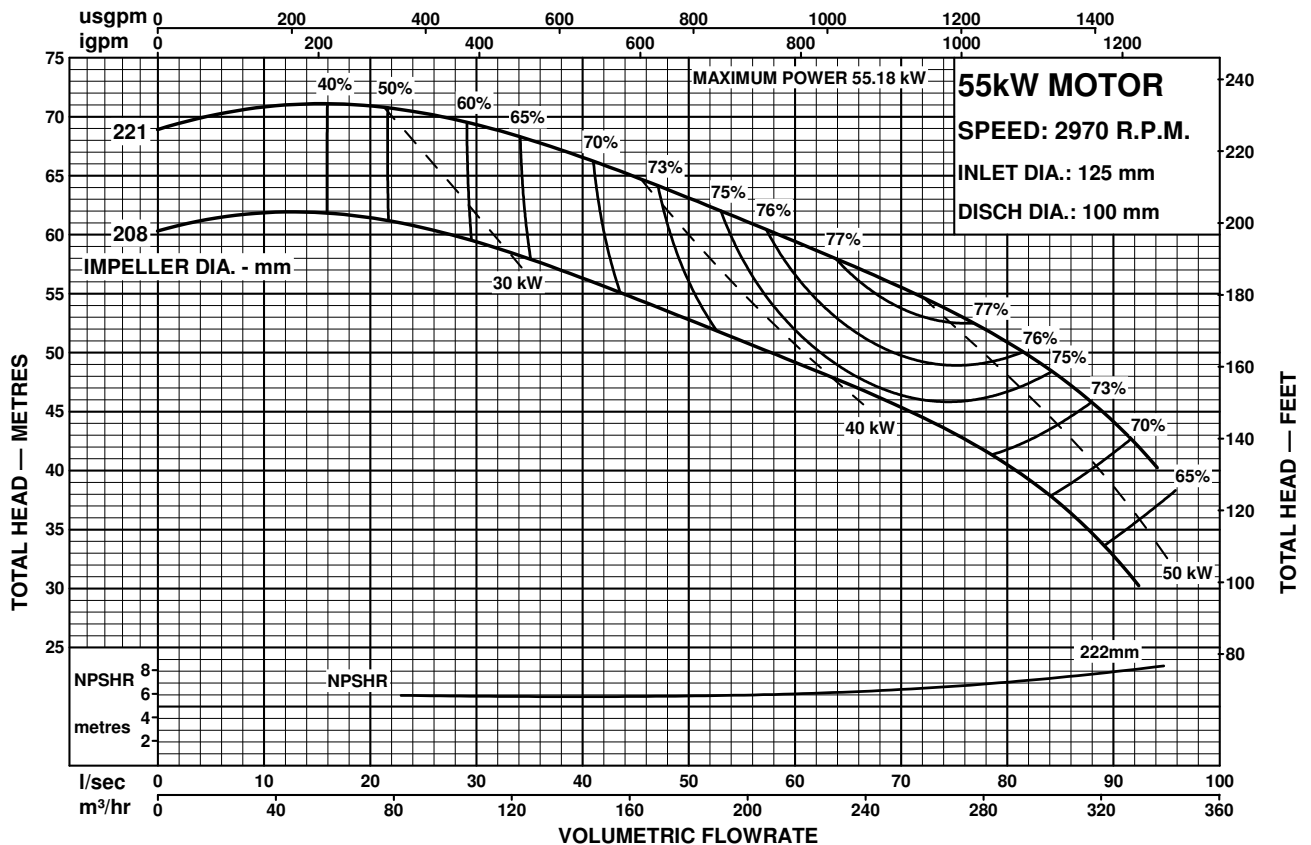

Performance to AS2417 Grade 2 for clean, cold water only.





# PENTAIR STARLINE

MOTORPUMPS  
50Hz PERFORMANCE

MODEL  
**125x100-315**

CENTRIFUGAL PUMP PERFORMANCE DATA

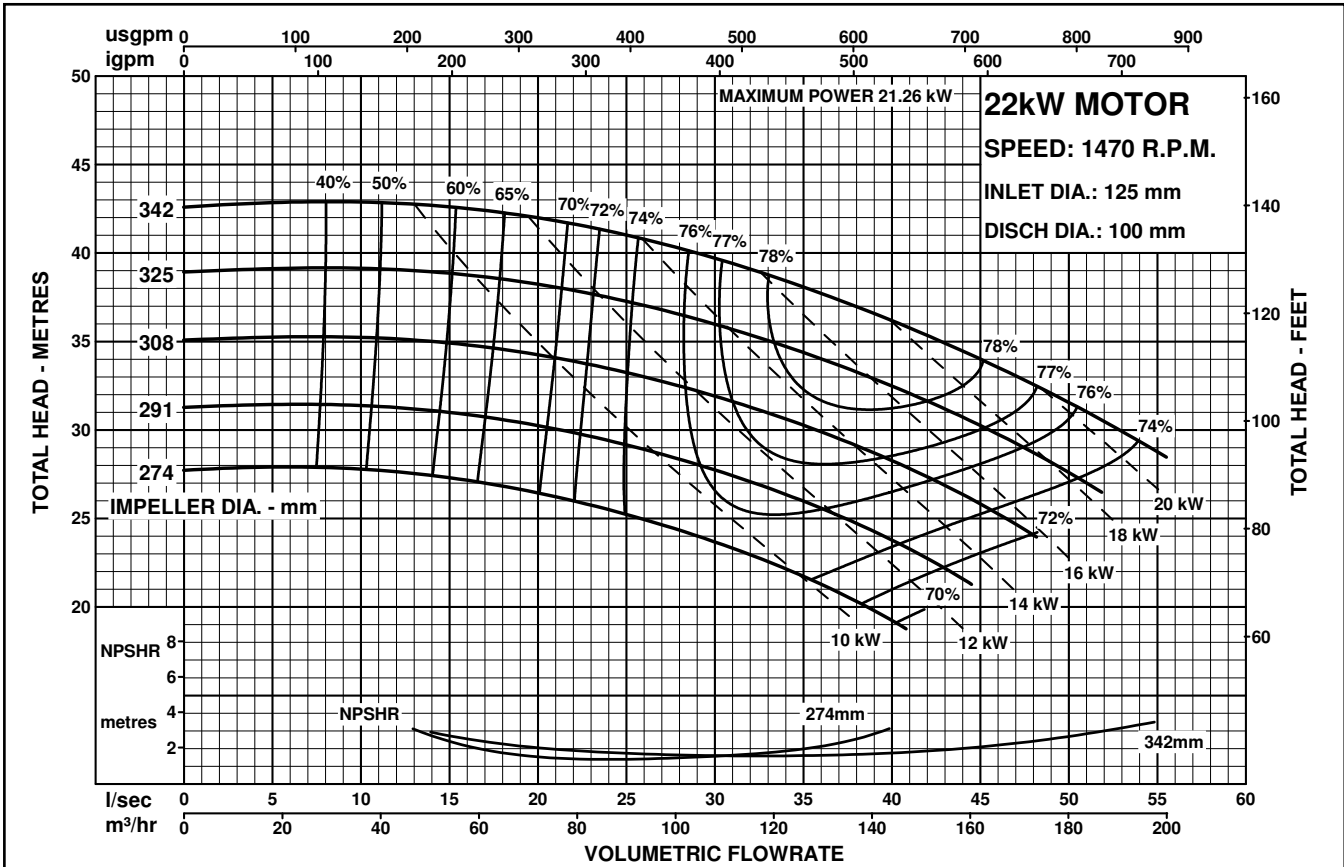

Performance to AS2417 Grade 2 for clean, cold water only.

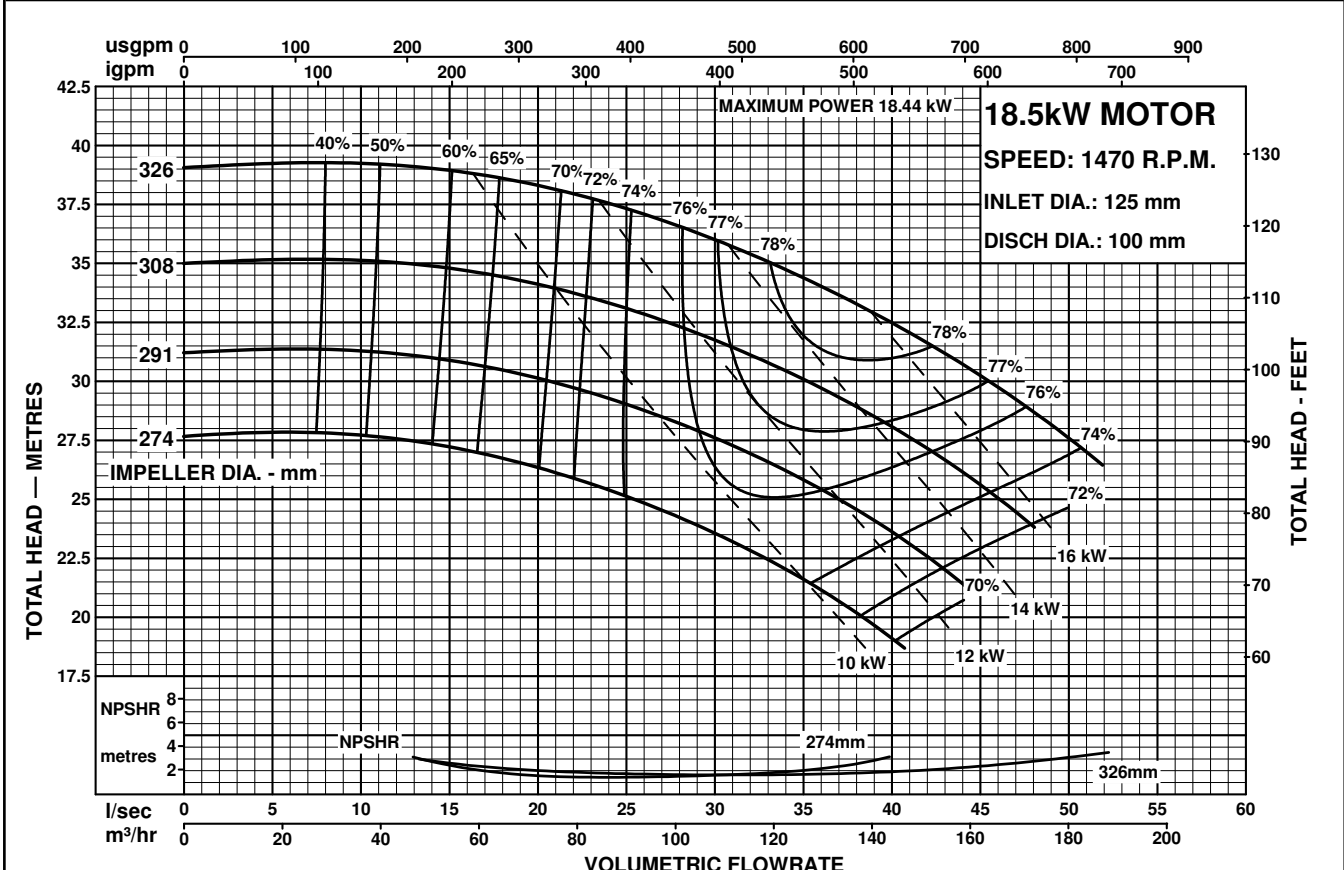

Performance to AS2417 Grade 2 for clean, cold water only.





# PENTAIR STARLINE

MOTORPUMPS

50Hz PERFORMANCE

## MODEL 125x100-315

CENTRIFUGAL PUMP PERFORMANCE DATA

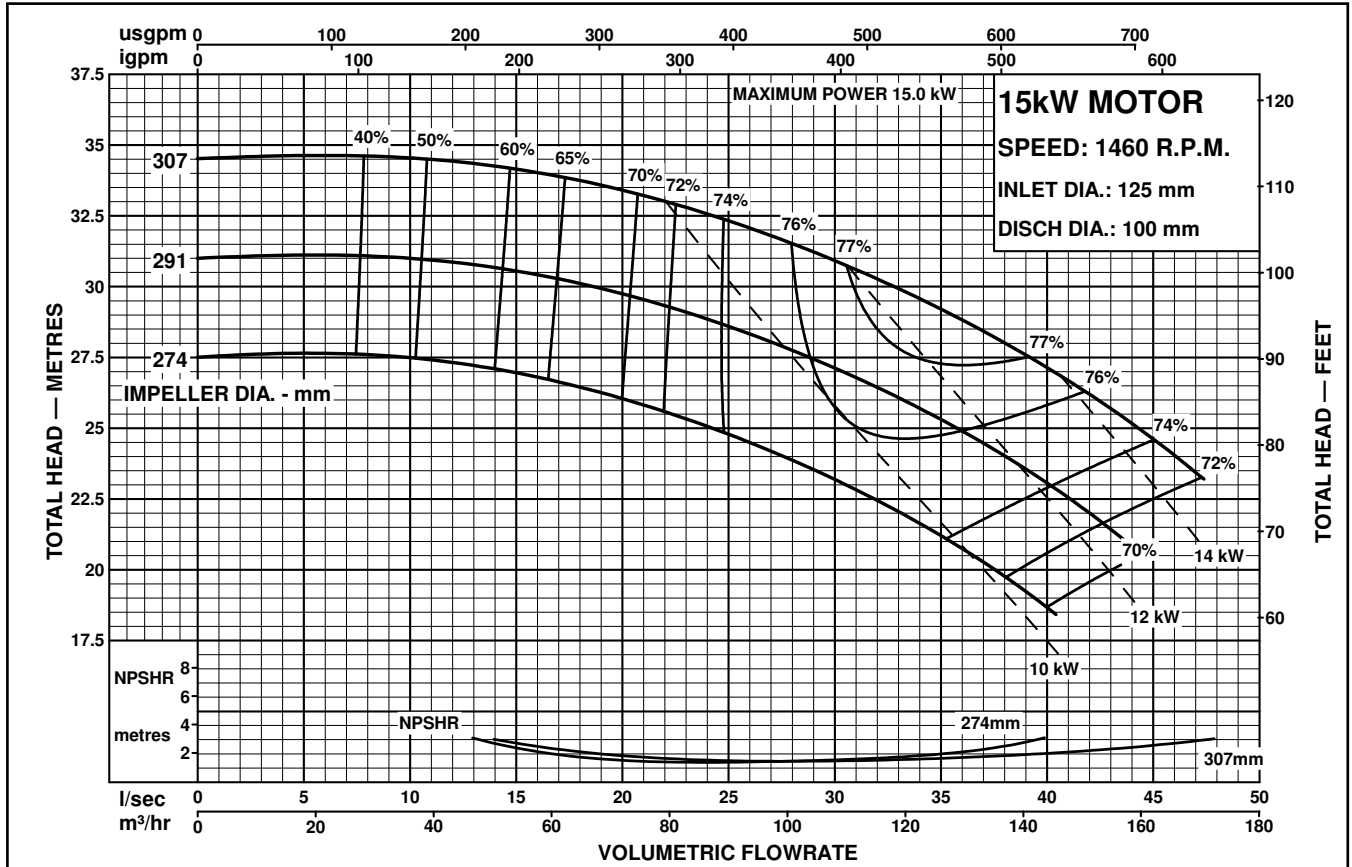

Performance to AS2417 Grade 2 for clean, cold water only.

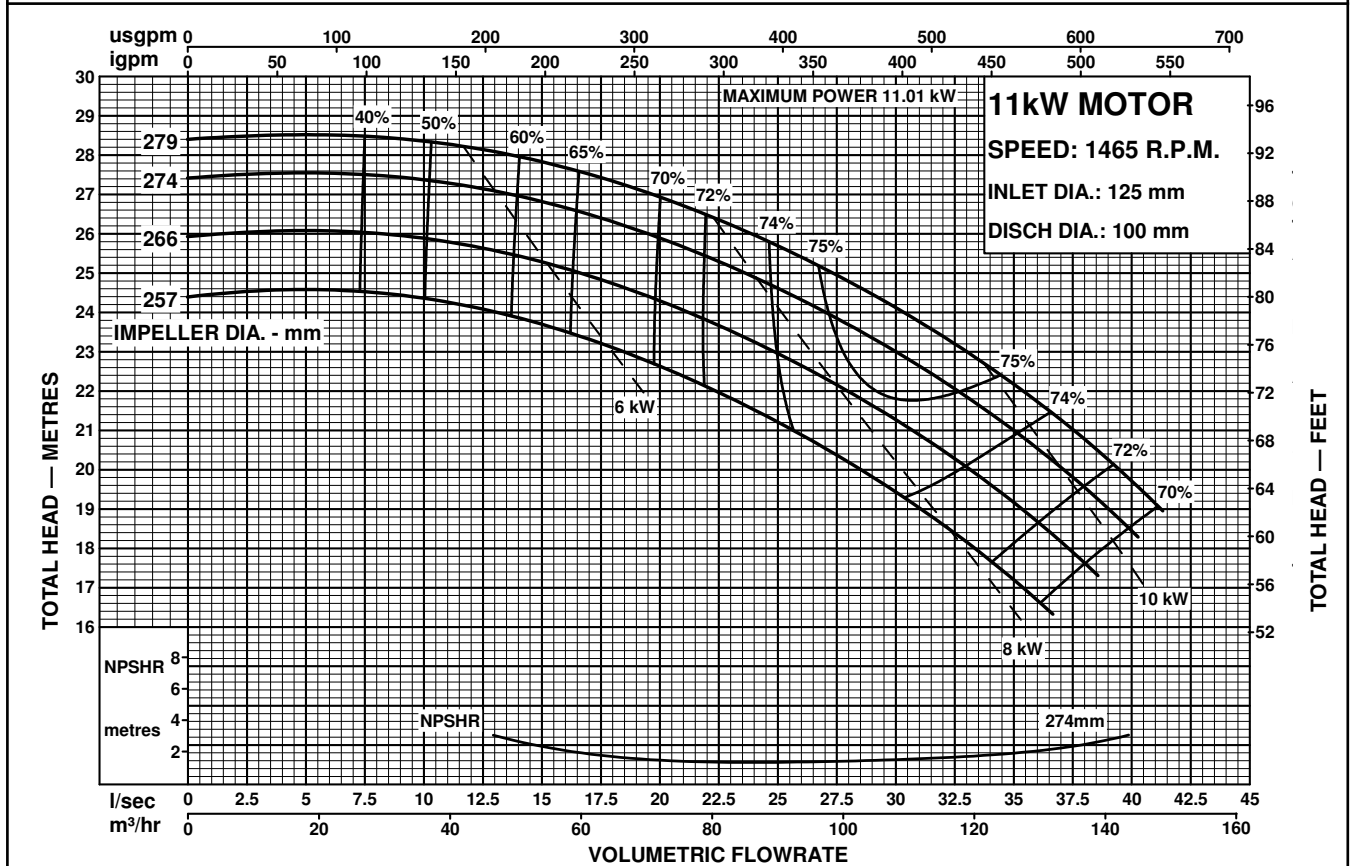

Performance to AS2417 Grade 2 for clean, cold water only.





# PENTAIR STARLINE

MOTORPUMPS  
50Hz PERFORMANCE

MODEL  
**125x100-315**

CENTRIFUGAL PUMP PERFORMANCE DATA

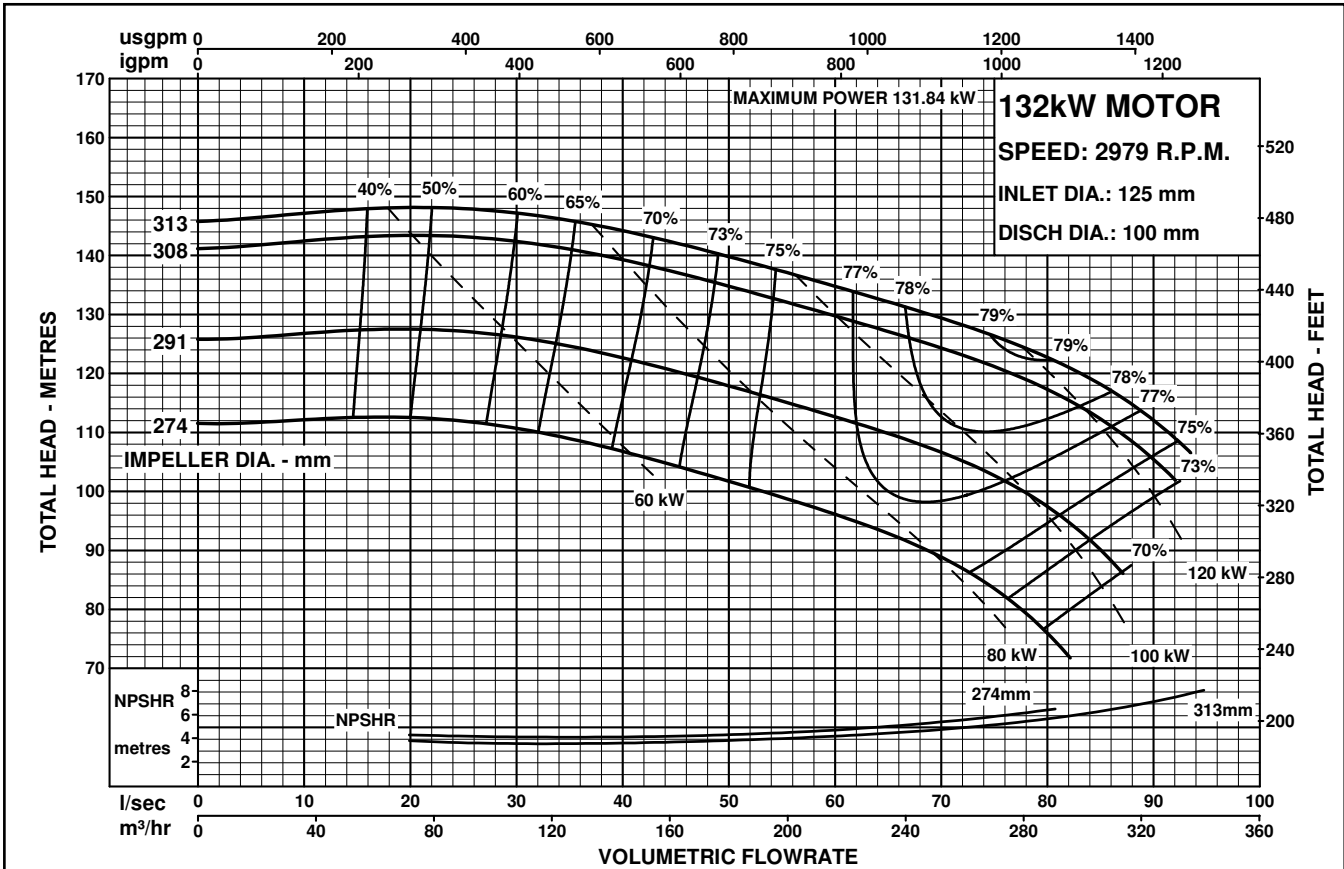

Performance to AS2417 Grade 2 for clean, cold water only.

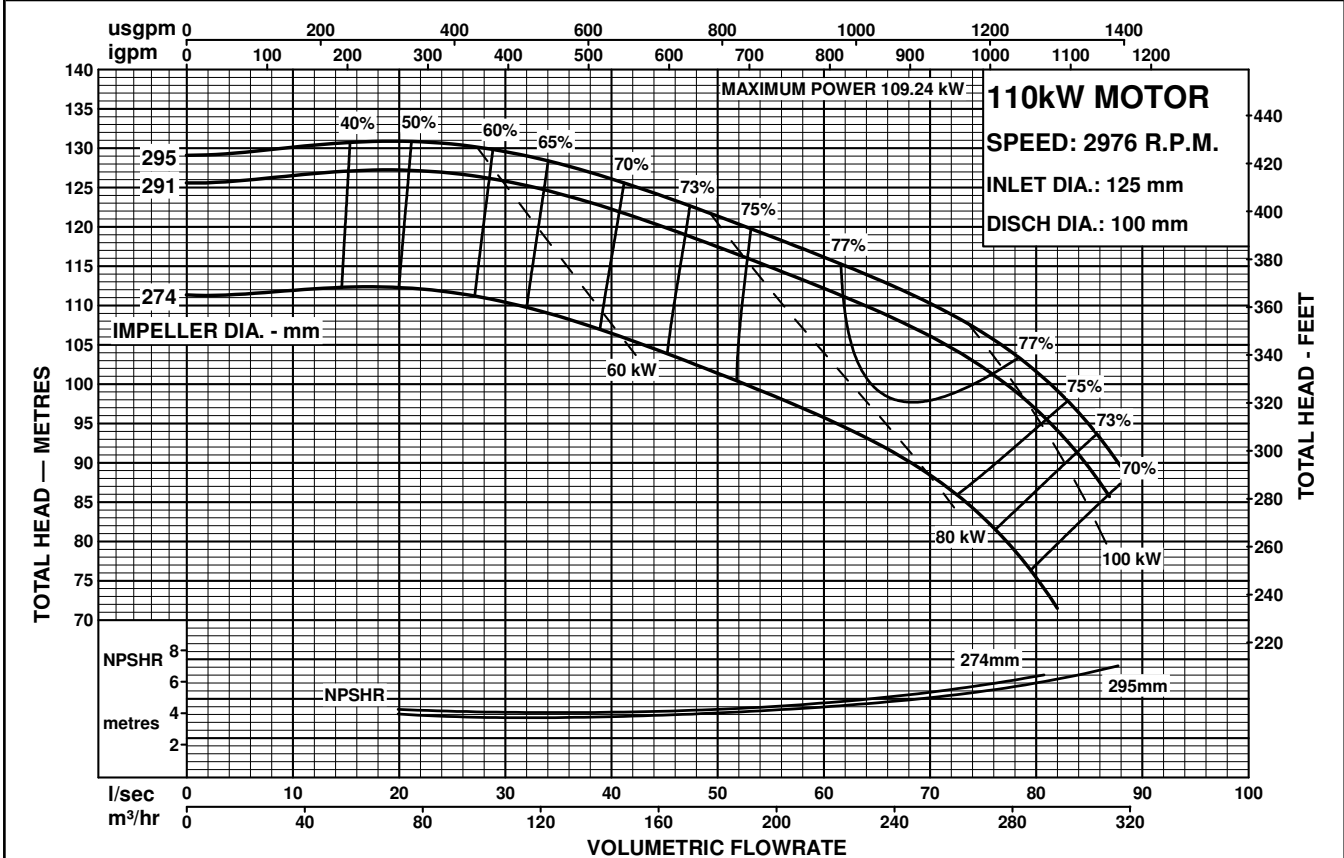

Performance to AS2417 Grade 2 for clean, cold water only.





# PENTAIR STARLINE

MOTORPUMPS  
50Hz PERFORMANCE

MODEL  
**125x100-315**

CENTRIFUGAL PUMP PERFORMANCE DATA

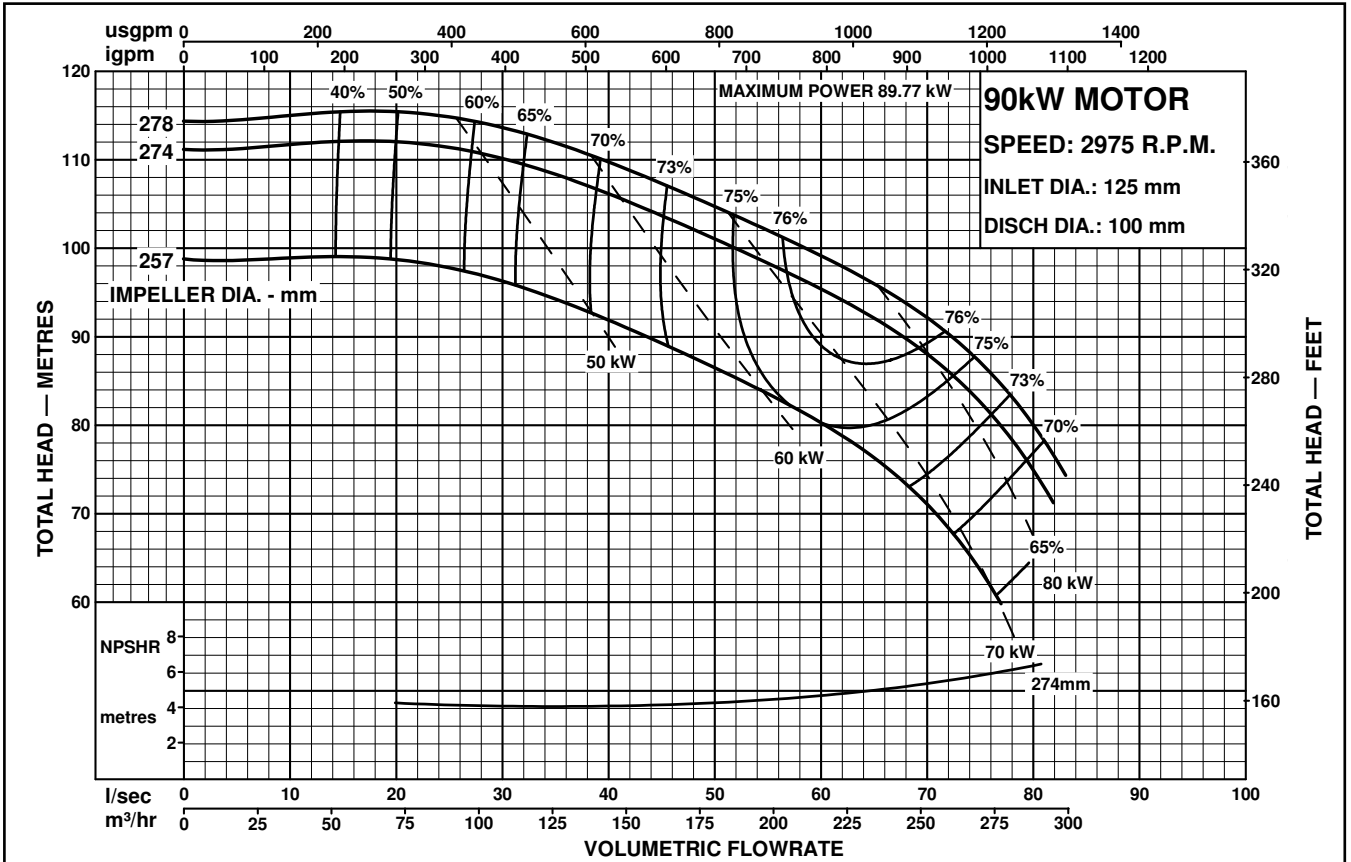

Performance to AS2417 Grade 2 for clean, cold water only.





# PENTAIR STARLINE

MOTORPUMPS  
50Hz PERFORMANCE

MODEL  
**125x100-400**

CENTRIFUGAL PUMP PERFORMANCE DATA

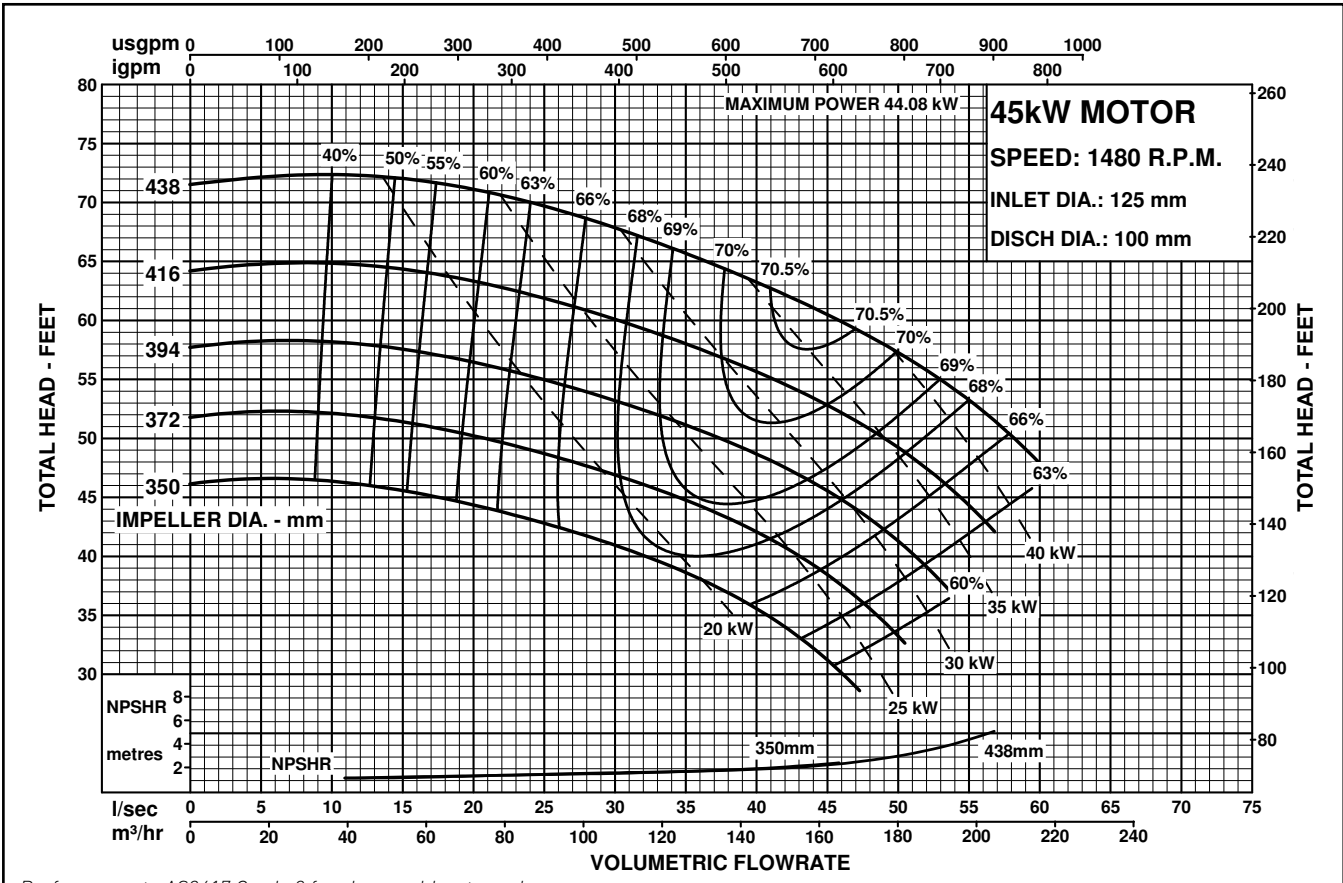

Performance to AS2417 Grade 2 for clean, cold water only.

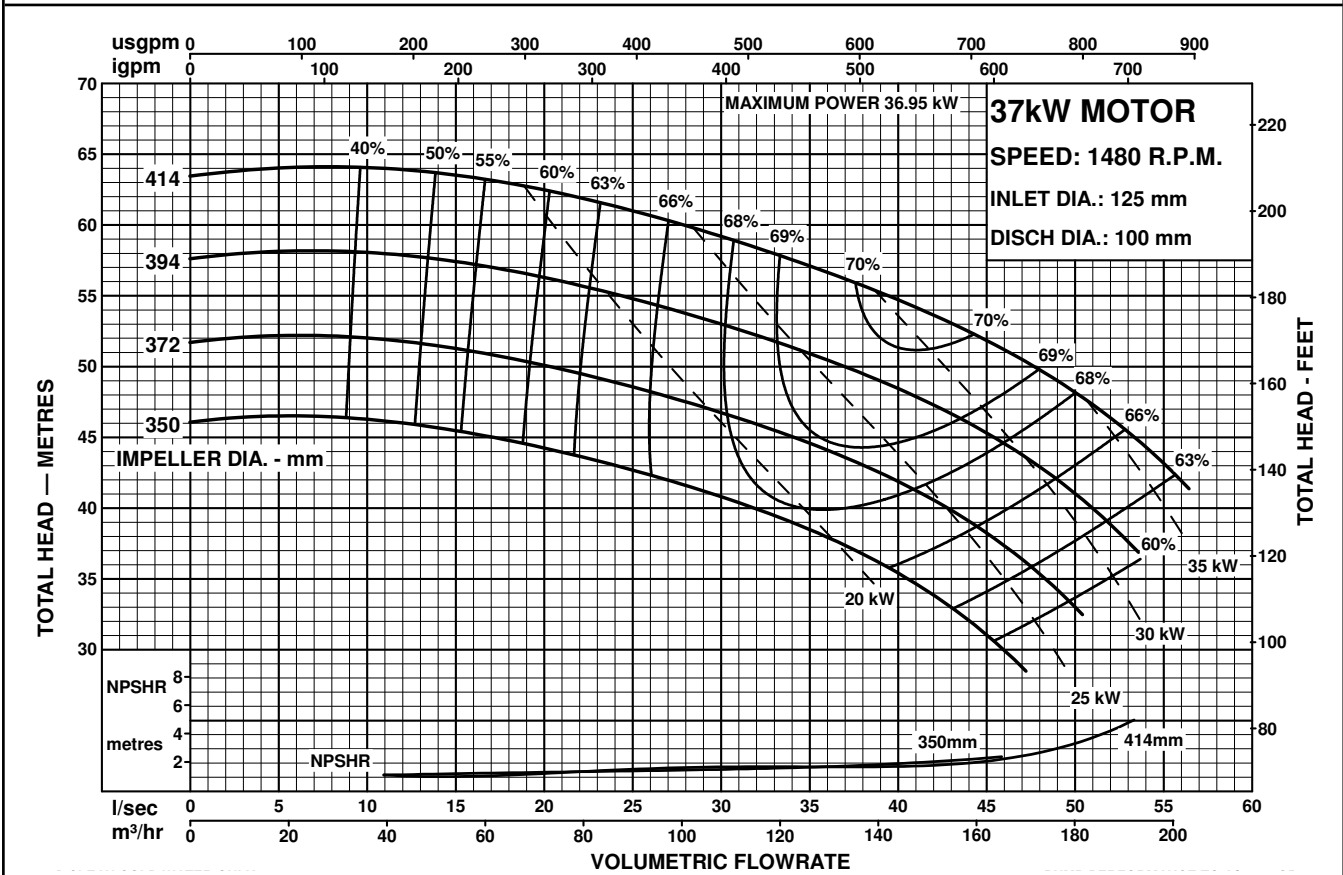

Performance to AS2417 Grade 2 for clean, cold water only.







# PENTAIR STARLINE

MOTORPUMPS

50Hz PERFORMANCE

## MODEL 125x100-400

CENTRIFUGAL PUMP PERFORMANCE DATA

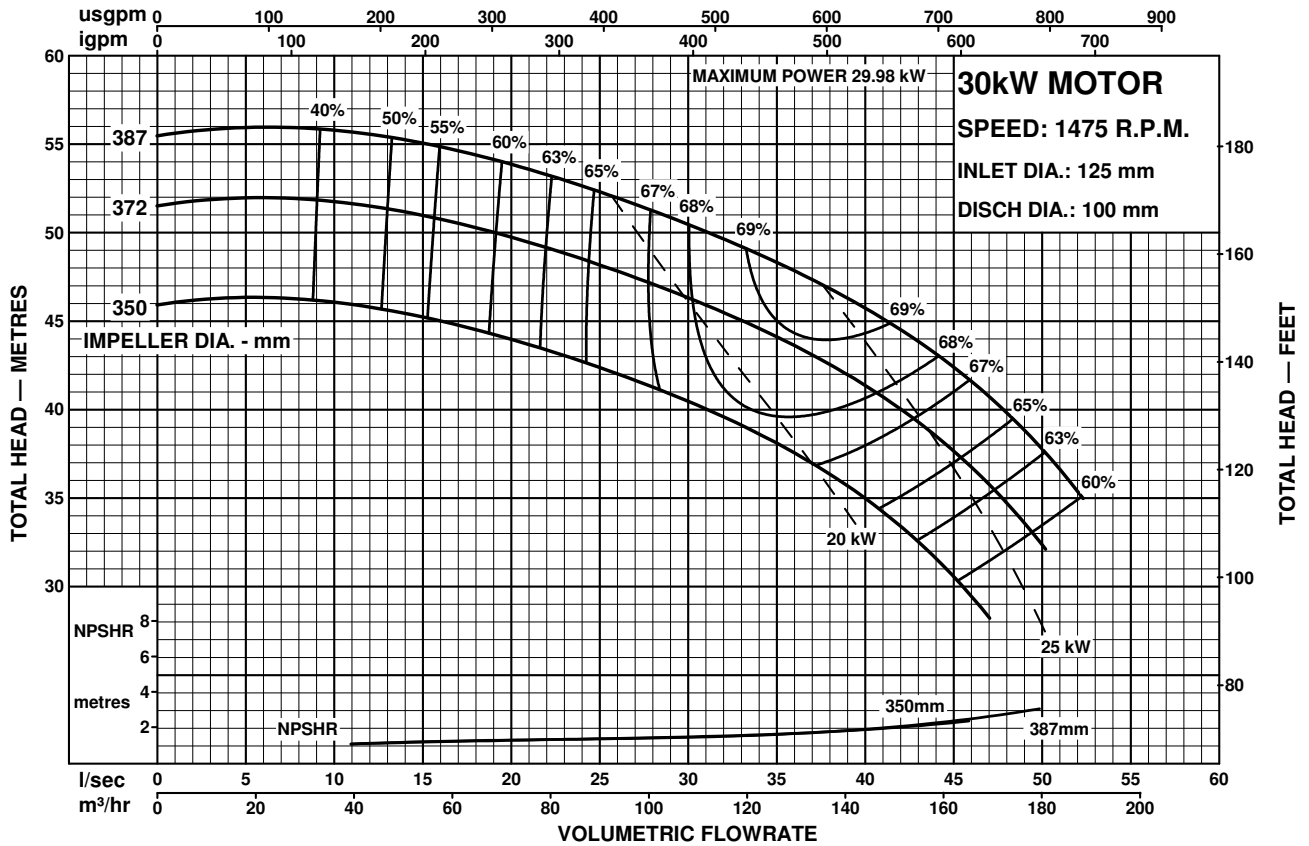

Performance to AS2417 Grade 2 for clean, cold water only.

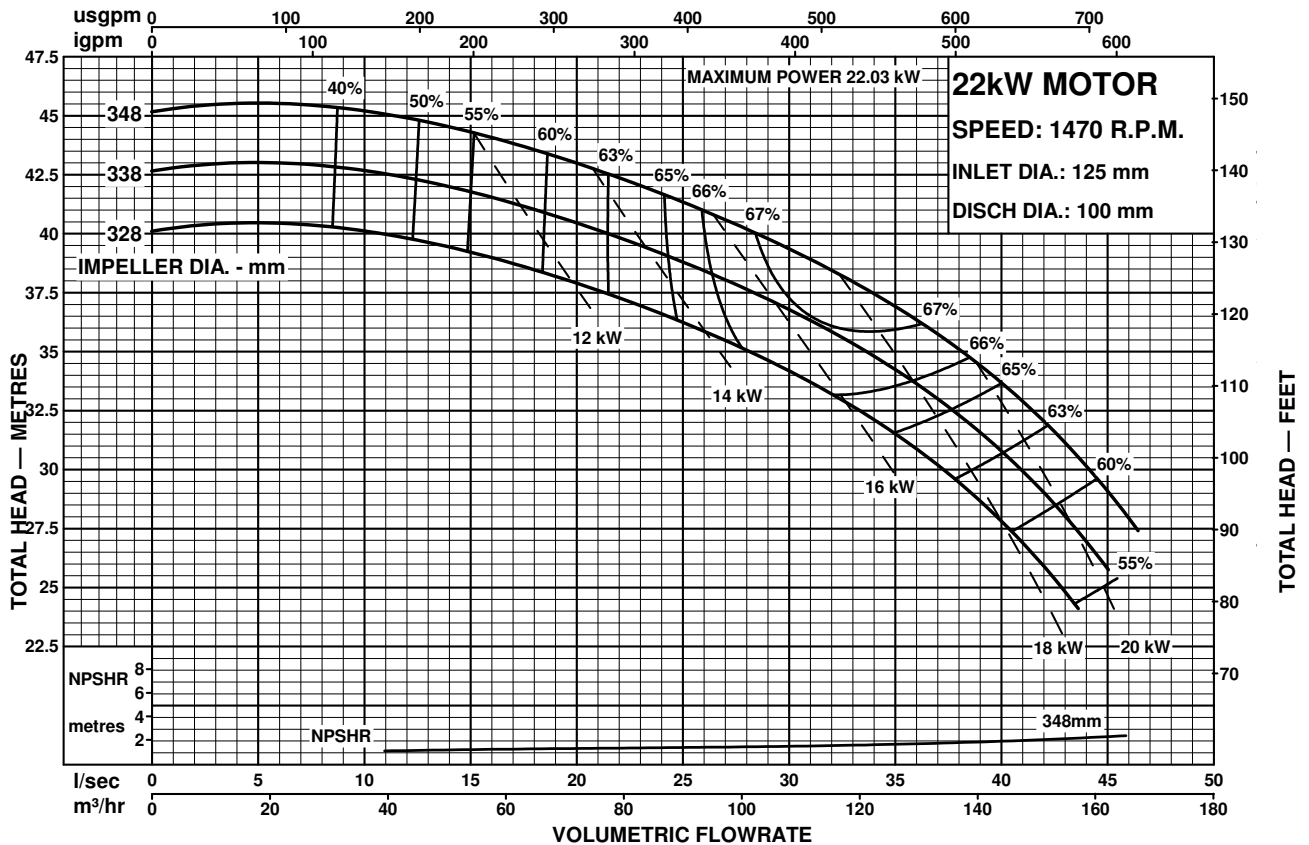

Performance to AS2417 Grade 2 for clean, cold water only.





# PENTAIR STARLINE

MOTORPUMPS  
50Hz PERFORMANCE

MODEL  
**125x100-500**

CENTRIFUGAL PUMP PERFORMANCE DATA

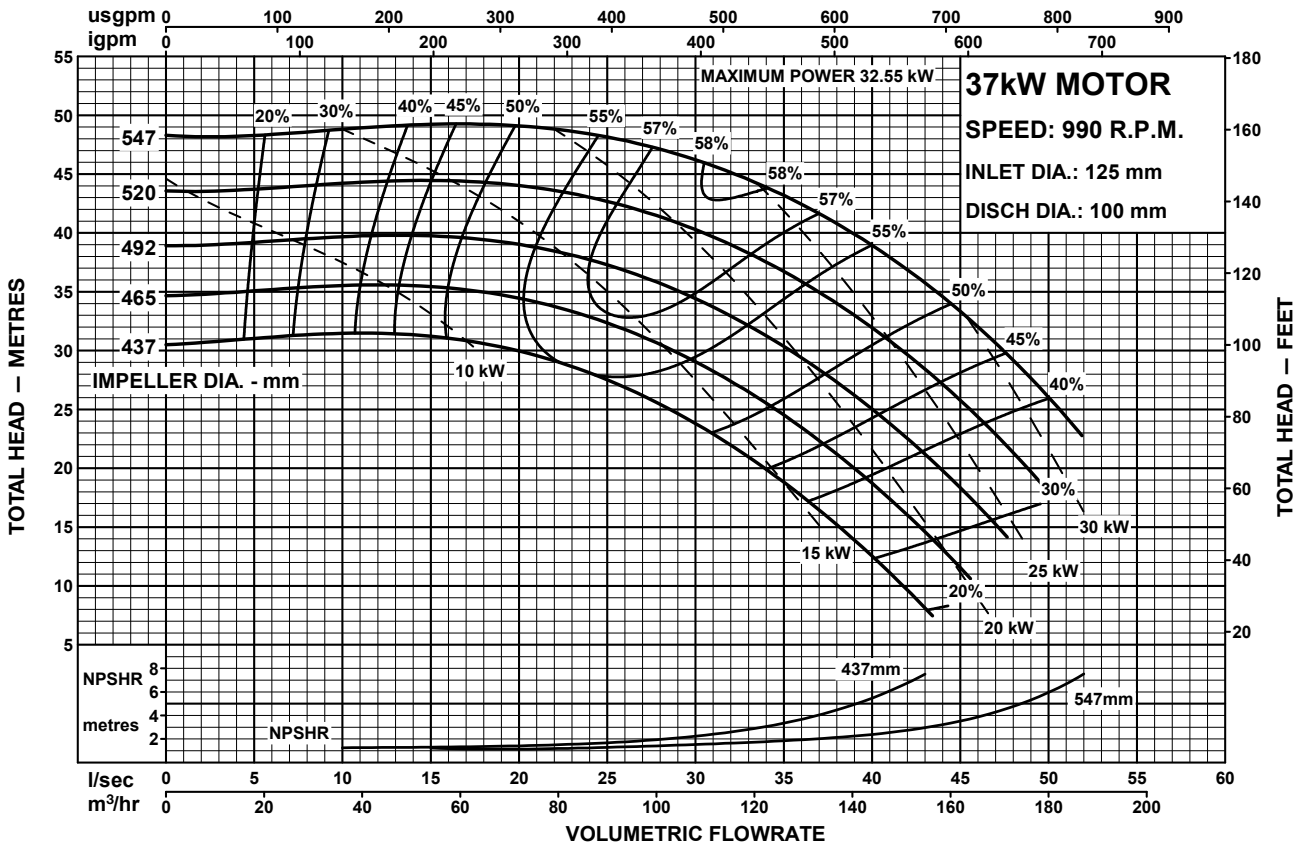

Performance to AS2417 Grade 2 for clean, cold water only.

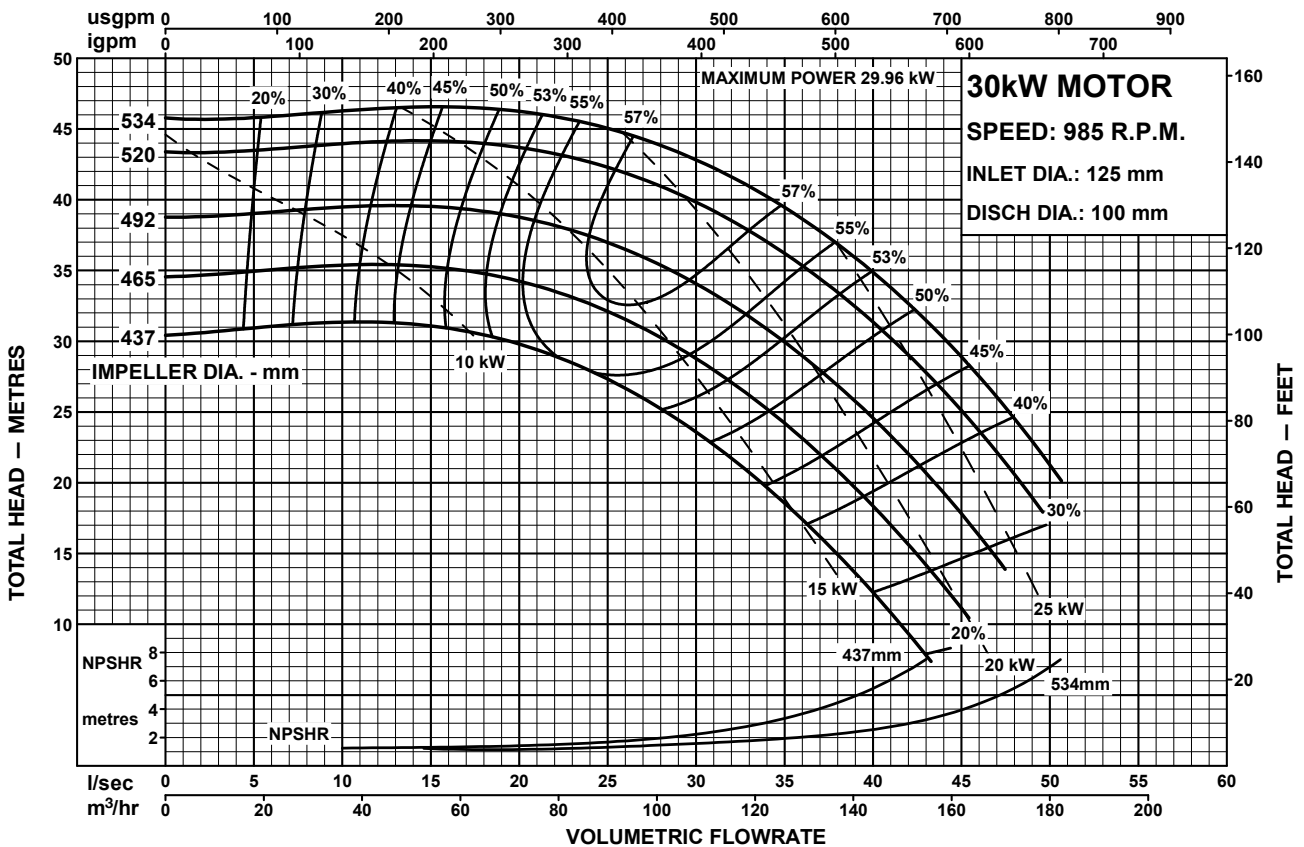

Performance to AS2417 Grade 2 for clean, cold water only.





# PENTAIR STARLINE

MOTORPUMPS

50Hz PERFORMANCE

## MODEL 125x100-500

CENTRIFUGAL PUMP PERFORMANCE DATA

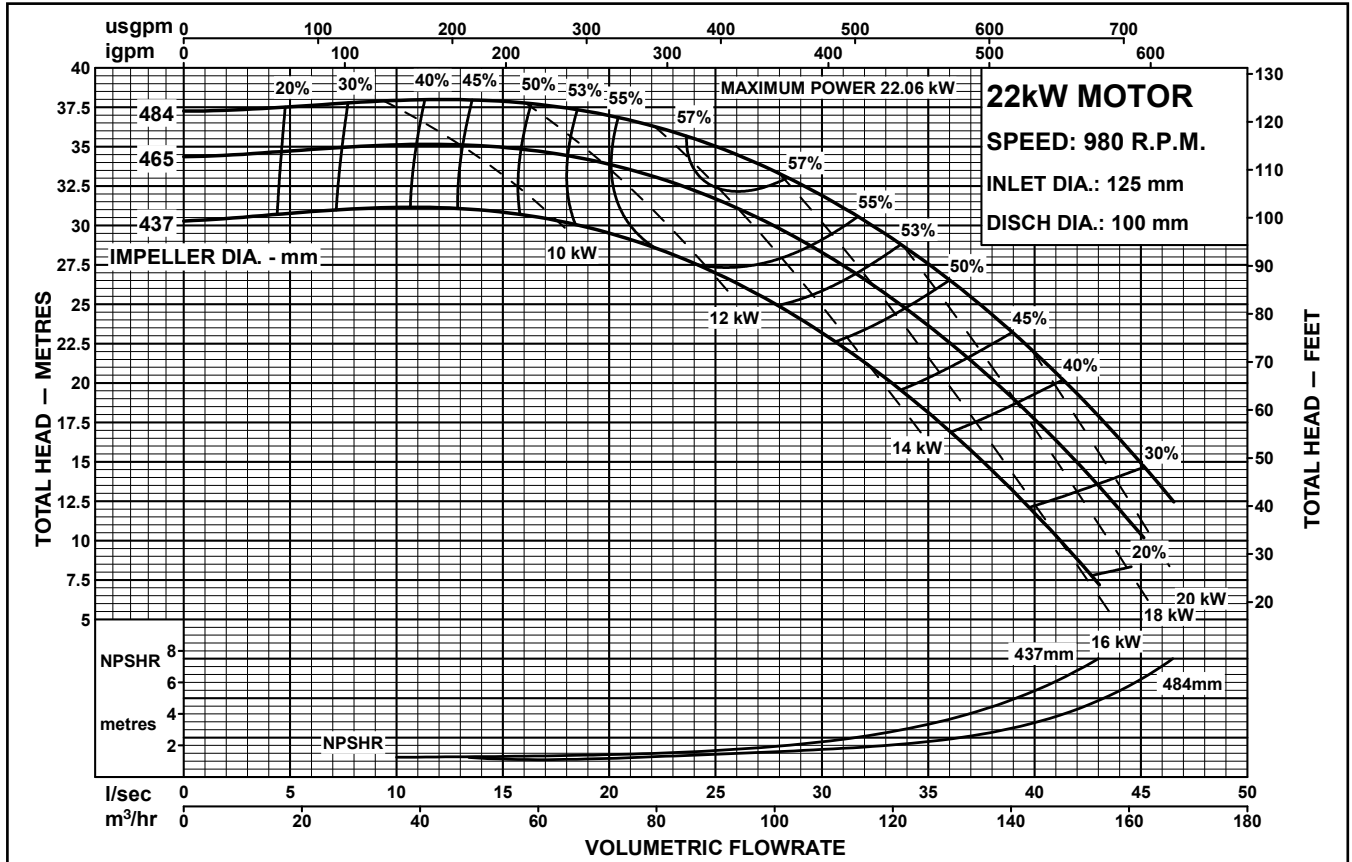

Performance to AS2417 Grade 2 for clean, cold water only.

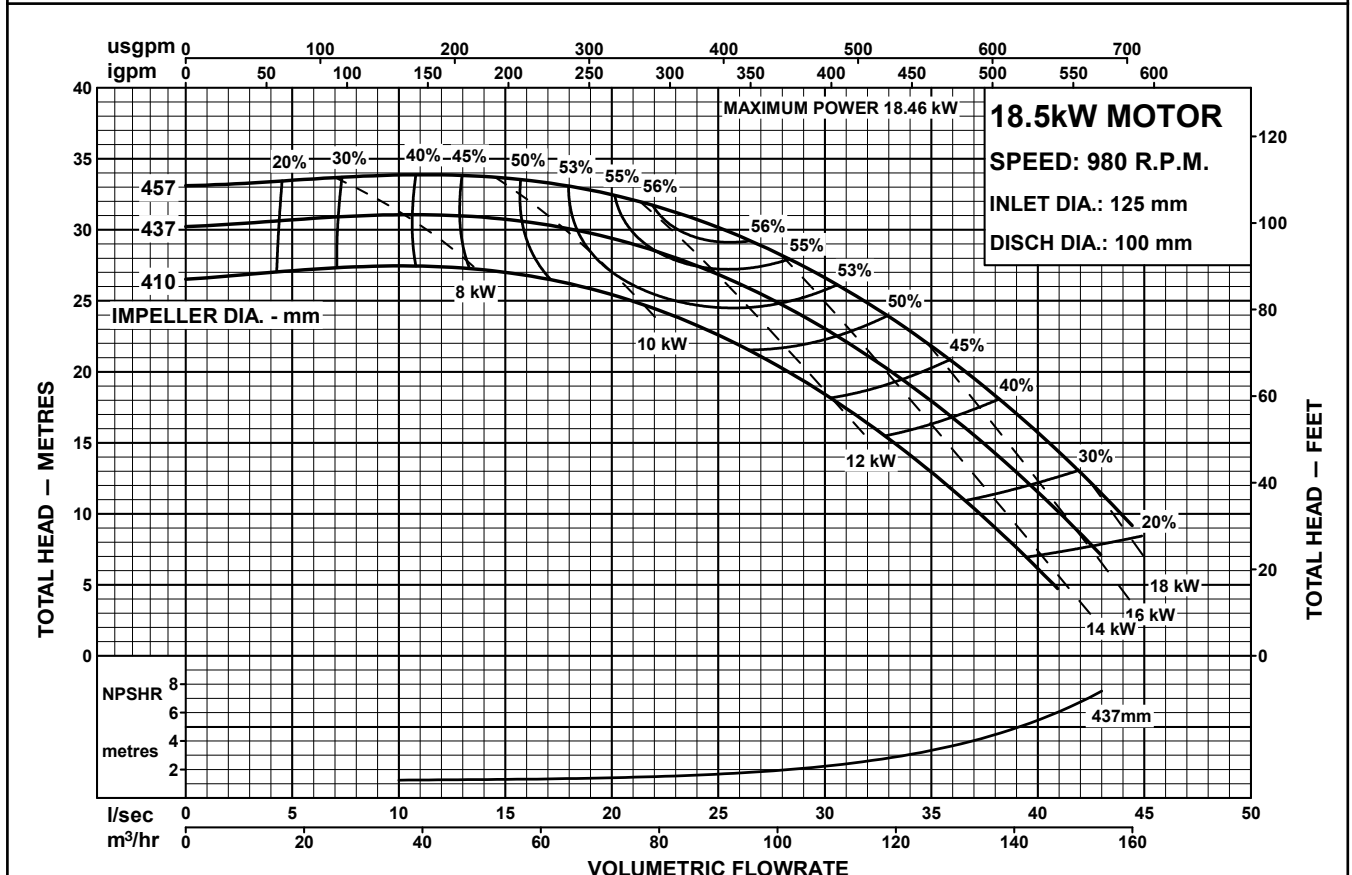

Performance to AS2417 Grade 2 for clean, cold water only.





# PENTAIR STARLINE

MOTORPUMPS  
50Hz PERFORMANCE

MODEL  
**125x100-500**

CENTRIFUGAL PUMP PERFORMANCE DATA

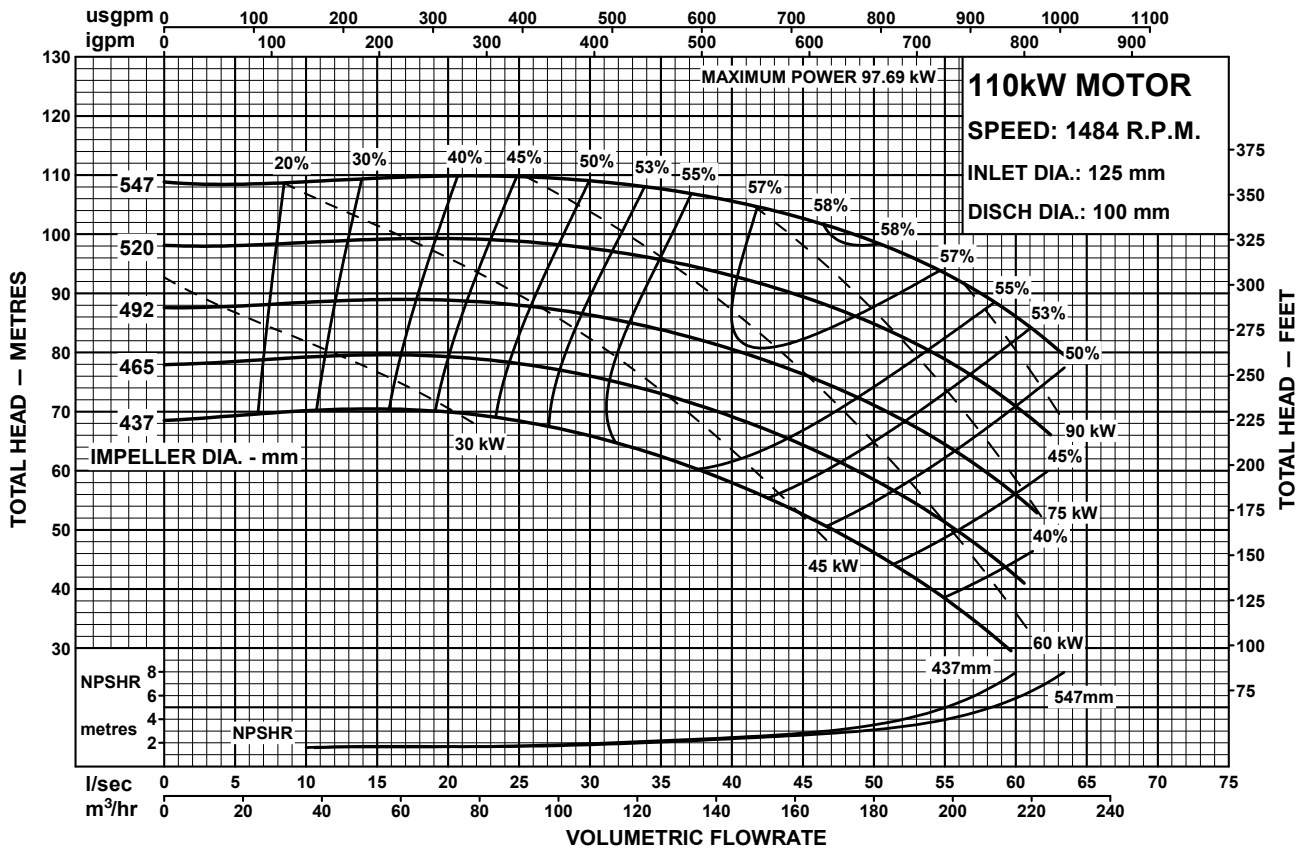

Performance to AS2417 Grade 2 for clean, cold water only.

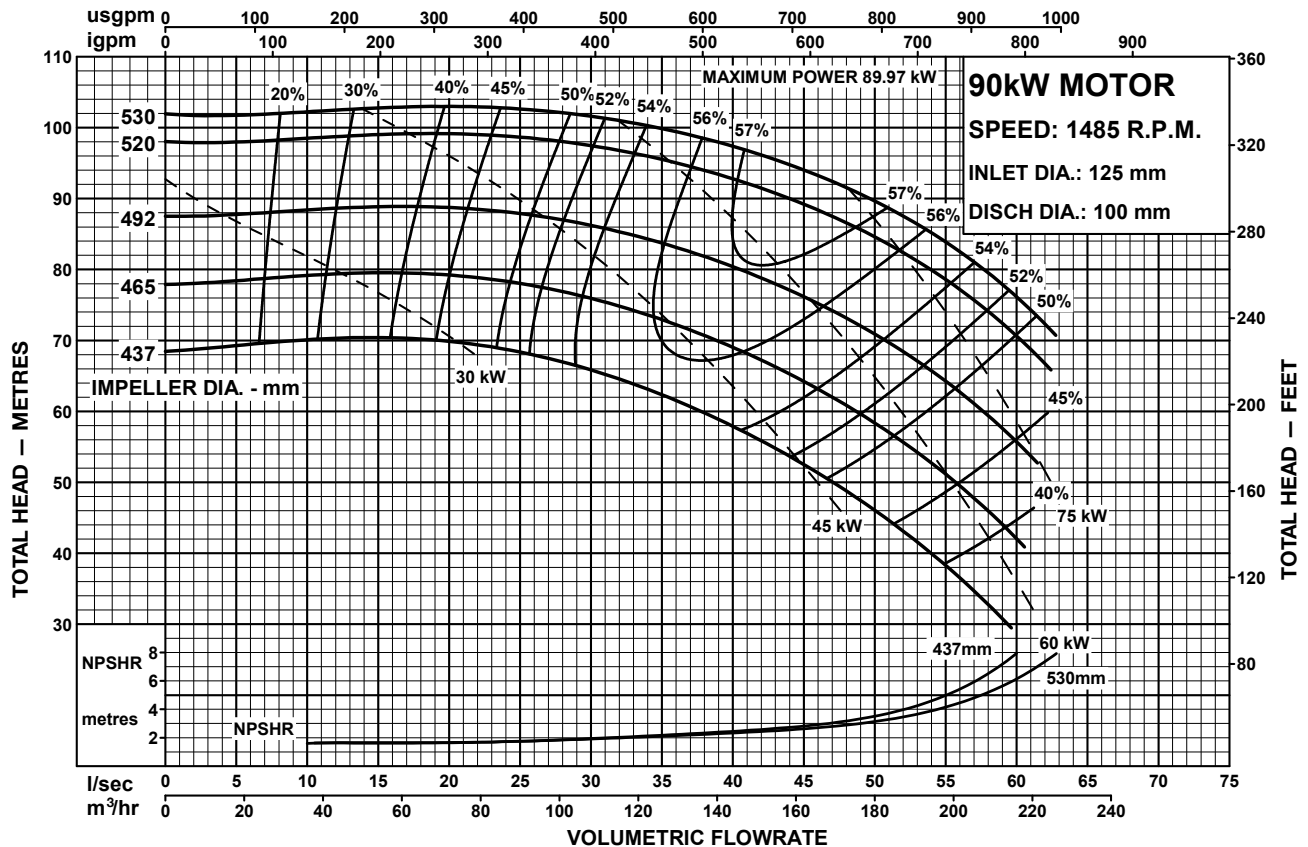

Performance to AS2417 Grade 2 for clean, cold water only.





# PENTAIR STARLINE

MOTORPUMPS

50Hz PERFORMANCE

## MODEL 125x100-500

CENTRIFUGAL PUMP PERFORMANCE DATA

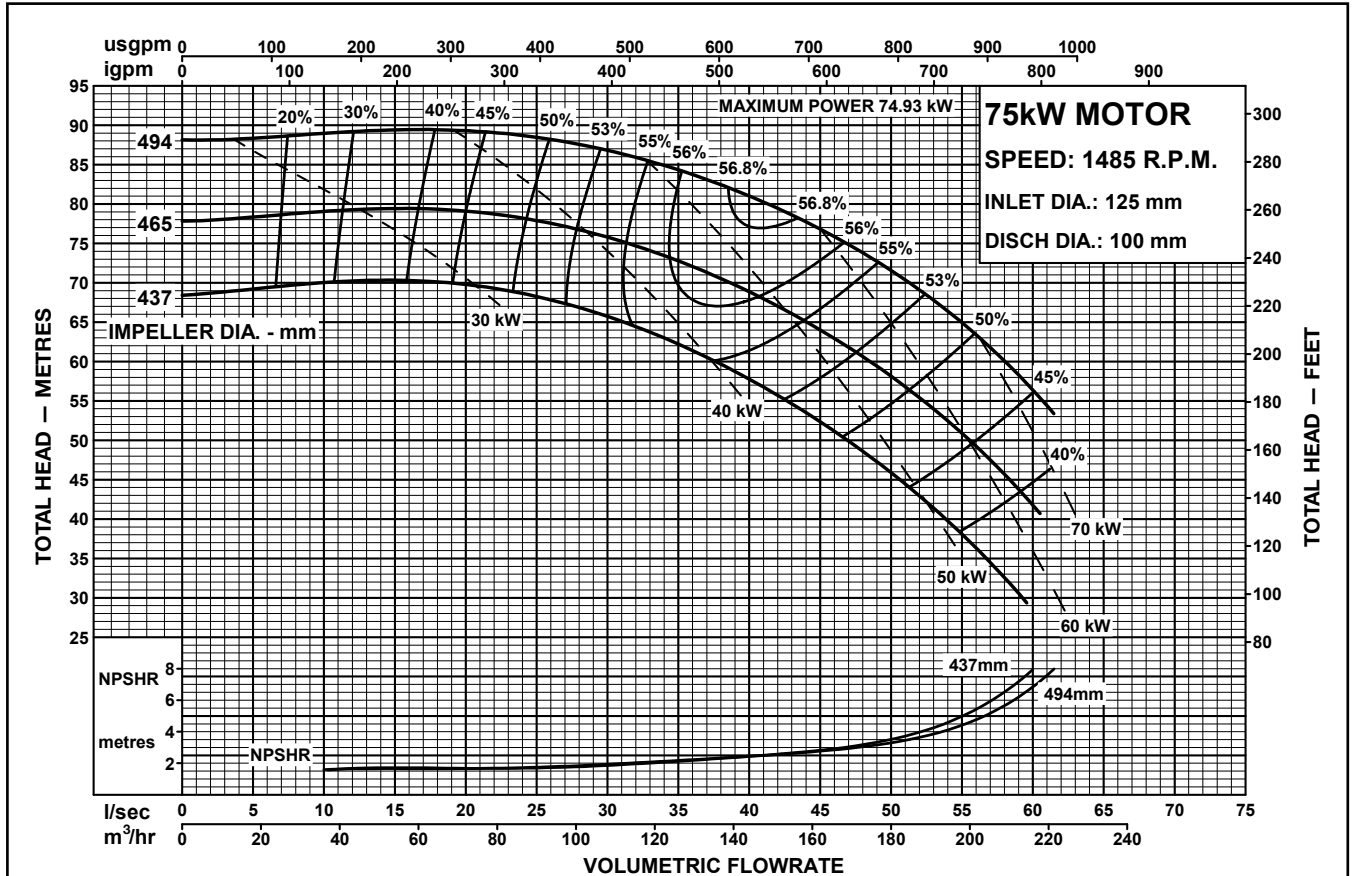

Performance to AS2417 Grade 2 for clean, cold water only.

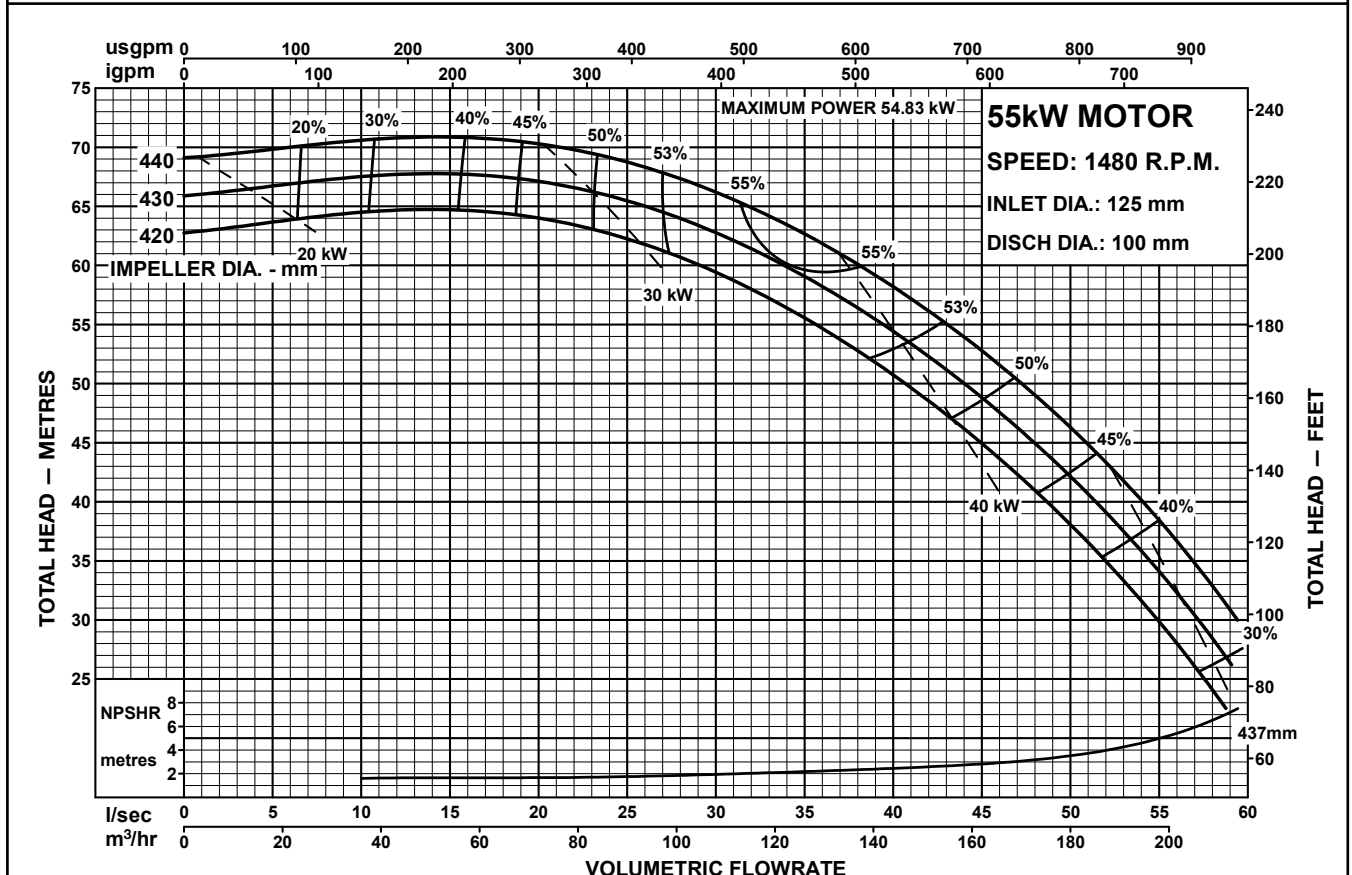

Performance to AS2417 Grade 2 for clean, cold water only.





# PENTAIR STARLINE

MOTORPUMPS  
50Hz PERFORMANCE

MODEL  
**150x125-250**

CENTRIFUGAL PUMP PERFORMANCE DATA

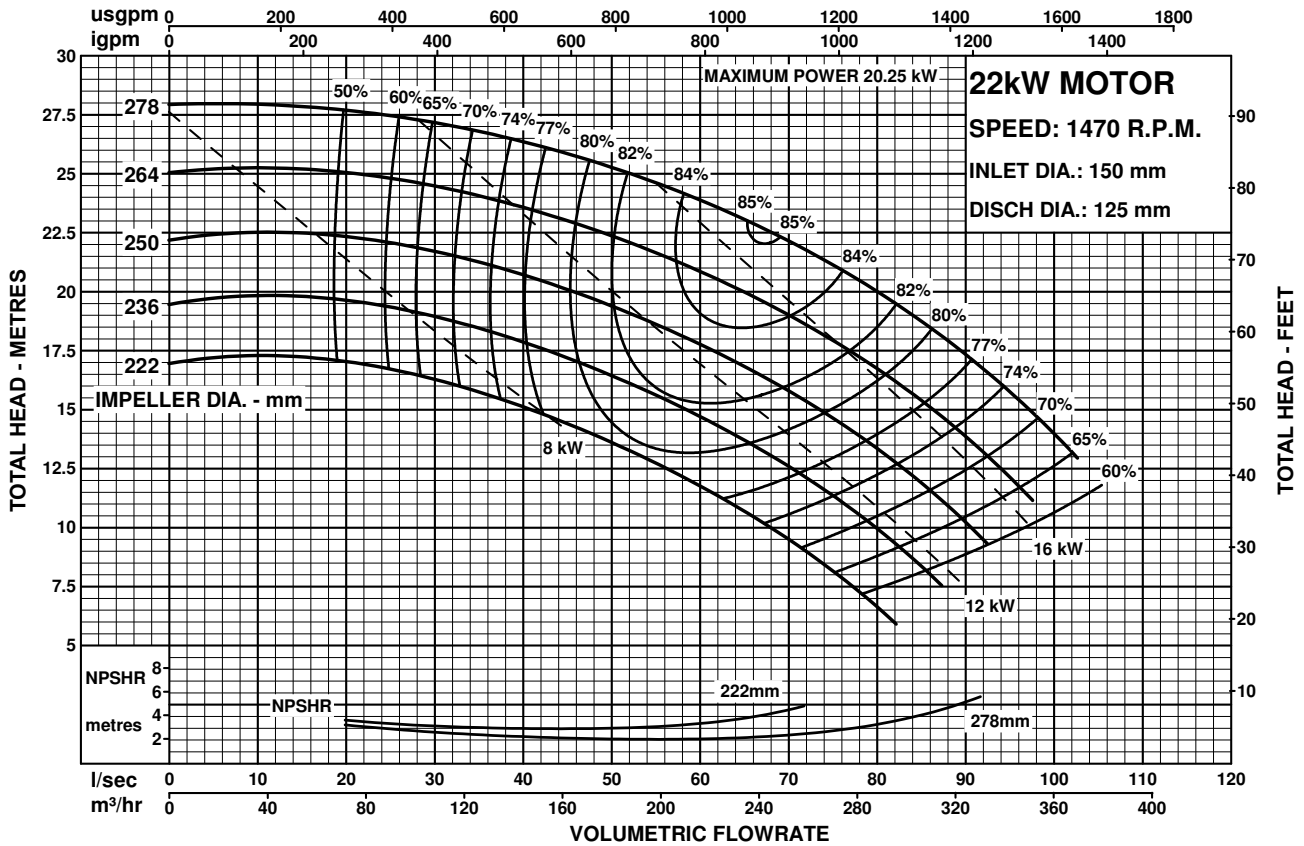

Performance to AS2417 Grade 2 for clean, cold water only.

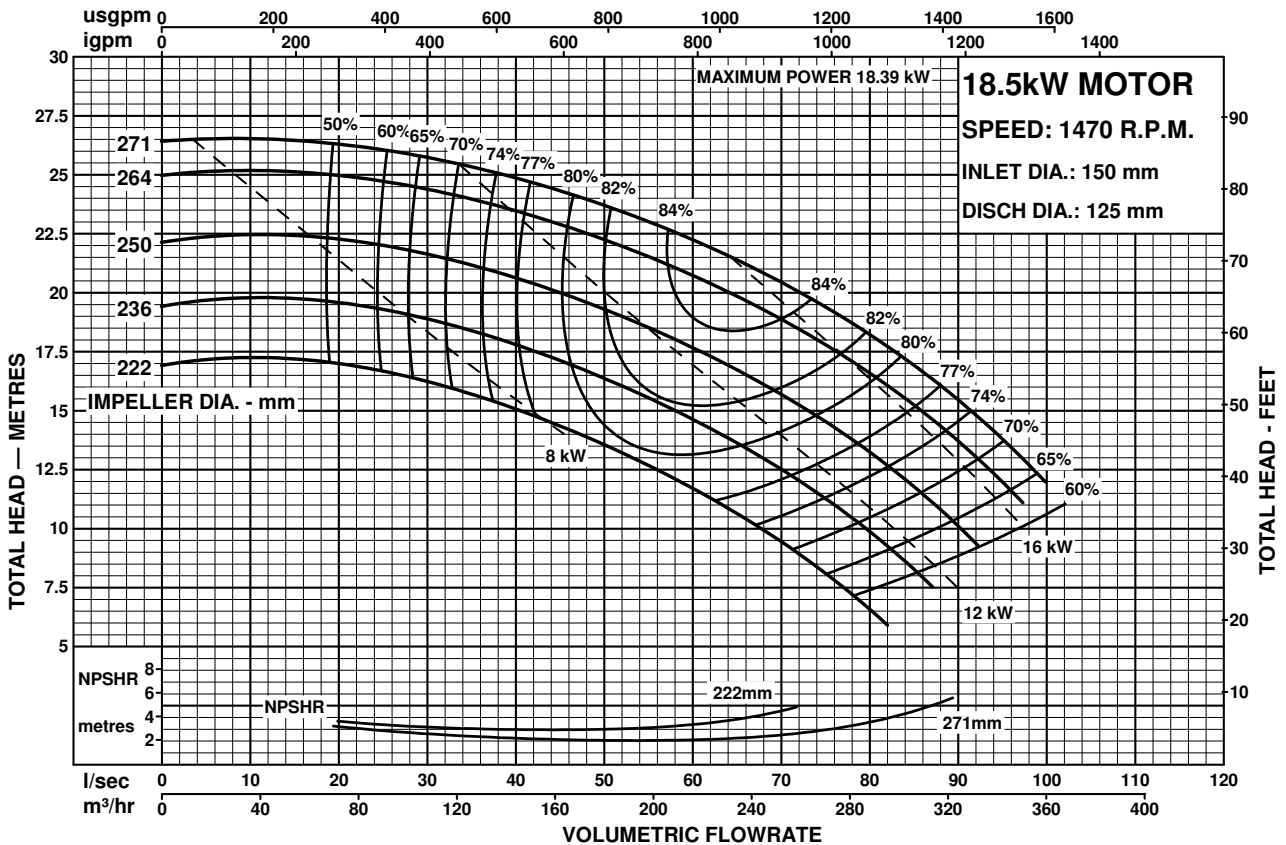

Performance to AS2417 Grade 2 for clean, cold water only.





# PENTAIR STARLINE

MOTORPUMPS

50Hz PERFORMANCE

## MODEL 150x125-250

CENTRIFUGAL PUMP PERFORMANCE DATA

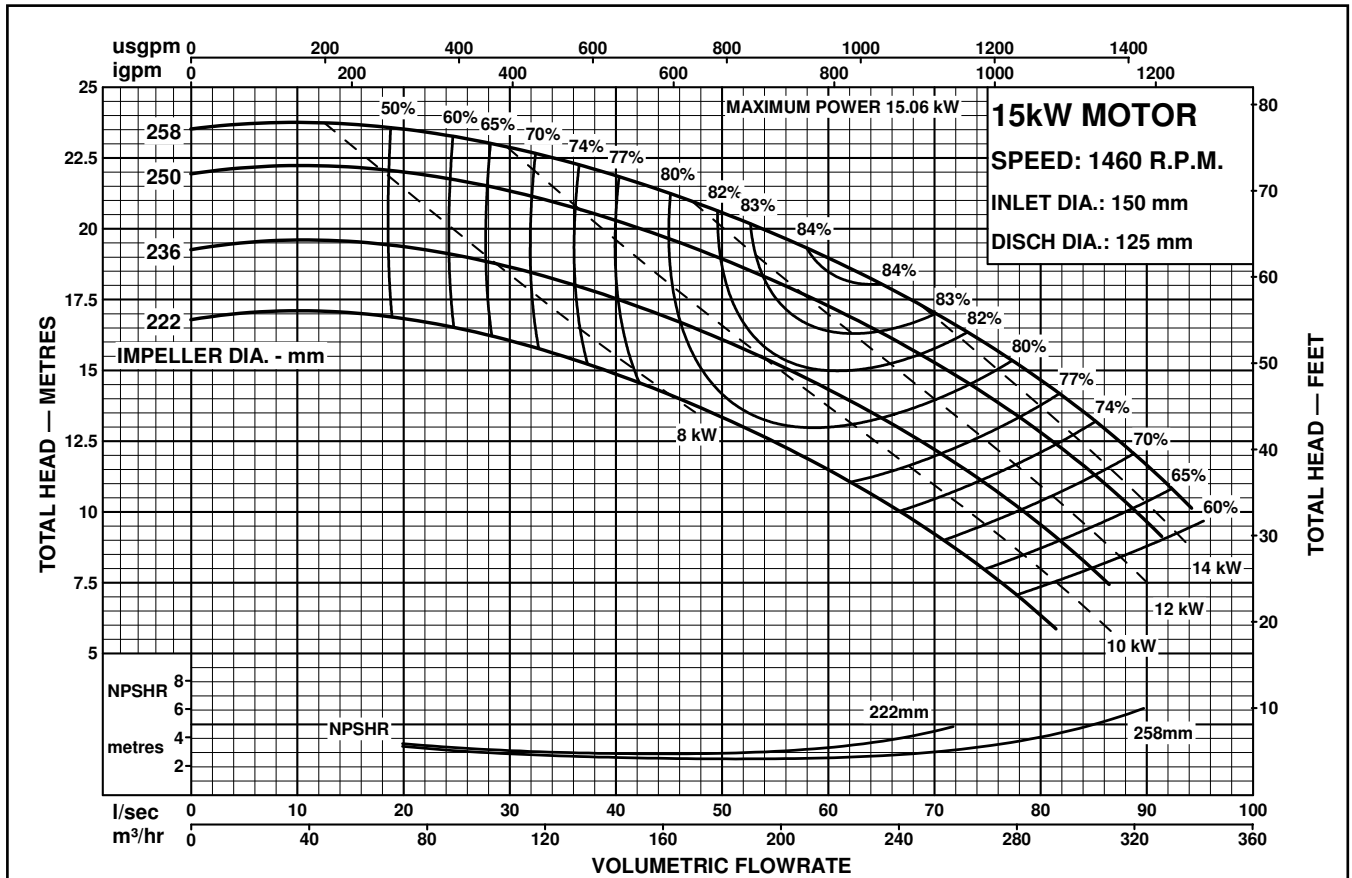

Performance to AS2417 Grade 2 for clean, cold water only.

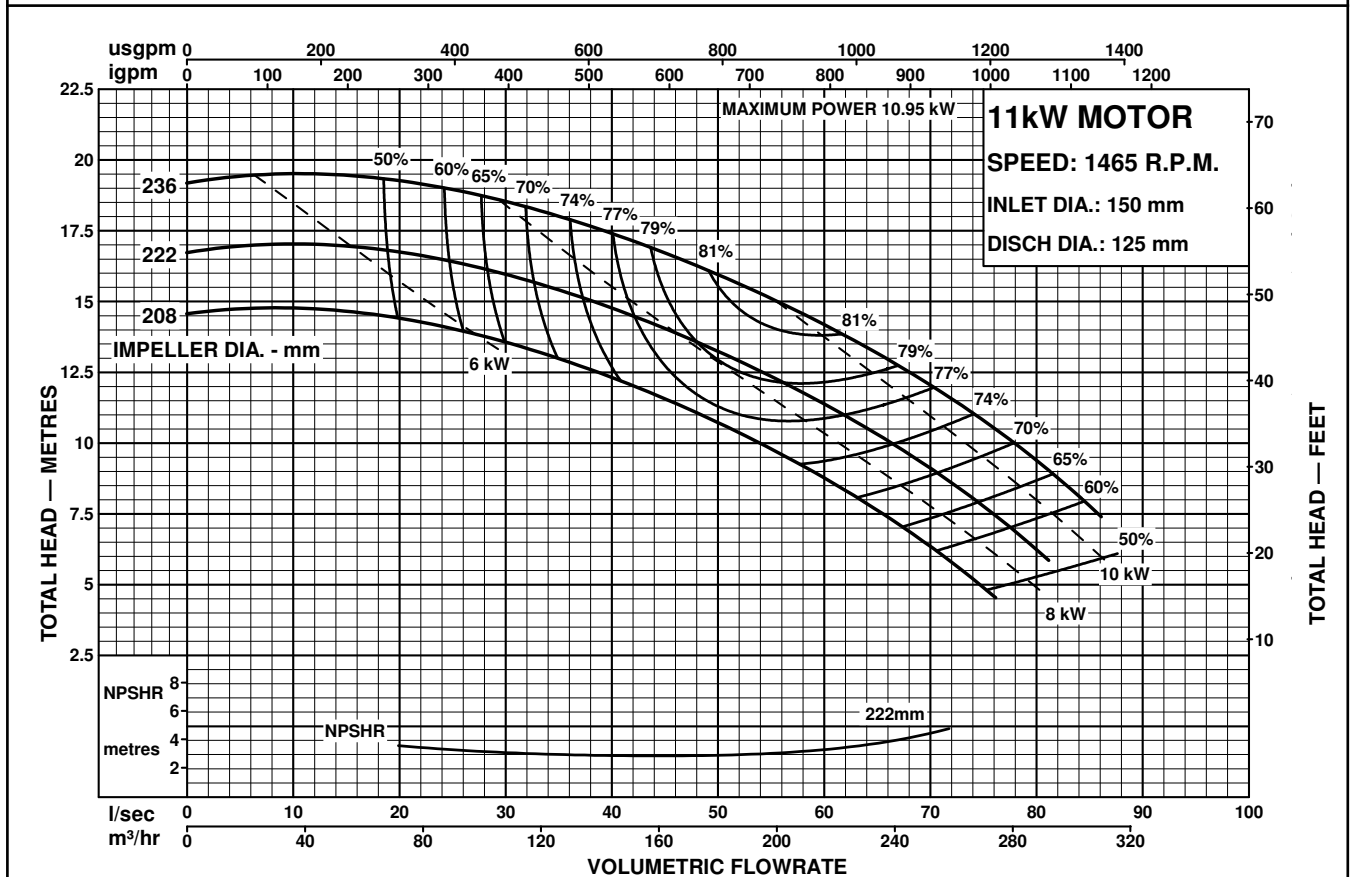

Performance to AS2417 Grade 2 for clean, cold water only.





# PENTAIR STARLINE

MOTORPUMPS  
50Hz PERFORMANCE

MODEL  
**150x125-315**

CENTRIFUGAL PUMP PERFORMANCE DATA

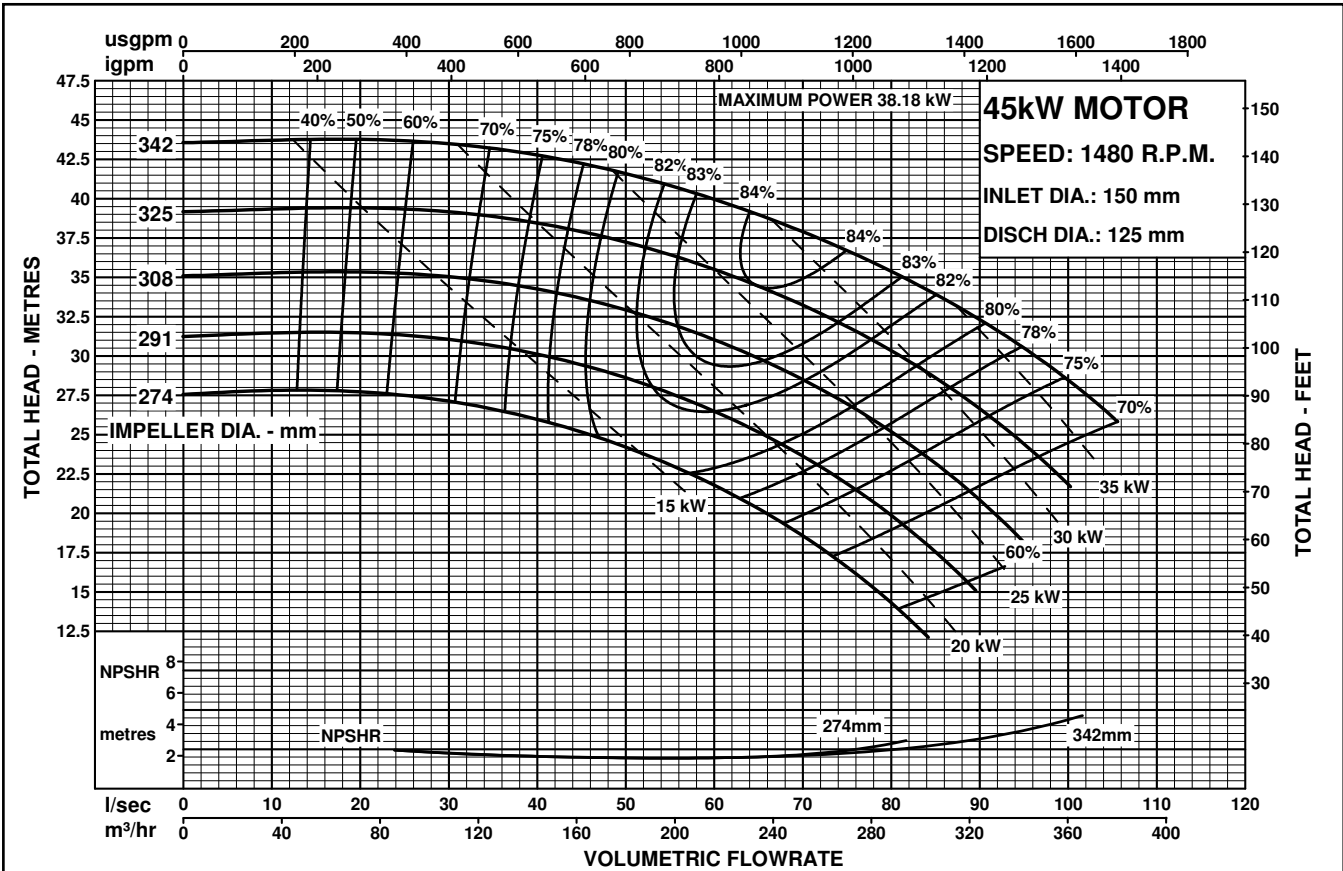

Performance to AS2417 Grade 2 for clean, cold water only.

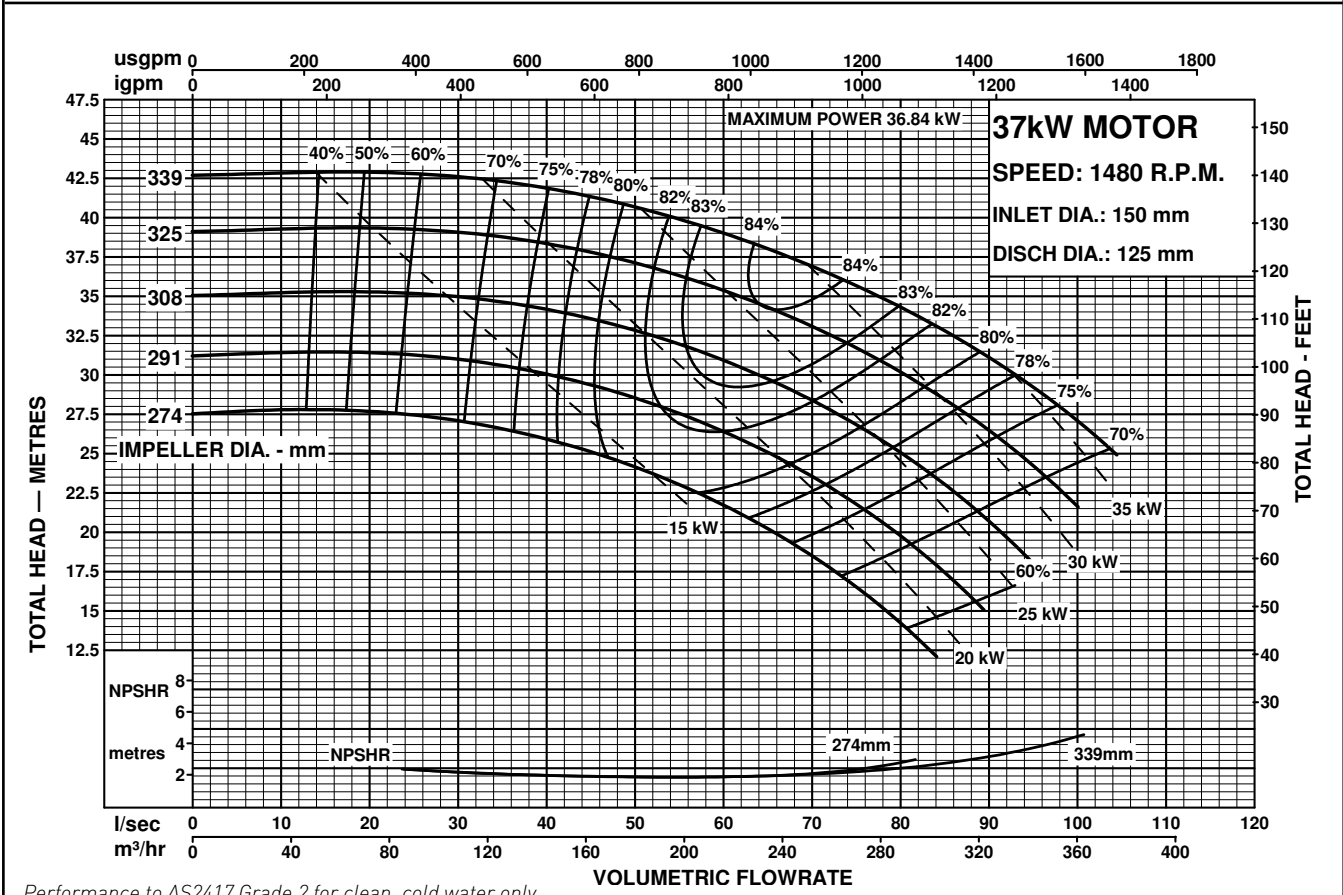

Performance to AS2417 Grade 2 for clean, cold water only.







# PENTAIR STARLINE

MOTORPUMPS

50Hz PERFORMANCE

MODEL  
**150x125-315**

CENTRIFUGAL PUMP PERFORMANCE DATA

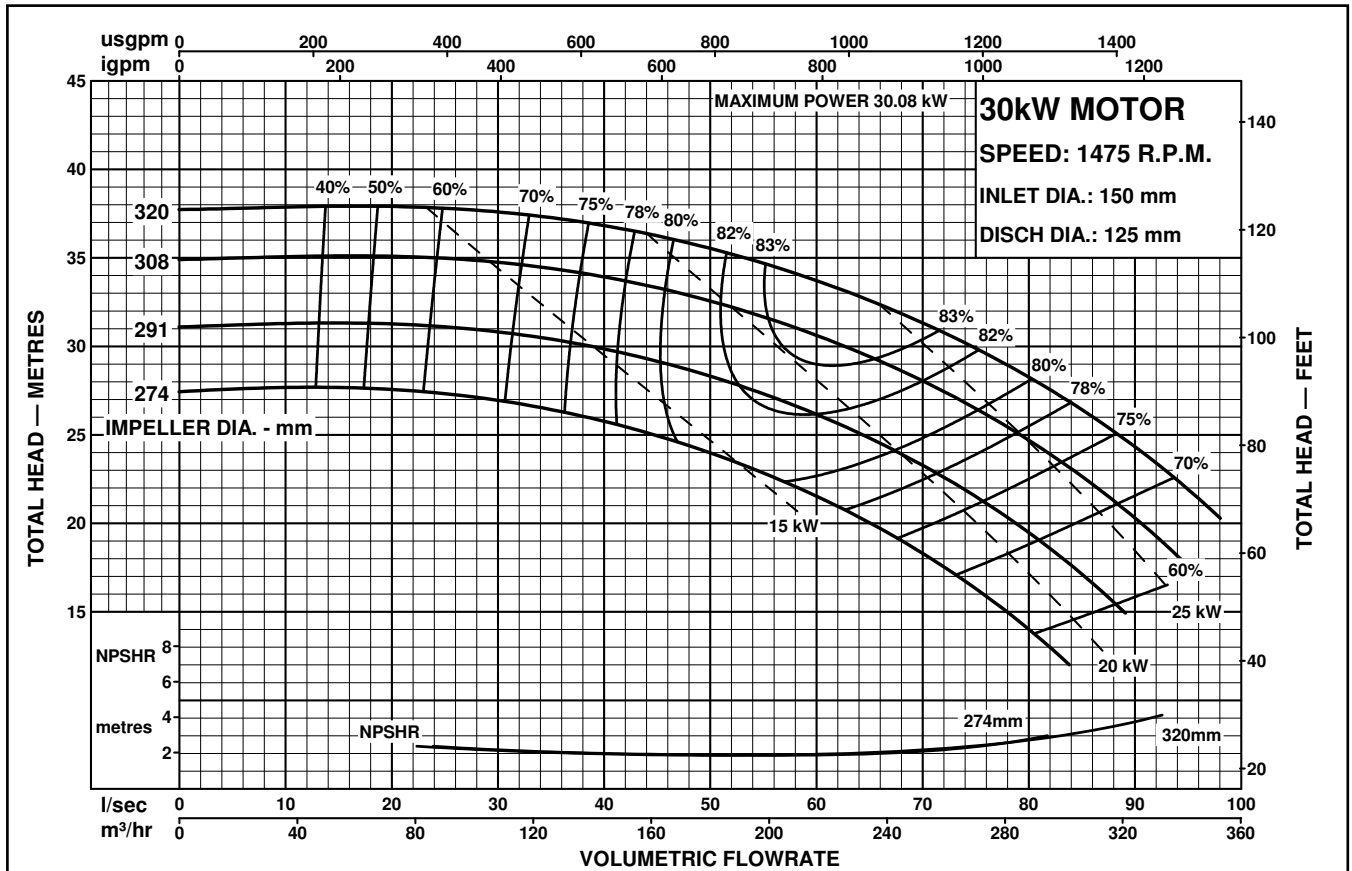

Performance to AS2417 Grade 2 for clean, cold water only.

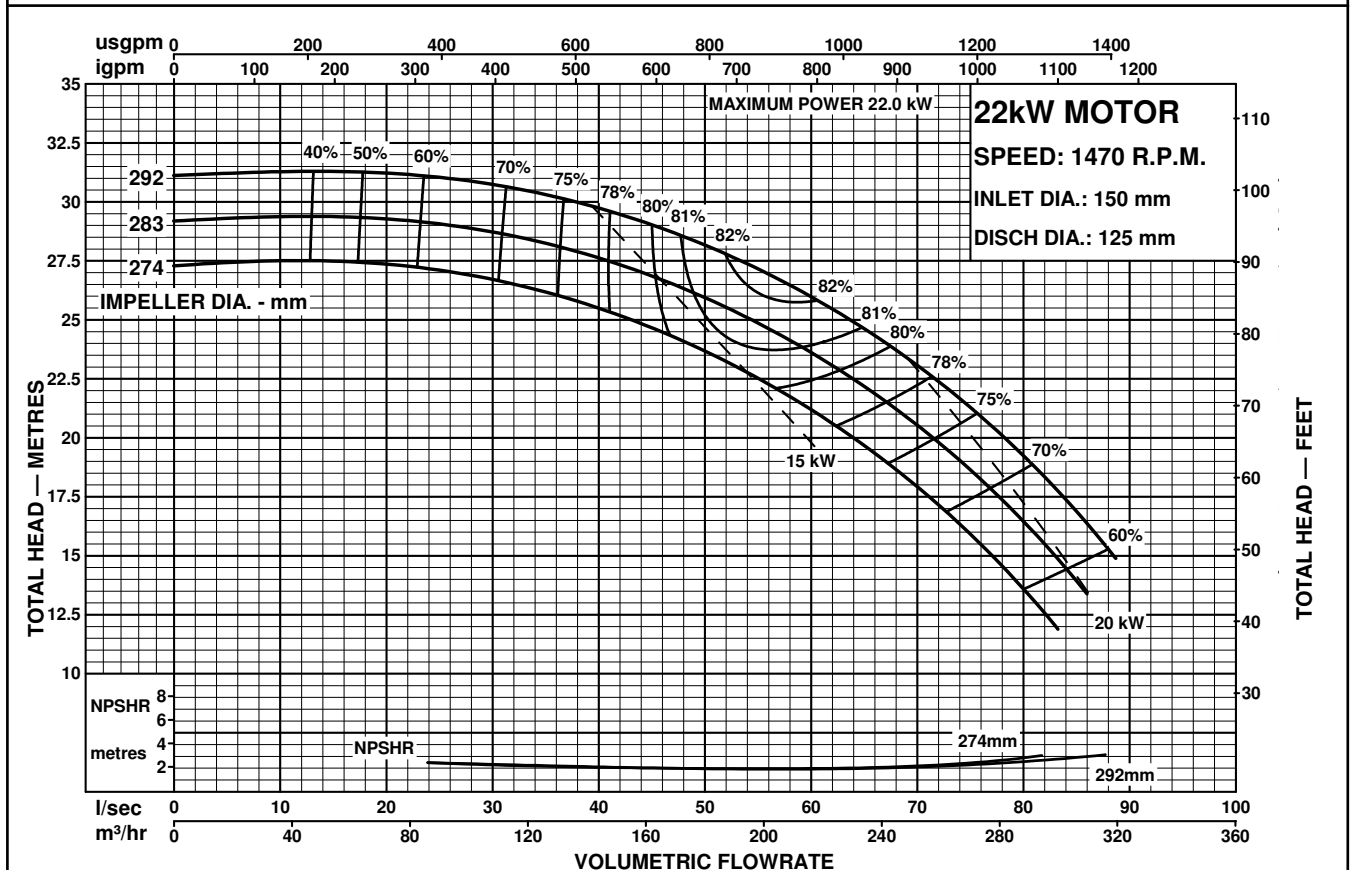

Performance to AS2417 Grade 2 for clean, cold water only.





# PENTAIR STARLINE

MOTORPUMPS  
50Hz PERFORMANCE

MODEL  
**150x125-315**

CENTRIFUGAL PUMP PERFORMANCE DATA

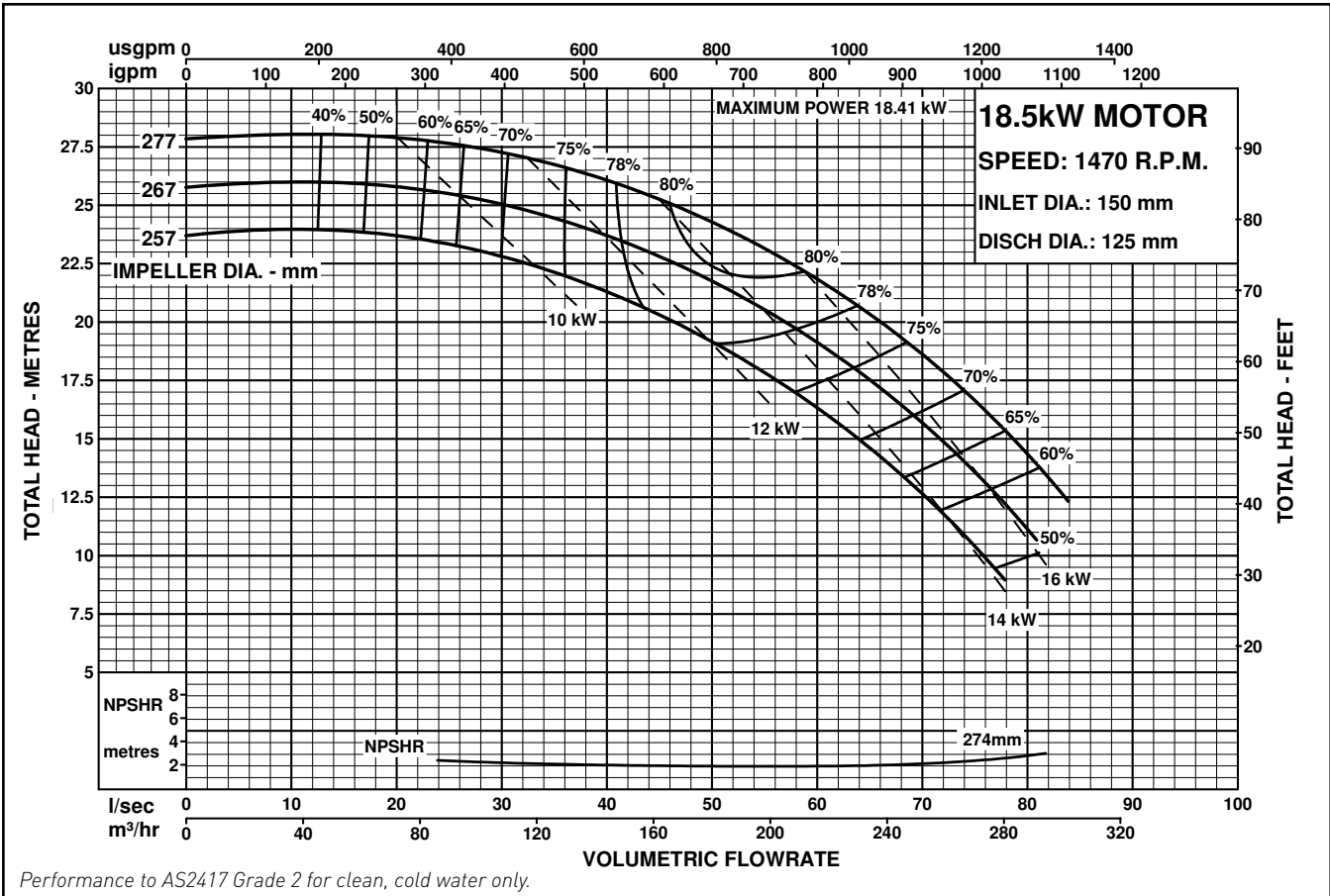



# PENTAIR STARLINE

MOTORPUMPS  
50Hz PERFORMANCE

MODEL  
**150x125-400**

CENTRIFUGAL PUMP PERFORMANCE DATA

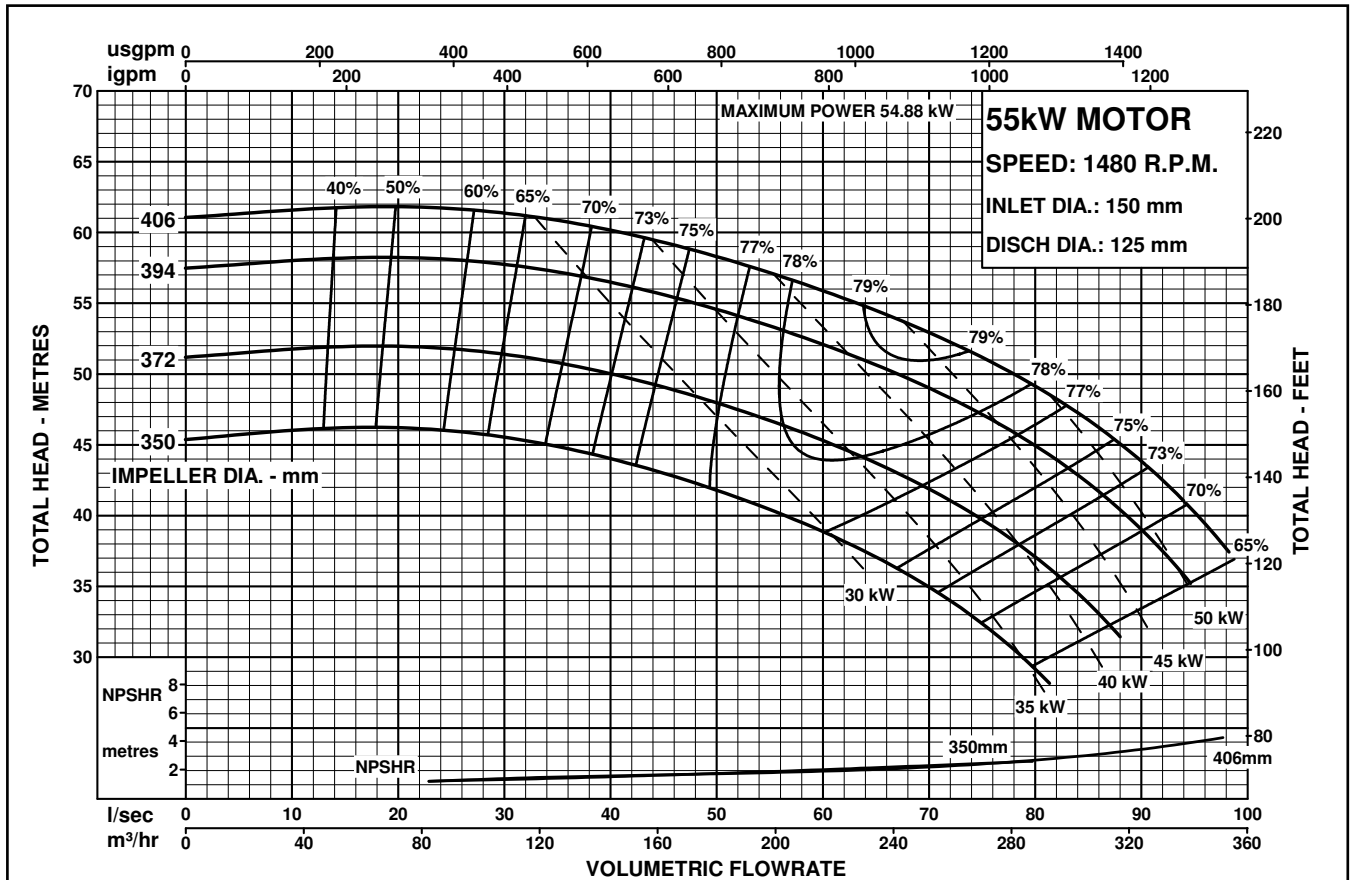

Performance to AS2417 Grade 2 for clean, cold water only.

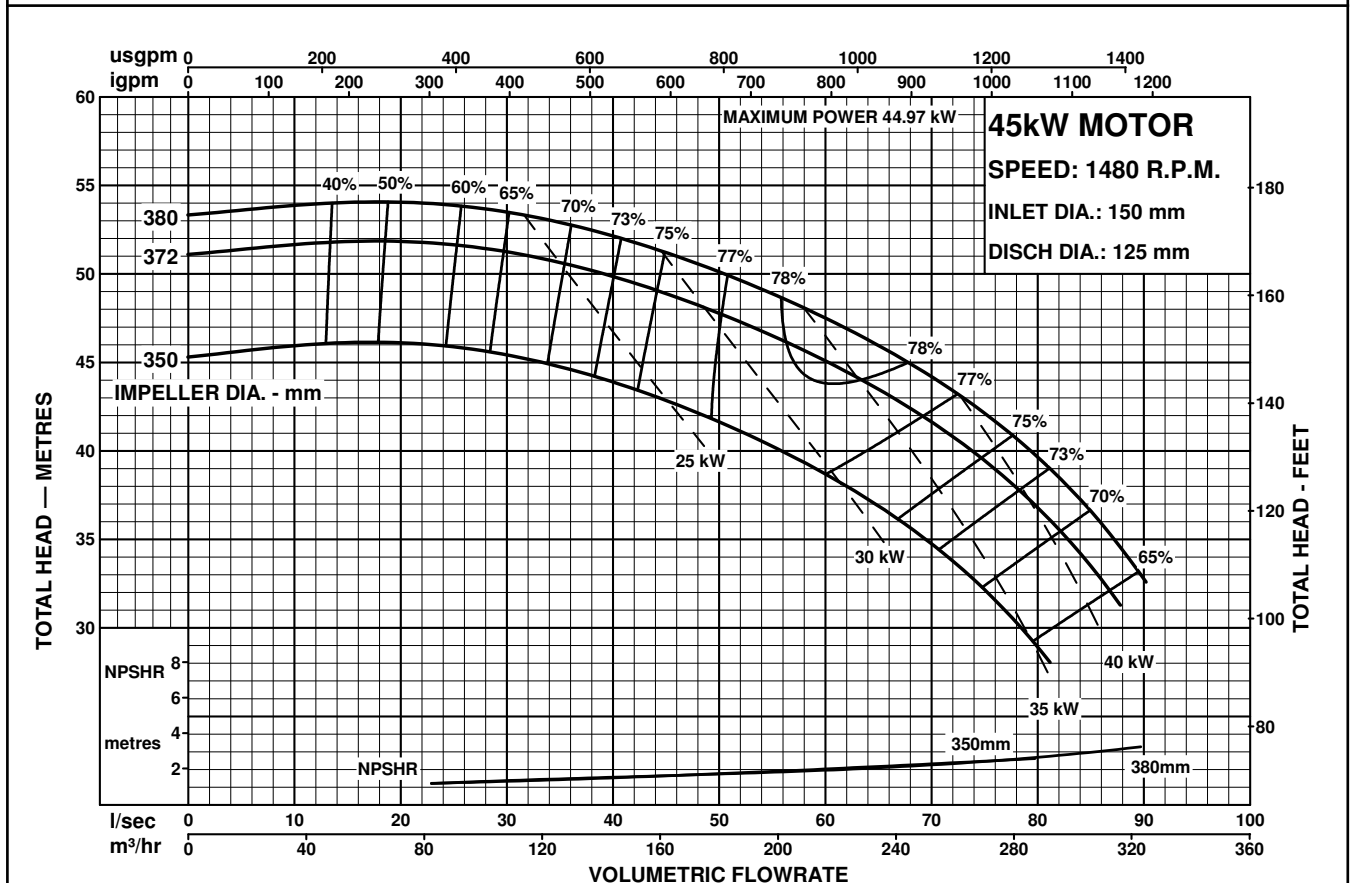

Performance to AS2417 Grade 2 for clean, cold water only.





# PENTAIR STARLINE

MOTORPUMPS  
50Hz PERFORMANCE

MODEL  
**150x125-400**

CENTRIFUGAL PUMP PERFORMANCE DATA

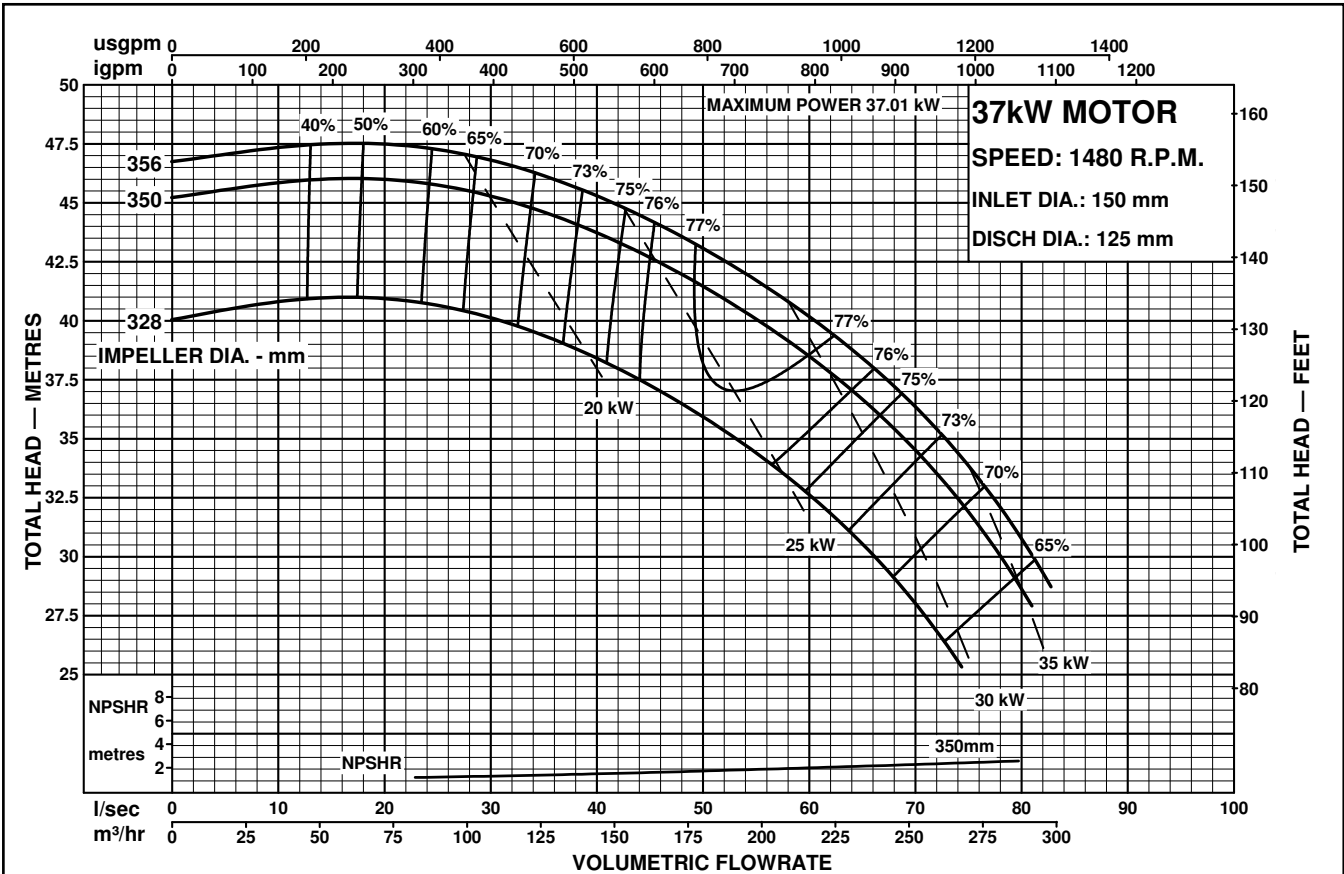

Performance to AS2417 Grade 2 for clean, cold water only.





# PENTAIR STARLINE

MOTORPUMPS

50Hz PERFORMANCE

## MODEL 150x125-500

CENTRIFUGAL PUMP PERFORMANCE DATA

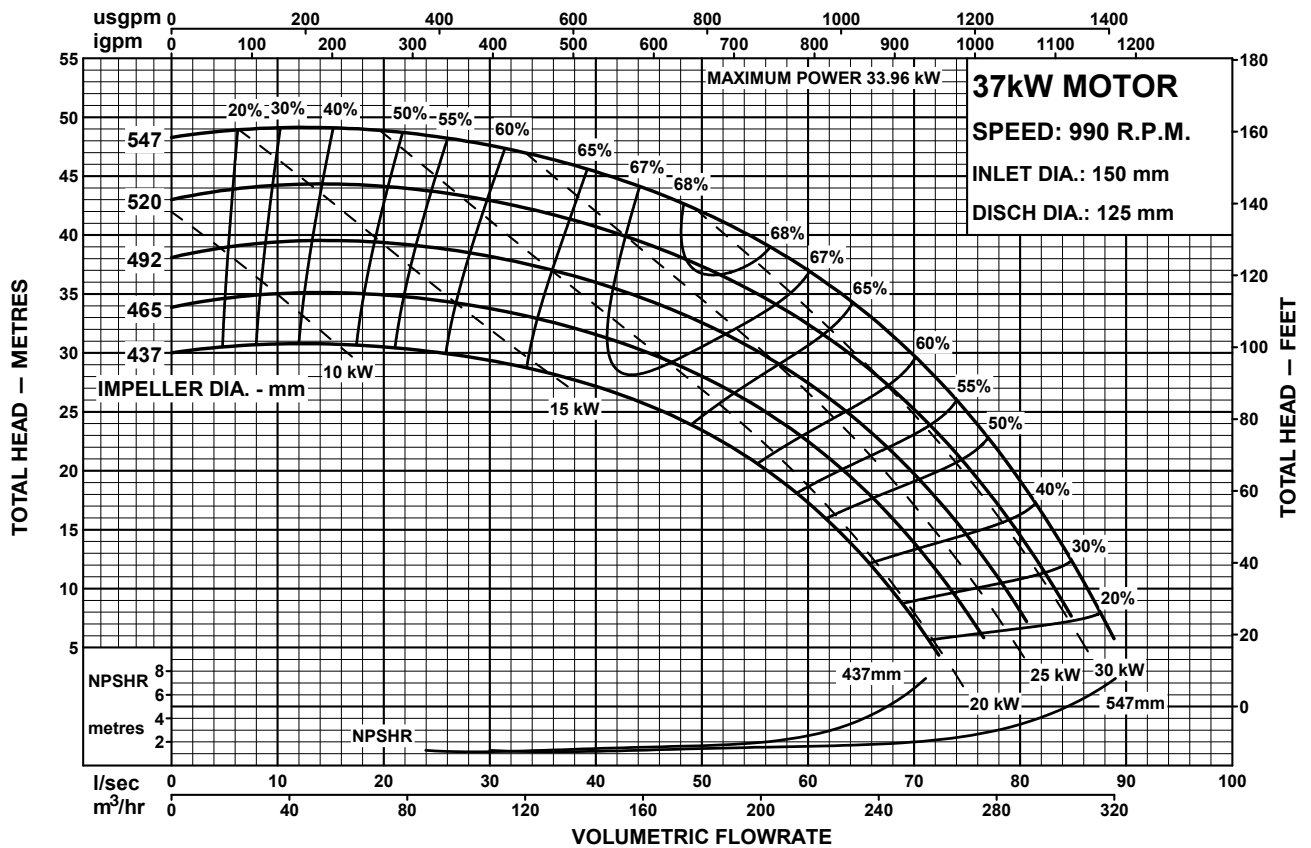

Performance to AS2417 Grade 2 for clean, cold water only.

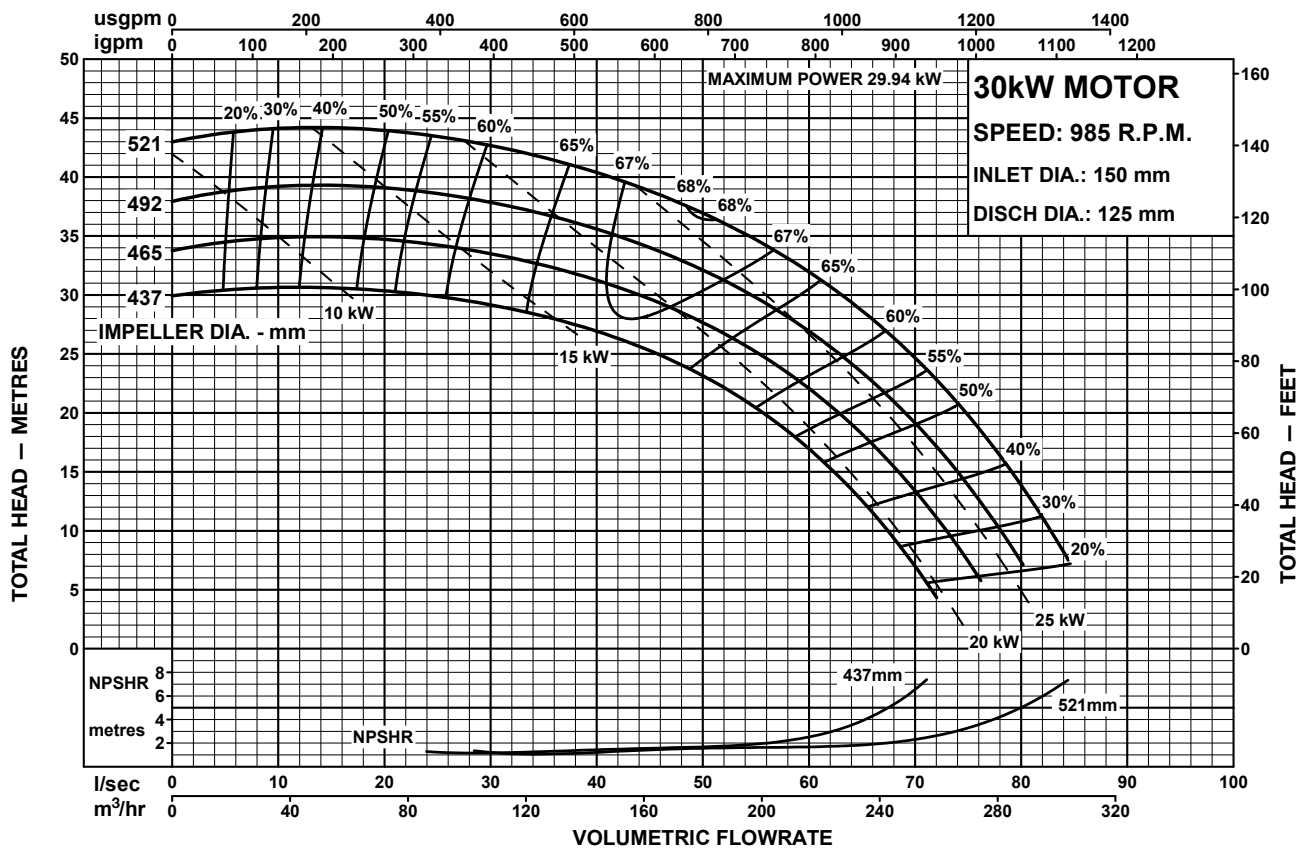

Performance to AS2417 Grade 2 for clean, cold water only.





# PENTAIR STARLINE

MOTORPUMPS  
50Hz PERFORMANCE

MODEL  
**150x125-500**

CENTRIFUGAL PUMP PERFORMANCE DATA

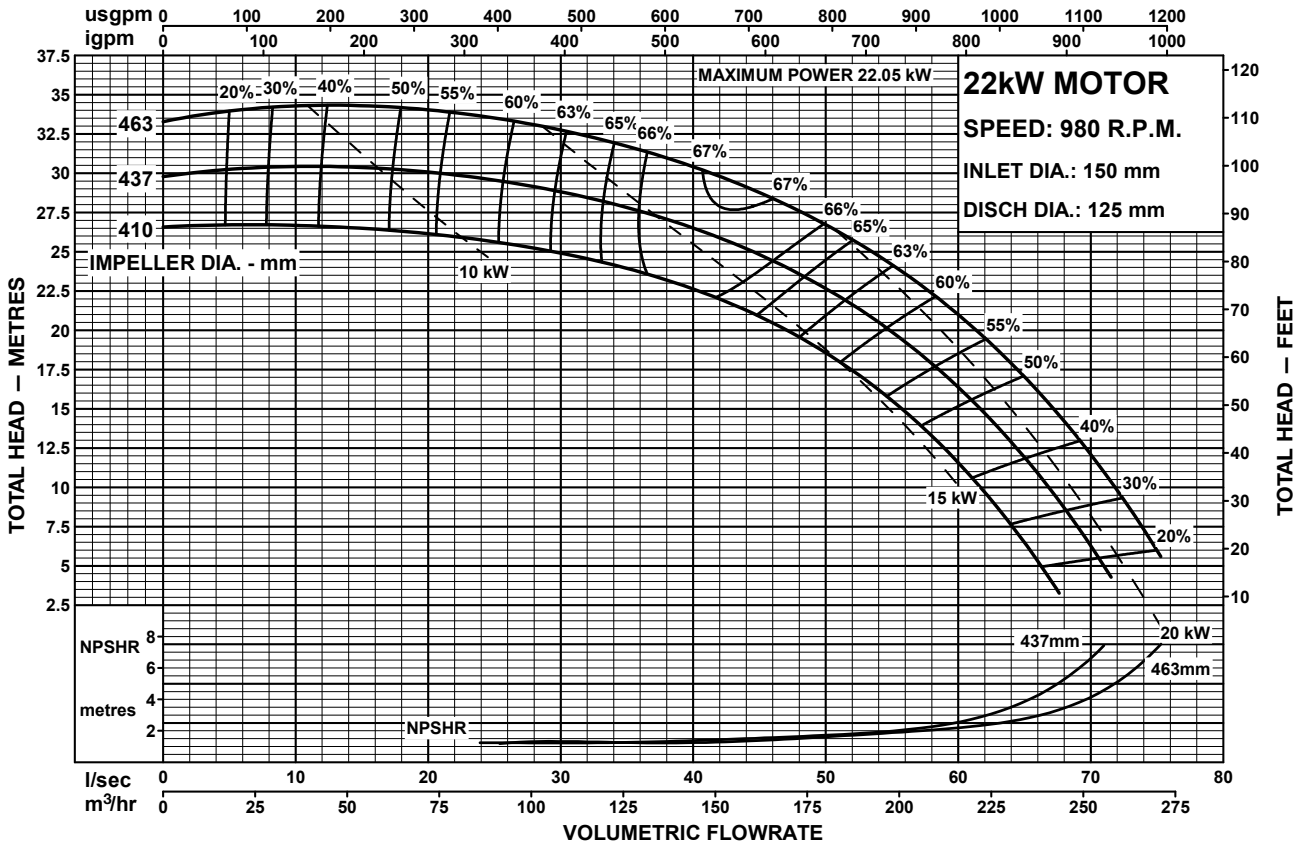

Performance to AS2417 Grade 2 for clean, cold water only.



# PENTAIR STARLINE

MOTORPUMPS

50Hz PERFORMANCE

## MODEL 150x125-500

CENTRIFUGAL PUMP PERFORMANCE DATA

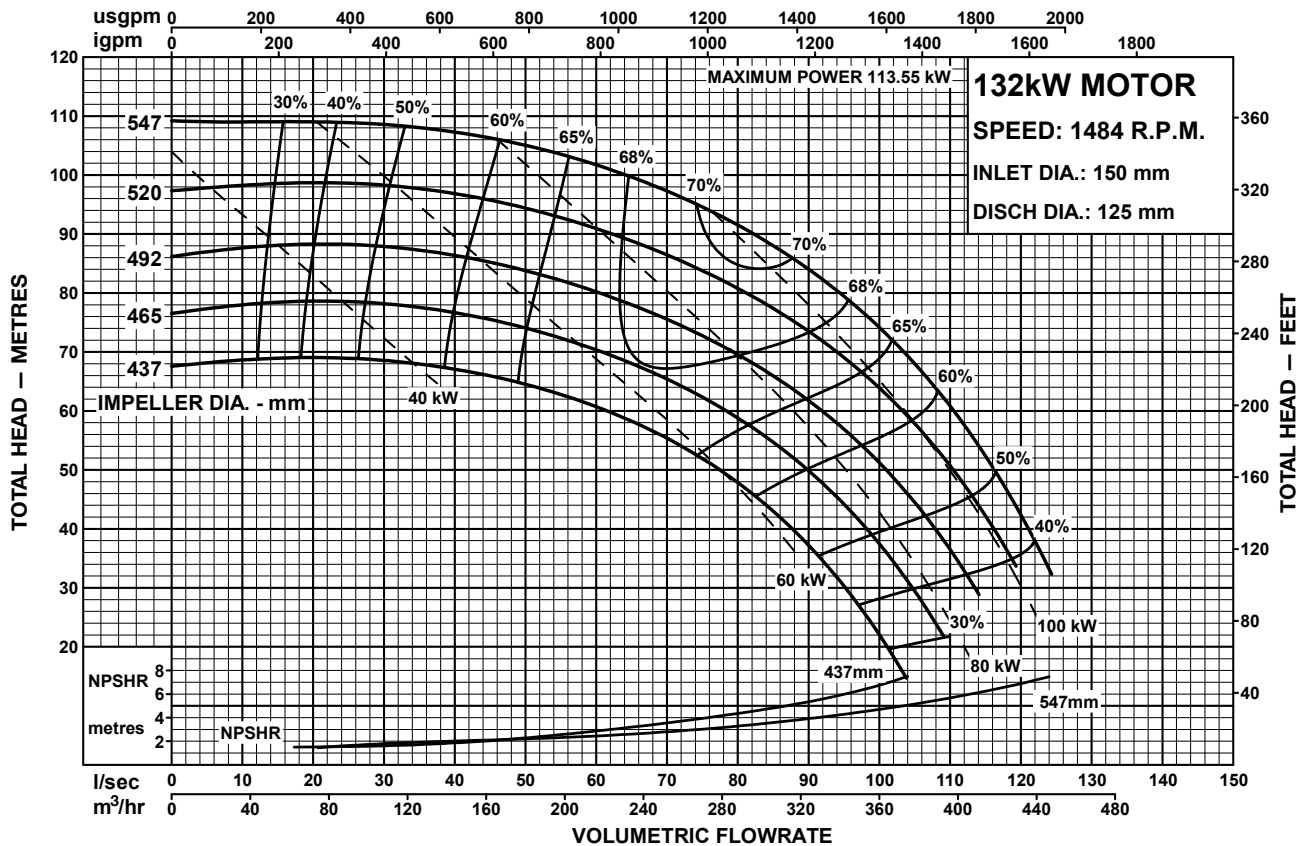

Performance to AS2417 Grade 2 for clean, cold water only.

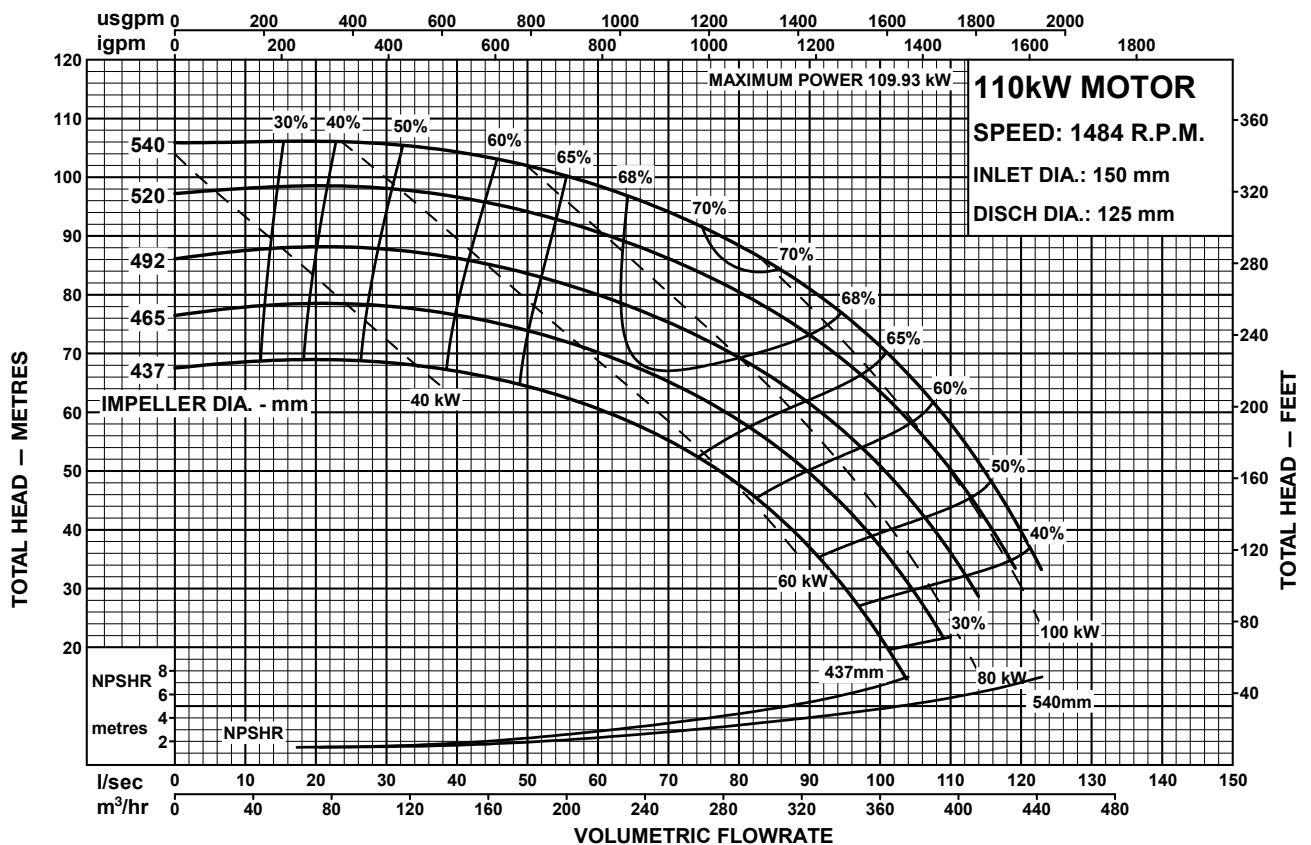

Performance to AS2417 Grade 2 for clean, cold water only.





# PENTAIR STARLINE

MOTORPUMPS  
50Hz PERFORMANCE

MODEL  
**150x125-500**

CENTRIFUGAL PUMP PERFORMANCE DATA

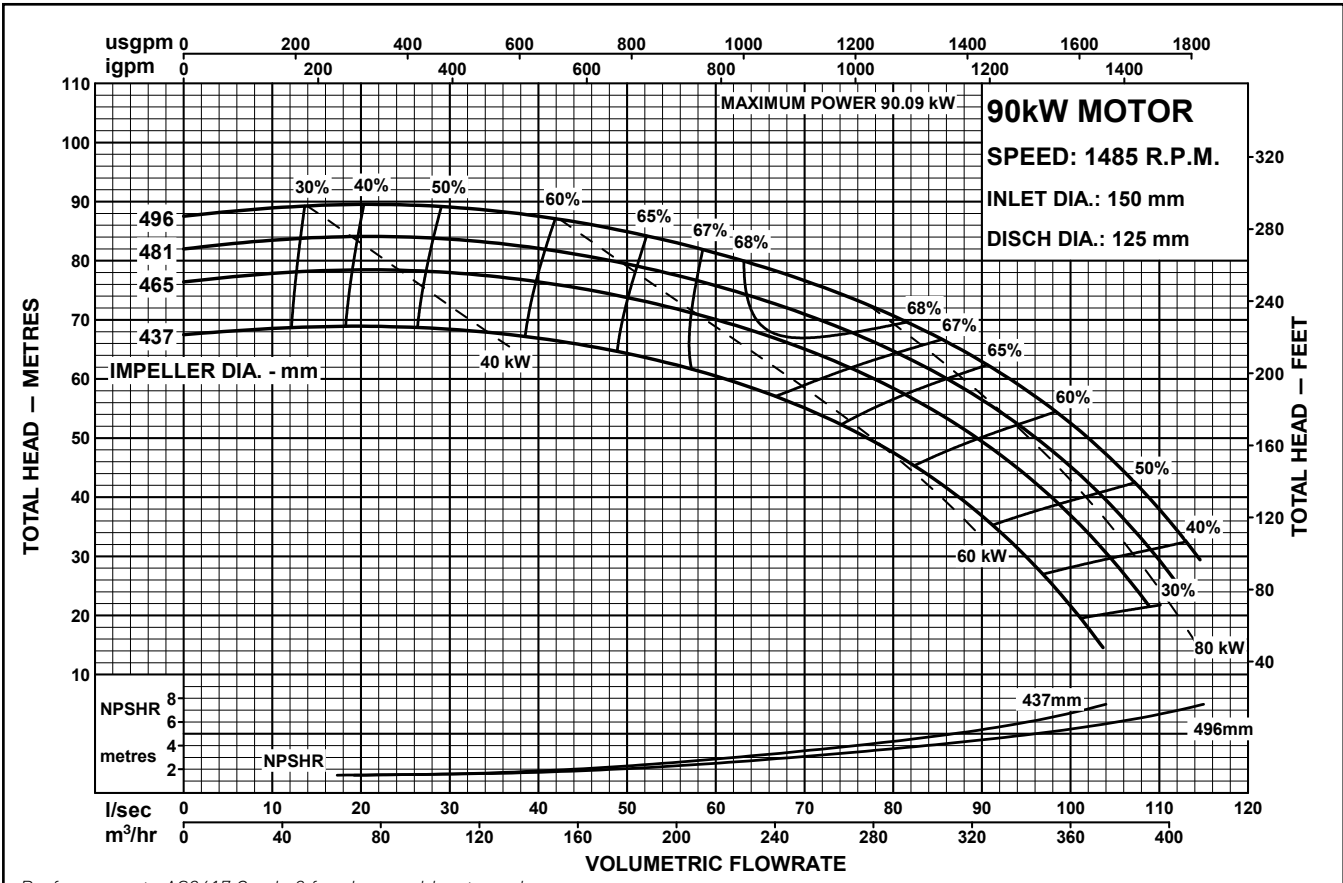

Performance to AS2417 Grade 2 for clean, cold water only.

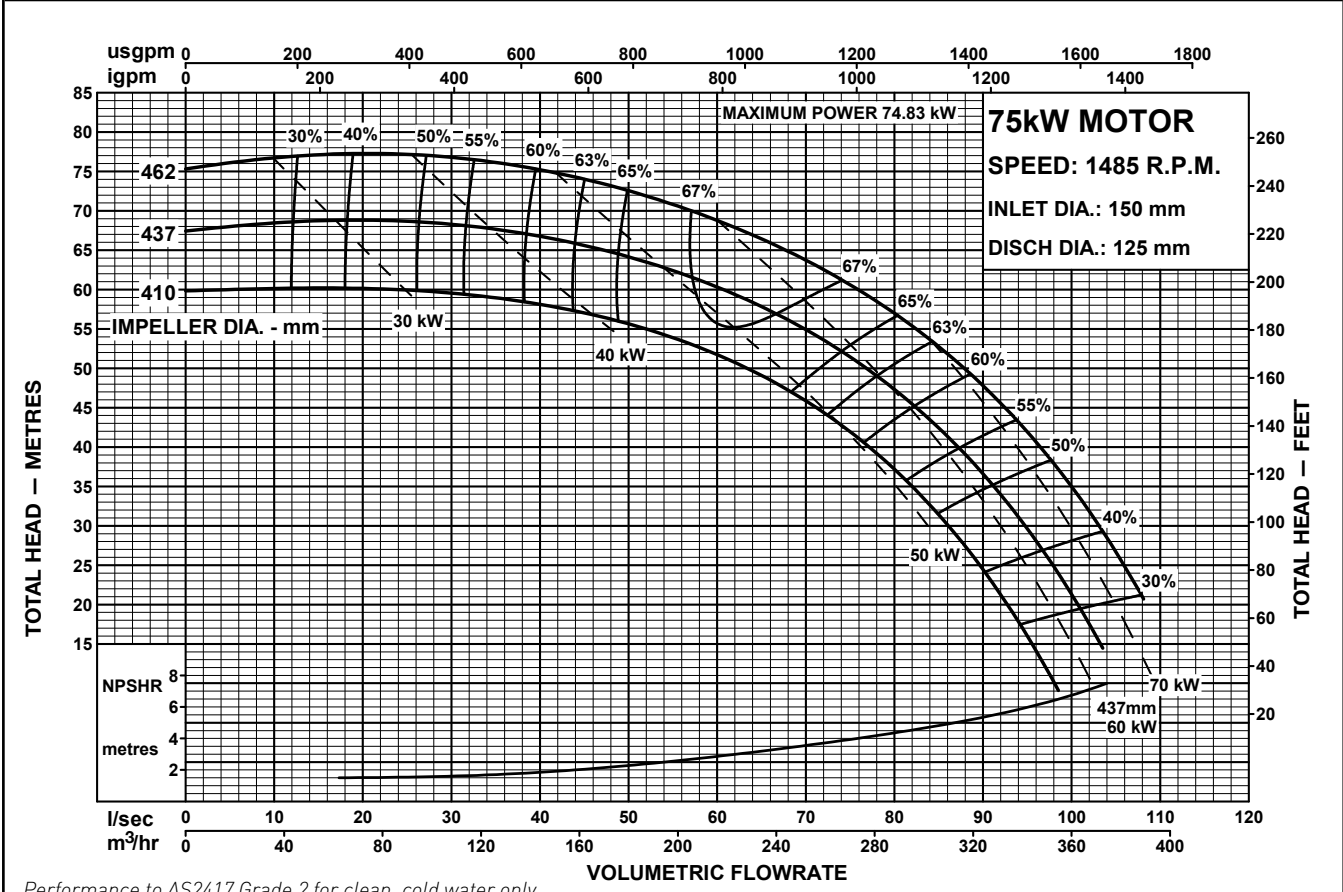

Performance to AS2417 Grade 2 for clean, cold water only.







# PENTAIR STARLINE

MOTORPUMPS

50Hz PERFORMANCE

## MODEL 200x150-315

CENTRIFUGAL PUMP PERFORMANCE DATA

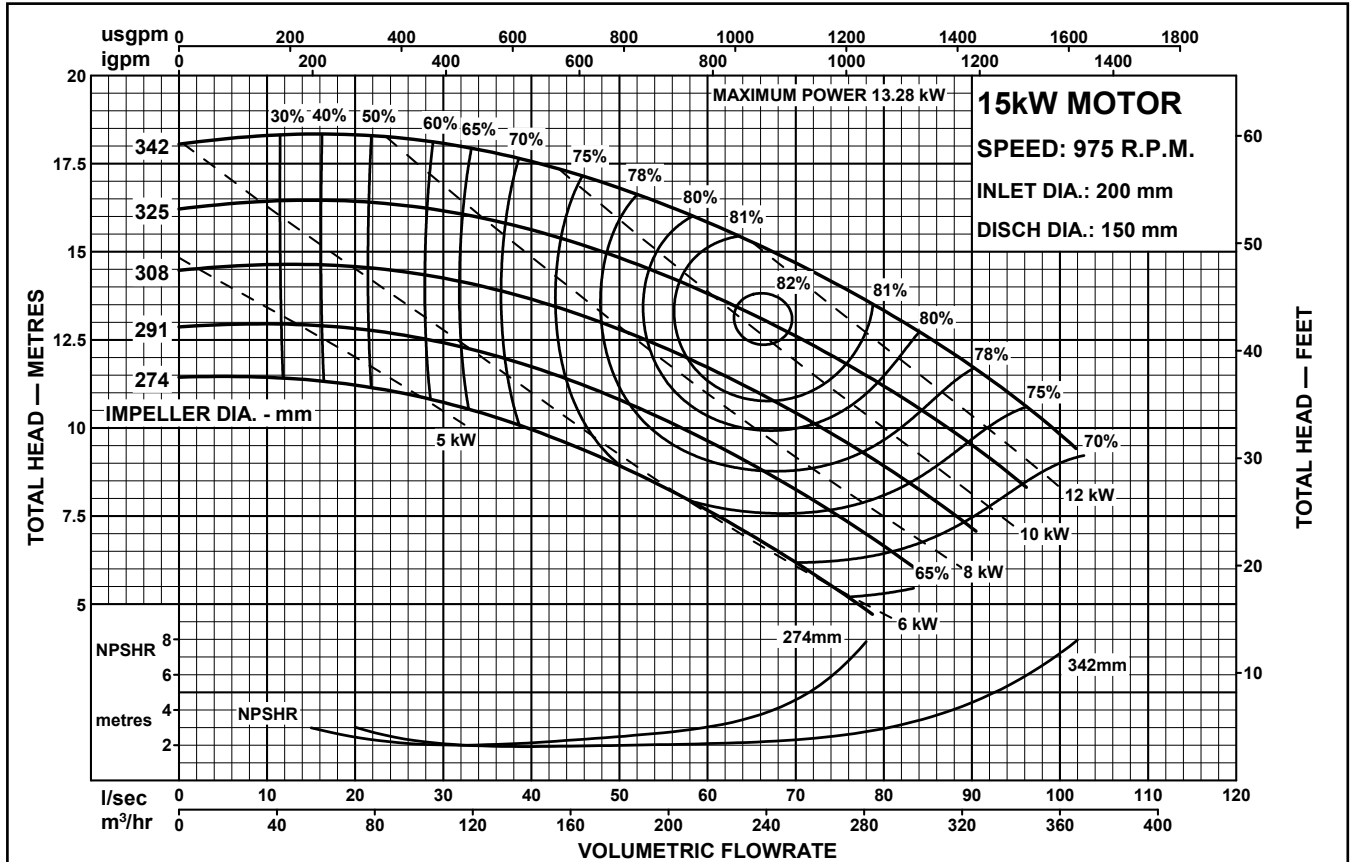

Performance to AS2417 Grade 2 for clean, cold water only.

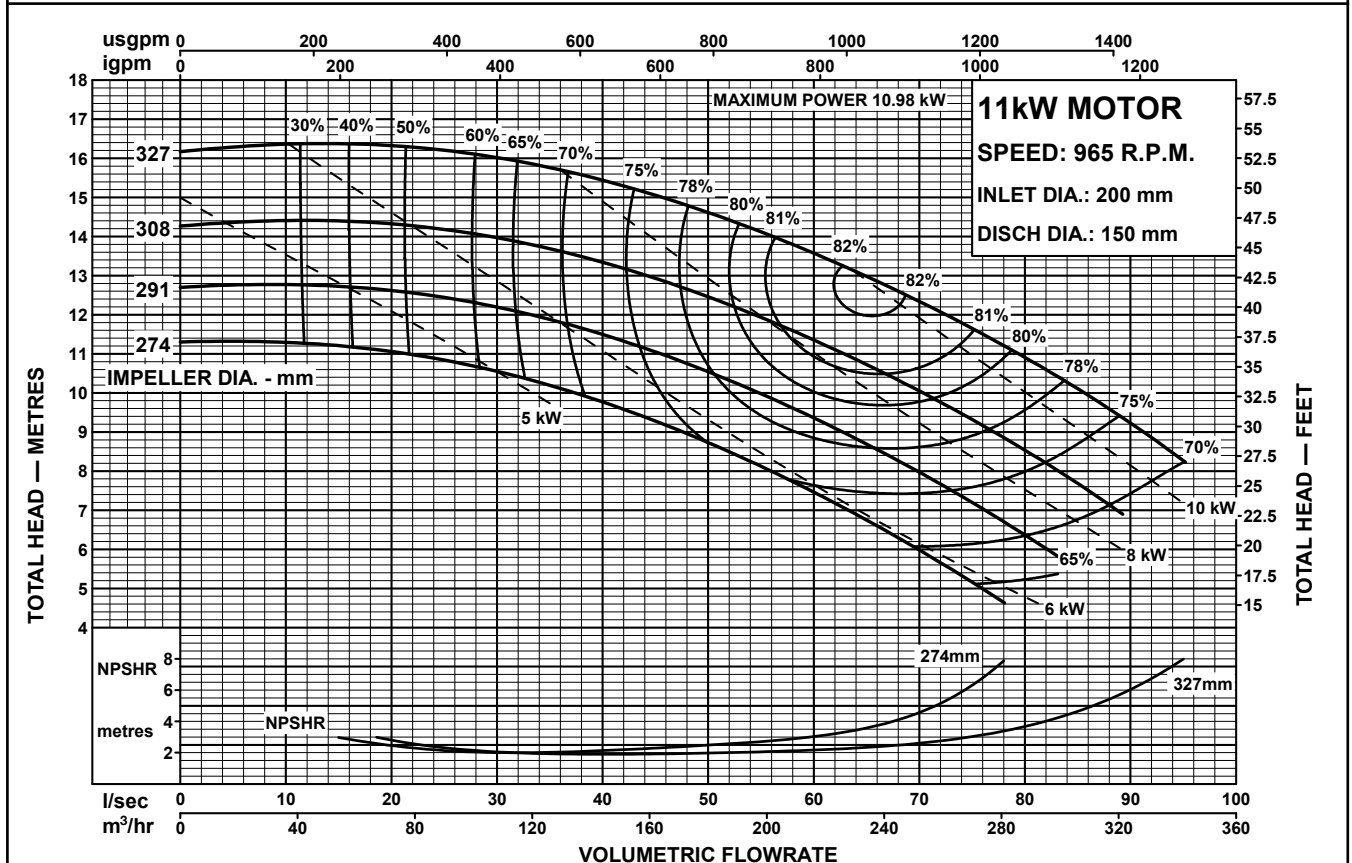

Performance to AS2417 Grade 2 for clean, cold water only.





# PENTAIR STARLINE

MOTORPUMPS  
50Hz PERFORMANCE

MODEL  
**200x150-315**

CENTRIFUGAL PUMP PERFORMANCE DATA

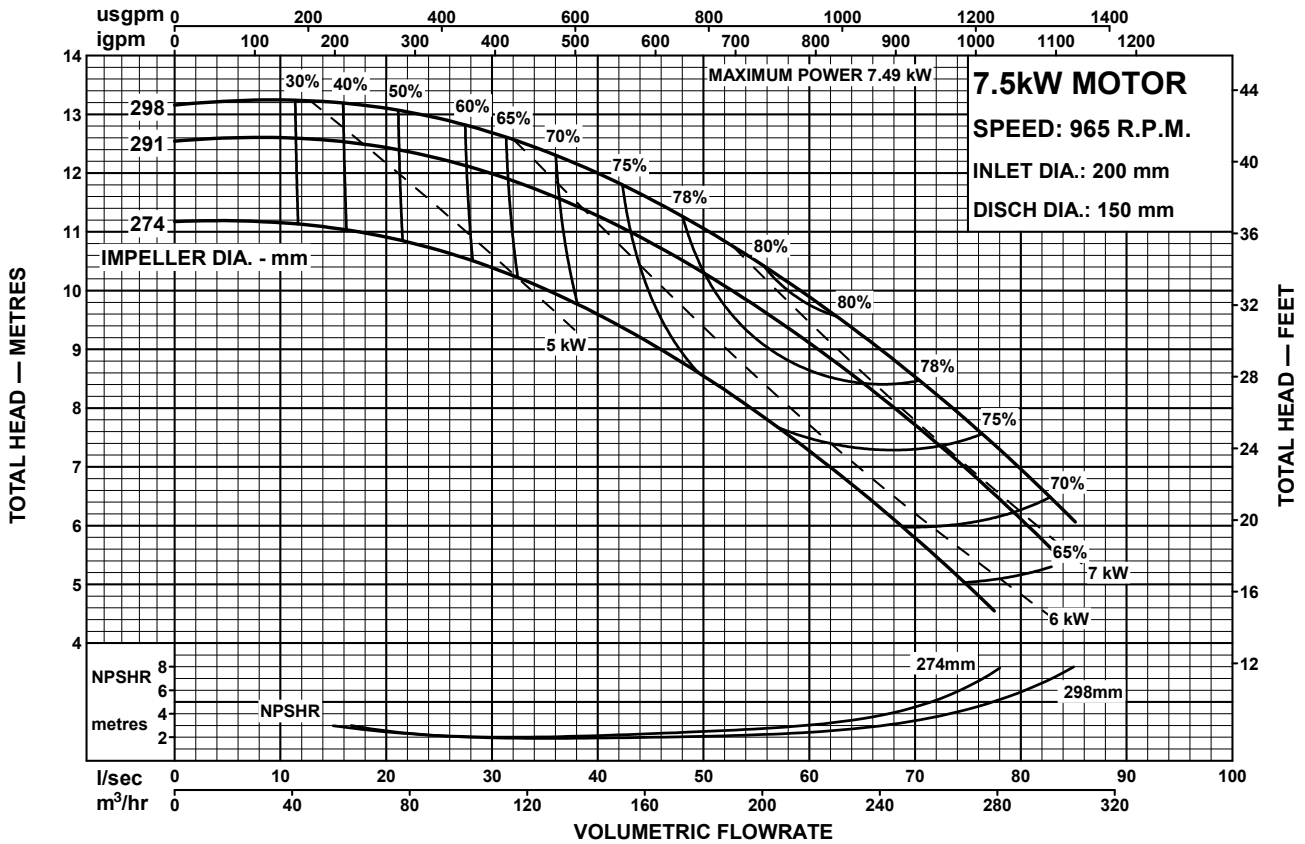

Performance to AS2417 Grade 2 for clean, cold water only.





# PENTAIR STARLINE

MOTORPUMPS

50Hz PERFORMANCE

## MODEL 200x150-315

CENTRIFUGAL PUMP PERFORMANCE DATA

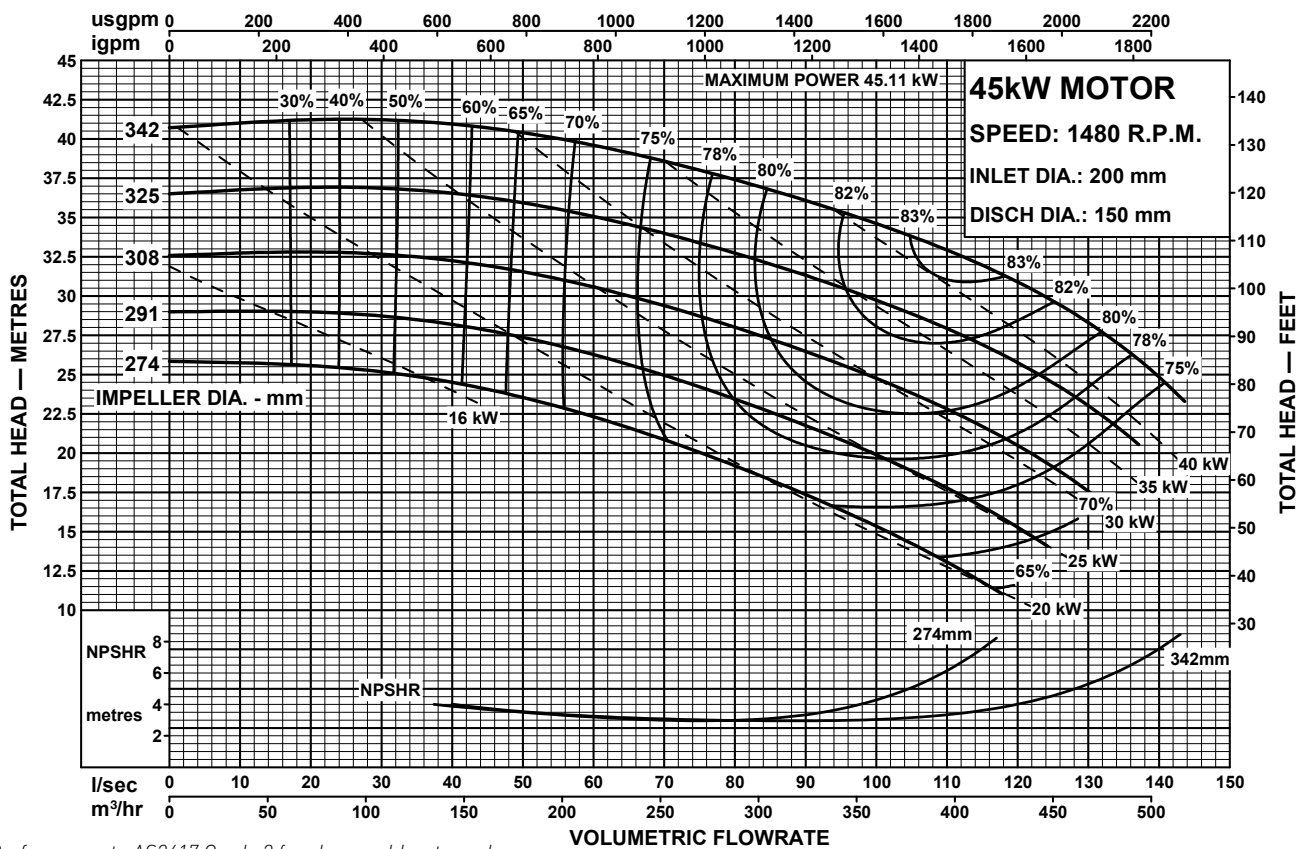

Performance to AS2417 Grade 2 for clean, cold water only.

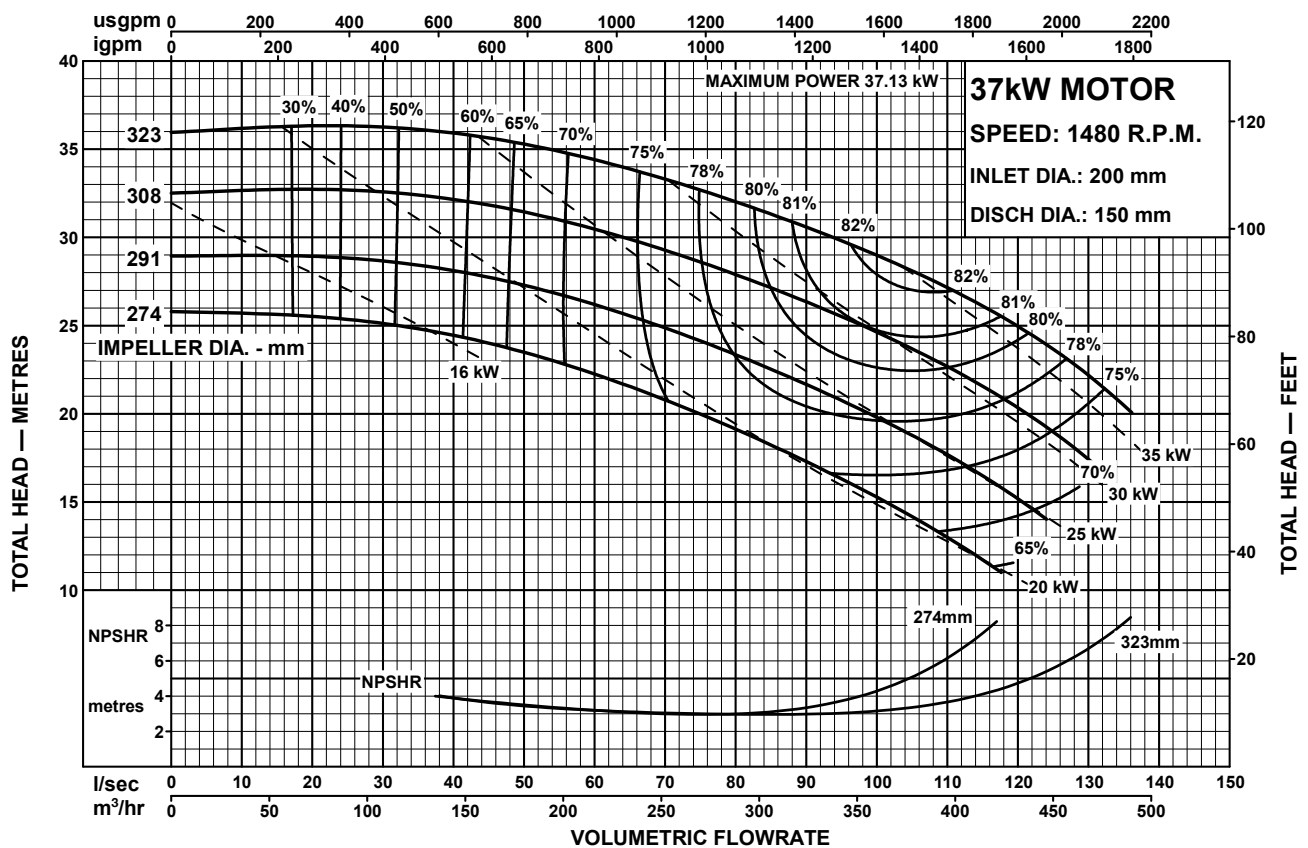

Performance to AS2417 Grade 2 for clean, cold water only.





# PENTAIR STARLINE

MOTORPUMPS  
50Hz PERFORMANCE

MODEL  
**200x150-315**

CENTRIFUGAL PUMP PERFORMANCE DATA

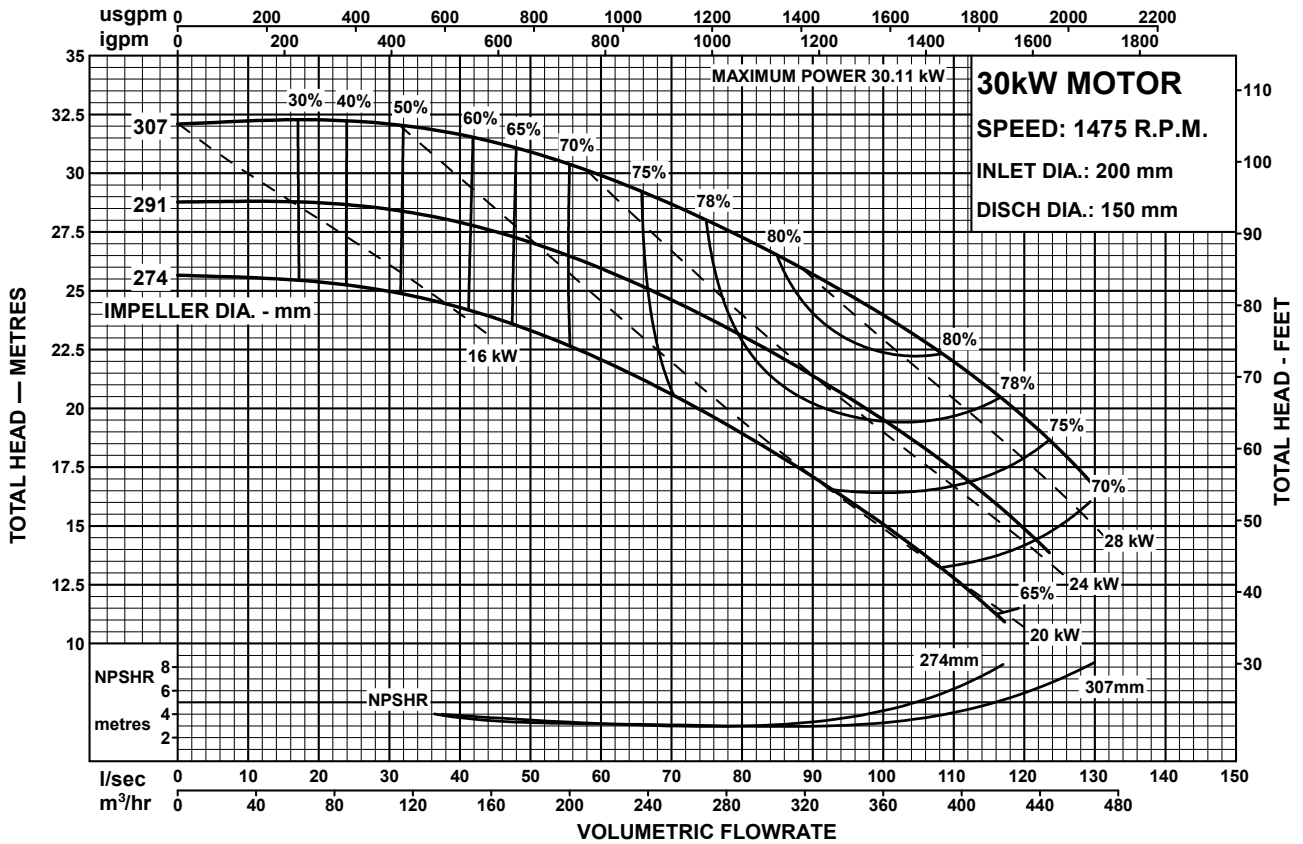

Performance to AS2417 Grade 2 for clean, cold water only.

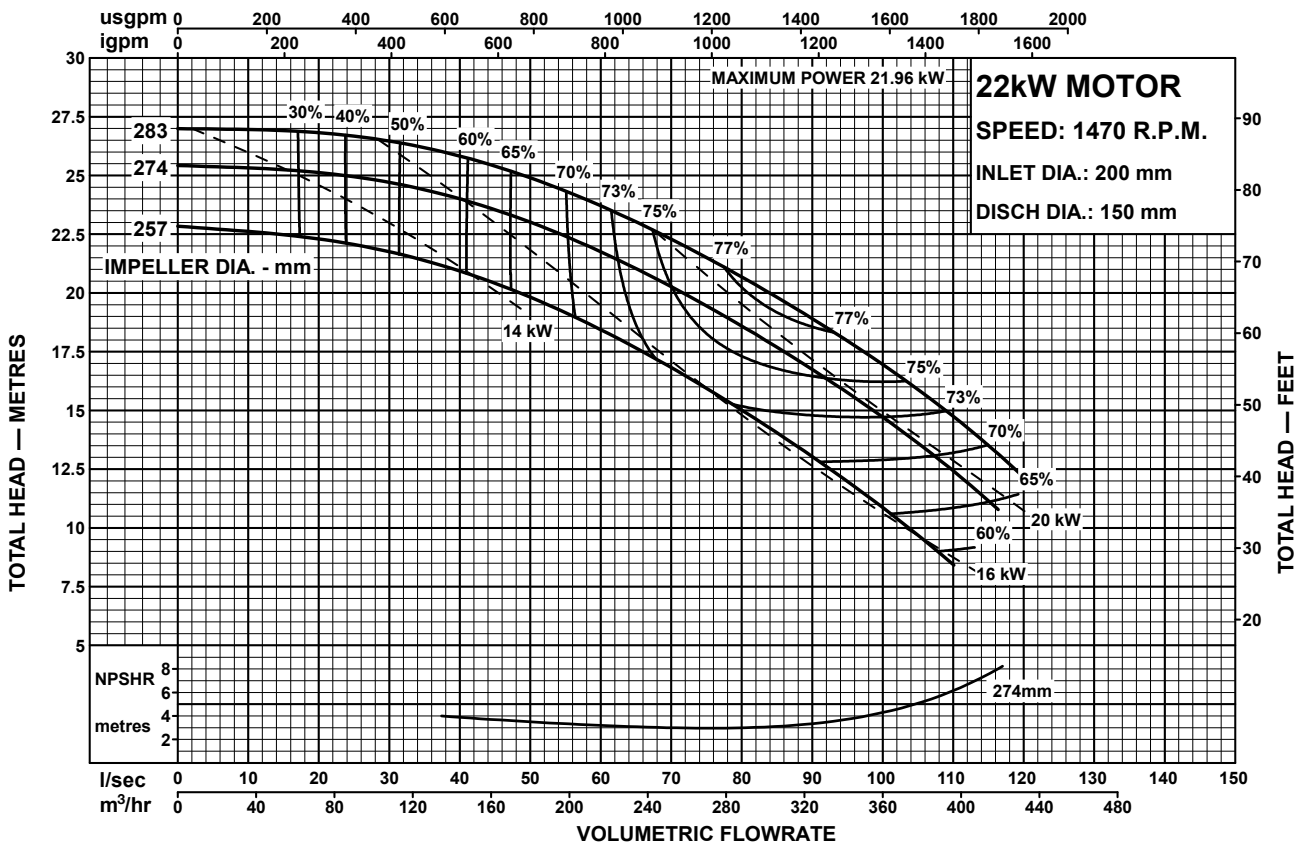

Performance to AS2417 Grade 2 for clean, cold water only.





# PENTAIR STARLINE

MOTORPUMPS

50Hz PERFORMANCE

## MODEL 200x150-400

CENTRIFUGAL PUMP PERFORMANCE DATA

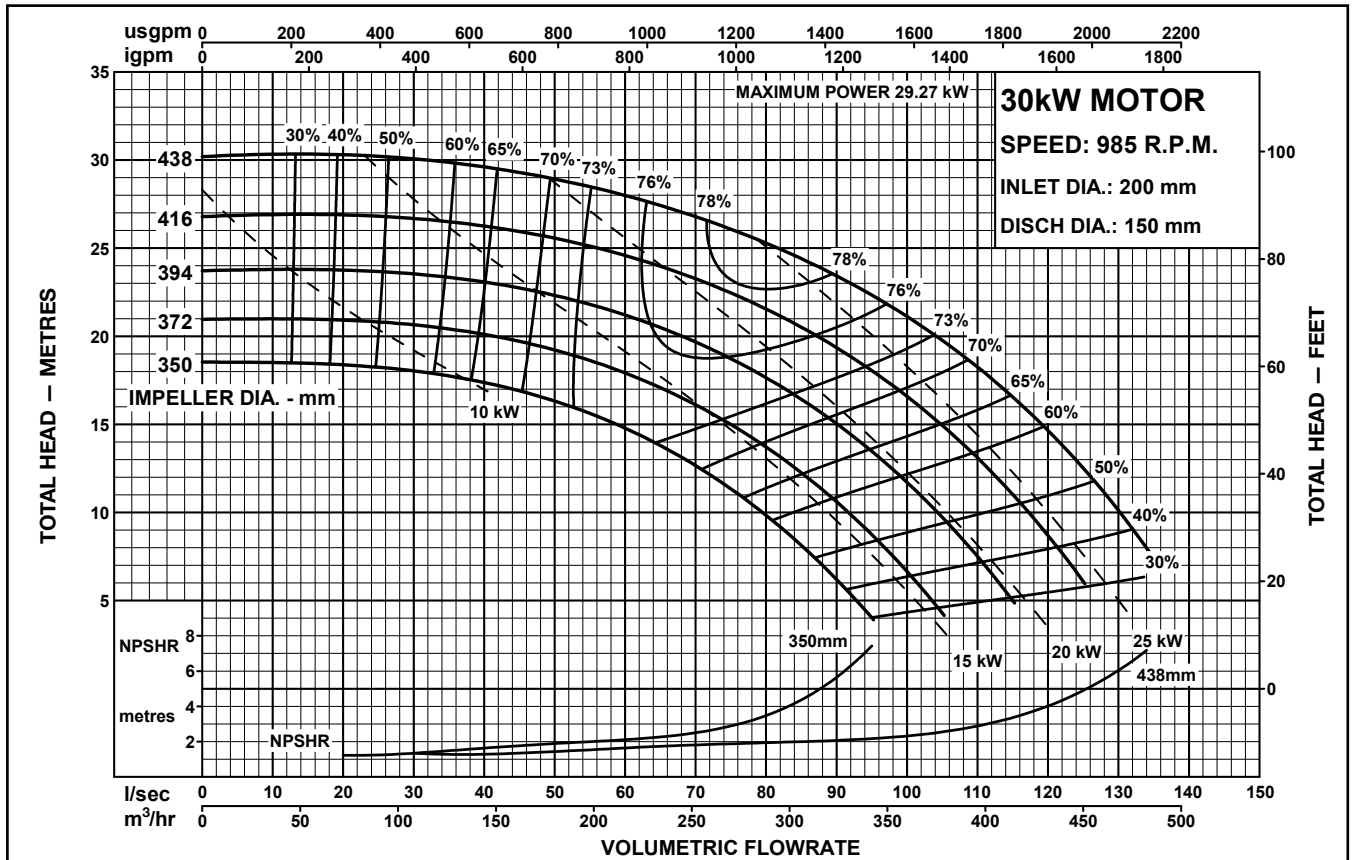

Performance to AS2417 Grade 2 for clean, cold water only.

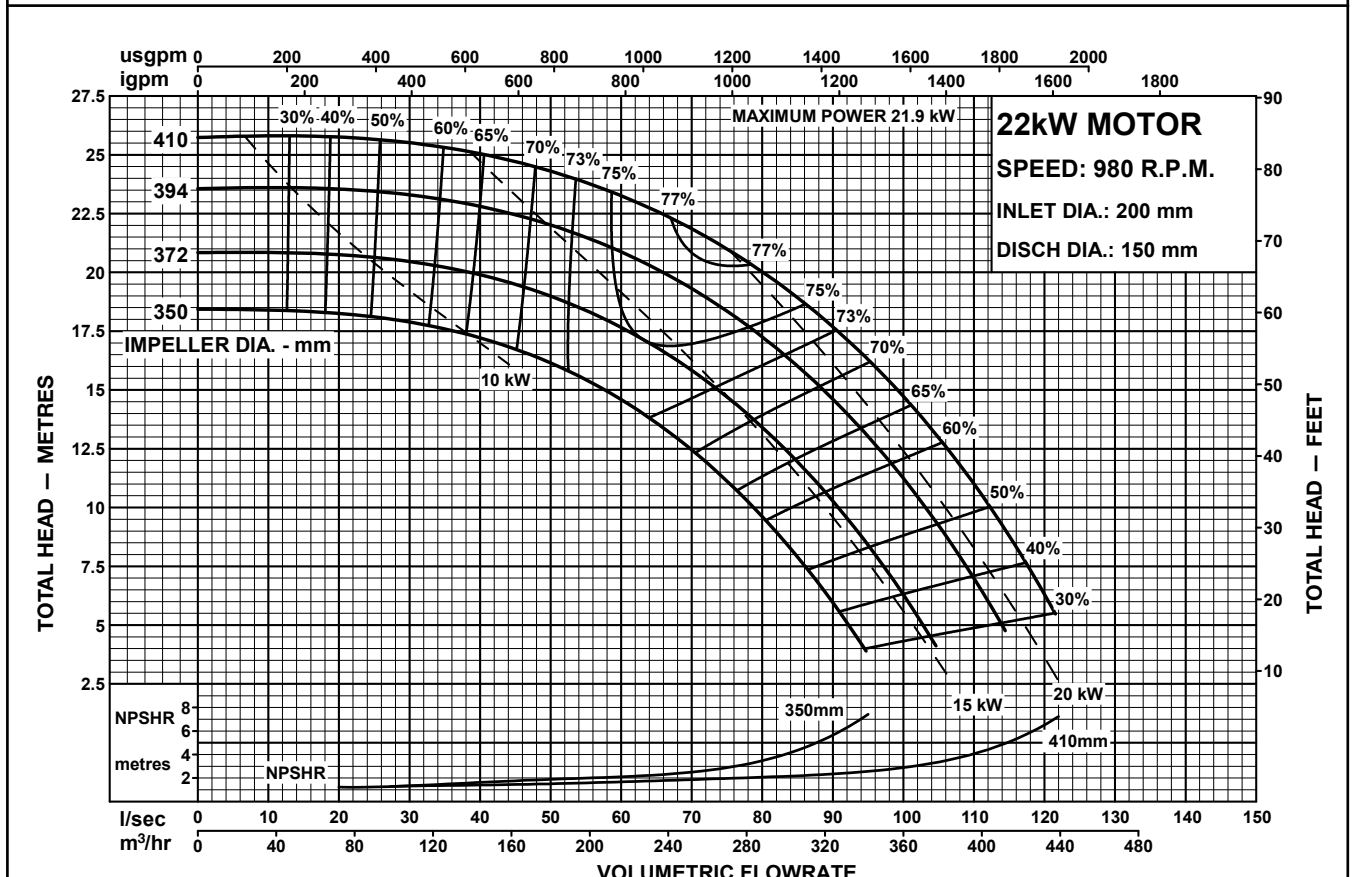

Performance to AS2417 Grade 2 for clean, cold water only.





# PENTAIR STARLINE

MOTORPUMPS  
50Hz PERFORMANCE

MODEL  
**200x150-400**

CENTRIFUGAL PUMP PERFORMANCE DATA

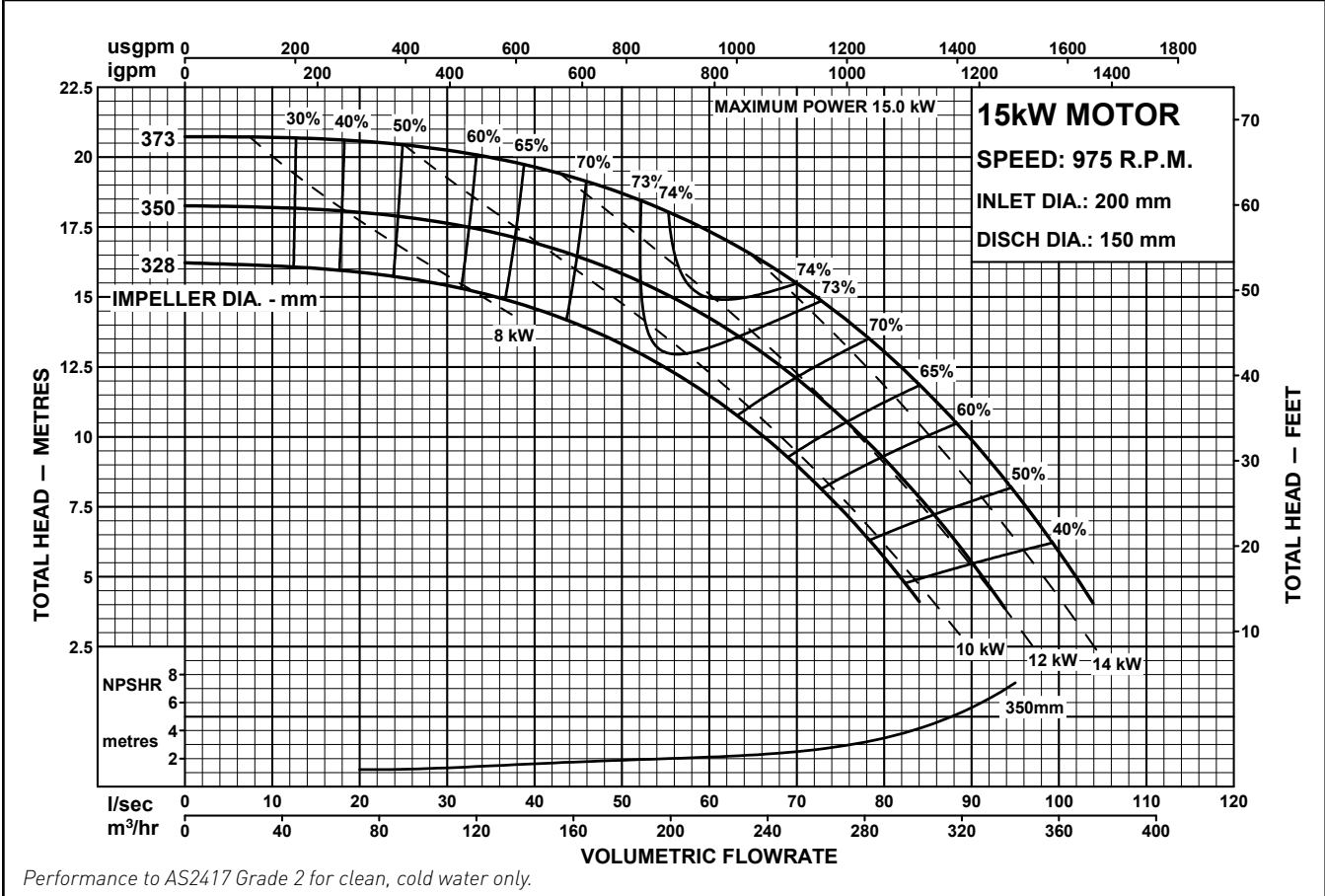
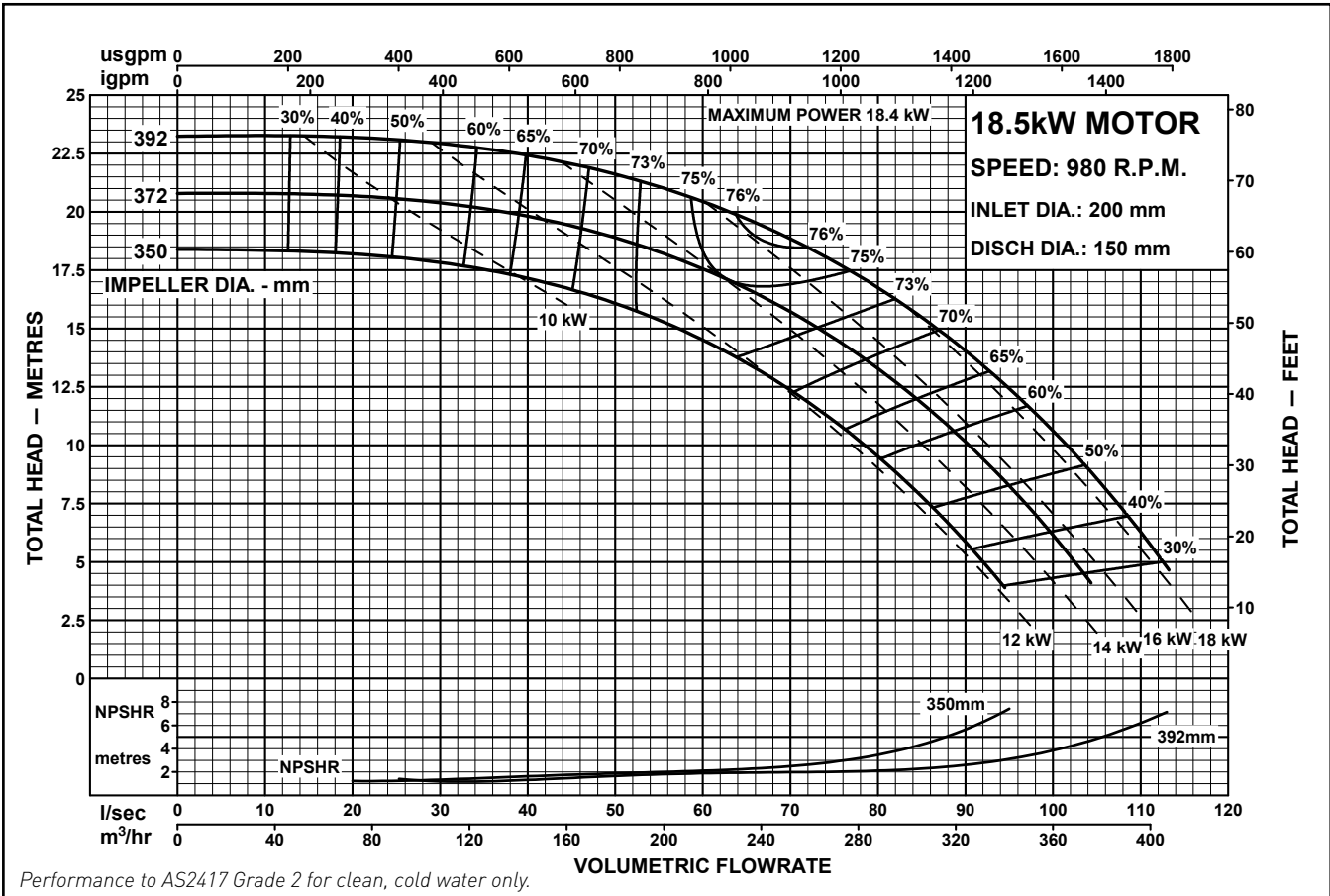



# PENTAIR STARLINE

MOTORPUMPS

50Hz PERFORMANCE

## MODEL 200x150-400

CENTRIFUGAL PUMP PERFORMANCE DATA

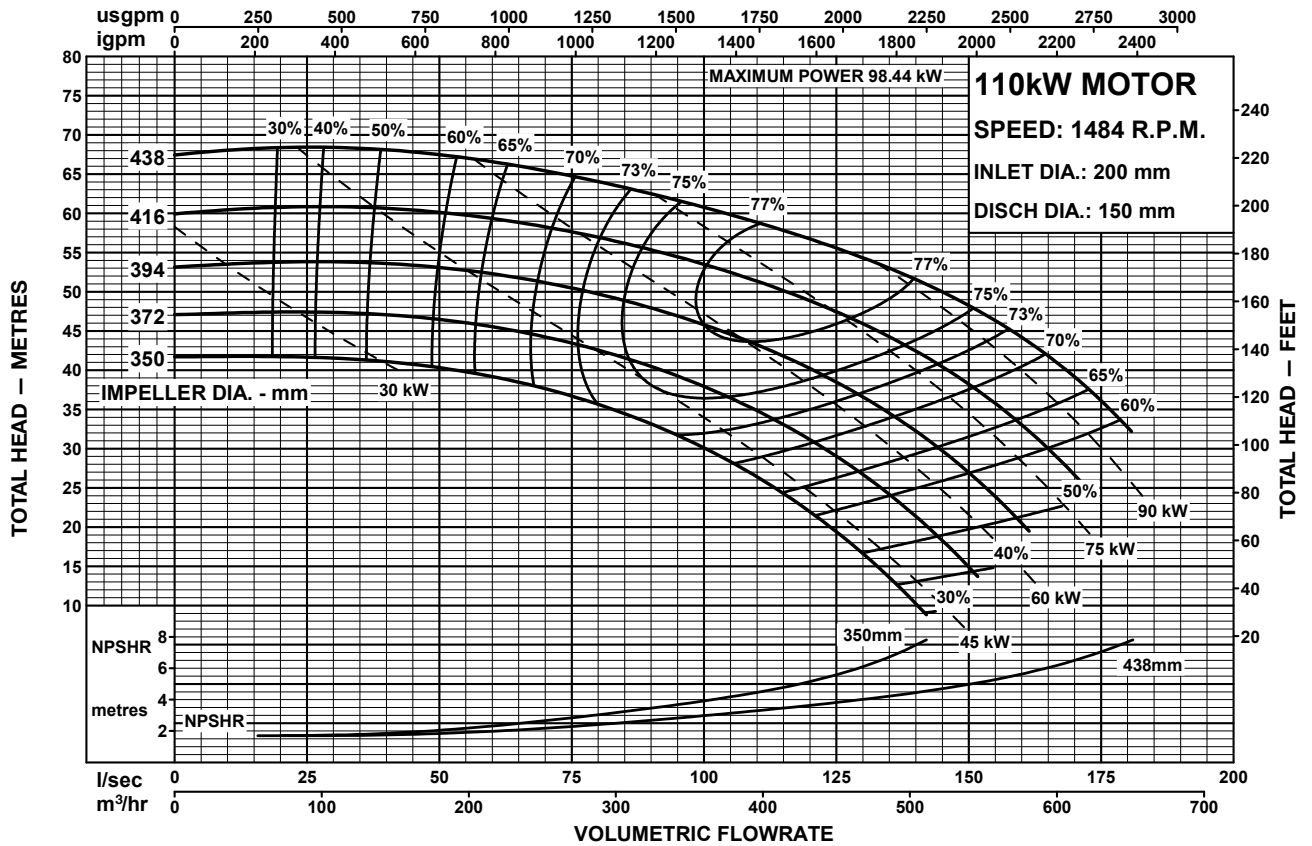

Performance to AS2417 Grade 2 for clean, cold water only.

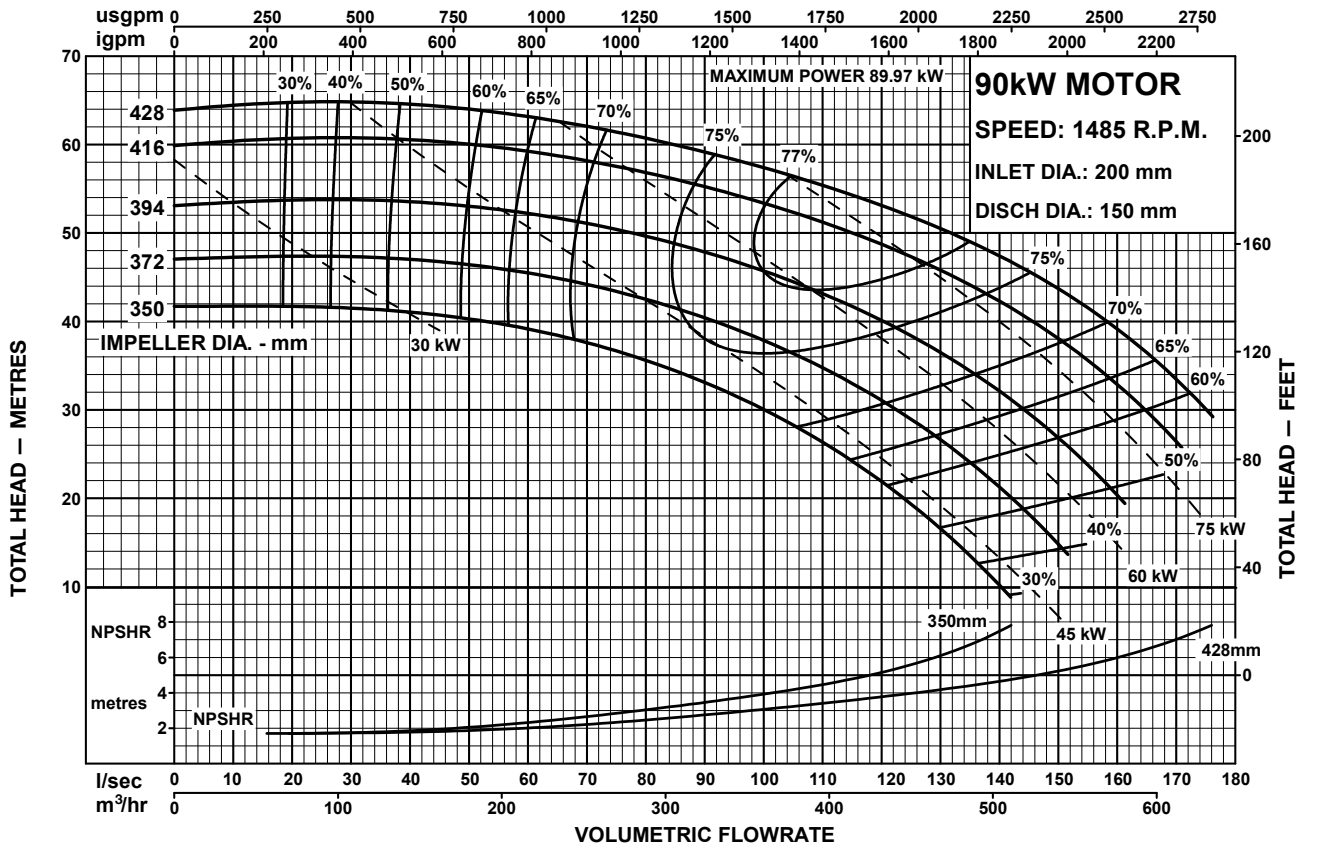

Performance to AS2417 Grade 2 for clean, cold water only.





# PENTAIR STARLINE

MOTORPUMPS  
50Hz PERFORMANCE

MODEL  
**200x150-400**

CENTRIFUGAL PUMP PERFORMANCE DATA

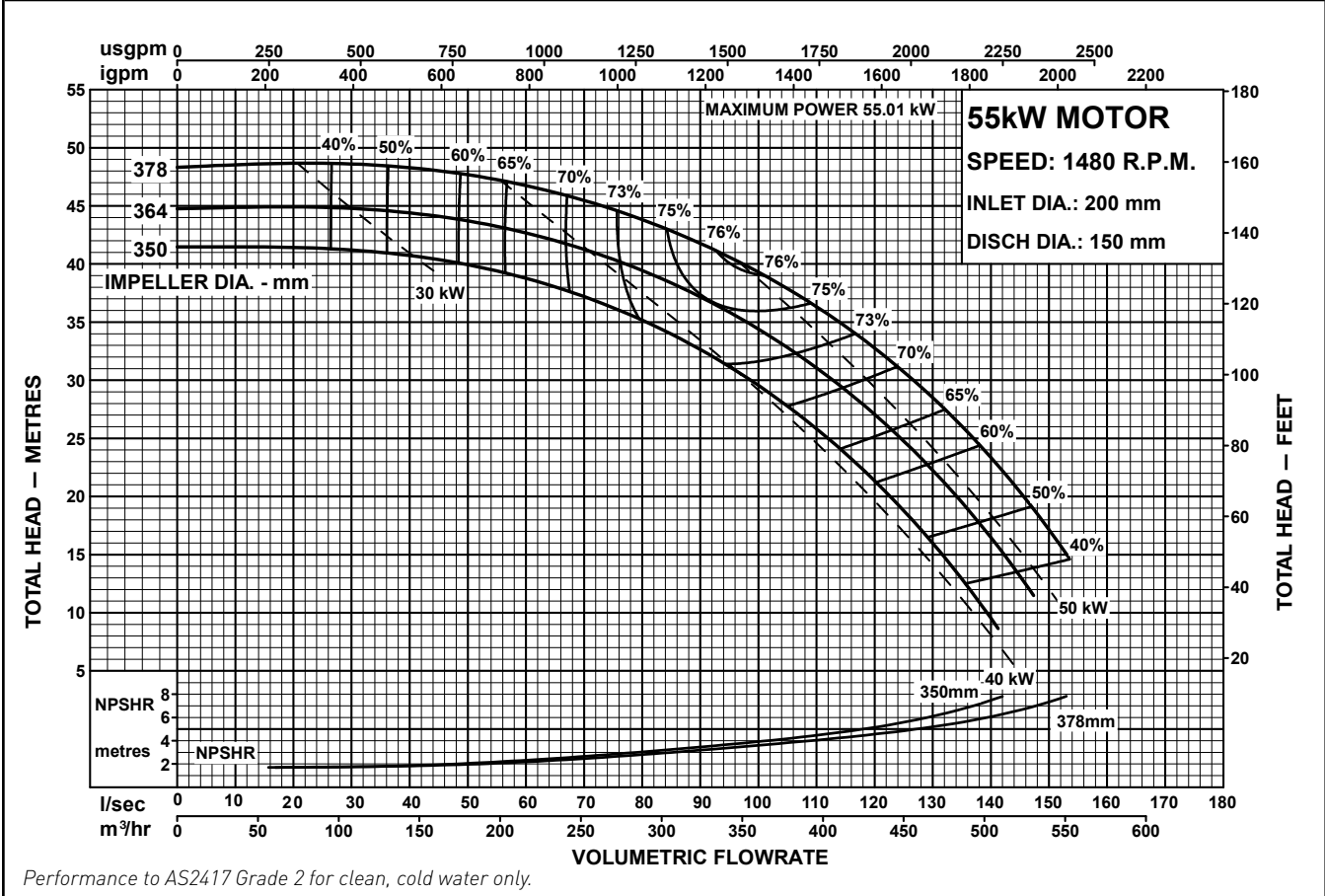
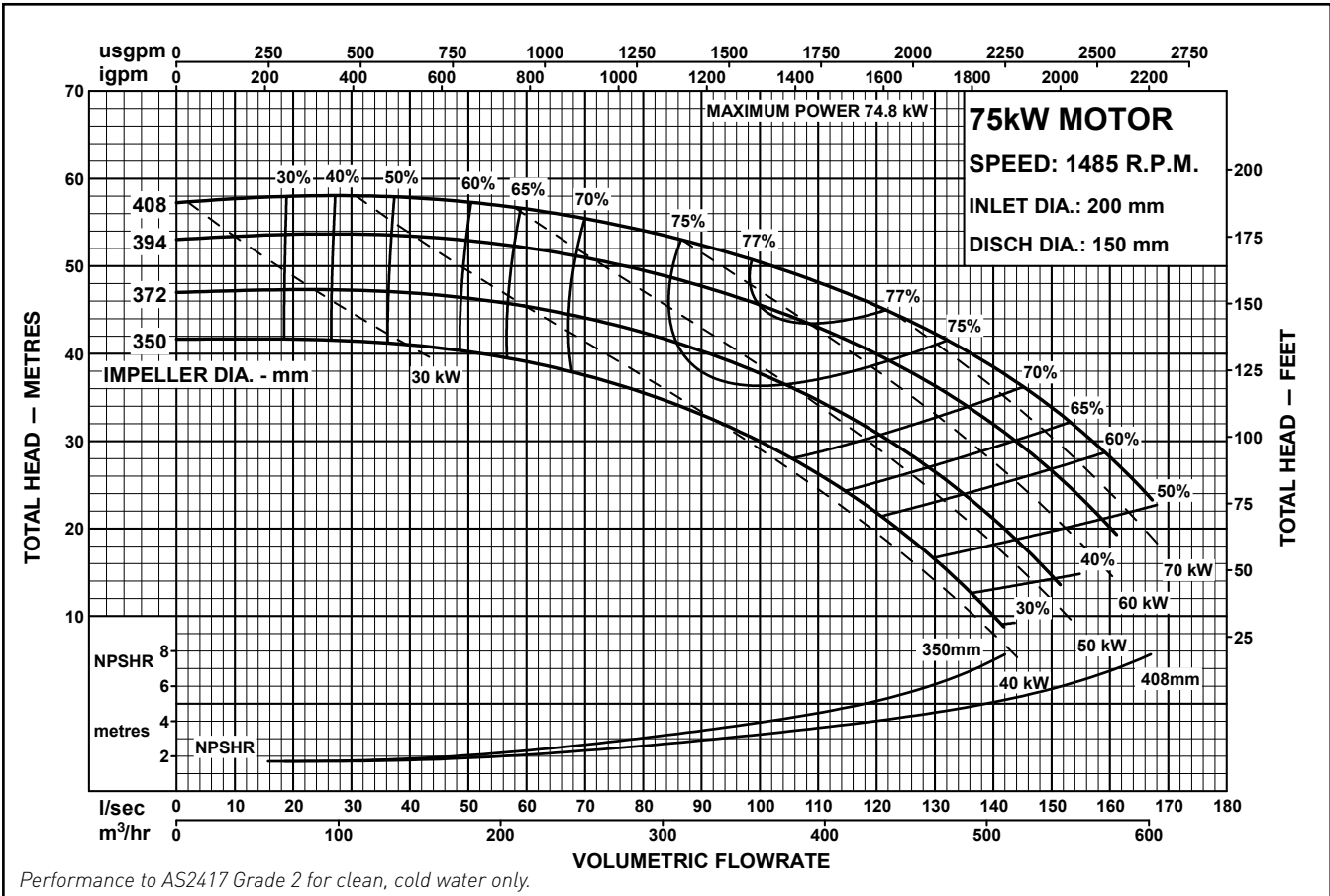





# PENTAIR STARLINE

MOTORPUMPS  
50Hz PERFORMANCE

MODEL  
**200x150-400**

CENTRIFUGAL PUMP PERFORMANCE DATA

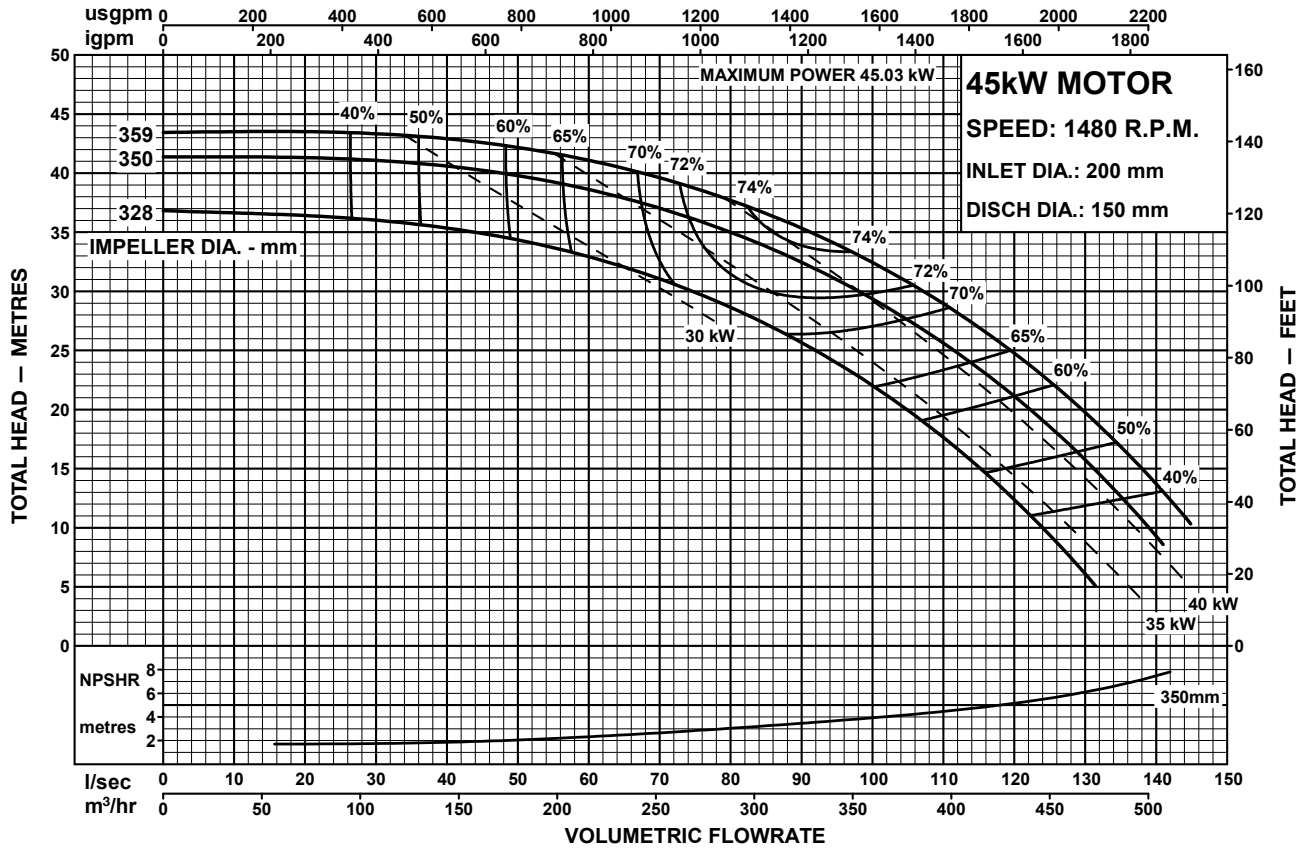

Performance to AS2417 Grade 2 for clean, cold water only.





# PENTAIR STARLINE

MOTORPUMPS  
50Hz PERFORMANCE

MODEL  
**200x150-500**

CENTRIFUGAL PUMP PERFORMANCE DATA

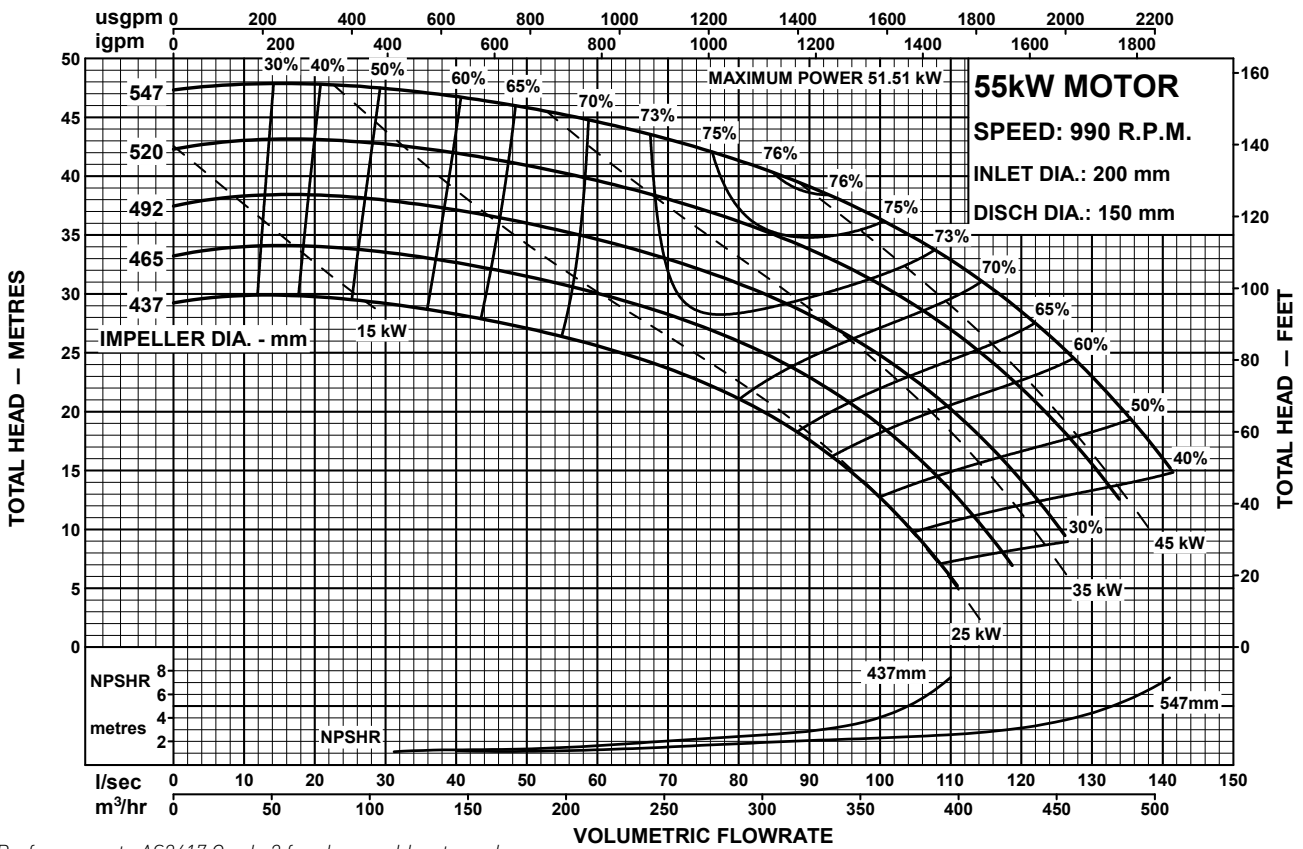

Performance to AS2417 Grade 2 for clean, cold water only.

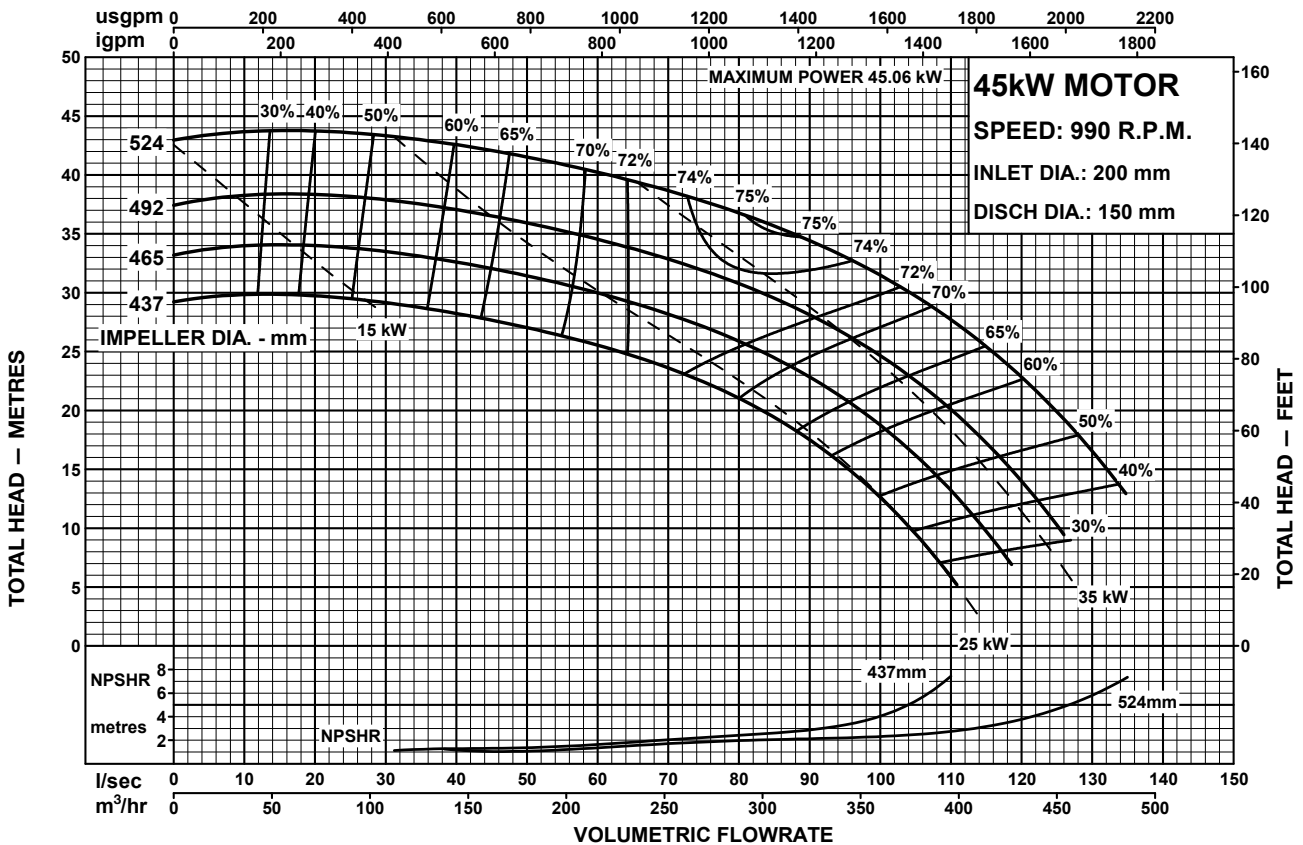

Performance to AS2417 Grade 2 for clean, cold water only.





# PENTAIR STARLINE

MOTORPUMPS

50Hz PERFORMANCE

## MODEL 200x150-500

CENTRIFUGAL PUMP PERFORMANCE DATA

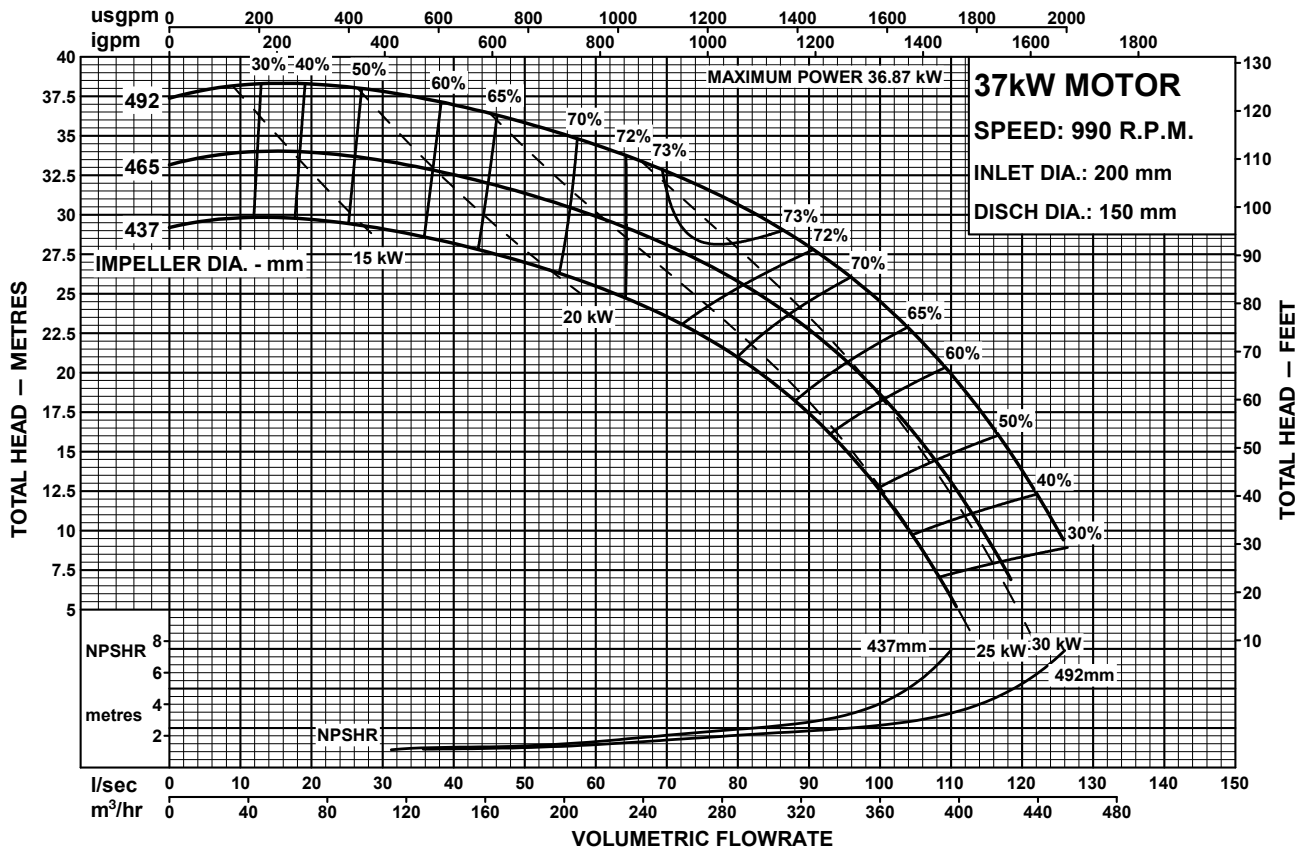

Performance to AS2417 Grade 2 for clean, cold water only.

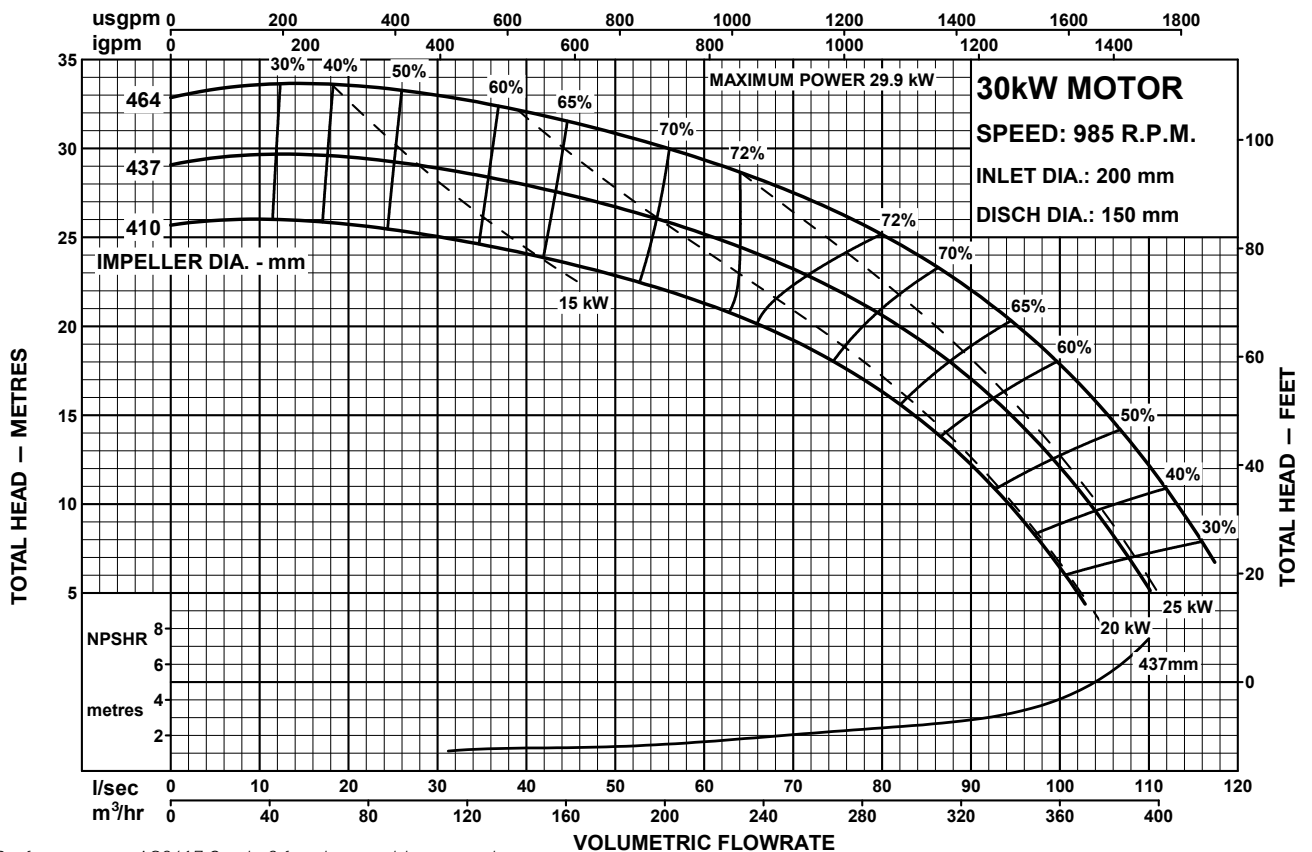

Performance to AS2417 Grade 2 for clean, cold water only.





# PENTAIR STARLINE

MOTORPUMPS  
50Hz PERFORMANCE

MODEL  
**200x150-500**

CENTRIFUGAL PUMP PERFORMANCE DATA

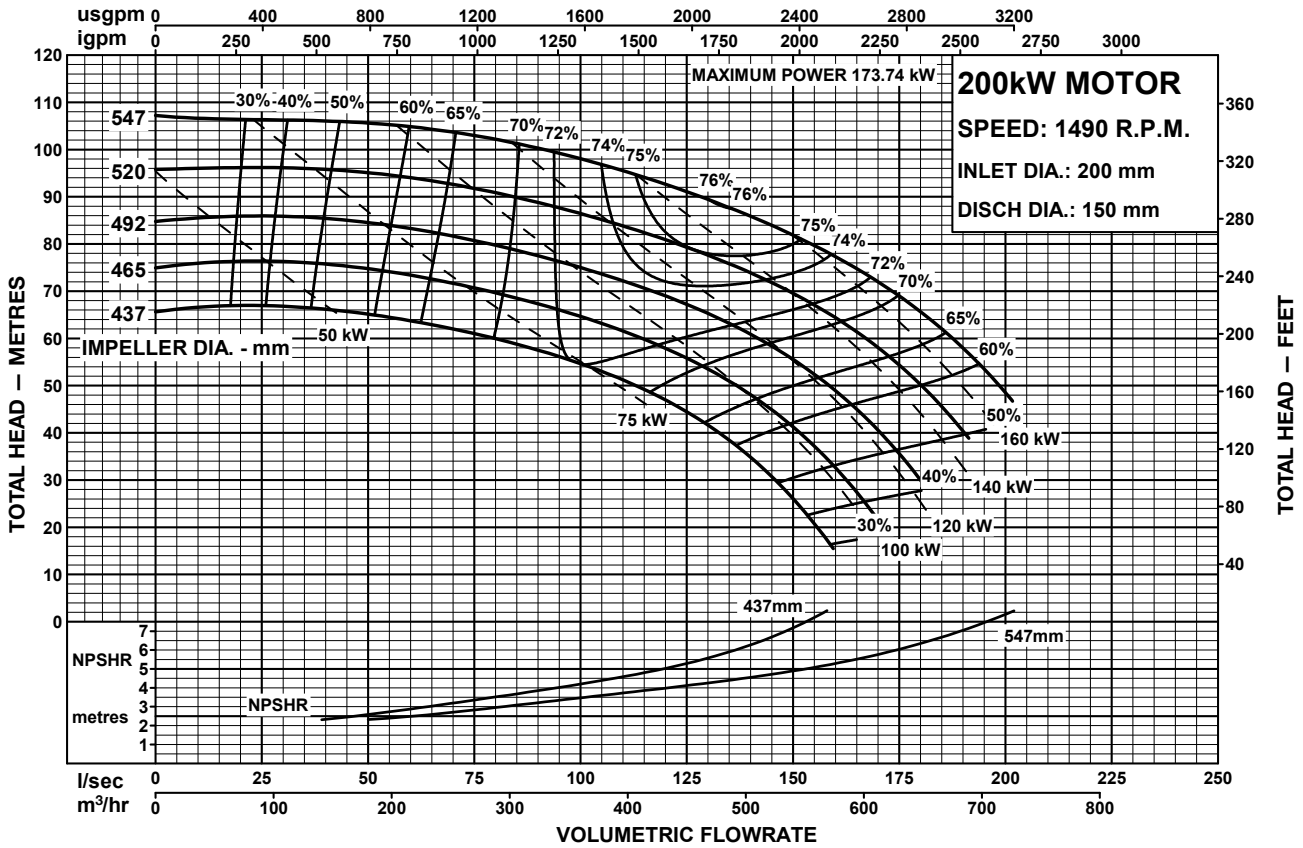

Performance to AS2417 Grade 2 for clean, cold water only.

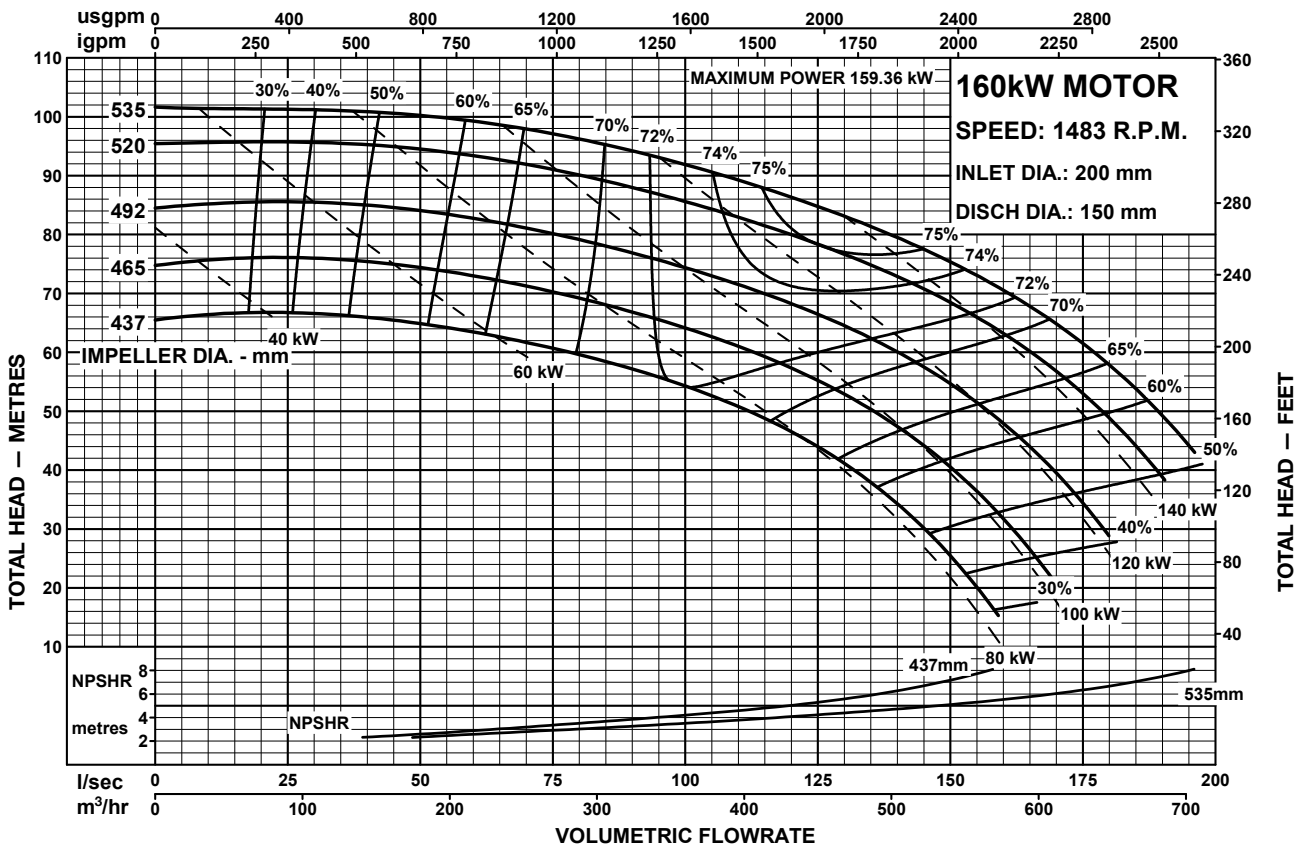

Performance to AS2417 Grade 2 for clean, cold water only.





# PENTAIR STARLINE

MOTORPUMPS

50Hz PERFORMANCE

## MODEL 200x150-500

CENTRIFUGAL PUMP PERFORMANCE DATA

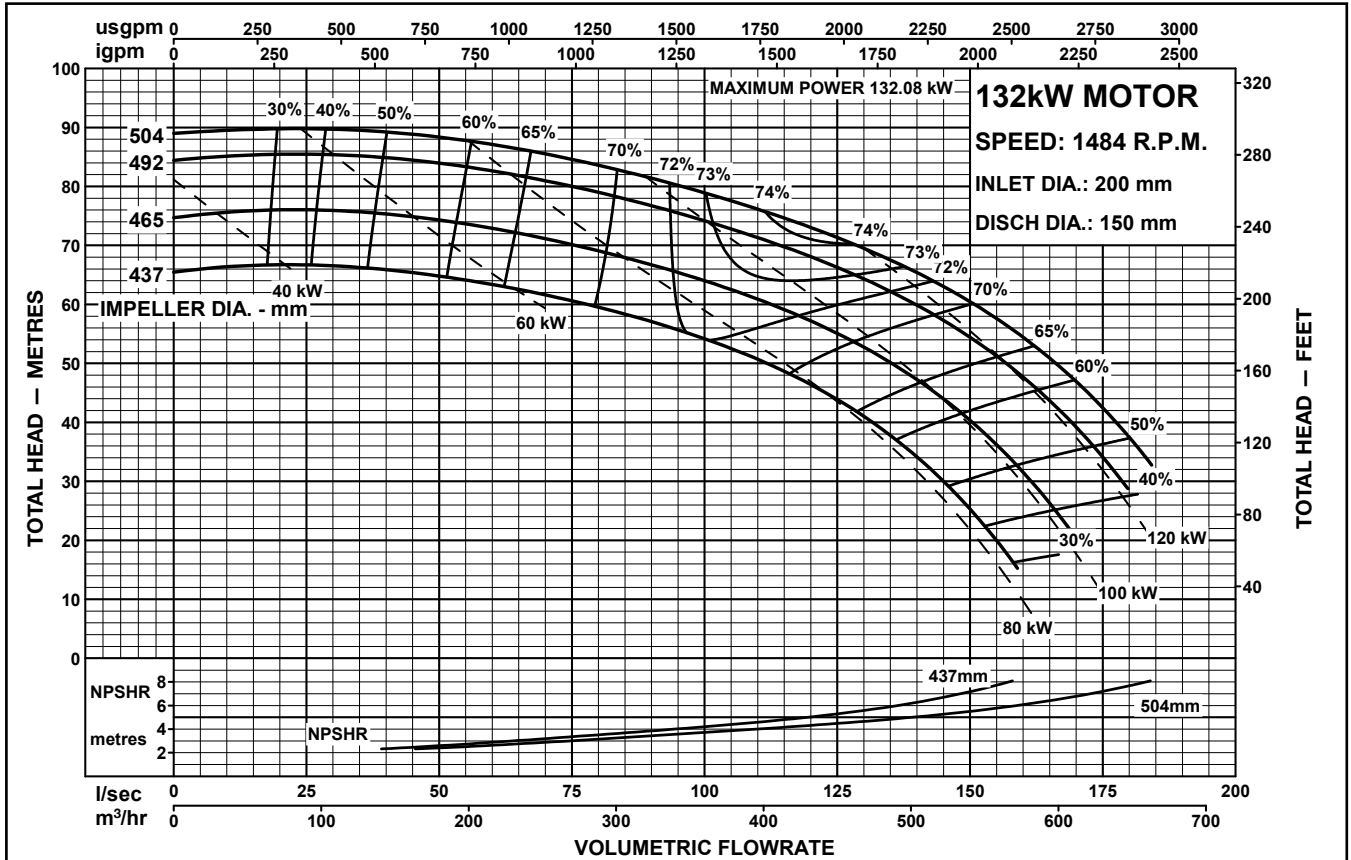

Performance to AS2417 Grade 2 for clean, cold water only.

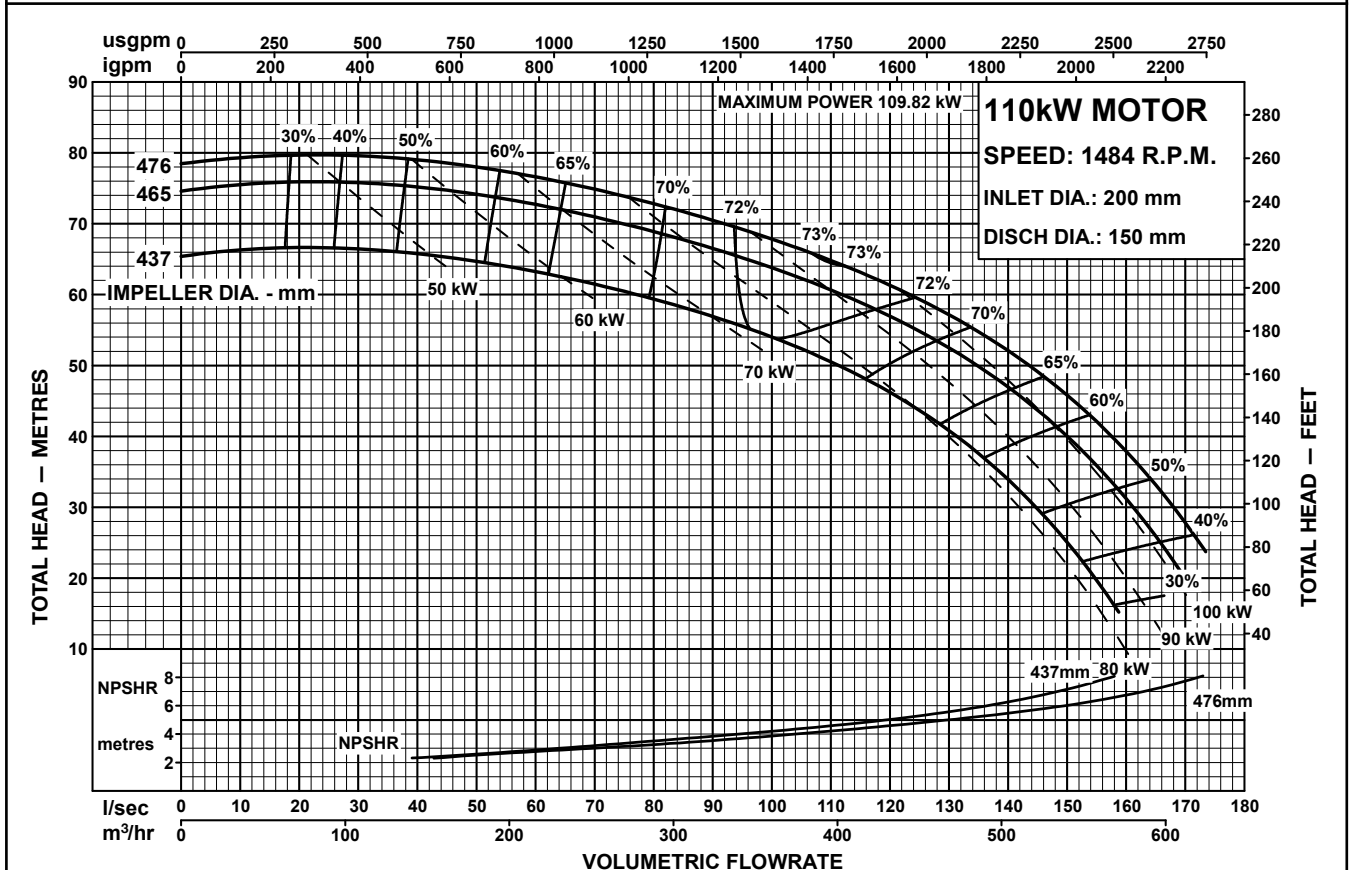

Performance to AS2417 Grade 2 for clean, cold water only.





# PENTAIR STARLINE

MOTORPUMPS  
50Hz PERFORMANCE

MODEL  
**200x150-500**

CENTRIFUGAL PUMP PERFORMANCE DATA

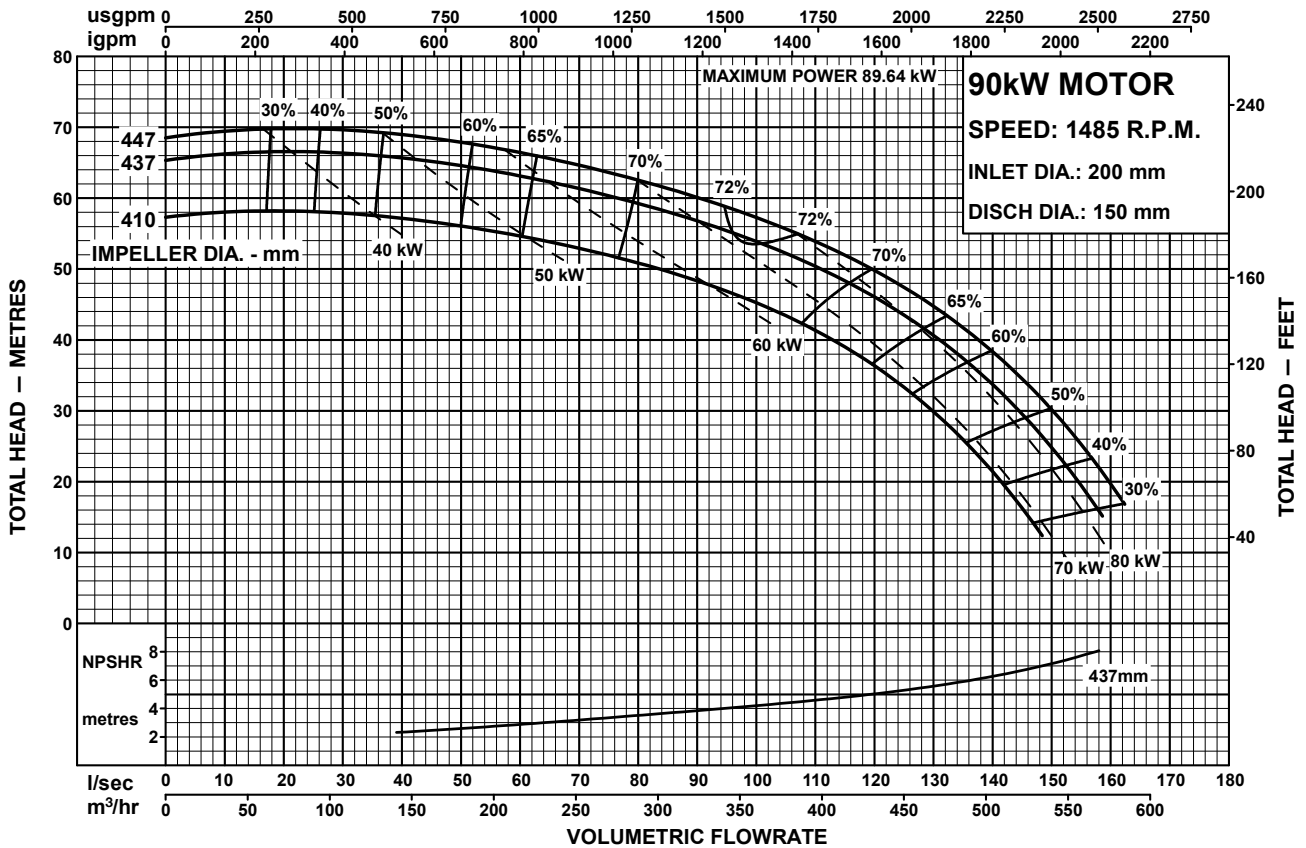

Performance to AS2417 Grade 2 for clean, cold water only.





# PENTAIR STARLINE

MOTORPUMPS

50Hz PERFORMANCE

## MODEL 250x200-315

CENTRIFUGAL PUMP PERFORMANCE DATA

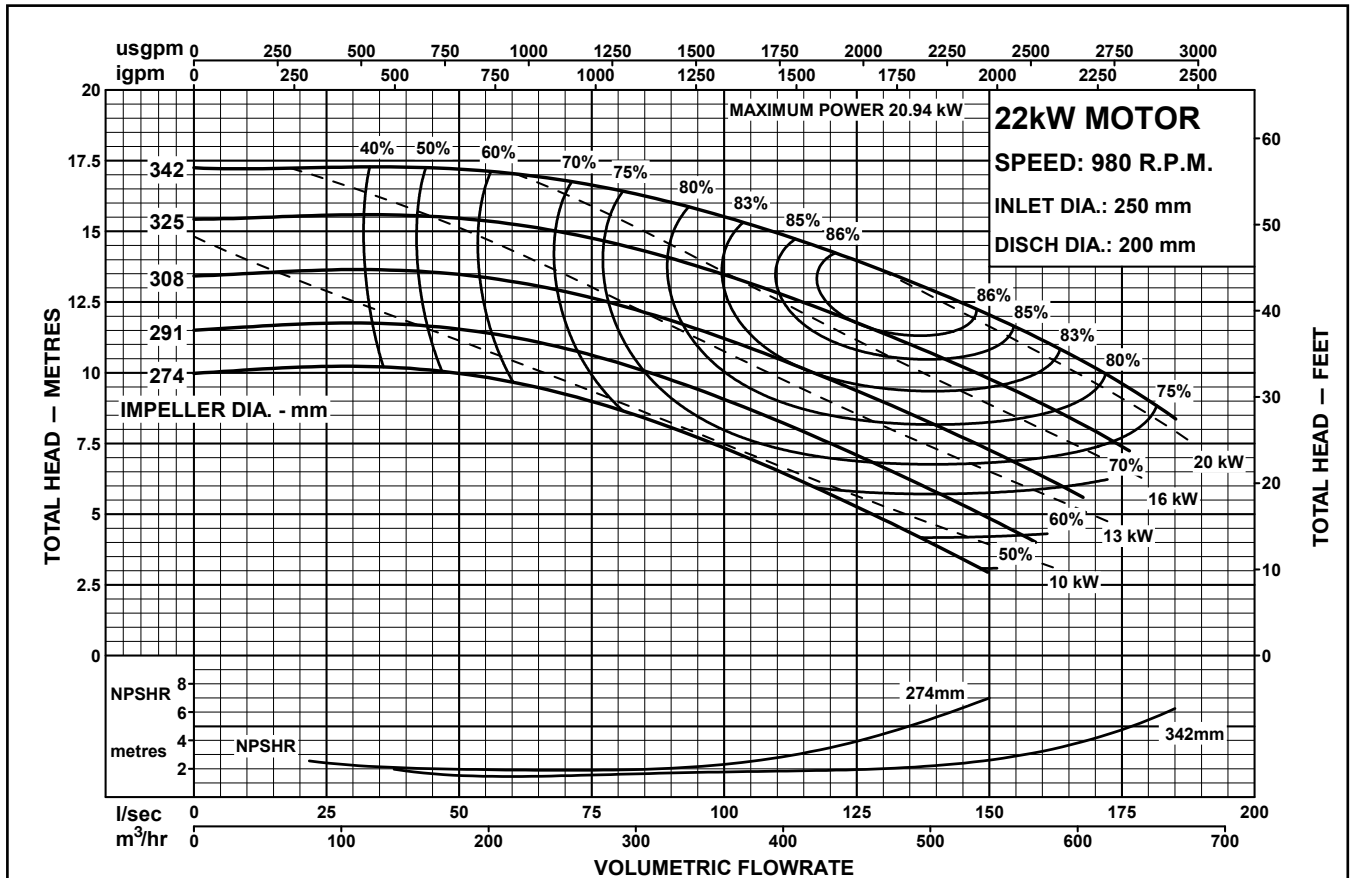

Performance to AS2417 Grade 2 for clean, cold water only.

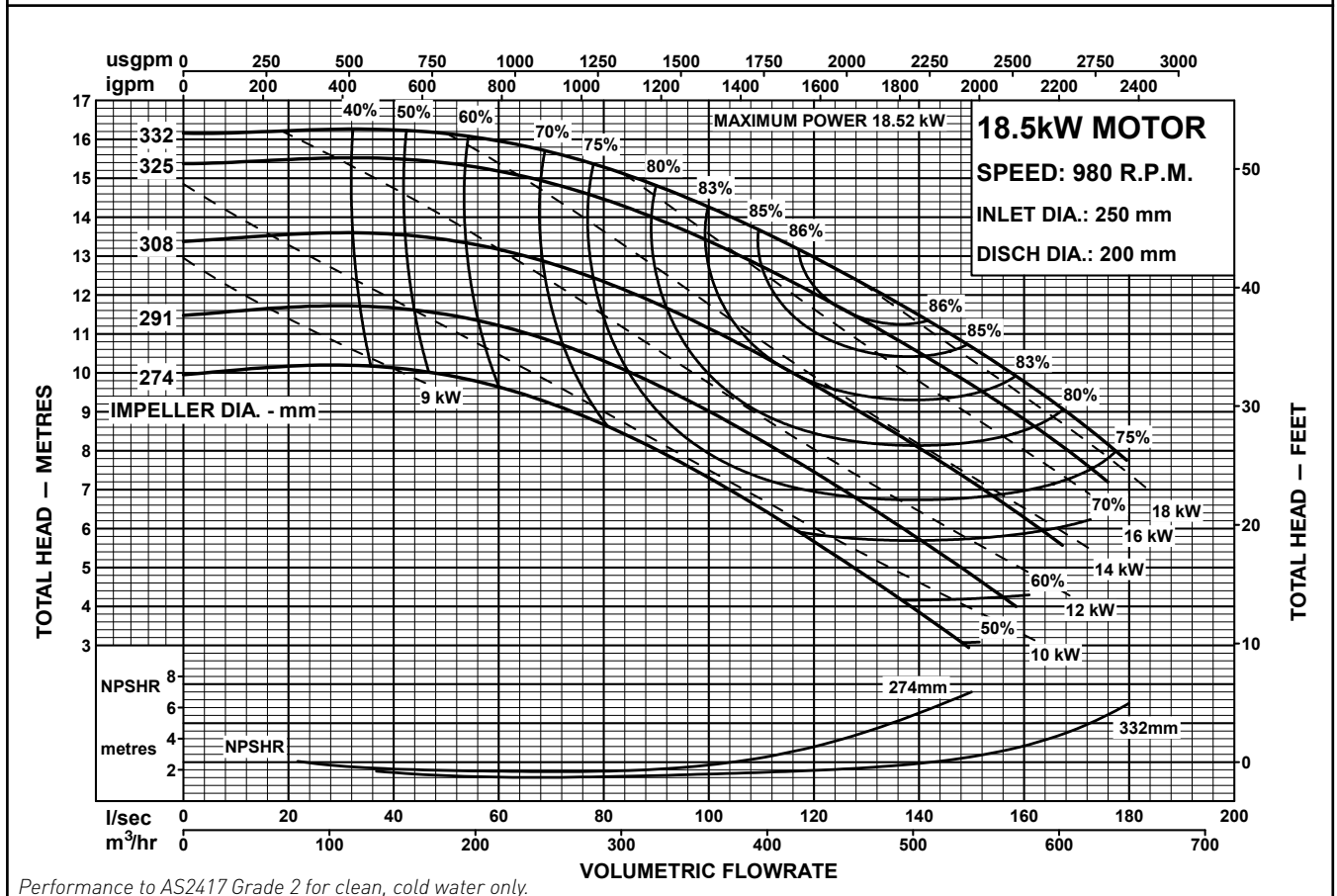

Performance to AS2417 Grade 2 for clean, cold water only.





# PENTAIR STARLINE

MOTORPUMPS  
50Hz PERFORMANCE

MODEL  
**250x200-315**

CENTRIFUGAL PUMP PERFORMANCE DATA

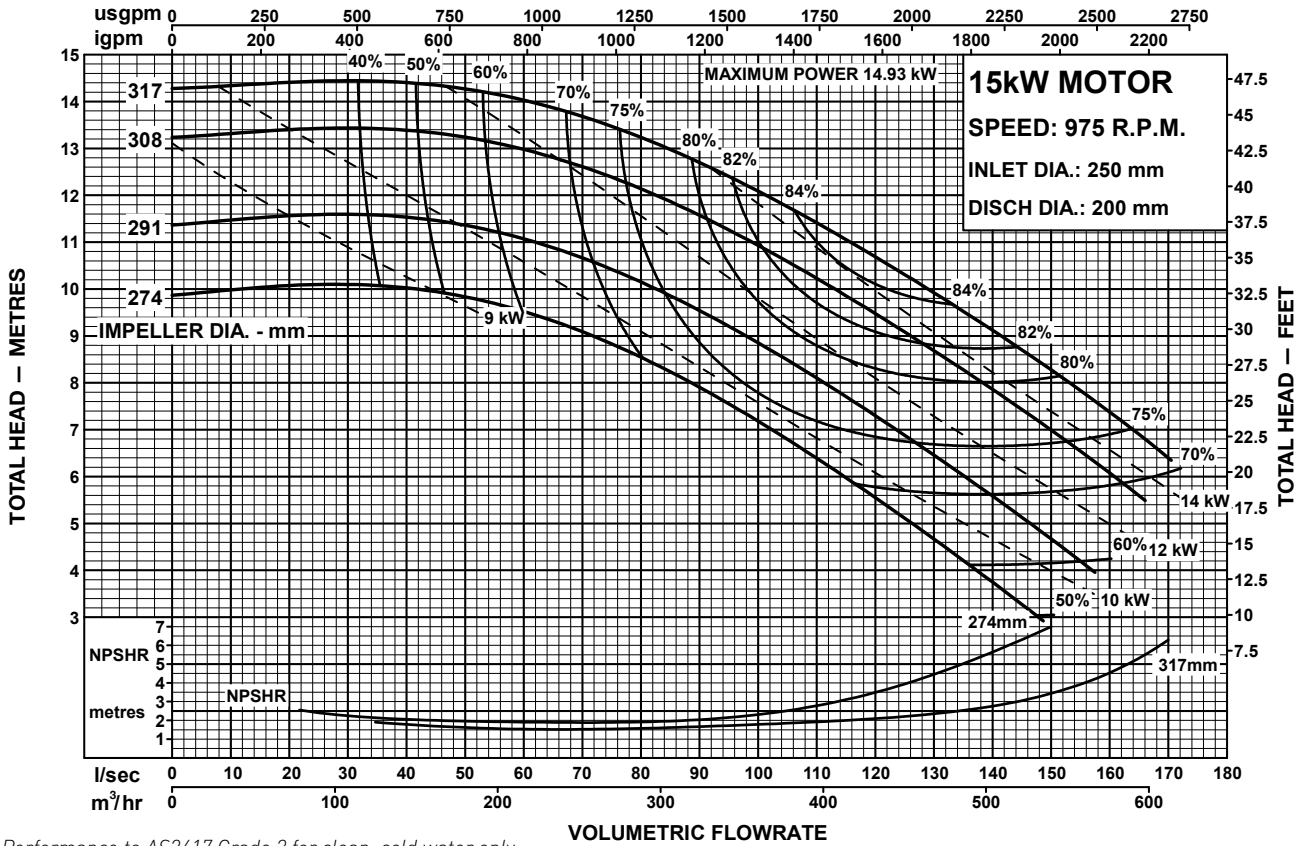

Performance to AS2417 Grade 2 for clean, cold water only.

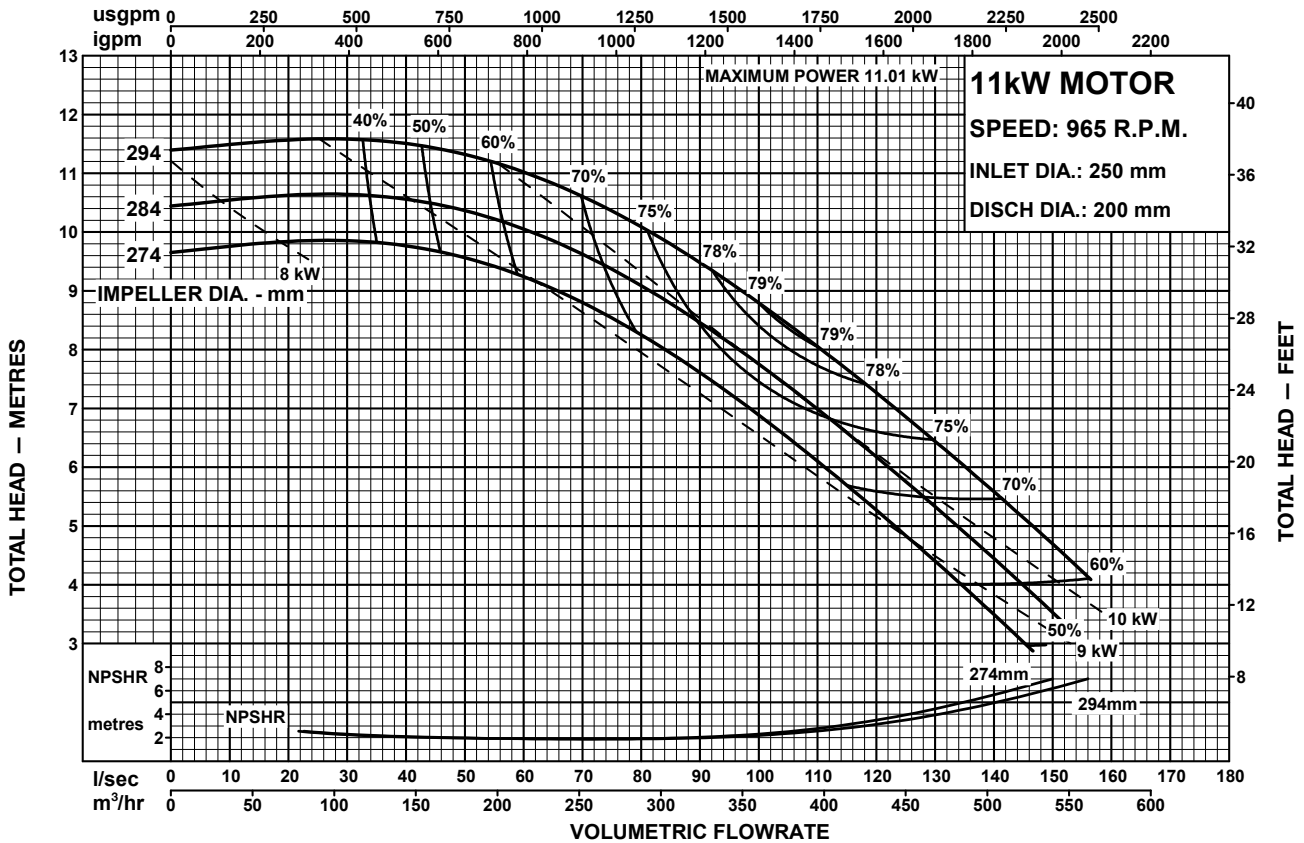

Performance to AS2417 Grade 2 for clean, cold water only.







# PENTAIR STARLINE

MOTORPUMPS

50Hz PERFORMANCE

## MODEL 250x200-315

CENTRIFUGAL PUMP PERFORMANCE DATA

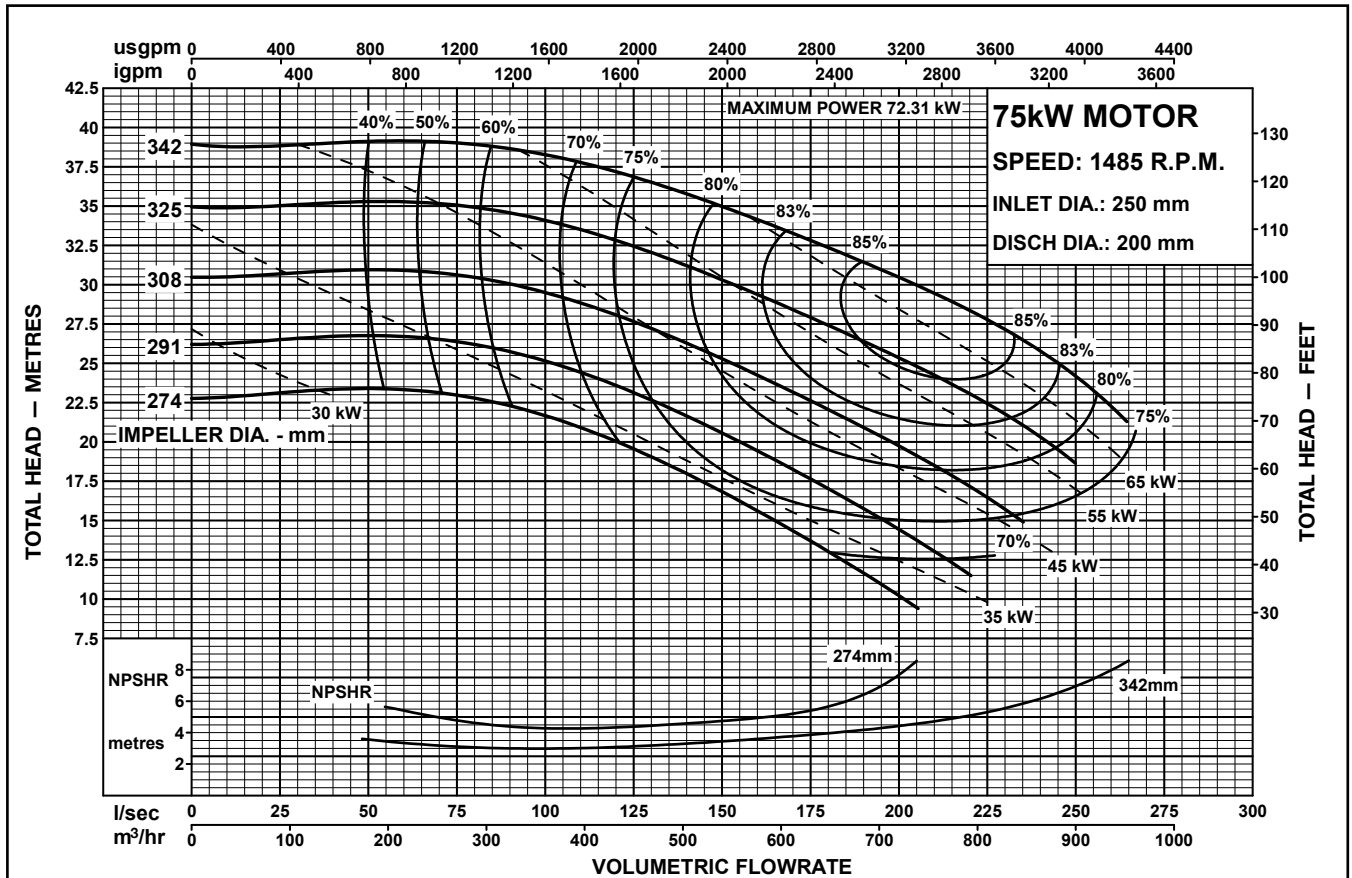

Performance to AS2417 Grade 2 for clean, cold water only.

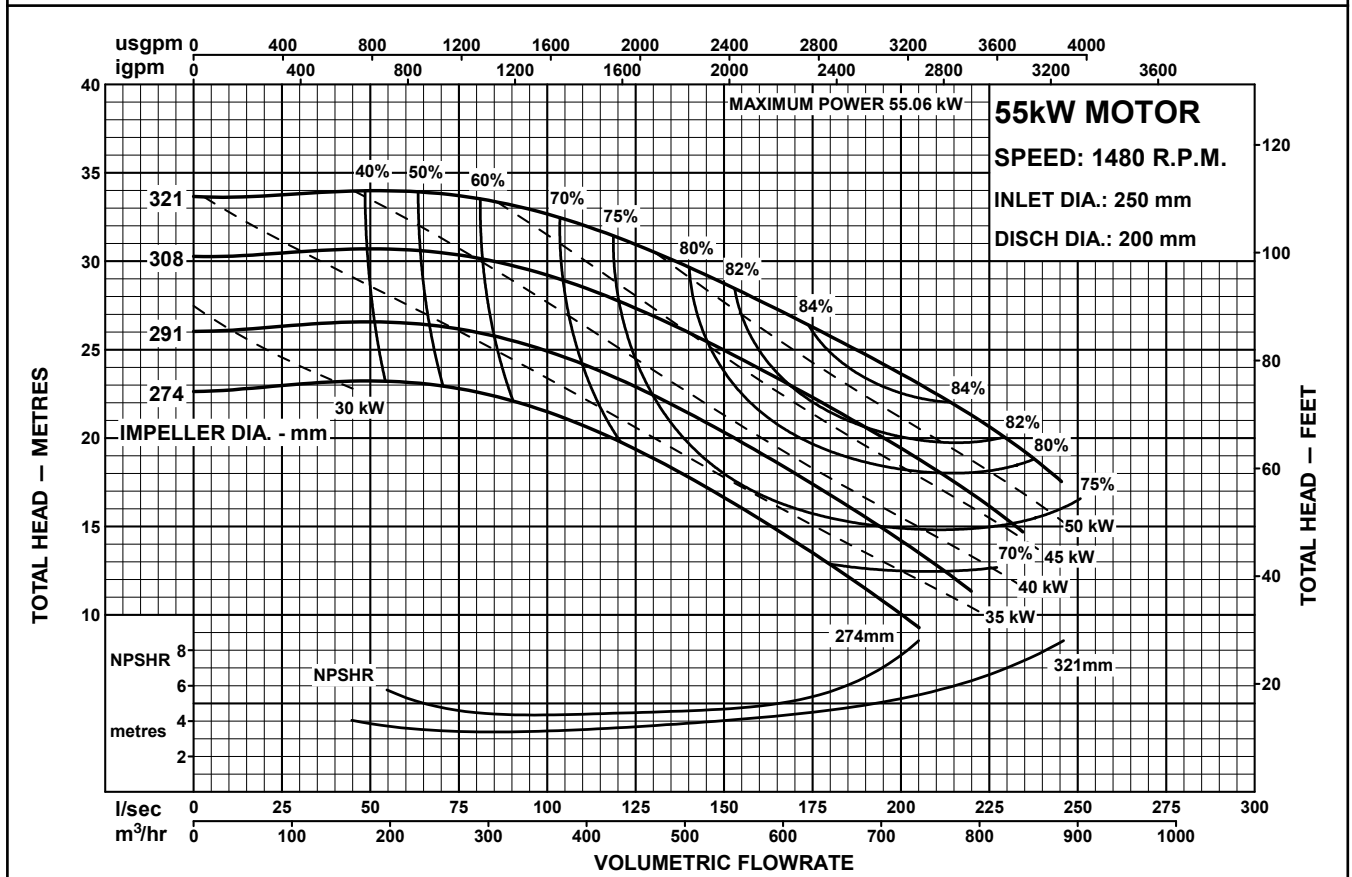

Performance to AS2417 Grade 2 for clean, cold water only.





# PENTAIR STARLINE

MOTORPUMPS  
50Hz PERFORMANCE

MODEL  
**250x200-315**

CENTRIFUGAL PUMP PERFORMANCE DATA

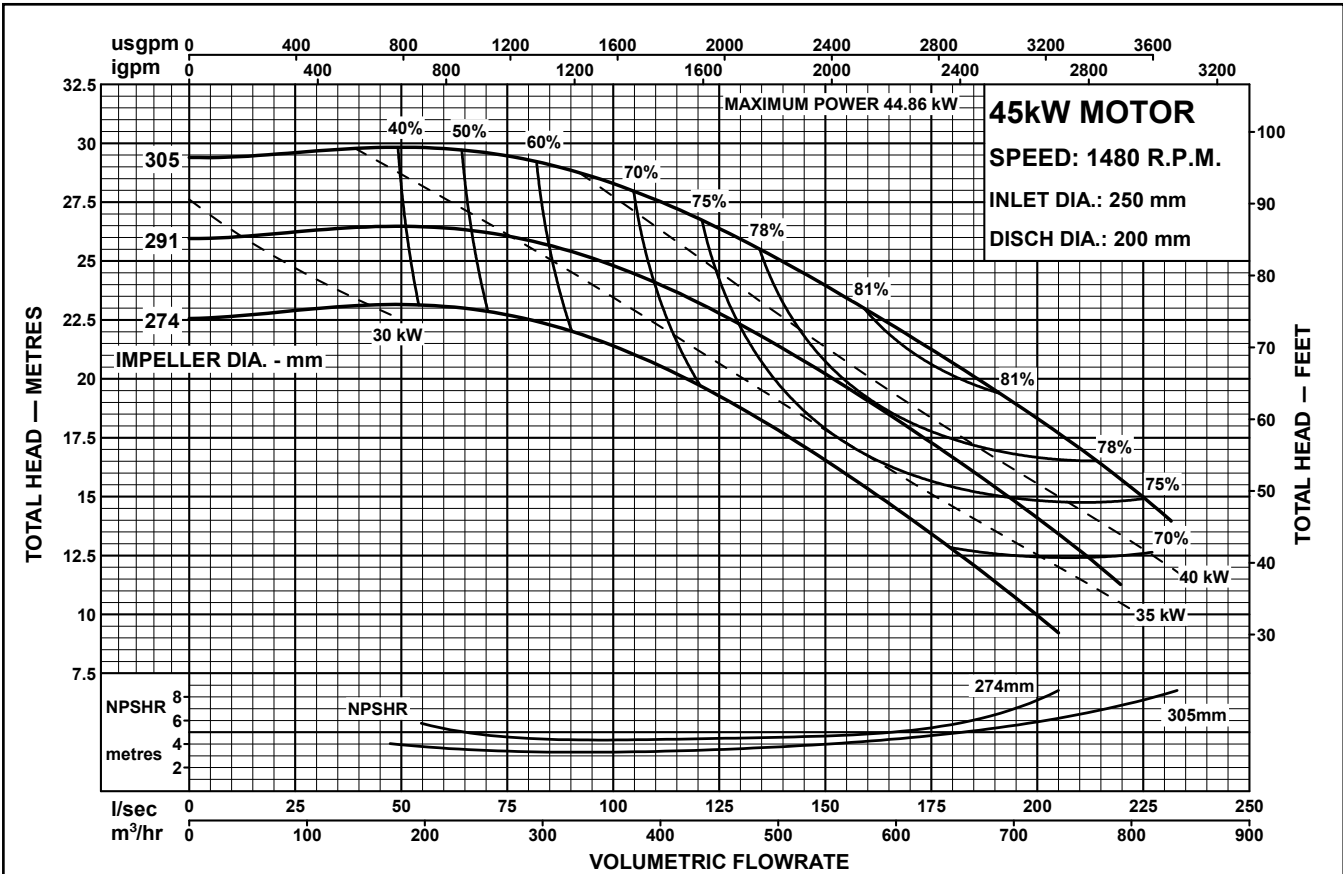

Performance to AS2417 Grade 2 for clean, cold water only.

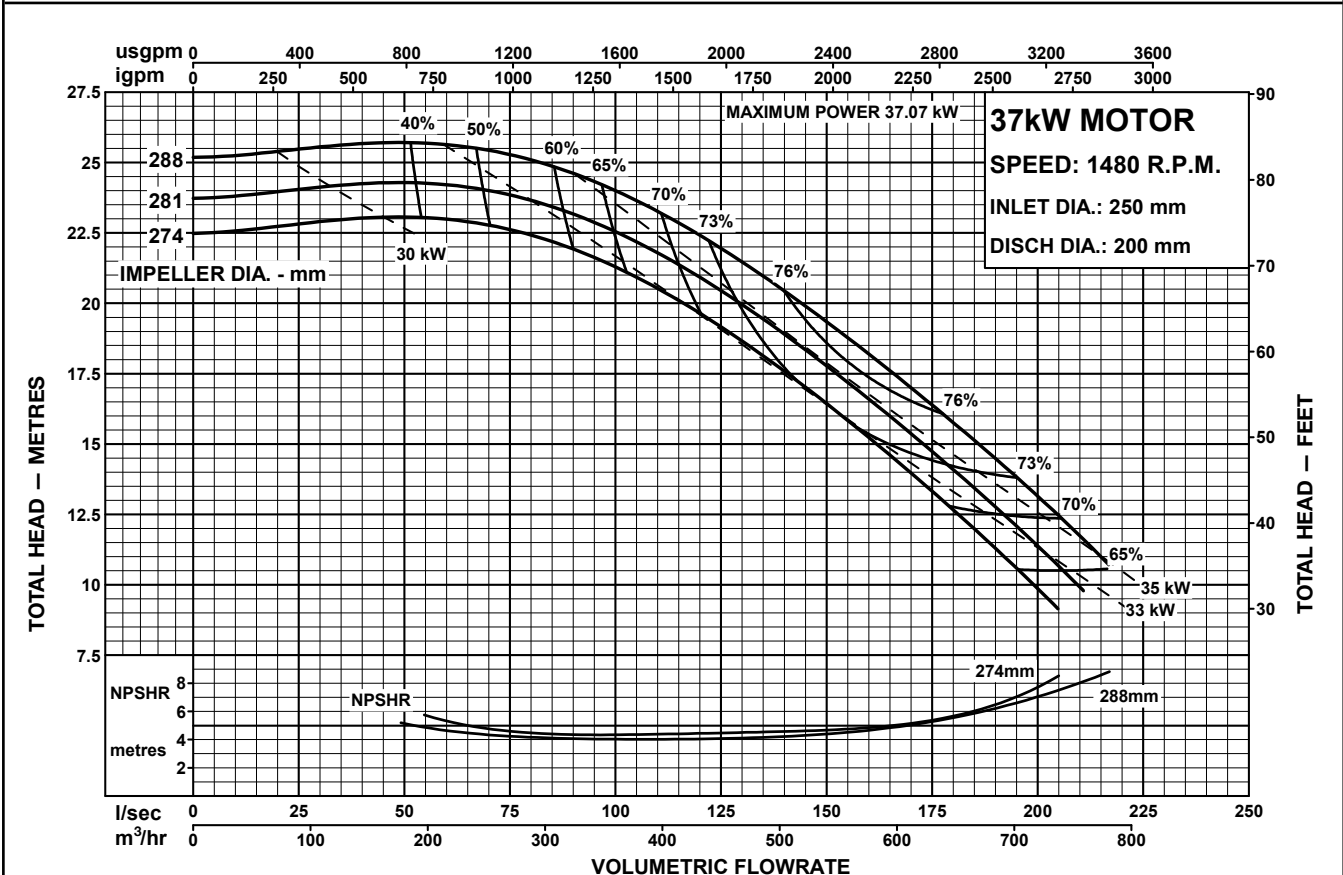

Performance to AS2417 Grade 2 for clean, cold water only.

