

43SOUTH

PENTAIR

AQUATIC SYSTEMS 2024 PRICE LIST



YOUR ONE-STOP POOL SHOP

Pumps, filtration, heating, cleaning, automation, sanitation, lighting or white goods, we have the right products for your swimming pool!

0800 654 112 | 43south.co.nz

VOLUME 1





43SOUTH DELIVERING QUALITY BRANDS BACKED BY A KNOWLEDGEABLE & PASSIONATE TEAM

OUR STORY

43South is a New Zealand Family owned and operated business focused on delivering a brilliant customer experience. Our story started in 2017, bringing a fresh approach to the industry. We specialise in pumps, motors, filtration, and aquatic products and pride ourselves on our family of brands.

We value building great relationships with our distributors and customers, without them our business would not be possible. The team at 43South has an active part in our local community, supporting charities and organisations close to home.

We're here to help, here when you need us, and here for the long haul!

You and your customers can rely on a high level of technical support and local industry knowledge. Bigger isn't always better - as a local company, we are remarkably agile. Our team will get onto it quickly and professionally, saving you time and headaches.

Our team is diverse and comes from a range of different backgrounds - we have a lot of different experiences and areas of expertise to bring to the table! One thing we all have in common: we're excited to be part of a keen company that's up for the challenge of taking on bigger multinational companies.



CONTENTS

PRODUCT SELECTION GUIDE 4

POOL PUMPS 5

IntelliFlo® 2 VSF	6
SilentFlo®	8
EnviroMAX® 800, 1500.....	10
Max-E-Pro®	12
WhisperFlo®.....	14
IntelliFlo® XF / WhisperFlo® XF	16
Pantera Evolution.....	18
Pantera	19
LeisureTime	20
LeisureTime Solar	21
LeisureTime AGP	22
Spa Blower	23

POOL FILTERS 25

Clean & Clear® Plus Filter	26
Posi-Clear RP™ Filter.....	28
FreeFlo Cartridge Filter.....	30
Tagelus® Sand Filter	32
Leisuretime® II Sand Filter	34
Media	36

POOL HEATING 37

MasterTemp® Heater.....	38
MasterTemp® 125.....	40
UltraTemp® VXi	42
UltraTemp® HXi	44

AUTOMATIC POOL CLEANERS 47

Prowler® 920.....	48
Racer® LS.....	49
Rebel® 2	50
Mako Shark®	51
Great White® II	51
Extension Hoses	52

POOL SANITIZERS 53

Posi-Chlor®	54
FreeFlo Chlorinator	55
IntelliChem®	56
Rainbow	57
IntelliChlor	58

POOL AUTOMATION 59

IntelliCentre®.....	60
EasyTouch® Control Systems.....	62
SunTouch® Control Systems.....	65
Guide to Pool Controls.....	66
IntelliValve®	67

POOL LIGHTS & WATER FEATURES 69

GloBrite® LED Lights	70
IntelliBrite® Compatible LED Lights.....	71
MagicStream® Laminar	72
ColourVision® LED Light Bubbler	73
Deck Jet & Deck Jet II	74
Pool Lighting Transformers	75

WHITE GOODS & VALVES 77

MegaSkim Skimmer.....	78
U-3 Skimmer	81
StarGuard® Main Drains.....	82
ONGA Main Drain.....	83
Hydrostatic Valves	83
Pool Specialty Fittings - Return Fittings	84
Pool Specialty Fittings - Versatile Fitting System	85
Pool Specialty Fittings - Inlets, Outlets & Unions	86
Automatic Water Fillers	87
Valves & Actuators	88

POOL PVC FITTINGS 89

MAINTENANCE EQUIPMENT 95

Value Range.....	96
Rainbow Range	97
Miscellaneous Parts	98
Handover Kit	99

COMMERCIAL POOL EQUIPMENT 101

Starline ISO.....	102
5PSP Series.....	104
PWT-V Commercial Filter.....	106
PWT-S Commercial Filter.....	107
PWT-SDB Commercial Filter.....	108
PWT-NL Commercial Filter	110
PWT Commercial Filter	112
PWT Commercial Heat Pumps	117

CONTENTS

POOL & SPA CHEMICALS 119

Pool Chemicals	120
Spa Chemicals	122

TERMS, ENGINEERING & WARRANTY 123

Terms & Conditions of Trade	124
Pentair Warranty Schedule	126
Engineering	128

PRODUCT SELECTION GUIDE

Choosing the best products for your specific requirements

STEP 1 IDENTIFY POOL SIZE

Pool Size (L)	Flow 6 hr Turnover (LPM)	Pool Size (L)	Flow 6 hr Turnover (LPM)
20,000	55	70,000	194
30,000	83	80,000	222
40,000	111	100,000	277
50,000	138	120,000	333
60,000	166	150,000	416

STEP 2 SELECT PUMP

Pumps	LPM @12m	Pumps	LPM @12m	Pumps	LPM @12m
Pantera		WhisperFlo		Max-E-Pro	
Pantera 550	100	WhisperFlo 750	175	Max-E-Pro 730	180
Pantera 750	160	WhisperFlo 1100	275	Max-E-Pro 930	230
Pantera 1100	220	WhisperFlo 1500	330	Max-E-Pro 1100	260
Pantera 1500	250	WhisperFlo 2100	425	Max-E-Pro 1500	375
LeisureTime		SilentFlo		Max-E-Pro 2200 440	
LTP400	75	SilentFlo 750	140		
LTP550	100	SilentFlo 1100	250		
LTP750	150	SilentFlo 1500	350		
LTP1100	220				

STEP 3 SELECT FILTER

Sand Filters			Cartridge Filters				
Filter	Flow (Lpm)		Filter	Flow (Lpm)		Filter	Max Flow (Lpm)
	Min*	Max*		Min*	Max*		
LeisureTime II			Tagelus				
LSFII-21-40	120	190	Tagelus 21"	130	190	CLEAN & CLEAR PLUS	FREEFLO
LSFII-25-40	180	260	Tagelus 24"	170	230	CNC240	340
LSFII-25-50	180	280	Tagelus 30"	280	380	CNC320	454
LSFII-28-50	230	350				CNC420	568
LSFII-32-50	270	415				CNC520	568
						POSI-CLEAR RP	
						RP100	380
						RP150	570
						RP200	570

STEP 4 SELECT CHLORINATOR

Chlorinator	Max Pool Size (L)		
	Mild	Temperature	Tropical
FFCL-15-RP	40,000	30,000	20,000
FFCL-25-RP	80,000	60,000	50,000
FFCL-35-RP	120,000	90,000	70,000
SR-20	60,000	45,000	35,000
SR-30	100,000	75,000	60,000

STEP 5 SELECT VARIABLE SPEED

Pump	Max. Pool Size (L)
Pantera Eco VS	50,000
EnviroMax 800	75,000
EnviroMax 1500	100,000
IntelliFlo VSF	150,000
IntelliFlo XF	200,000

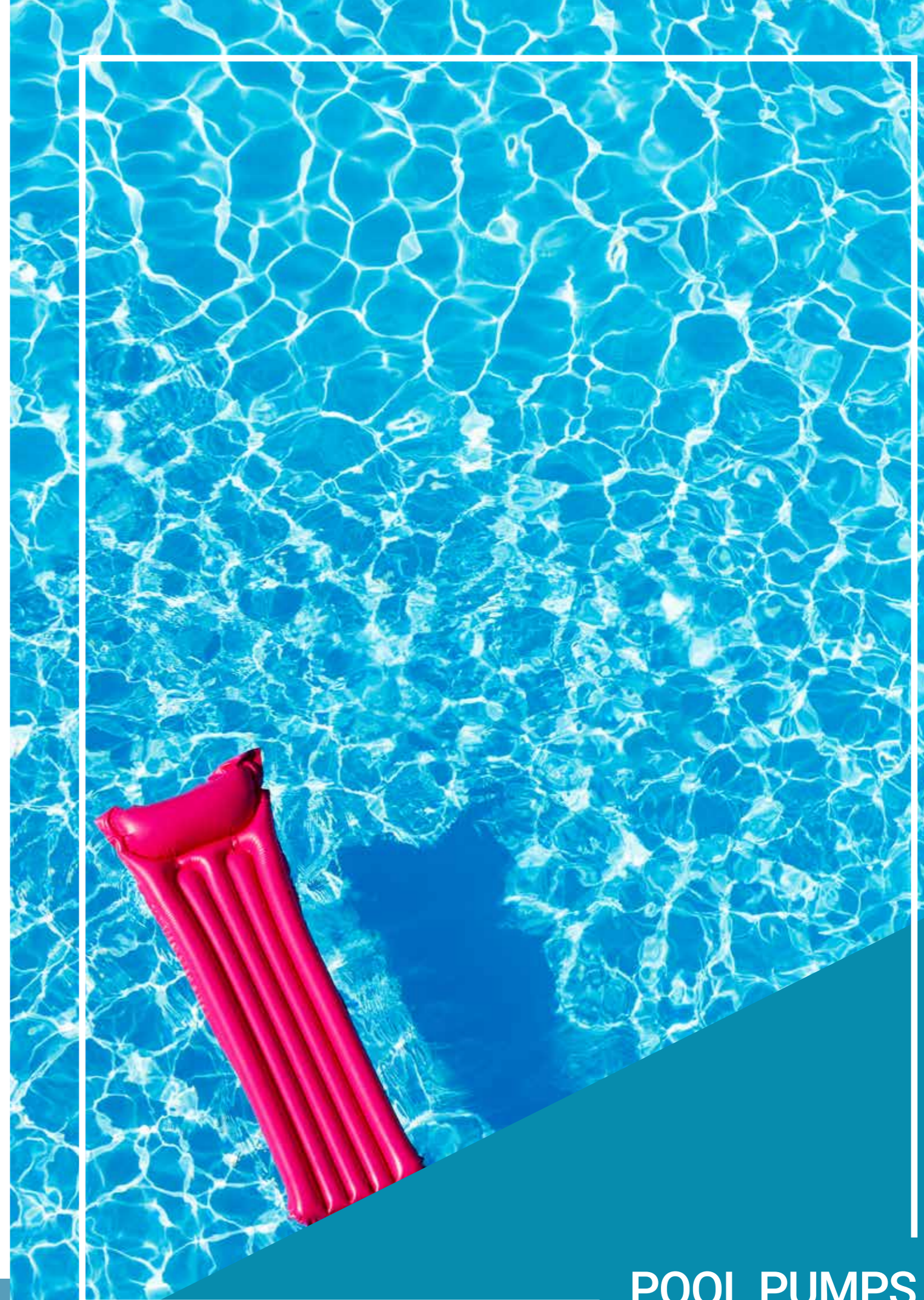

IntelliFlo® 2 VSF

Variable Speed & Flow Pump



FEATURES:

- Ability to program exact pump speeds or flows for specific operations – filtering, heating, cleaning, spa jets, water features and more. Reduces energy costs up to 90%.
- 50mm /2" barrel unions included.
- 8 speed and/or flow settings and on-board scheduling with timers.
- LCD screen with keypad for easy programming.
- Ultra-efficient permanent magnet motor design reduces noise and vibration for greater efficiency and longer pump life.
- Built-in diagnostics protect the IntelliFlo2 VSF pump from the most common causes of premature failure – loss of prime, overheating, freezing, and voltage irregularities.
- Fully compatible with IntelliTouch®, EasyTouch®, SunTouch® and other pool control systems.
- Robust On Board Power Factor Correction.
- 9 star energy rating.
- 5 year limited warranty.*



The world's first variable speed and flow pump that delivers the highest available efficiency and peak performance.

The IntelliFlo® 2 VSF pump is the first to adjust to changes in flow conditions to maintain its preprogrammed flow rate to run optimally throughout the entire filtration cycle. It's like having cruise control for your pump.

Since the IntelliFlo® 2 VSF pump is ultra energy efficient, you can experience increased energy savings, up to 90%, when compared to conventional single speed pumps.

INTELLIFLO 2 VSF VARIABLE SPEED / VARIABLE FLOW PUMP

MGP52

Code	Product	Voltage (VAC)	Full Load (A)	KW	HP	SF	SFHP	Freq.	Port Size	Carton Dim (mm).	Carton Weight (Kg.)	Pallet Qty.	Price
011056-AU	IntelliFlo® 2 VSF	230-240	15	3.2	3	1.32	3.95	50/60Hz	2"/50mm	725x325x390	23	12	\$5,260.59

ACCESSORIES - EXTERNAL CONTROL INTERFACES

MGP52

Code	Product	Input Voltage	Carton Dim (mm).	Carton Weight (Kg.)	Price
521109	IntelliComm II Interface Adaptor	9-24VAC, 9-24VDC	150x75x75	0.5	\$783.72
356905Z	Keypad Relocation Kit		350x350x150	1.5	\$160.00

*Terms and conditions apply

IntelliFlo® 2 VSF

Variable Speed & Flow Pump

ACCESSORIES

The IntelliComm II interface allows you to control the IntelliFlo pump with an alternative or custom control. The IntelliComm II has low voltage inputs up to 9-24V DC and controls the IntelliFlo via the communication cable.

NOTE: The IntelliComm II is not required to connect an IntelliFlo pump to a Pentair SunTouch, EasyTouch or IntelliTouch automation system.



IntelliComm II



Keypad Relocation Kit

DIMENSIONS AND PERFORMANCE*

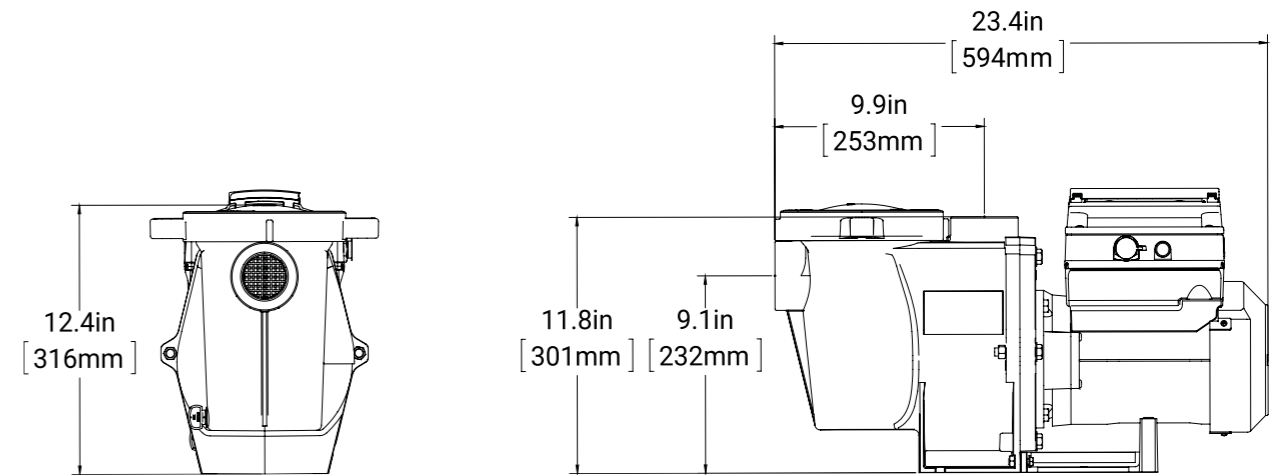
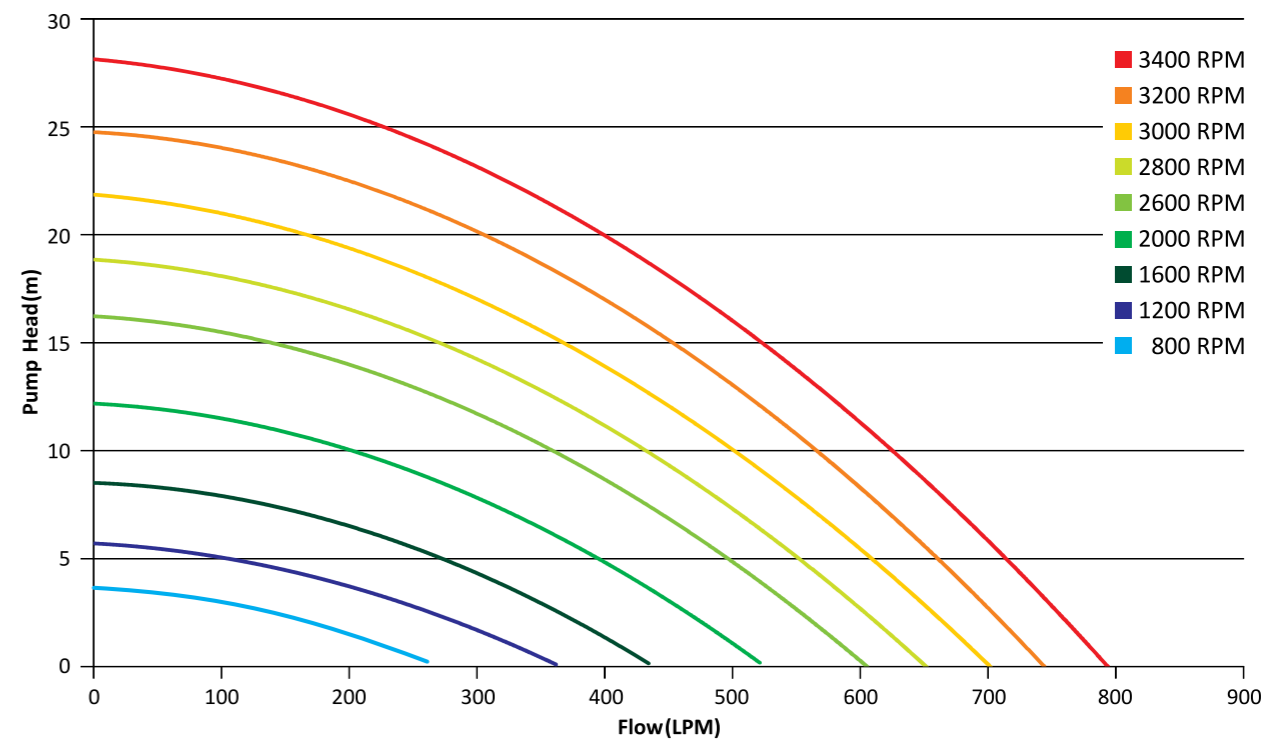

*All dimensions in mm.



FEATURES:

- **Quiet operation** - A specially designed sound dampening pump casing and base make pump operation incredibly quiet, enabling you to run the pump at night without disturbing the neighbours and take advantage of the off-peak tariffs.
- **High efficiency** - Precision-fit internal components and superior hydraulic design deliver effortless performance, energy savings and extended pump life.
- **Elevated base** - Further dampens sound and vibration for even quieter operation and keeps the pump above sitting water which minimises corrosion.
- **Large volume Strainer basket** - Minimises the maintenance requirement by extending the time between strainer basket clean outs.
- **Dual connections** - 50mm thread or 50mm quick disconnect barrel unions (included).
- **Cam & Ramp™ lid** - Easy to remove, locks in place with a quarter turn, making inspection and cleaning a breeze.
- 3 years limited warranty.*



The Sta-Rite SilentFlo is an ultra-quiet, high-efficiency, self-priming, medium head pump in 3/4 through 2hp with an extra large, integral hair and lint strainer. SilentFlo is precision moulded with Pentair's innovative thermoplastic composite resin that is not only tough and highly corrosion resistant but is design to dampen the noise created by the pump giving ultra-quiet operation. SilentFlo features a high quality mechanical seal, stainless steel shaft and fasteners which will ensure that this pump will give top performance and reliability for years to come.

DIMENSIONS AND PERFORMANCE*

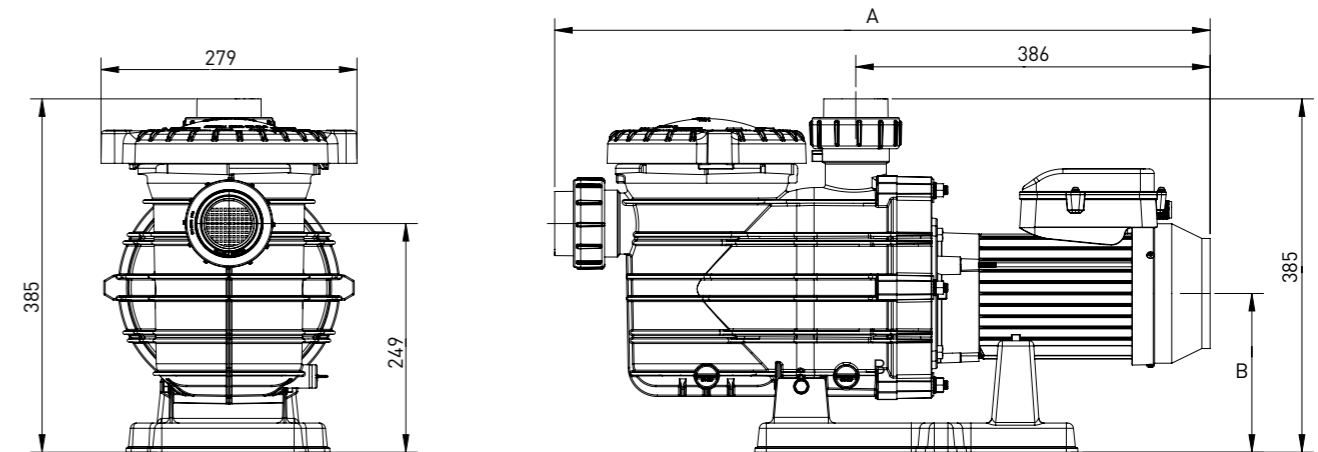
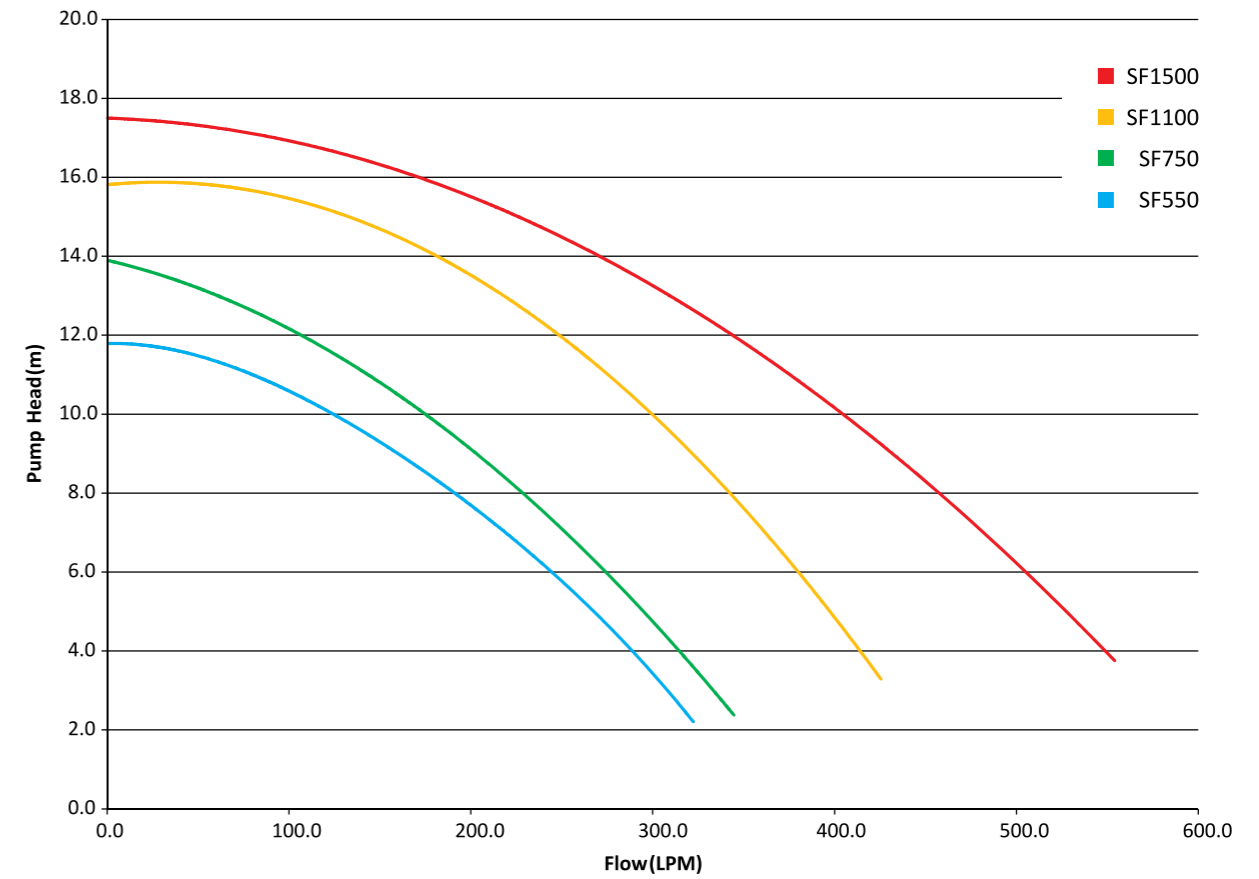

SILENTFLO – ULTRA QUIET HIGH EFFICIENCY SINGLE PHASE

MPG52

Code	Product	Voltage (VAC)	Full Load (A)	Power Input (P1,W)	Power Output (P2,W)	Nominal Power (hp)	Locked Rotor Current (A)	Capacitor (uF)	Carton Dim (mm)	Carton Weight (Kg.)	Pallet Qty.	Price
SF550100	SilentFlo 550W	230 - 240	2.6	600	450	0.75	14	25	725x325x390	16.5	12	\$1,604.10
SF750103	SilentFlo 750W	230 - 240	3.3	740	550	1.0	14	25	725x325x390	16.5	12	\$1,717.15
SF1100100	SilentFlo 1100W	230 - 240	5.0	1050	790	1.5	22	25	725x325x390	19.5	12	\$1,863.81
SF1500100	SilentFlo 1500W	230 - 240	6.7	1590	1190	2.0	28	35	725x325x390	22	12	\$2,054.78

Pump Model	SF550	SF750	SF1100	SF1500
A (mm)	616	616	637	677
B (mm)	173	173	179	179

*Terms and conditions apply

*All dimensions in mm.

EnviroMAX® 800, 1500

Energy Efficient Variable Speed Pump



EnviroMAX® 800, 1500

Energy Efficient Variable Speed Pump



FEATURES:

- EnviroMax 1500 features a built in time-clock (which can be disabled) that allows the pump to operate independently of a salt chlorinator.
- EnviroMax 1500 features an auto advance feature, which allows the pump to automatically change speeds when running from a conventional salt chlorinator.
- **Powerful Head and Flow** - Increased head and flow makes pump suitable for spa jets, in-floor cleaning and other high demand applications.
- **Adjustable Priming** - Set desired priming speed or deactivate altogether.
- **Power Factor Correction** - EnviroMAX® 1500 has a power factor >0.9 which means the power consumption shown on our energy label, is what you are actually charged for.
- **Digital Control Input** - For connection to automation systems.
- **Tough and Durable** - Pump made from Dura-Glas™ composite, reinforced, resin. UV and weather resistant.
- **Quiet Operation** - Our quietest EnviroMAX® yet.
- **Precision Fit Components** - Precision engineering for quality, reliability and efficiency.
- 8-Star Energy Rating.
- 3 Year Warranty.

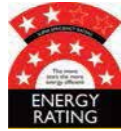

New EnviroMAX® Variable Speed Pumps bring the remarkable energy cost savings of variable speed technology to everyday pools that require up to a 2.0-HP pump. They dramatically reduce energy costs by moving water more efficiently at lower speeds.

Building on the success of previous EnviroMAX® pool pumps, the new EnviroMAX® 1500 and 800 models add higher output so you can do more; filtration, spa jets, water features and even in-floor cleaning.

DIMENSIONS AND PERFORMANCE*

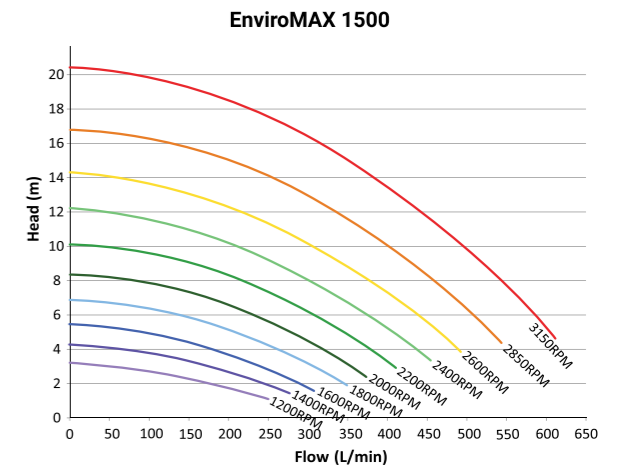
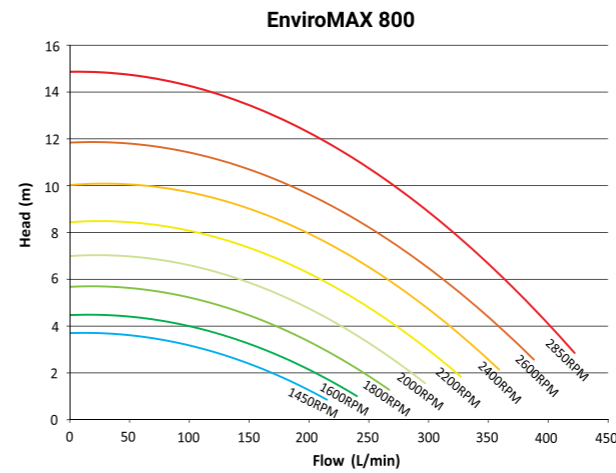

EnviroMAX 800

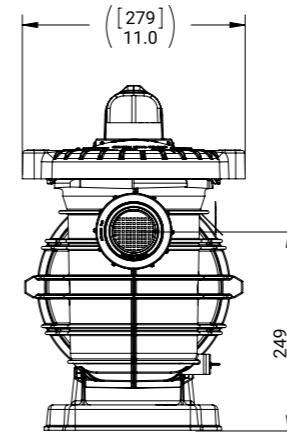

FRONT VIEW

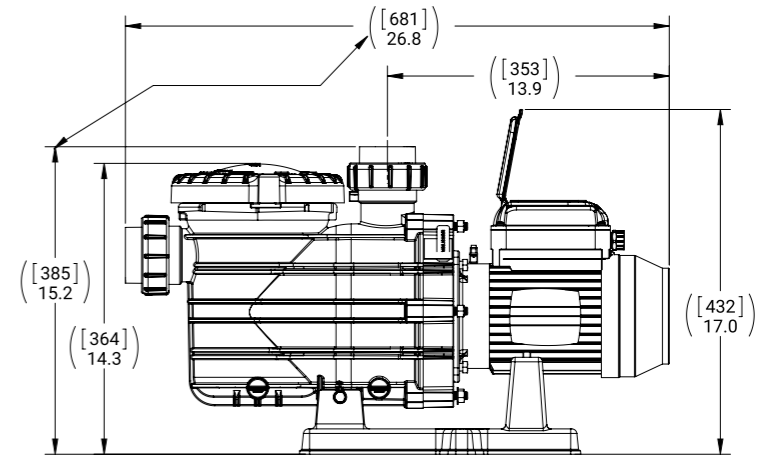

SIDE VIEW

EnviroMAX 1500

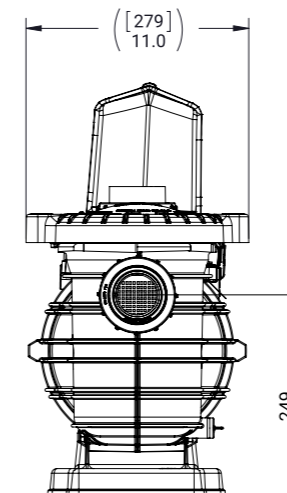

FRONT VIEW

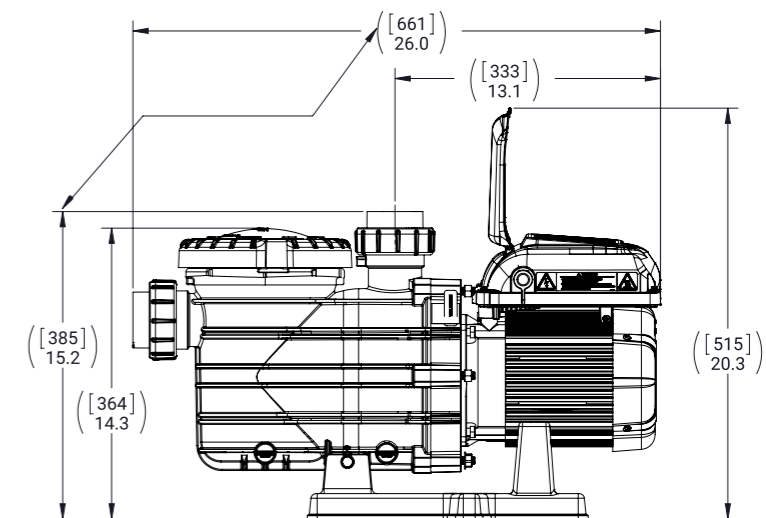

SIDE VIEW

ENVIROMAX – VARIABLE SPEED PUMP

MPG20

Code	Product	Voltage (VAC)	Full Load (A)	Power Input (P1,W)	Power Output (P2,W)	Power (hp)	Locked Rotor Current (A)	Capacitor (uF)	Carton Dim (mm)	Carton Weight (kg)	Pallet Qty.	Price
EVMX800	EnviroMax 800	230-240	Full Range	1000-2850	6.5	975	800	1.0	725x325x390	22	12	\$2,769.75
EVMX1500	EnviroMax 1500	230-240	Full Range	600-3150	9.6	2100	1700	1.5	725x325x390	22	12	\$3,411.39

ENVIROMAX – ACCESSORIES

MPG20

Code	Product	Price
800018	EnviroMax 800 Automation Cable	\$93.71
353129Z	EnviroMax 1500 Automation Cable	\$93.71

*Terms and conditions apply

*All dimensions in mm.



FEATURES:

- **Typical Installation** – Inground pools, pool/spa combinations, inground spas, fountains and water features.
- **Self-priming** – Suction lift up to 4.5m above water level.
- **Easy-to-Install** – 2"/50mm ports include external and internal threads for more plumbing options.
- **Superior Hydraulic Design** – Moves larger volumes of water, resulting in lower operating costs.
- **Impeller Manufactured with PPO Resin** – Withstands the toughest water environments.
- **Fluoroelastomer Rubber Shaft Seal** – Longer-lasting seal stands up to the harshest environments.
- **Self-lubricating Lid O-Ring** – Does not require lubricant.
- 3 years limited warranty.*



Max-E-Pro – High efficiency, low maintenance and maximum performance—all the features demanded by today's pool professionals. The Max-E-Pro pump has our new Quick-Lock™ trap cover ring and the 50mm / 2 in. Ports incorporate internal and external threads. Available in single and three phase models, with ratings from 1 to 3 HP.

Built with quality construction using a durable one-piece pump housing constructed of Dura-Glas™ – Pentair's industry leading glass-reinforced composite resin. Fast cleaning with a Quick-Lock trap cover ring permits fast access to strainer basket. Large see through lid makes it simple to check for debris. A strong, sturdy, specially designed base dampens sound and vibration, making the Max-E-Pro pump one of the quietest pumps in its class.

MAX-E-PRO POOL PUMP

MPG52

Code	Product	Voltage (VAC)	Full Load (A)	Power Input (P1,W)	Power Output (P2,W)	Power (hp)	Locked Rotor Current (A)	Capacitor (uF)	Carton Dim (mm)	Carton Weight (kg)	Pallet Qty.	Price
SINGLE PHASE												
MP730100	Max-E-Pro 730	230-240	4.1	925	690	1	14	25	725x325x390	16.5	12	\$2,303.80
MP930100	Max-E-Pro 930	230-240	5.4	1160	870	1.25	22	25	725x325x390	19.5	12	\$2,505.45
MP1100100	Max-E-Pro 1100	230-240	6.0	1330	1000	1.5	22	25	725x325x390	19.5	12	\$2,566.56
MP1500100	Max-E-Pro 1500	230-240	7.9	1800	1350	2	28	35	725x325x390	22.5	12	\$2,965.30
MP2201100	Max-E-Pro 2200	230-240*	10.7	2435	1950	3	42	2x25	725x325x390	27.5	12	\$3,382.36
THREE PHASE												
MP1108100	Max-E-Pro 1100	400-415	2.7	1250	1000	1.5	23	-	725x325x390	28	12	\$2,635.31
MP1508100	Max-E-Pro 1500	400-415	4.2	2100	1690	2	23	-	725x325x390	28	12	\$3,052.38
MP2208100	Max-E-Pro 2200	400-415	4.4	2420	1980	3	38	-	725x325x390	30	12	\$3,478.61

*Terms and conditions apply.
*MP2201100 is equipped with a 15A lead

DIMENSIONS AND PERFORMANCE*

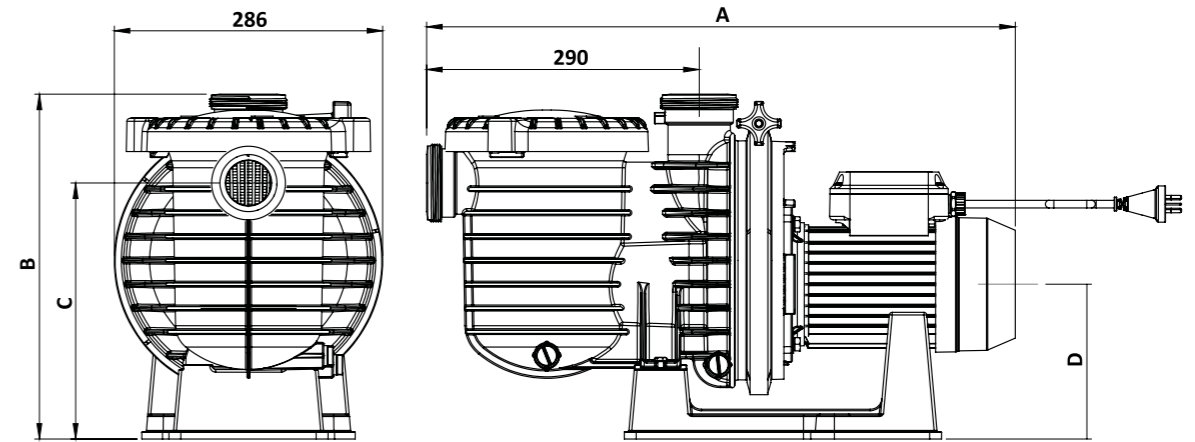
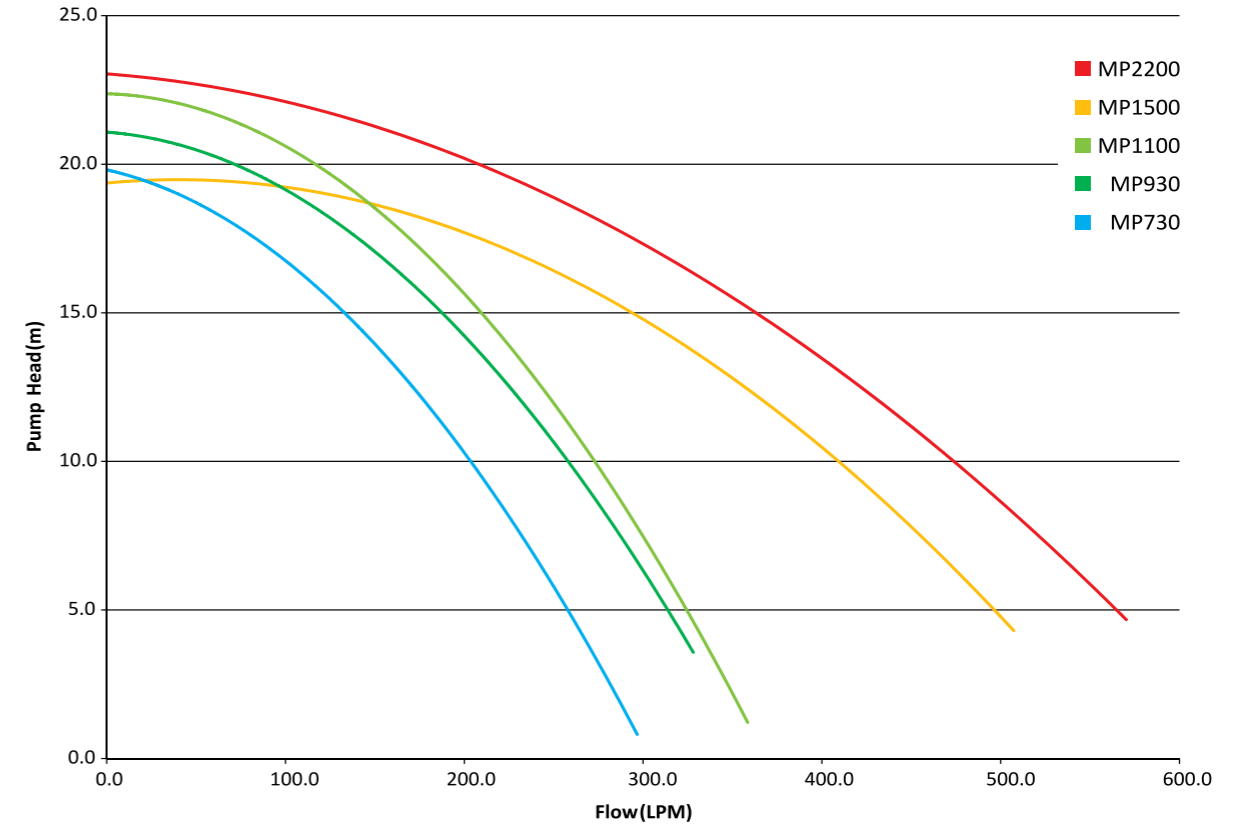

Pump Model	MP730100	MP930100	MP1100100	MP1108100	MP1500100	MP1508100	MP2200100	MP2208100
A (mm)	629	650	650	696	690	721	694	721
B (mm)	374	374	374	374	374	374	374	374
C (mm)	280	280	280	280	280	280	280	280
D (mm)	165	171	171	187	171	187	181	187

*All dimensions in mm.



FEATURES:

- Unique FunnelFlo™ diffuser and high-efficiency impeller maximising water flow and energy efficiency whilst minimising turbulence and noise.
- Specially engineered design assures whisper-quiet operation.
- Oversized strainer basket and volute extends time between cleaning.
- See-through lid makes inspection fast and easy and the engineered polymer will remain clear for years.
- Lower HP's deliver higher performance than industry standard.
- Compatible with all cleaning systems, various filters and jet action spas.
- Heavy-duty/durable construction is designed for long life.
- Designed for residential and commercial applications.
- User friendly Cam & Ramp™ lid is easy to remove and quickly locks in place with a quarter turn.
- 50mm /2" barrel unions included.
- 3 years limited warranty.*



We call it the WhisperFlo pump for good reasons. The innovative hydraulic design moves water more efficiently and more quietly than conventional pumps. Our legendary hydraulic design has been refined over 40 years for superior performance. Under typical operating conditions, WhisperFlo delivers high water flow with low electrical consumption.

WhisperFlo is designed to be a tireless workhorse, its engineered thermoplastic housing withstands extreme heat and resists corrosion. The commercial grade motor has a rust-resistant, stainless steel shaft and sealed bearings that never need lubrication. Engineered to provide optimum performance in any size pool and spa combination.

DIMENSIONS AND PERFORMANCE*

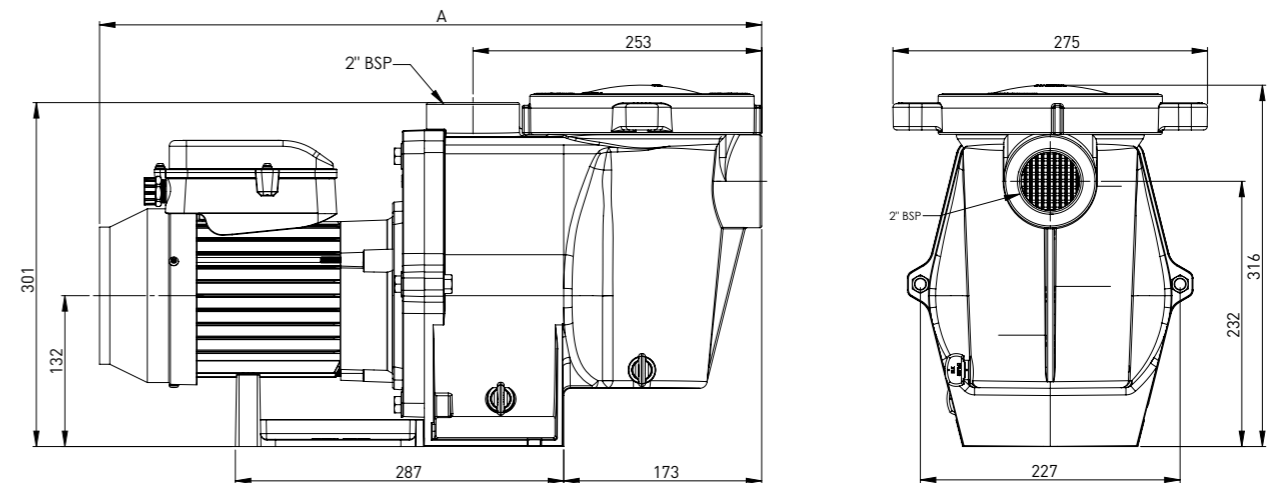
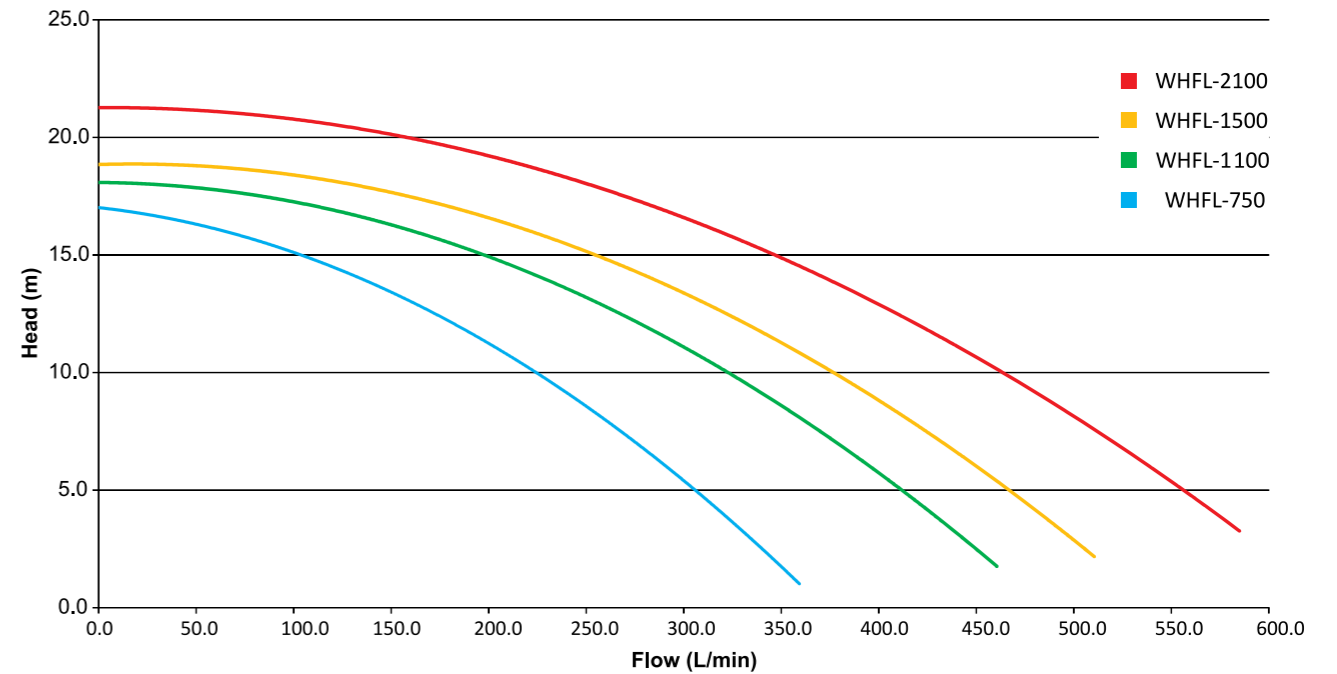

WHISPERFLO - HIGH PERFORMANCE PUMPS

MPG52

Code	Product	Voltage (VAC)	Full Load (A)	Power Input (P1,W)	Power Output (P2,W)	Nominal Power (hp)	Locked Rotor Current (A)	Capacitor (uF)	Carton Dimensions (mm)	Carton Weight (kg)	Pallet Qty.	Price
WHFL-750-1P	WhisperFlo 750	230-240	3.8	890	670	1	14	25	725x325x390	15	12	\$1,579.66
WHFL-1100-1P	WhisperFlo 1100	230-240	5.5	1260	945	1.5	22	25	725x325x390	19.5	12	\$1,724.79
WHFL-1500-1P	WhisperFlo 1500	230-240	6.3	1490	1120	2	28	35	725x325x390	22	12	\$1,917.28
WHFL-2100-1P	WhisperFlo 2100	230-240	9.0 [^]	2020	1610	3	42	2x25	725x325x390	27	12	\$2,314.49

*Terms and conditions apply.

[^] WhisperFlo 2100 is equipped with a 15A plug.

*All dimensions in mm.

Pump Model	WHFL750	WHFL1100	WHFL1500	WHFL2100
A (mm)	570	580	620	620



IntelliFlo XF Pump



WhisperFlo XF Pump

FEATURES:

- Extremely quiet operation.
- Extra-large basket needs less emptying, with a smooth surface for easy debris removal.
- Self-priming for quick, easy start-up.
- User-friendly Cam & Ramp™ with see through lid, locks into place with a quarter turn for easy cleaning and maintenance.
- Diamond Seal, o-rings made from oxidation resistant EPDM rubber for superior long-lasting, leak-resistant performance.
- Integral volute and pot reduce hydraulic noise.
- Proprietary hydraulic isolator satisfies the competing priorities of smooth priming and optimally efficient operation.
- Union connectors included to connect directly to 63mm / 2.5" or 80mm / 3" plumbing.
- 3 years limited warranty.



Now there's a pool pump for demanding high-capacity applications that's energy efficient, whisper-quiet and dependable. The WhisperFlo XF and IntelliFlo XF pumps bring best-in-class energy efficiency, near-silent operation and ultra-dependable performance to high-capacity pool pumps.

Driven by innovation, when we developed this breakthrough pump, we relied on today's computer-aided design and manufacturing (CAD/CAM) plus computational fluid dynamics (CFD) to deliver the best WhisperFlo and IntelliFlo pump we've ever made.

The reward for our hard work is the WhisperFlo XF and IntelliFlo XF pumps with energy efficiency that's unsurpassed by any pump in its class. A higher standard of performance, the WhisperFloXF and IntelliFlo XF pumps are the most efficient, technologically advanced high-capacity pump ever to wear the venerable Pentair badge. With outstanding performance from both a maximum-flow and mean-flow perspective, it's perfectly suited for small commercial pools as well as larger residential pools.

INTELLIFLO XF POOL PUMP

MPG24

Code	Product	Voltage (VAC)	Full Load (A)	Power Input (P1,W)	Power Output (P2,W)	Nominal Power (hp)	Locked Rotor Current (A)	Capacitor (uF)	Carton Dimensions (mm)	Carton Weight (kg)	Pallet Qty.	Price
22005	IntelliFlo XF	230-240	15	3200	2200	3	-	-	725x325x390	27	12	\$6,095.59

WHISPERFLO XF POOL PUMPS

MPG52

Code	Product	Voltage (VAC)	Full Load (A)	Power Input (P1,W)	Power Output (P2,W)	Nominal Power (hp)	Locked Rotor Current (A)	Capacitor (uF)	Carton Dimensions (mm)	Carton Weight (kg)	Pallet Qty.	Price
WHFL-2100-XF	Whisperflo XF 2100W 1 Phase	230-240	8.5	1930	1600	2	42	2x25	725x325x390	29	12	\$3,038.63
WHFL-2200-XF3P	Whisperflo XF 2200W 3 Phase	230-240	15	3200	2200	3	-	-	725x325x390	27	12	\$3,388.47

*Terms and conditions apply.

DIMENSIONS AND PERFORMANCE*

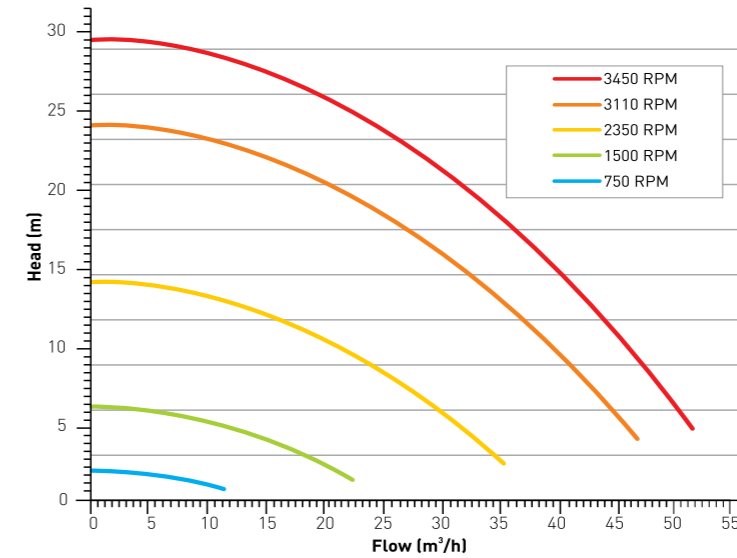

• INTELLIFLO XF

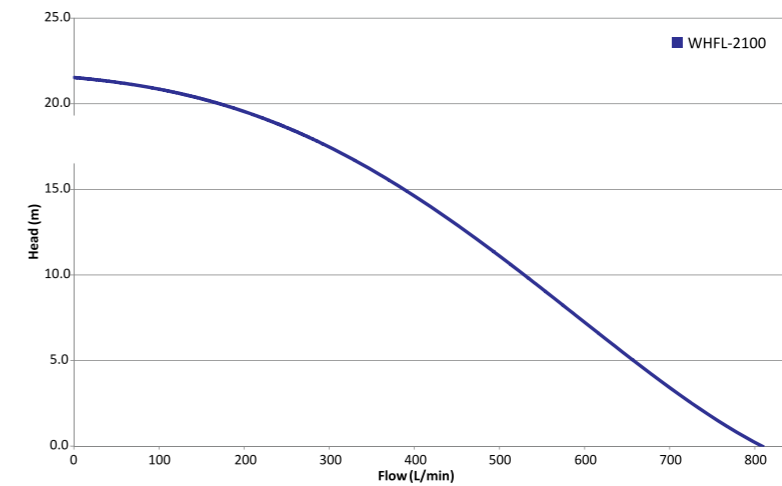

• WHISPERFLO XF

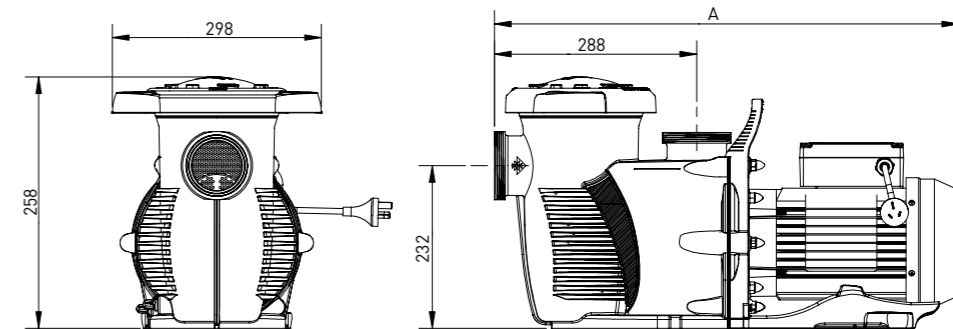

Pump Model	WHISPERFLO XF	INTELLIFLO XF
A (mm)	662	633

*All dimensions in mm.

Pantera Evolution

High Efficiency 2-Speed Pump



FEATURES:

- Dual speed pump, with 2 fixed speeds, allows you to efficiently filter your pool, saving energy with the low speed mode and delivering extra power with the high speed mode for backwashing and vacuuming.
- 2 pole / 4 pole induction motor delivers high efficiency and low noise levels.
- Electronic control features high speed priming, 2 hour high speed boost mode and sync mode for added functionality
- Drop in replacement for all LeisureTime and PPP pool pumps.
- 3 years limited warranty.*

The Pantera Evolution utilise efficient hydraulic design and the latest technology in electronic control two speed motors. The Pantera Evo' delivers energy savings for a realistic cost outlay and the power when you need it.



DIMENSIONS AND PERFORMANCE*

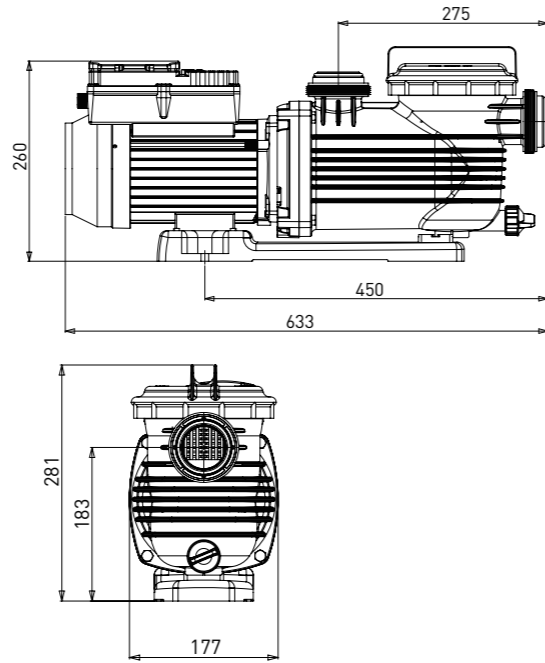
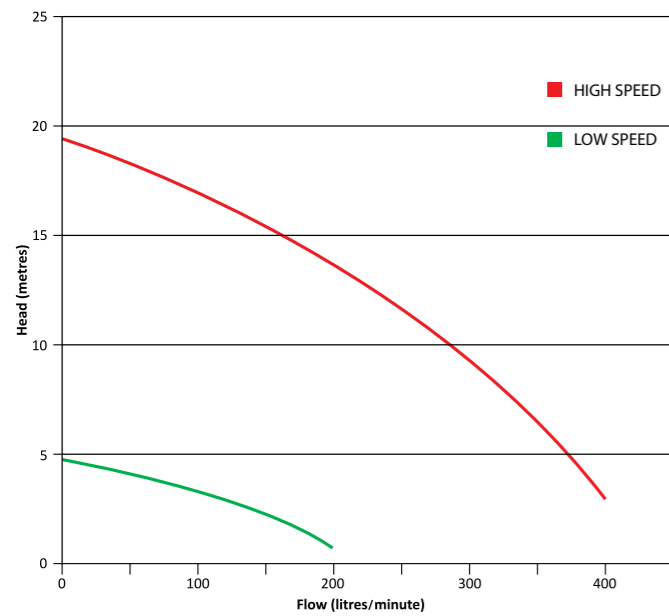

PANTERA EVOLUTION POOL PUMP

MPG22

Code	Product	Voltage (VAC)	Speed	Speed (RPM)	Full Load (A)	Power Input (P1,W)	Power Output (P2,W)	Carton Dimensions (mm)	Carton Weight (kg)	Pallet Qty.	Price
PPP-950-2SP	Pantera Evo 2 Speed	230-240	LOW	1400	1.0	223	118	660x240x305	16	32	\$1,964.64

*Terms and conditions apply. *All dimensions in mm.



Pantera

High Performance Pump



FEATURES:

- Stainless steel motor shaft - A 5/8" 316 Stainless Steel shaft extends the life of the pump.
- Shaft Sleeve - A nylon shaft sleeve incorporating a flinger, adds additional water ingress protection.
- Mechanical Seal - A heavy-duty 3/4" 316 Stainless Steel mechanical seal (on all models) provides extended life and longer intervals between servicing.
- Plastic Yoke and Lip-Seal - The wet end design integrates a moulded end-shield cover and lip seal, protecting the motor from water damage.
- Self aligning barrel unions (40mm/50mm) included.
- 3 years limited warranty.*

Pantera pumps are high performance pumps with 5 levels of corrosion resistance.



DIMENSIONS AND PERFORMANCE*

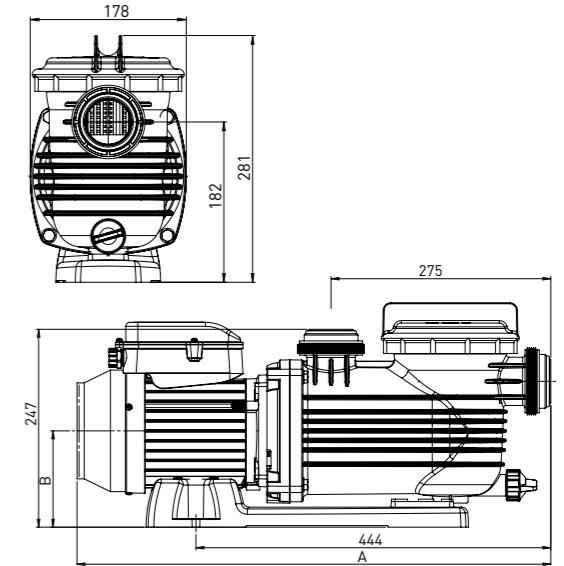
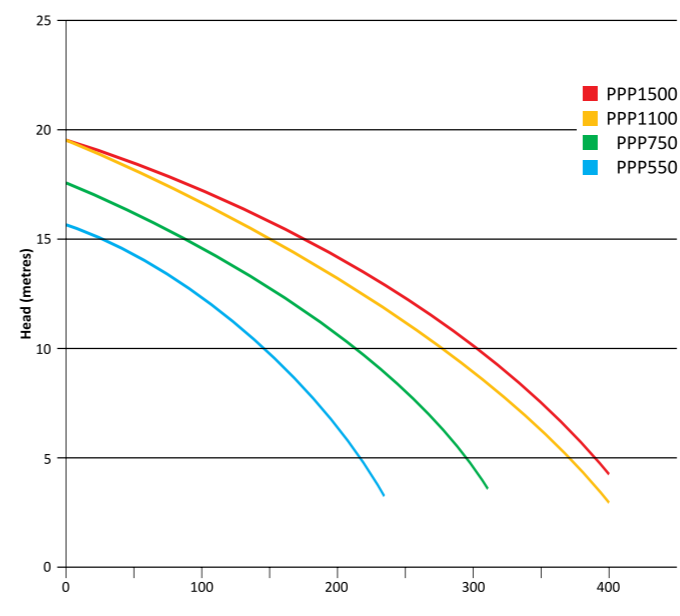

Pump Model	PPP-550-1P	PPP-750-1P	PPP-1100-1P	PPP-1500-1P
A (mm)	575	575	593	593
B (mm)	121	121	121	121

PANTERA POOL PUMP

MPG22

Code	Product	Voltage (VAC)	Full Load (A)	Power Input (P1,W)	Power Output (P2,W)	Nominal Power (hp)	Locked Rotor Current (A)	Capacitor (uF)	Carton Dimensions (mm)	Carton Weight (kg)	Pallet Qty.	Price
PPP-550-1P	Pantera 550	230-240	3.6	825	550	0.75	17	20	660x240x305	14	32	\$1,315.36
PPP-750-1P	Pantera 750	230-240	3.9	920	690	1.0	17	20	660x240x305	14	32	\$1,350.50
PPP-1100-1P	Pantera 1100	230-240	5.0	1200	900	1.25	21	25	660x240x305	15	32	\$1,541.47
PPP-1500-1P	Pantera 1500	230-240	6.1	1360	1020	1.5	21	25	660x240x305	15	32	\$1,756.87

*Terms and conditions apply. *All dimensions in mm.

LeisureTime

High Performance Pump



FEATURES:

- New look casing, compatible with previous models.
- New tough impact and UV resistant casing.
- Epoxy coated end-shield.
- Stainless steel shaft and mechanical seal.
- Self aligning barrel unions - Onga's unique 5 degree self-aligning barrel unions make pipework connection a breeze. (40mm/50mm) included.
- IPX5 Totally Enclosed Fan Cooled Motor (TEFC) - protects against water and dust whilst keeping the motor cool.
- Self-priming.
- Built in on-winding thermal overload motor protection.
- Elevated motor foot.
- 2 years limited warranty.*

The LeisureTime range of inground ground pool pumps are great economical pumps ideal for small to medium in-ground pool systems. Sized from 1/2 to 1.5Hp they are purposefully designed to provide maximum performance at a realistic cost.



DIMENSIONS AND PERFORMANCE*

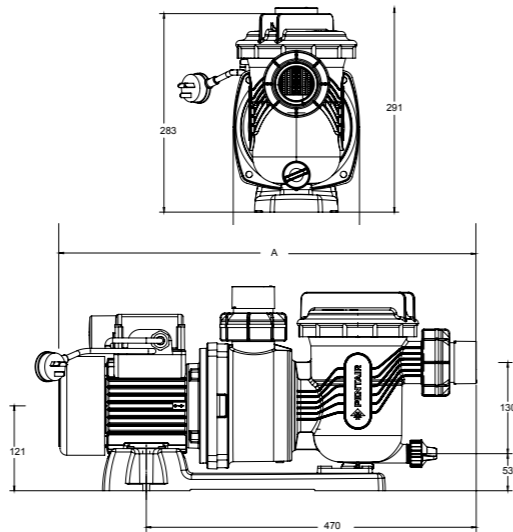
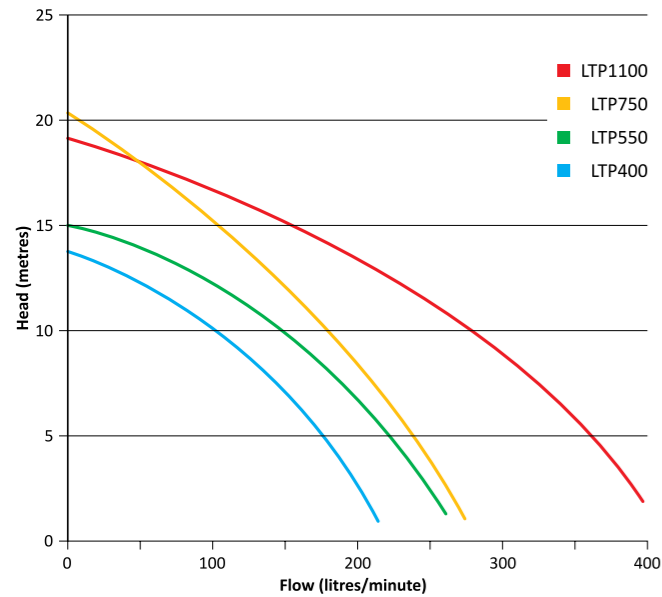

Pump Model	LTP400	LTP550	LTP750	LTP1100
A (mm)	526	535	535	583

LEISURETIME POOL PUMP

Code	Product	Voltage (VAC)	Full Load (A)	Energy Star Rating	Power Input (P1,W)	Power Output (P2,W)	Nominal Power (hp)	Locked Rotor Current (A)	Capacitor (uF)	Carton Dimensions (mm)	Carton Weight (kg)	Pallet Qty.	Price
LTP400	LeisureTime 400	230-240	2.7	-	585	400	0.5	10	12	610x320x200	11	48	\$982.32
LTP550	LeisureTime 550	230-240	3.5	1.5	785	550	0.75	17	20	610x320x200	14	48	\$1,018.99
LTP750	LeisureTime 750	230-240	4.3	1.0	930	700	1.0	17	20	610x320x200	14	48	\$1,063.29
LTP1100	LeisureTime 1100	230-240	5.4	1.5	1200	900	1.25	21	25	610x320x200	15	48	\$1,324.53

*Terms and conditions apply. *All dimensions in mm.



LeisureTime Solar

Solar Heating Pumps



FEATURES:

- IPX5 Totally Enclosed Fan Cooled Motor (TEFC) - protects against water and dust whilst keeping the motor cool.
- Self-priming.
- Built in on-winding thermal overload motor protection.
- Self aligning barrel unions - Onga's unique 5 degree self-aligning barrel unions make pipework connection a breeze. (40mm/50mm included).
- Built in drain-down clacker.
- Electrophoretic coated end-shield.
- Stainless steel shaft and mechanical seal.
- 2 year limited warranty.*

Specially designed to handle hot water generated from solar heating banks. They offer unique corrosion protection with an electrophoretic coated end-shield. Sized from 1/2 to 1Hp to meet most solar heating requirements.



DIMENSIONS AND PERFORMANCE*

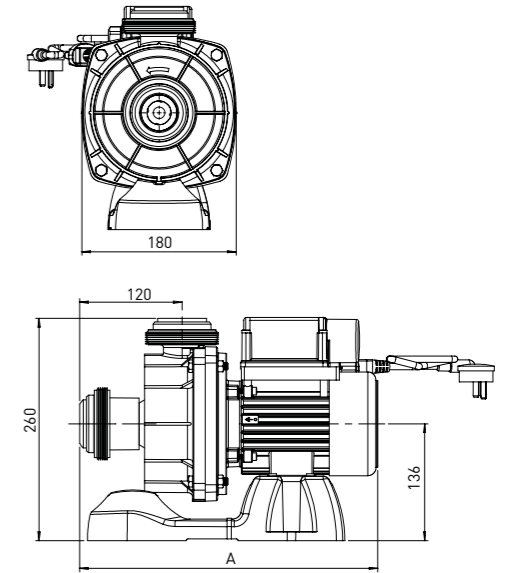
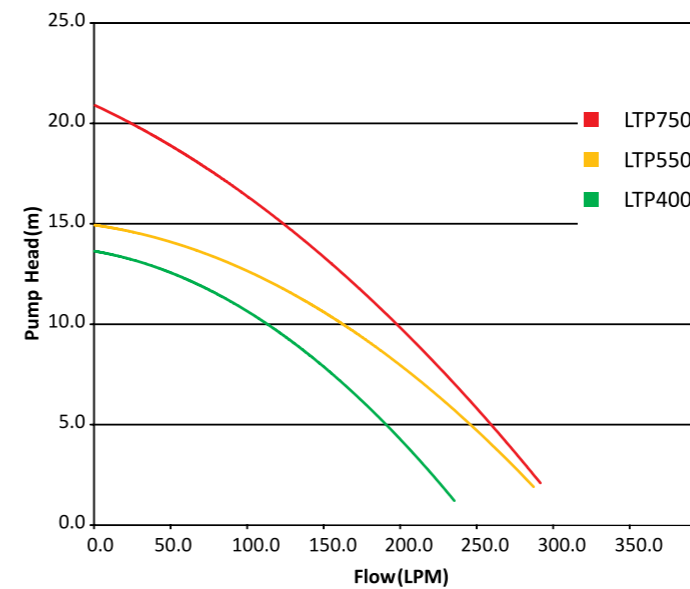

Pump Model	LTP400S	LTP550S	LTP750S
A (mm)	347	356	356

LEISURETIME SOLAR POOL PUMP

Code	Product	Voltage (VAC)	Full Load (A)	Power Input (P1,W)	Power Output (P2,W)	Nominal Power (hp)	Locked Rotor Current (A)	Capacitor (uF)	Carton Dimensions (mm)	Carton Weight (kg)	Pallet Qty.	Price
LTP400S	LeisureTime Solar 400	230-240	2.7	585	400	0.5	10	12	450x220x310	9.5	48	\$944.13
LTP550S	LeisureTime Solar 550	230-240	3.5	785	550	0.75	17	20	450x220x310	12.5	48	\$971.63
LTP750S	LeisureTime Solar 750	230-240	4.3	930	700	1.0	17	20	450x220x310	12.5	48	\$1,035.79

*Terms and conditions apply. *All dimensions in mm.

LeisureTime AGP

Above Ground Pump



FEATURES:

- IPX5 Totally Enclosed Fan Cooled Motor (TEFC) - protects against water and dust whilst keeping the motor cool.
- Self-priming.
- Built in on-winding thermal overload motor protection.
- Electrophoretic coated end-shield.
- Stainless steel shaft and mechanical seal.
- 2 year limited warranty.*

The LeisureTime range of above ground pool pumps are great economical pumps ideal for small to medium above ground pool systems. Sized from 1/2 to 1Hp they are purposefully designed to provide maximum performance at a realistic cost.



DIMENSIONS AND PERFORMANCE*

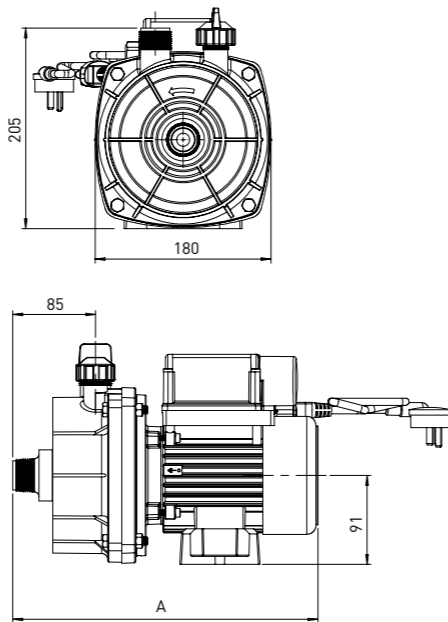
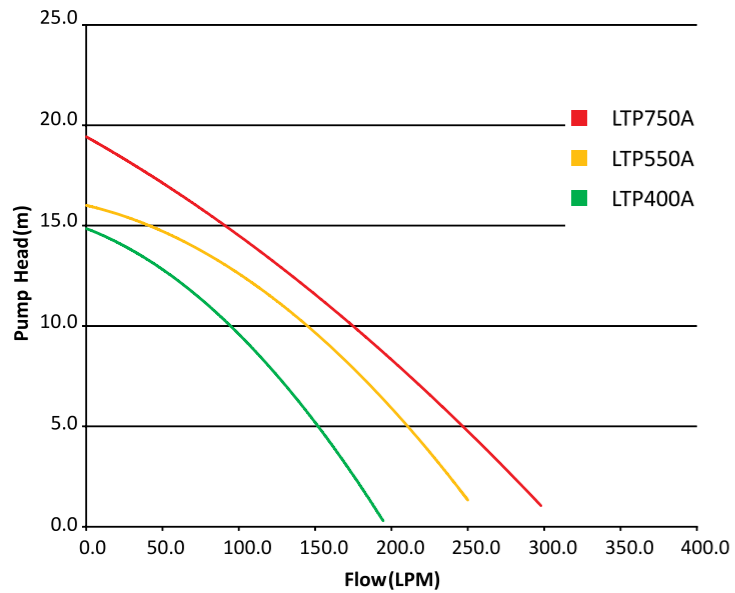

Pump Model	LTP400A	LTP550A	LTP750A
A (mm)	313	322	322

LEISURETIME ABOVE GROUND PUMP

MPG22

Code	Product	Voltage (VAC)	Full Load (A)	Power Input (P1,W)	Power Output (P2,W)	Nominal Power (hp)	Locked Rotor Current (A)	Capacitor (uF)	Carton Dimensions (mm)	Carton Weight (kg)	Pallet Qty.	Price
LTP400A	LeisureTime Above Ground 400	230-240	2.7	585	400	0.5	10	12	450x220x310	8.5	48	\$944.13
LTP550A	LeisureTime Above Ground 500	230-240	3.5	785	550	0.75	17	20	450x220x310	11.5	48	\$971.63
LTP750A	LeisureTime Above Ground 750	230-240	4.3	930	700	1	17	20	450x220x310	11.5	48	\$1,035.79

*All dimensions in mm.



Spa Blower

High Performance Pool Blower

POOL PUMPS



FEATURES:

- High performance blower motor moves more energy with less effort.
- Optimised design using acoustic testing to minimise noise output.
- Incorporated sound deadening foam.
- Non-return valve to prevent returning water damage.
- Fits to standard 50mm PVC pipe.
- EMC filter to eliminate radio interference.
- 1 year limited warranty.**

For greater levels of spa indulgence. The Onga blower adds the revitalising touch of warm swirling water enriched with millions of bubbles on your body in the ultimate therapeutic pleasure. In perfect harmony with your spa bath the Onga Spa Pool Blowers deliver a strong, reliable massage.

*Call for availability.



DIMENSIONS AND PERFORMANCE*

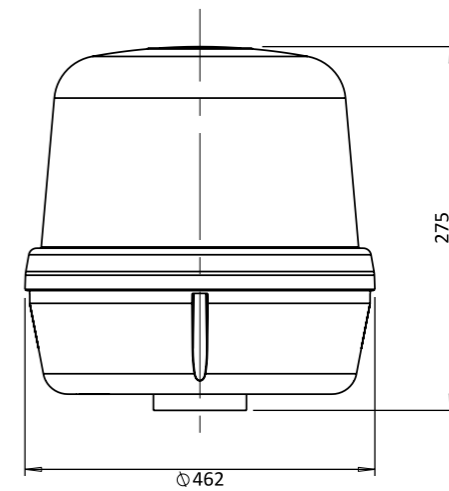
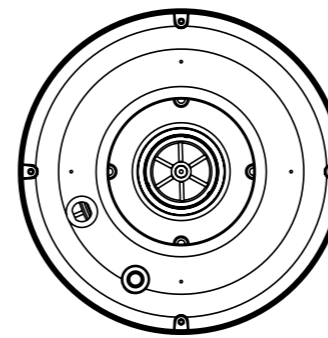

SPA BLOWER

MPG22

Code	Product	Voltage (VAC)	Full Load (A)	Carton Dimensions (mm)	Carton Weight (kg)	Pallet Qty.	Price
1043000	1200W Spa Pool Blower No Air Switch	230 - 240	6.3	280x270x310	4.7	64	\$918.37
1043100	1200W Spa Pool Blower + Air Switch	230 - 240	6.3	280x270x310	4.8	64	\$958.29

*Terms and conditions apply. *All dimensions in mm.

Clean & Clear® Plus Filter

High Capacity 'Mega' Cartridge Filter



FEATURES:

- Large filter area for increased dirt capacity.
- 1-1/2 in, 100% drain clean-out port.
- Continuous High Flow™ internal air relief.
- Injection molded, glass reinforced, polypropylene tank for superior strength.
- Balanced hydraulic flow.
- Tension Control™ clamp.
- 50mm barrel unions.
- 1/4 Turn manual air relief valve with hose port.
- 10 year pro-rata warranty.*

Clean & Clear® Plus Filters have a corrosion resistant injection molded filter tank featuring superior strength and reliability. The cartridge assembly uses four easy to clean, non-woven, polyester cartridges. Each filter is supplied with a bulkhead union set for easy installation.



CLEAN & CLEAR PLUS FILTERS

										MPG53
Code	Model	Effective Filtration Area (ft ² /m ²)	Max Flow Rate (LPM)	Turnover Capacity (in Litres)			Carton Dimensions (mm)	Carton Weight (Kg)	Pallet Qty.	Price
				8 Hour	10 Hour	12 Hour				
160426	Clean and Clear Plus Filter 240 sq ft	240/22.3	340	163,530	204,412	245,295	558x571x850	27.2	8	\$2,722.93
160427	Clean and Clear Plus Filter 320 sq ft	320/31.6	454	218,040	272,550	327,060	558x571x990	31.8	8	\$2,937.25
160428	Clean and Clear Plus Filter 420 sq ft	420/48.3	568	272,550	340,687	408,825	558x571x1143	34.0	8	\$3,133.06
160429	Clean and Clear Plus Filter 520 sq ft	520/48.3	568	272,550	340,687	408,825	558x571x1270	37.6	4	\$3,328.88

REPLACEMENT CARTRIDGES

						MPG53
Code	Description	Carton Dimensions (mm)	Carton Weight (kg)	Pallet Qty.	Price	
R173572	Replacement Cartridge CNC Plus 240 sq ft	177x177x355	1.4	96	\$291.41	
R173573	Replacement Cartridge CNC Plus 320 sq ft	177x177x355	1.9	96	\$323.79	
R173576	Replacement Cartridge CNC Plus 420 sq ft	177x177x660	2.3	48	\$343.84	
R173578	Replacement Cartridge CNC Plus 520 sq ft	177x177x812	2.8	32	\$360.80	

Integrated continuous High Flow internal air relief is operational only when there is unobstructed flow in the circulating system.

Note: Operating Limits – maximum continual operating pressure of 345kPa / 50psi. Pool/spa (bather) applications, maximum operating water temperature (internal filter) 40°C.

*Terms and conditions apply

Clean & Clear® Plus Filter

High Capacity 'Mega' Cartridge Filter

DIMENSIONS AND PERFORMANCE*

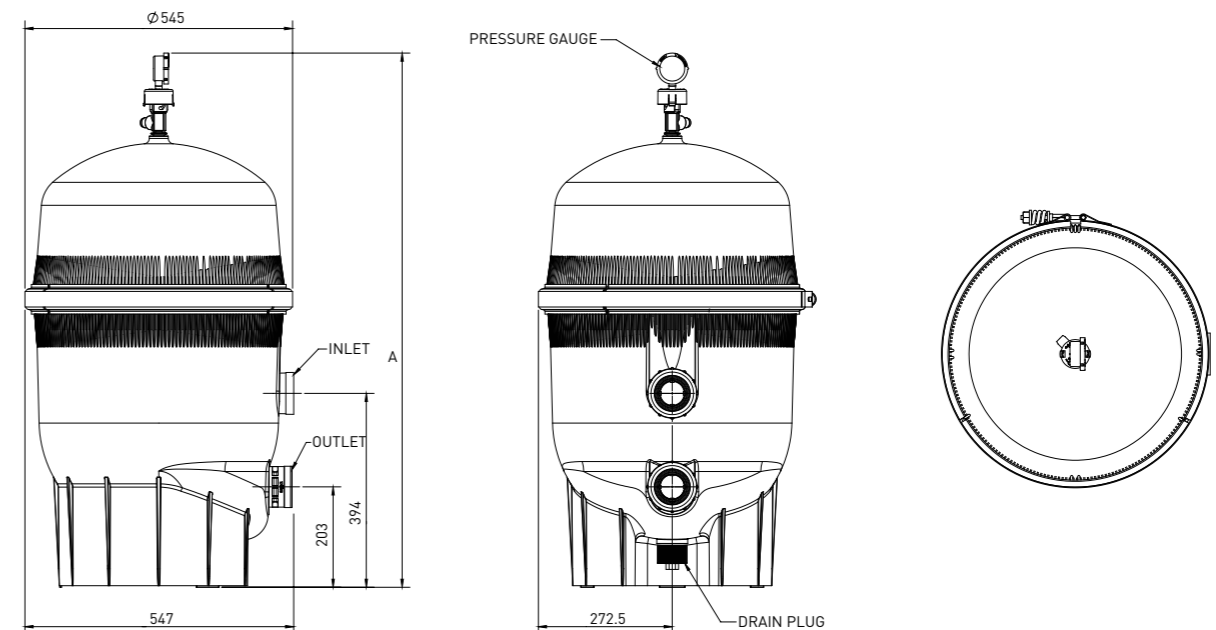
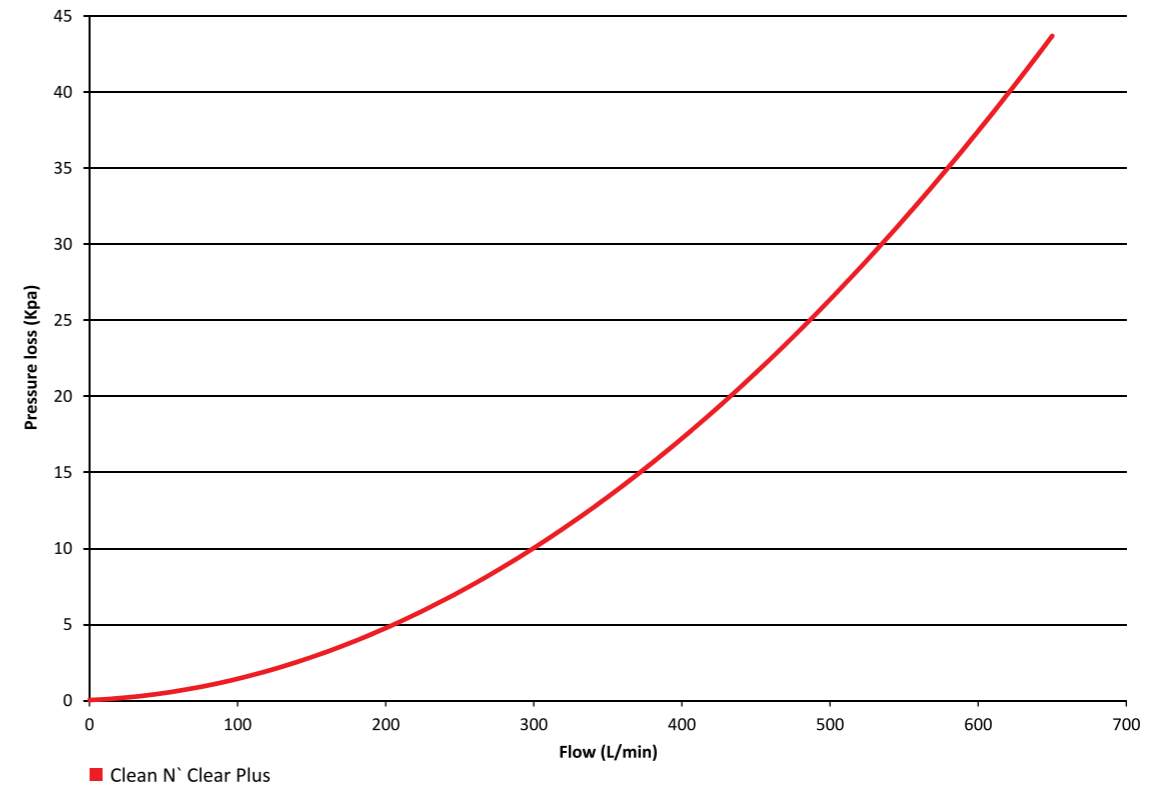

FILTER MODEL	160426	160427	160428	160429
A (MM)	940	1092	1245	1422

*All dimensions in mm.

Posi-Clear RP™ Filter

Raised Port Cartridge Filter



Posi-Clear RP™ Filter

Raised Port Cartridge Filter



FEATURES:

- Raised Port - Uses the whole height of cartridge.
- Raised Port - Cyclone effect flings larger particles out to simply drain away.
- Integrated continuous High Flow™ internal air relief.
- Chemical Resistant Tank Body.
- Lock ring with spring-loaded safety latches.
- Coreless cartridge for easy cleaning.
- 1" Drain and Wash Out.
- Single piece base and body design.
- 50mm / 2" unions included.
- 10 year pro-rata warranty.

The Posi-Clear RP filter is a pool filter which combines a cartridge and centrifugal energy filter into one package. The filter is designed with a raised and offset inlet port which creates a cyclone effect inside the filter that helps to move water through the filter element.

The inside of the filter body is fluted which helps to collect larger particles, which drop to the bottom of the filter tank, reducing the load on the element. This new design is up to 50% more efficient than standard cartridge filter, saving energy and requires less cleaning, saving water.

DIMENSIONS AND PERFORMANCE*

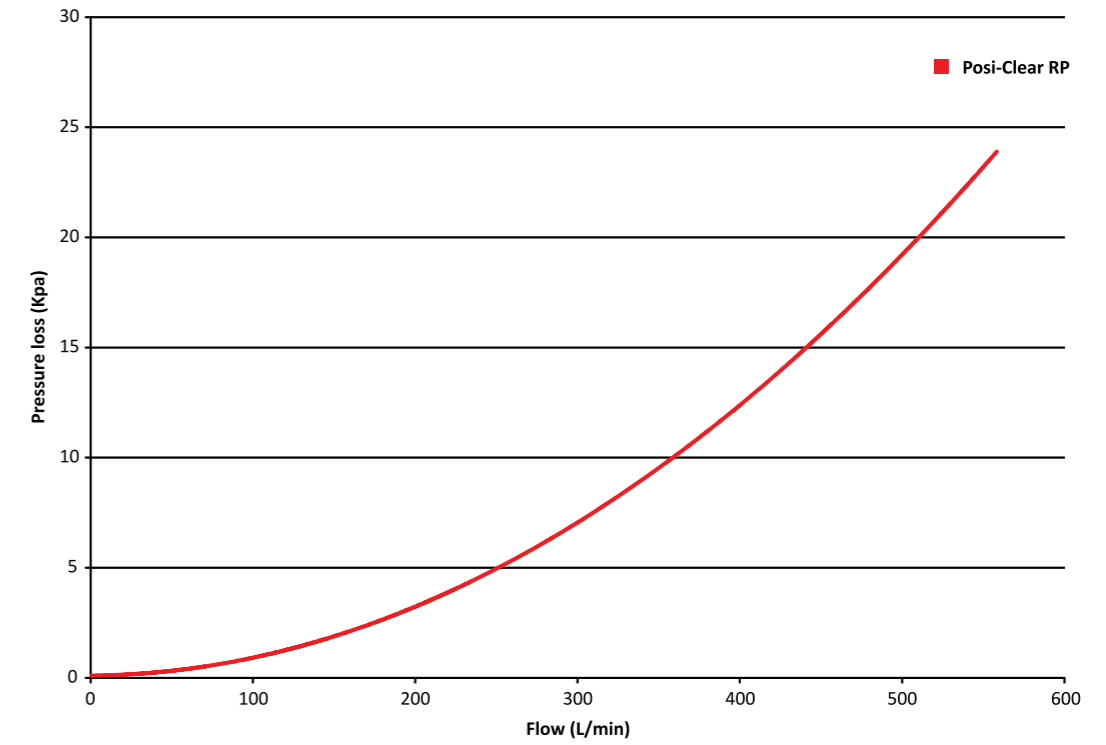

POSI-CLEAR RP FILTERS

Code	Product	Effective Filtration Area (ft ² /m ²)	Max. Flow Rate (LPM)	Turnover Capacity (in Litres)			Carton Dimensions (mm)	Carton Weight (Kg)	Pallet Qty.	Price
				8 Hour	10 Hour	12 Hour				
160351	Posi-Clear RP 100 sq.ft.	100/9.3	380	182,000	228,000	273,000	432x355x850	16.5	27	\$1,383.05
160352	Posi-Clear RP 150 sq.ft.	150/13.9	570	273,000	342,000	410,000	432x355x1040	17.5	18	\$1,581.95
160350	Posi-Clear RP 200 sq.ft.	200/18.6	570	273,000	342,000	410,000	432x355x1040	17.5	18	\$1,722.26

REPLACEMENT CARTRIDGES

Code	Description	Price
R173215	Replacement Cartridge Posi-Clear RP 100 sq ft	\$382.38
R173216	Replacement Cartridge Posi-Clear RP 150 sq ft	\$477.98
R173217	Replacement Cartridge Posi-Clear RP 200 sq ft	\$578.20

Note: Operating Limits – maximum continual operating pressure of 345kPa. Pool/spa (bather) applications, maximum operating water temperature (internal filter) 40°C.

*Terms and conditions apply

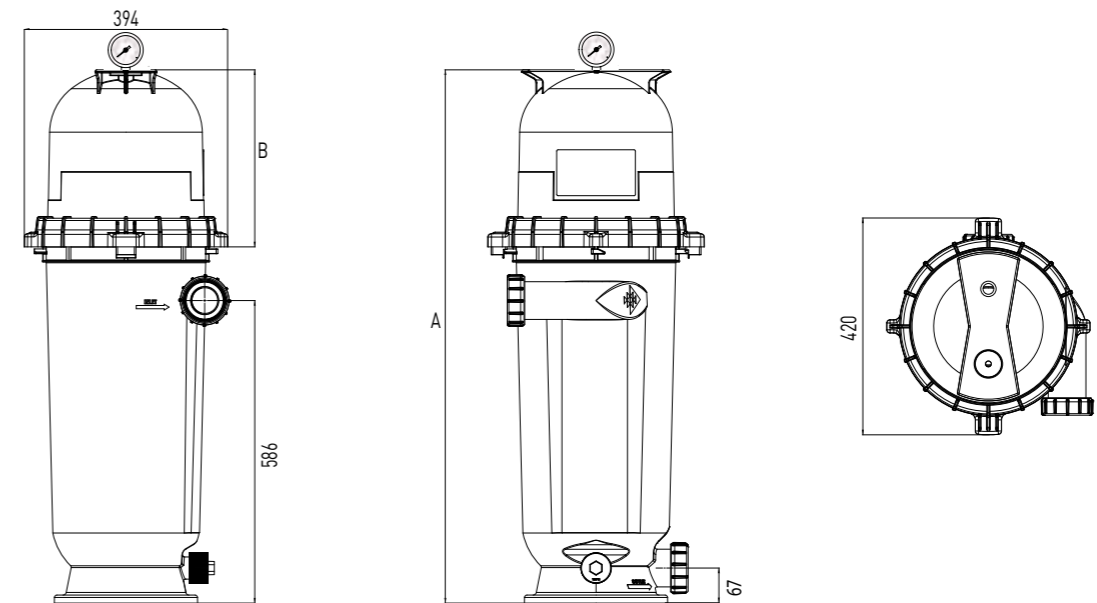

Filter Model	160351	160352	160350
A (mm)	838	1029	1029
B (mm)	152	343	343
Clearance Required	1549	1930	1930

*All dimensions in mm.

FreeFlo Cartridge Filter

High Performance Cartridge Filter



FEATURES:

- Built from highly durable UV resistant plastics.
- Lid and locking ring have large handles for easy grip.
- 2 inlet ports and 2 outlet ports, 90 degrees opposed allows fitting to any plumbing configuration.
- 40mm and 50mm barrel unions included.
- Small footprint.
- Stainless steel, oil-filled, pressure gauge.
- Internal bypass valve prevents exceedingly high pressures.
- 5 year limited warranty*.

The FreeFlo Cartridge filter combines top-end filter performance with with low maintenance. This dependable design uses special filter elements to strip tiny particles from your pool water...particles as small as 8 microns. (An average grain of beach sand is 1,000 microns!) Plus, cleaning is a breeze.

Open the top, remove the cartridge, hose it off and the FreeFlo filter is ready to go again.



FREEFLO FILTERS

MPG53

Code	Product	Effective Filtration Area (ft ² /m ²)	Max Flow Rate (LPM)	Carton Dimensions (mm)	Carton Weight (Kg)	Pallet Qty.	Price
FFCF-075	FreeFlo Cartridge Filter 75 sq ft	75 / 7	280	320x320x900	10.2	12	\$872.69
FFCF-100	FreeFlo Cartridge Filter 100 sq ft	100 / 9.3	380	320x320x900	11.8	9	\$1,046.92
FFCF-150	FreeFlo Cartridge Filter 150 sq ft	150 / 13.9	550	320x320x1100	13.4	9	\$1,134.81
FFCF-200	FreeFlo Cartridge Filter 200 sq ft	200/18.6	680	320x320x1300	15.7	9	\$1,224.24

FREEFLO REPLACEMENT CARTRIDGES

MPG53

Code	Description	Carton Dimensions (mm)	Carton Weight (kg)	Pallet Qty.	Price
800750	Replacement Cartridge FFCF 75 sq ft	315x315x860	3.2	1	\$334.58
800760	Replacement Cartridge FFCF 100 sq ft	315x315x860	4.8	1	\$394.72
800761	Replacement Cartridge FFCF 150 sq ft	315x315x1040	6.4	1	\$514.98
800762	Replacement Cartridge FFCF 200 sq ft	315x315x1220	7.7	2	\$618.29

Note: Operating Limits – maximum continual operating pressure of 250kPa. Pool/spa (bather) applications, maximum operating water temperature (internal filter) 45°C.

*Terms and conditions apply

FreeFlo Cartridge Filter

High Performance Cartridge Filter

DIMENSIONS AND PERFORMANCE*

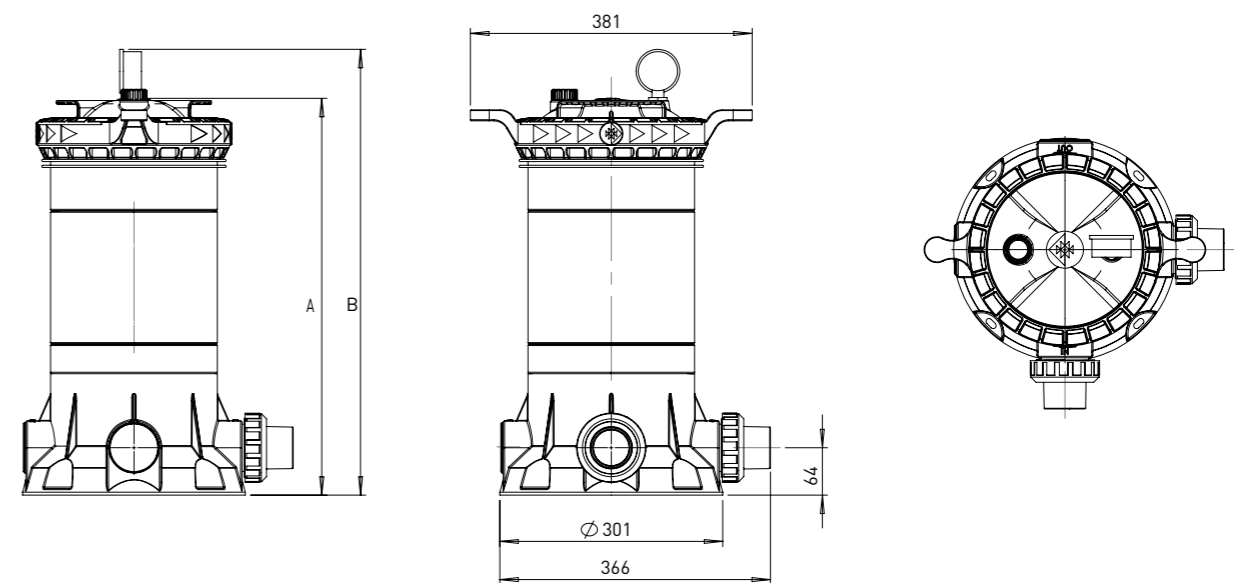
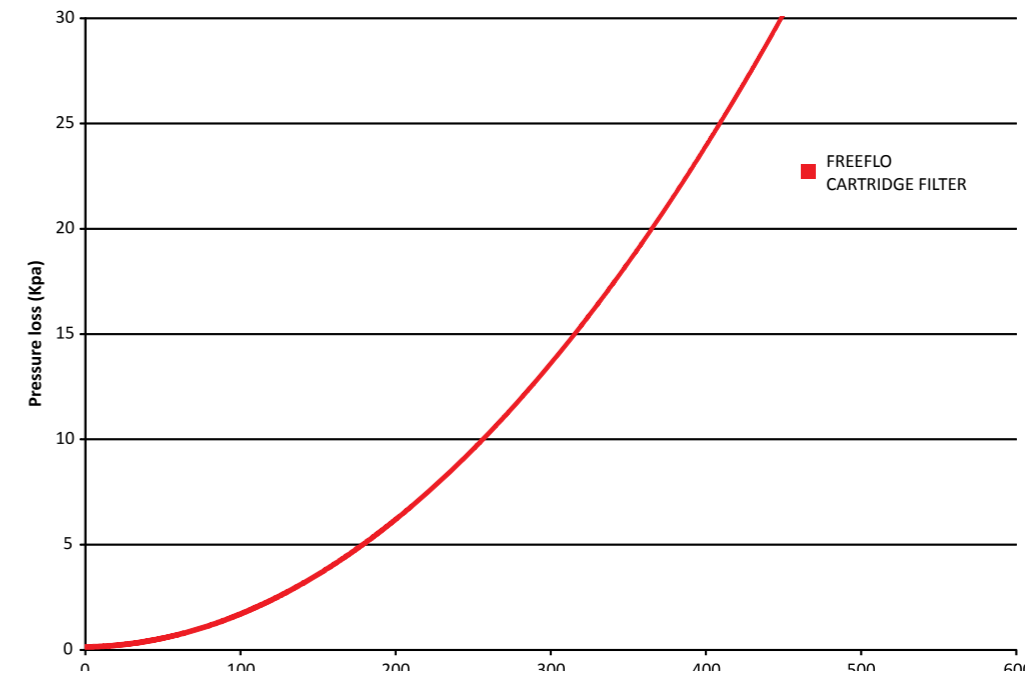

Filter Model	FFCF-075	FFCF-100	FFCF-150	FFCF-200
A (mm)	715	715	895	1075
B (mm)	782	782	962	1142

*All dimensions in mm.

Tagelus® Sand Filter

Fibreglass Tank Sand Filter Top Mount MPV



Tagelus® Sand Filter

Fibreglass Tank Sand Filter Top Mount MPV



FEATURES:

- Special lateral design provides superior flow characteristics and long filter cycles for economical operation.
- Maximum Operating Pressure 345kPa / 50psi.
- Combination water and sand drain makes servicing and winterizing fast and easy.
- 50 and 60D models standard with plastic clamp.
- 10 year pro-rata warranty.*

Our process creates a one-piece, fibreglass reinforced tank with superior strength and durability. Tagelus® filters are equipped with a six-position, clamp style, top-mounted multi port valve and barrel unions.

DIMENSIONS AND PERFORMANCE*

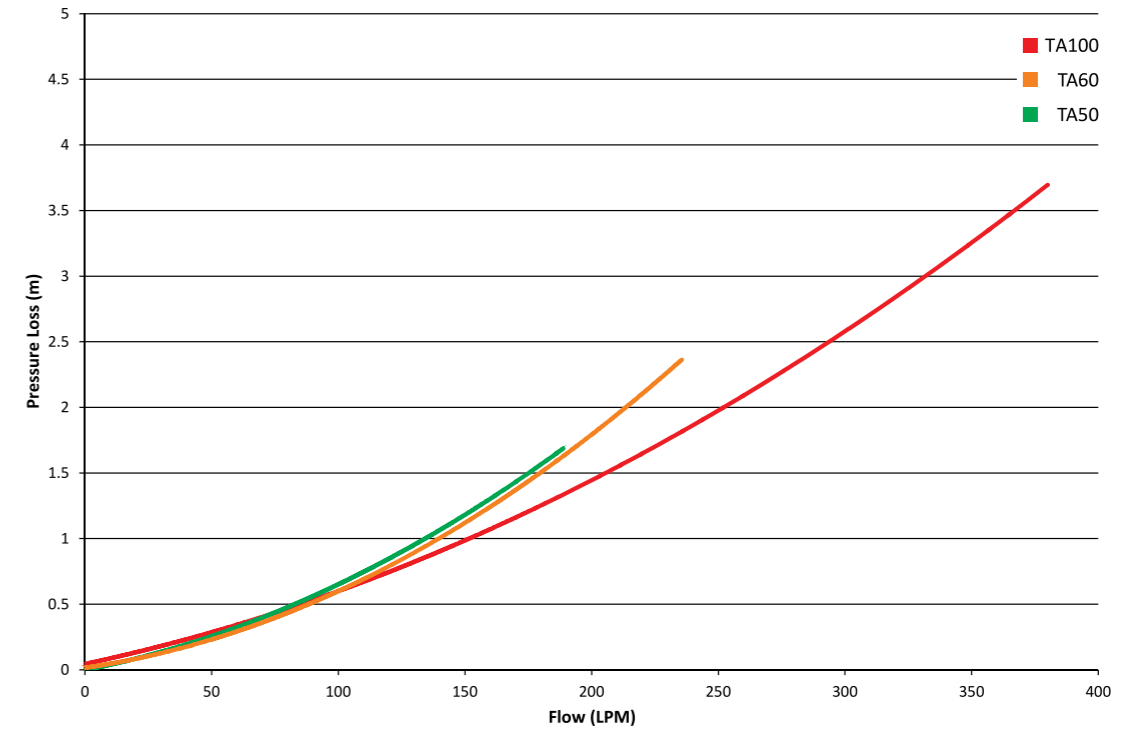

TAGELUS FILTERS

Code	Product	Effective Filtration Area (ft ² /m ²)	Min Flow Rate ¹ (LPM)	Max Flow Rate (LPM)	Turnover Capacity (in Litres)			Carton Dimensions (mm)	Carton Weight (kg)	Pallet Qty.	Price
					8 Hour	10 Hour	12 Hour				
140216	TA50D Tagelus Sand Filter 21"	2.3 / 0.2	130	190	90,850	113,562	136,275	558x558x990	14.4	8	\$1,913.45
140217	TA60D Tagelus Sand Filter 24"	3.1 / 0.3	170	228	109,440	136,275	163,520	635x635x1041	15.4	8	\$2,100.01
145284	TA60D Tagelus Sand Filter 24" with 2" MPV	3.1 / 0.3	170	250	120,000	150,000	180,000	635x635x1041	17.3	8	\$2,180.19
140218	TA100D Tagelus Sand Filter 30"	4.9 / 0.5	280	379	181,699	227,125	272,550	787x787x1193	31.3	2	\$3,222.49

¹ Minimum flow rate required to effectively backwash filter.

ACCESSORIES FOR TAGELUS FILTERS

Code	Description	Carton Dimensions (mm)	Carton Weight (kg)	Pallet Qty.	Price
262506	1.5" MPV for TA50D and TA60D Filters	228x406x215	2.7	125	\$693.29
261185	2.0" MPV for TA100D Filter	228x228x368	3.8	125	\$817.72

Note: Operating Limits – maximum continual operating pressure of 345kPa/50psi.
Pool/spa (bather) applications, maximum operating water temperature (internal filter) 40°C.

*Terms and conditions apply

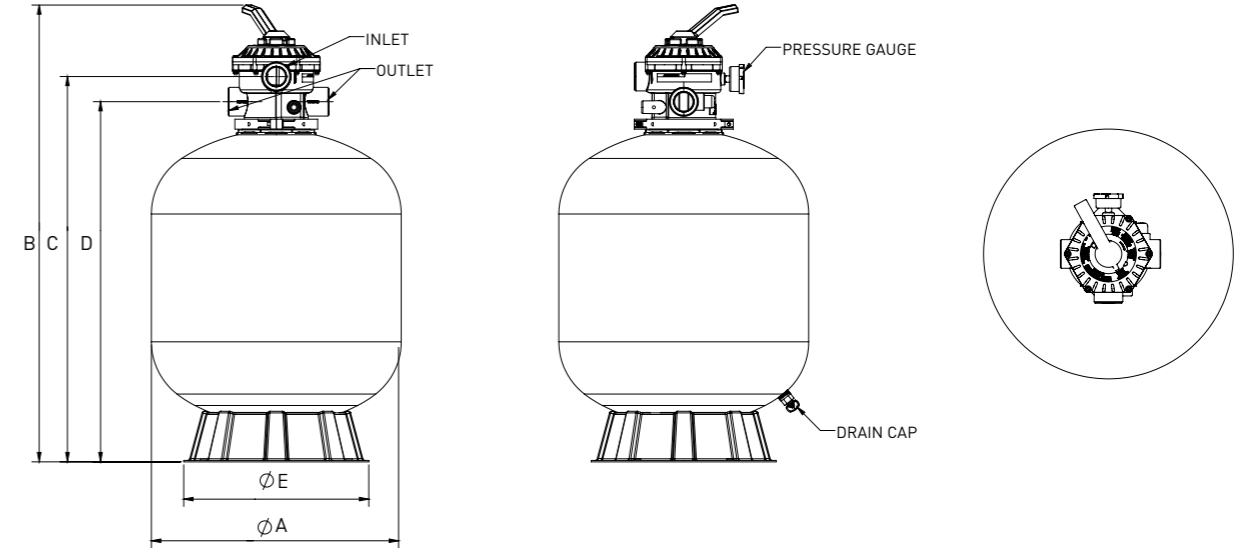

Model	DIMENSIONS (mm)				
	A	B	C	D	E
TA 50D	546	1003	848	819	400
TA 60D	622	1080	925	896	400
TA 100D	775	1200	1068	987	610

Model	Sand	FILTER MEDIA (kg)	
		Glass	
		Fine	Coarse
TA 50D	102	60	30
TA 60D	148	90	45
TA 100D	273	150	90

* Please see filter media pricing on page 36.

*All dimensions in mm.

Leisuretime® II Sand Filter

Fibreglass Tank Sand Filter Top Mount MPV



Leisuretime® II Sand Filter

Fibreglass Tank Sand Filter Top Mount MPV



FEATURES:

- Spun-woven, UV resistant fibreglass construction for exceptional strength, chemical resistance and long life.
- Six-function multi-port valve for easy control of all filter functions • Filter • Waste • Backwash • Closed • Rinse • Recirculate.
- Stainless Steel clamp for corrosion resistance and allows 360 degree rotation of multi-port valve to simplify installation.
- Includes MPV and barrel unions.
- New 40mm MPV with screw down lid.
- 10 year pro-rata warranty.*

The Leisuretime® II Fibreglass Sand Filter is the perfect high performance sand filter. It's incredibly simple to operate and maintain, and it's built with long-term reliability in mind. Plus, its highly efficient design provides all the clean, crystal clear water your pool requires year after year.

DIMENSIONS AND PERFORMANCE*

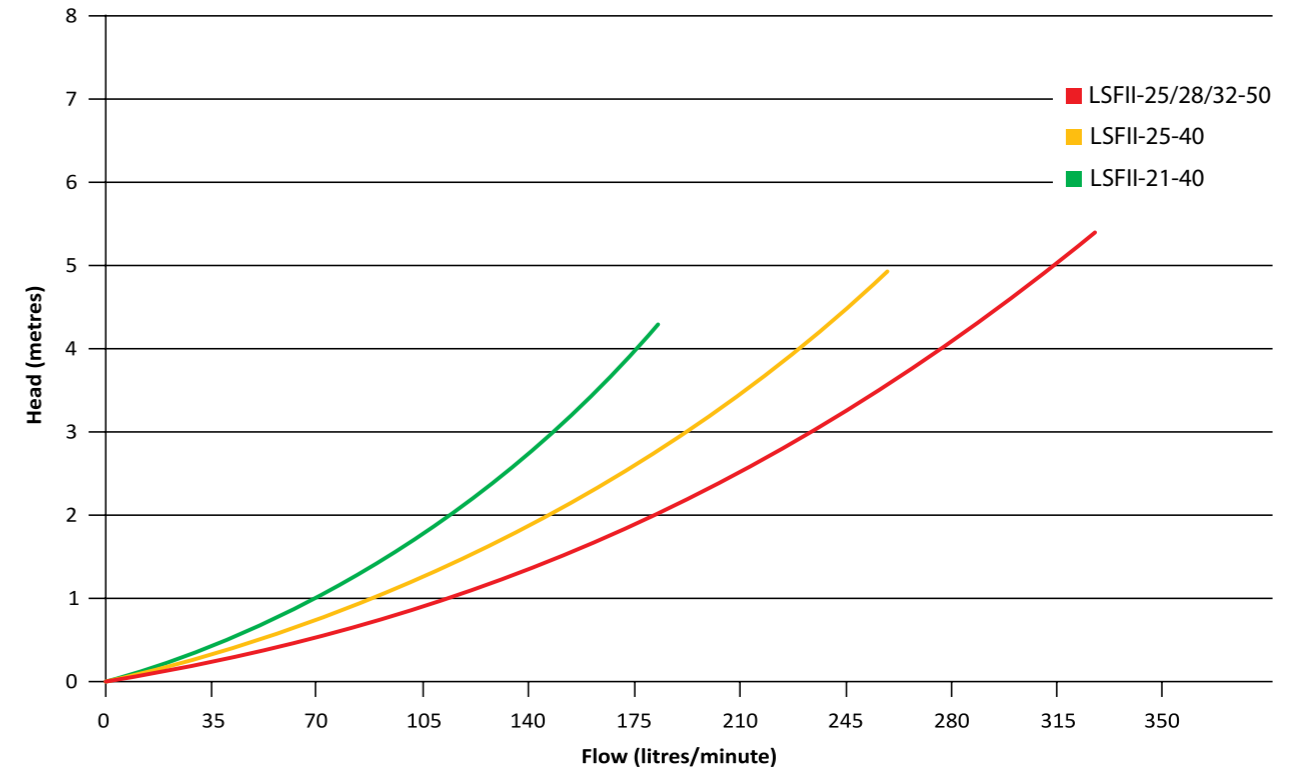

LEISURETIME II SAND FILTERS

MPG53

Code	Product	Effective Filtration Area (ft ² /m ²)	Min Flow Rate ¹ (LPM)	Max Flow Rate (LPM)	Turnover Capacity (in Litres)			Carton Dimensions (mm)	Carton Weight (kg)	Pallet Qty.	Price
					8 Hour	10 Hour	12 Hour				
LSFII-21-40	Leisuretime II 21" Sand Filter 40mm MPV	2.1 / 0.2	120	190	91,200	114,000	136,800	540x540x890	16	8	\$1,033.05
LSFII-25-40	Leisuretime II 25" Sand Filter 40mm MPV	3.2 / 0.3	180	260	124,800	156,000	187,200	620x620x980	21.5	8	\$1,239.66
LSFII-25-50	Leisuretime II 25" Sand Filter 50mm MPV	3.2 / 0.3	180	280	134,400	168,000	201,600	730x730x830 + 290x290x400	23	8	\$1,332.17
LSFII-28-50	Leisuretime II 28" Sand Filter 50mm MPV	4.1 / 0.41	230	345	165,600	207,000	248,400	730x730x830 + 290x290x400	27	2	\$1,654.42
LSFII-32-50	Leisuretime II 32" Sand Filter 50mm MPV	5.4 / 0.5	270	415	199,200	249,000	298,800	800x800x900 + 290x290x400	31	2	\$3,106.85

¹ Minimum flow rate required to effectively backwash filter.

Note: Operating Limits – maximum continual Operating pressure of 250kPa. Maximum operating water temperature (internal filter) 43°C

*Terms and conditions apply

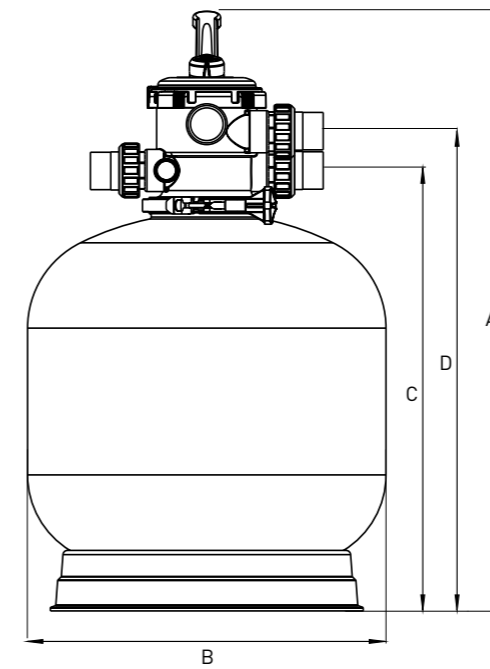

DIMENSION				
Model	A	B	C	D
LSFII-21-40	875mm	535mm	670mm	730mm
LSFII-25-40	980mm	635mm	775mm	835mm
LSFII-25-50	985mm	635mm	780mm	840mm
LSFII-28-50	1050mm	723mm	877mm	960mm
LSFII-32-50	1200mm	800mm	1002mm	1085mm

FILTER MEDIA (kg)				
Model	Sand	Zeolite	Glass	
			Fine	Coarse
LSFII-21-40	90	70	60	30
LSFII-25-40	140	105	90	45
LSFII-25-50	140	105	90	45
LSFII-28-50	185	140	120	60
LSFII-32-50	220	165	135	75

* Please see filter media pricing on page 36.

*All dimensions in mm.

MasterTemp® Heater

High Performance & Efficient Gas Heaters



FEATURES:

- Heats up fast so no long waits before enjoying your pool or spa.
- Best-in-class energy efficiency.*
- Manual gas shut-off when service is required.
- Eco-friendly MasterTemp® Heater is certified for low NOx emission and outperforms industry standards.
- Rotating digital display allows for easy viewing.
- Tough, rustproof exterior handles the heat and weathers the elements.
- 2 year limited warranty.*

MasterTemp® heaters offer all the efficiency, convenience and reliability features you want in a pool heater, plus a lot more. As easy to use as your home heating system, plus, user-friendly indicator lights make system operation and monitoring a snap.

The compact design and super-quiet operation won't intrude on your poolside leisure time. Heavy-duty (HD) unit with cupro-nickel exchanger stands up to the harshest of applications, like low pH, high flow or heavy use.

MasterTemp® Heater

High Performance & Efficient Gas Heaters

DIMENSIONS AND PERFORMANCE*

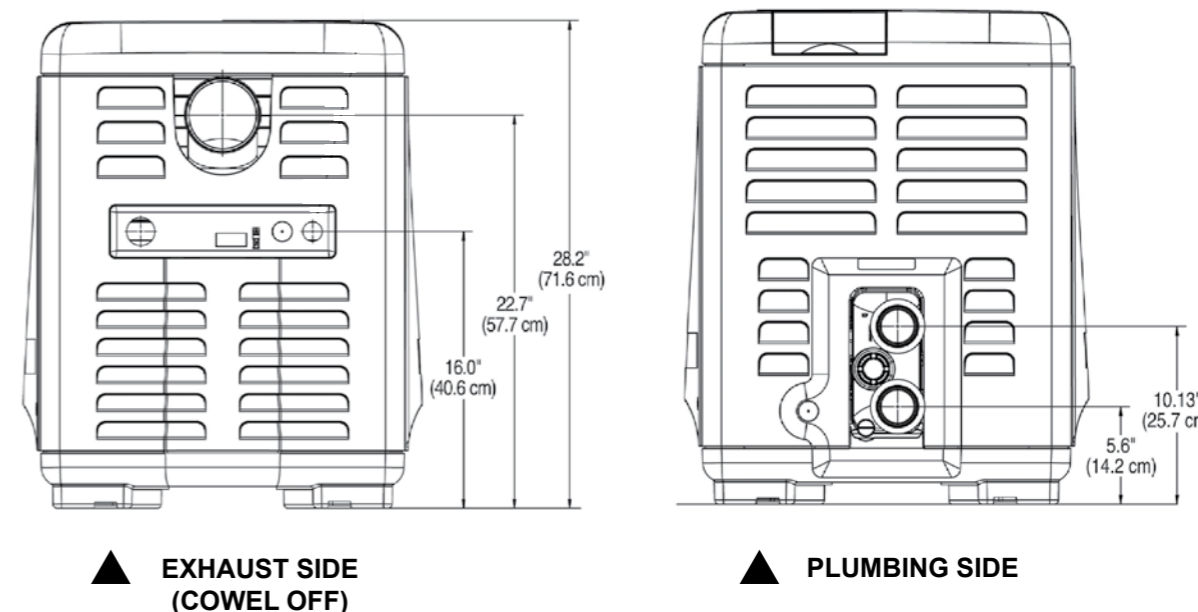
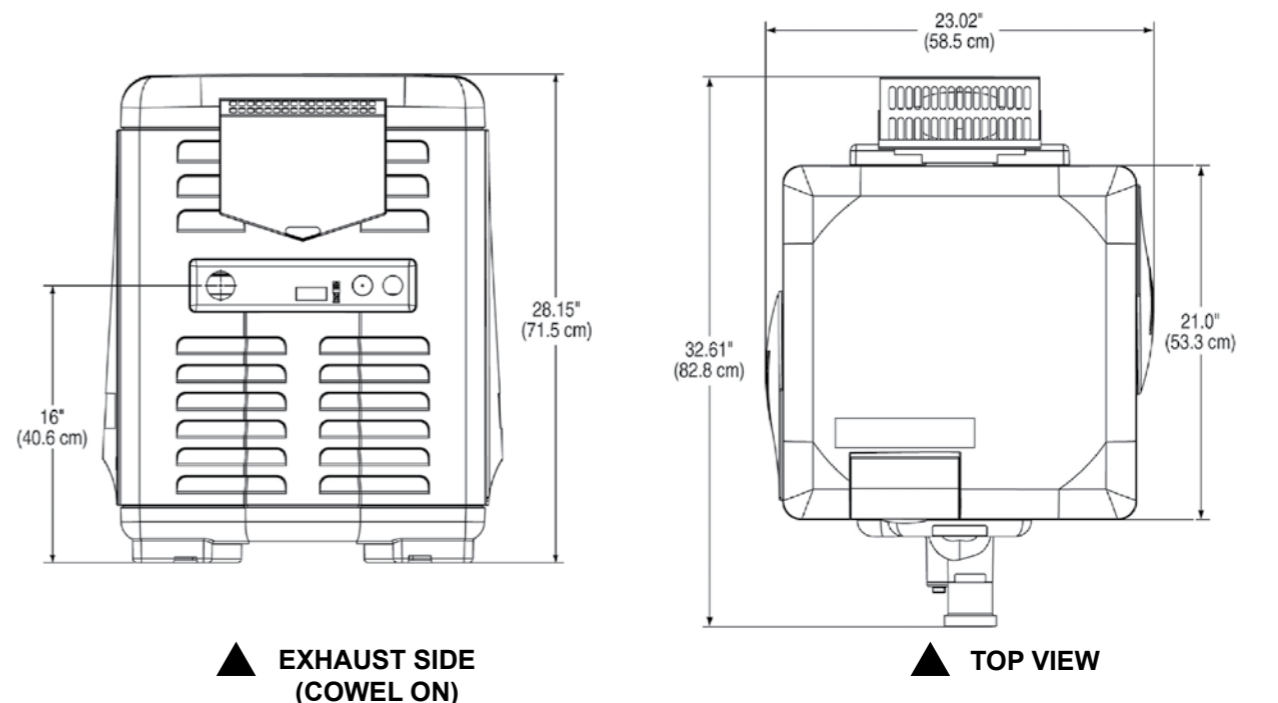

MASTERTEMP HEATERS

MPG27

Code	Product	Gas Type	BTU (000's)	Carton Dim. (mm)	Carton Weight (kgs)	Pallet Qty.	Price
460946	MasterTemp Heavy Duty 200HD	Natural	200	673x889x762	58	4	\$11,374.64
460945	MasterTemp Heavy Duty 300HD	Natural	300	673x889x762	61.7	4	\$12,595.17
460944	MasterTemp Heavy Duty 400HD	Natural	400	673x889x762	63.5	4	\$13,449.84
460949	MasterTemp Heavy Duty 200HD	Propane / LPG	200	673x889x762	58	4	\$11,374.64
460948	MasterTemp Heavy Duty 300HD	Propane / LPG	300	673x889x762	61.7	4	\$12,595.17
460947	MasterTemp Heavy Duty 400HD	Propane / LPG	400	673x889x762	63.5	4	\$13,449.84
ACCESSORIES							
SF43-11-06	6" Flue Adaptor						\$346.37
SF43-11-08	8" Flue Adaptor						\$362.86
461031	Direct Air Intake Kit MT200, 300 & 400						\$764.71
801954	Flow Switch 50mm Spigot (requires 2 x 50mm F-F PVC couplings)						\$409.34
802010	External Inlet High Limit Switch Kit 50mm						\$385.35

Note: The MasterTemp® Heater is certified for low NOx emissions. *Heavy Duty (HD) Cupro-Nickel Heat Exchanger 82% Efficient.
*Terms and conditions apply

*All dimensions in mm.

MasterTemp® 125

High Performance Spa Heater



MasterTemp® 125

High Performance Spa Heater



FEATURES:

- High-performance, affordable heater with premium features.
- Energy efficiency among the highest in its class.
- 40mm (1-1/2") plumbing connections - ideal for small bodies of water including above ground pools and spas.
- Pre-mixed combustion technology for fast heat up and low NOx emissions.
- Easy to use digital display/control.
- Lightweight, easy to handle and ship.

The MasterTemp 125 Heater provides energy-savings and advanced operating features that were only available from much larger heaters. With its revolutionary premixed gas combustion technology, the MasterTemp 125 Heater offers high thermal efficiency, among the best in its class. The advanced digital display/controller provides more information and better control. The MasterTemp 125 heater is also compact and lightweight, making it easy to handle and ship.

DIMENSIONS AND PERFORMANCE*

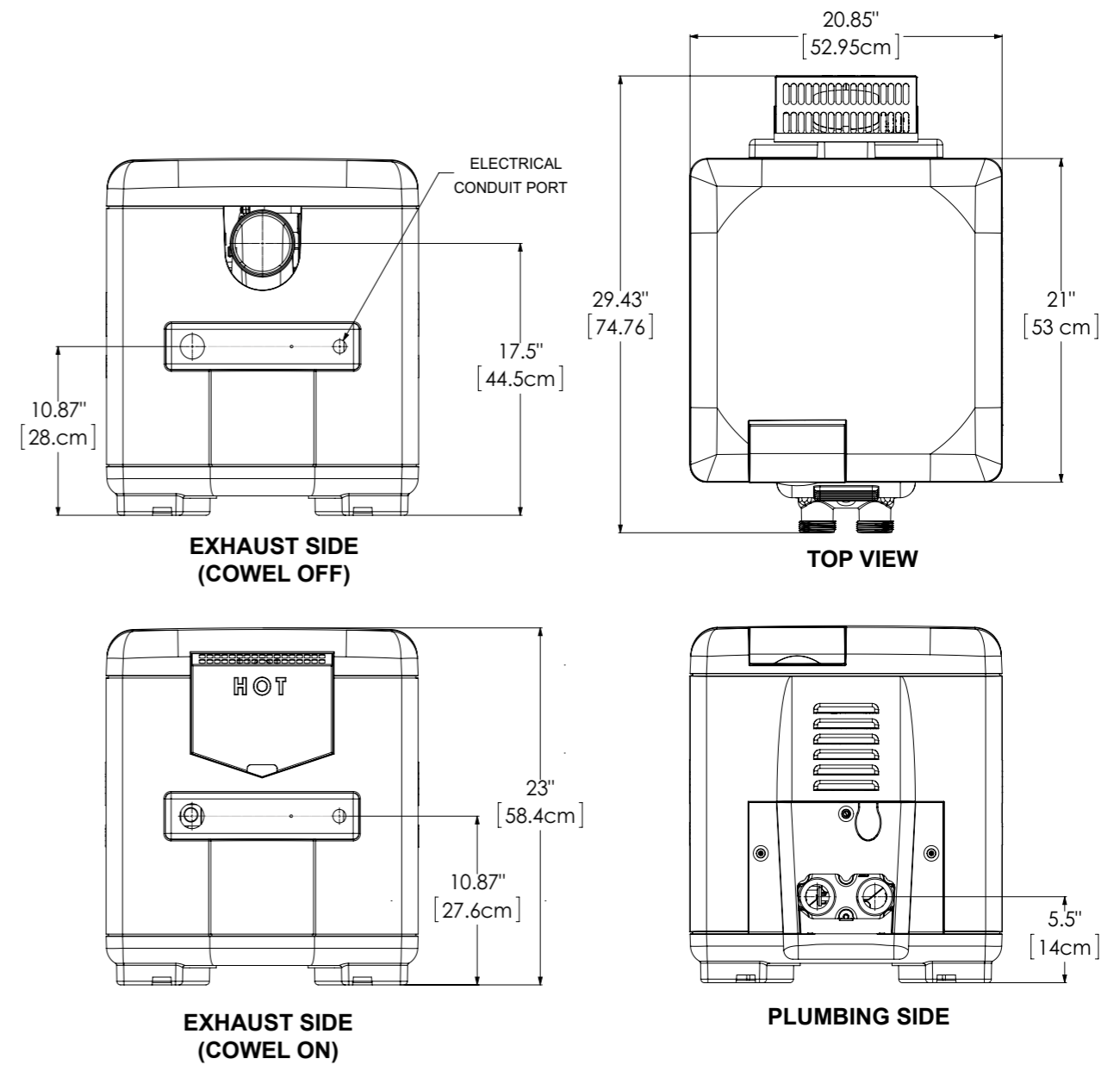

MASTERTEMP HEATERS

							MPG27
Code	Product	Gas Type	BTU (000's)	Carton Dim. (mm)	Carton Weight (kgs)	Pallet Qty.	Price
461092	MasterTemp 125	Natural	125	930x570x625	45	4	\$7,087.78
461093	MasterTemp 125	Propane	125	930x570x625	45	4	\$7,087.78
ACCESSORIES							
SF43-11-06	6" Flue Adaptor						\$346.37
SF43-11-08	8" Flue Adaptor						\$362.86
474845	Direct Air Intake Kit						\$706.23
801953	Flow Switch 40mm						\$385.35
802011	External Inlet High Limit Switch Kit						\$385.35

Note: The MasterTemp® Heater is certified for low NOx emissions. *Heavy Duty (HD) Cupro-Nickel Heat Exchanger 82% Efficient.
 *Terms and conditions apply

*All dimensions in mm.



FEATURES:

- High-performance, affordable heat pump with premium features
- Energy efficiency among the highest in its class with COP ratings far in excess of standard heat pumps
- Titanium threaded heat exchanger
- Intuitive LCD touch screen
- Heats, cools and offers auto defrost
- Corrosion protection Hydrophilic Evaporator Coating
- Filter dryer eliminates ice and dirt block and also attenuates noise for quiet operation
- 15 years warranty*

The swimming pool heat pump is one of the most economical ways of heating your swimming pool efficiently. Using the free renewable energy from the air, it is up to 14 times more efficient than traditional heating. The swimming pool heat pump extends your swimming season and gives you comfort at high level. You could enjoy swimming not only in summer, but also in spring, autumn and even winter time.

DIMENSIONS AND PERFORMANCE*

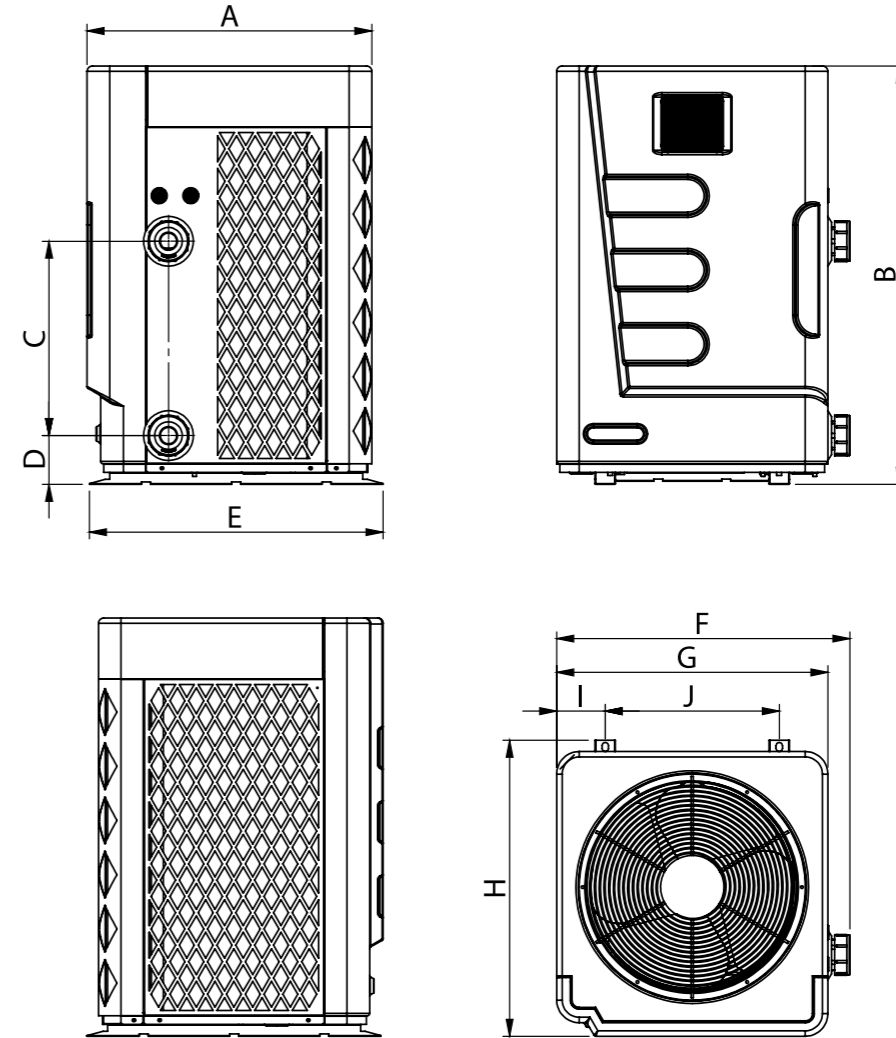

ULTRATEMP VXi HEAT PUMPS

MPG27

Code	Product	Capacity @27C Air (kW)	COP	Min Flow (LPM)	Power Input (kW)	Voltage	Current (A)	Carton Dim. (mm)	Carton Weight (kgs)	Pallet Qty.	Price
UTHP-17-VXi	ULTRATEMP VXi 17KW	13.5	6.5 - 13.5	108	2.13	230-240V	11.3	670 x 655 x 926	90	1	\$10,936.33
UTHP-24-VXi	ULTRATEMP VXi 24	17.5	6.4 - 13.8	133	2.78	230-240V	13.3	670 x 655 x 926	98	1	\$15,442.72
UTHP-28-VXi	ULTRATEMP VXi 28KW	20.6	6.5 - 13.6	158	3.29	230-240V	21.1	763 x 745 x 1090	137	1	\$18,029.18
UTHP-32-VXi	ULTRATEMP VXi 32KW 3P	24	6.8 - 14.2	166	3.65	230-240V	22.8	763 x 745 x 1090	140	1	\$19,766.78
ACCESSORIES											MPG48
803247	Control Pad Extension Kit										\$82.48

*As per the 43South Warranty Schedule - 15 years warranty on the titanium heat exchanger and cabinet. 5 years warranty on the compressor. 3 years warranty on the refrigeration circuit and parts.

	UTHP-13-VXi, UTHP-17-VXi	UTHP-20-VXi, UTHP-24-VXi	UTHP-20-VXi, UTHP-24-VXi, UTHP-28-VXi
A	630	720	781
B	925.5	1090	1263
C	430	466	600
D	107.7	97.4	97.4
E	650	740	820
F	649	739	801
G	600	690	752
H	655	745	786
I	107.5	110	108.5
J	385	470	535

*All dimensions in mm.

UltraTemp® HXi

Inverter Heat Pump



UltraTemp® HXi

Inverter Heat Pump



- FEATURES:**
- Full inverter heat pump with variable speed compressor and fan motor.
 - Wi-fi module included, compatible with app freely available on app store.
 - Silent running mode, for neighbourhood peace and quiet.
 - Energy efficiency among the highest in its class with COP ratings far in excess of standard heat pumps.
 - Titanium threaded heat exchanger.
 - Intuitive colour LCD touch screen.
 - Heats, cools and offers auto defrost.
 - 15 years warranty*

The Pentair UltraTemp® HXi heat pump automatically heats or cools your pool according to the desired temperature. It adapts to outdoor conditions to ensure optimum bathing comfort while minimising energy consumption. Equipped with full-inverter technology, the new Pentair UltraTemp® HXi heat pump delivers powerful, yet quiet, performance, thanks to the combination of a variable speed compressor and fan motor. They adjust their speed automatically following the operating mode selected by the user via the colour touchscreen or optional app.

DIMENSIONS

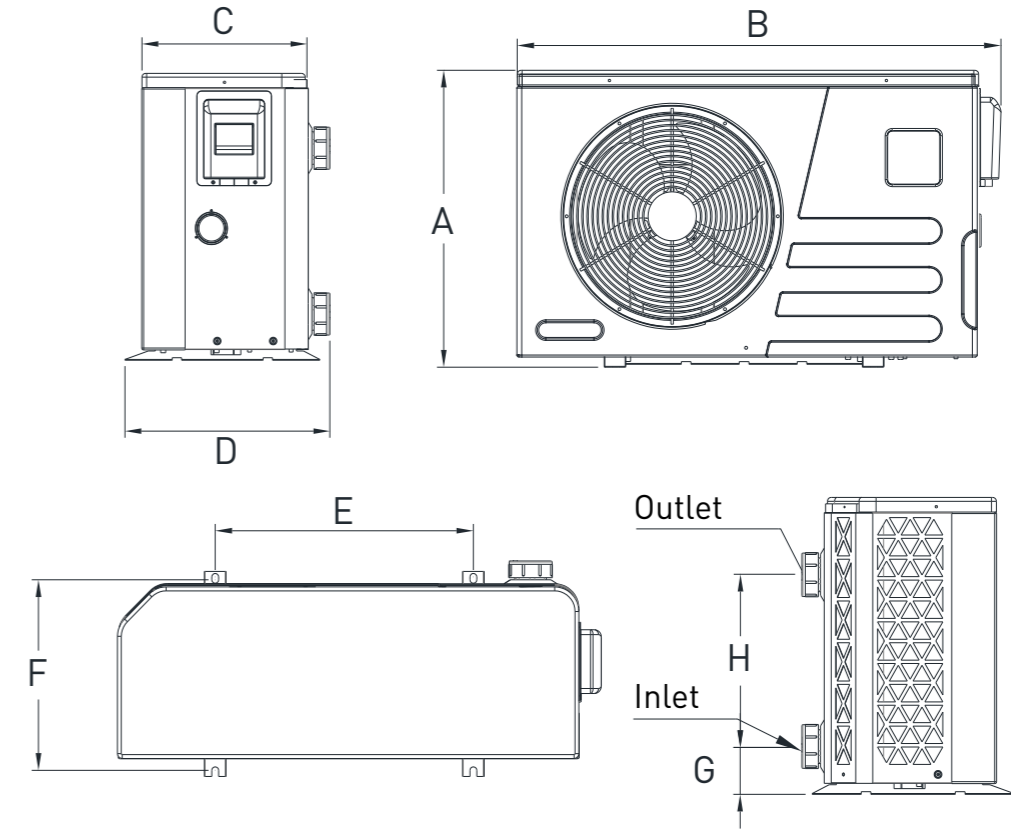

Figure 1: Dimensions

ULTRATEMP HXi HEAT PUMPS

MPG27

Code	Product	Capacity kW (@27°C Air)	COP	Power Input (kW)	Voltage	Current (A)	Compressor Type	Water Flow (LPM)	Sound Level (dBA)	Price
UTHP-9-HXi	UltraTemp HXi 9kW	2.3~9.0	14.2~6.4	0.16~1.41	230-240V / 50Hz	8.4	Rotary Inverter	53	39-50	\$6,211.70
UTHP-12-HXi	UltraTemp HXi 12kW	2.5~12.0	14.1~6.3	0.18~1.90	230-240V / 50Hz	10.9	Rotary Inverter	66	41-52	\$7,352.39
UTHP-16-HXi	UltraTemp HXi 16kW	3.1~16.0	13.9~6.3	0.22~2.54	230-240V / 50Hz	16.6	Rotary Inverter	86	42-53	\$9,303.24
UTHP-20-HXi	UltraTemp HXi 20kW	3.70~20.0	13.8~6.2	0.27~3.08	230-240V / 50Hz	17.5	Rotary Inverter	100	43-54	\$11,705.11
UTHP-24-HXi	UltraTemp HXi 24kW	6.5~24.3	14.5~6.5	0.45~3.74	230-240V / 50Hz	22	Rotary Inverter	141	44~55	\$14,006.76
UTHP-28-HXi	UltraTemp HXi 28kW	7.1~28.2	14.3~6.4	0.49~4.41	400-415V / 3P	11	Rotary Inverter	158	45~56	\$16,462.33

*As per the 43South Warranty Schedule - 15 years warranty on the titanium heat exchanger and cabinet. 5 years warranty on the compressor. 3 years warranty on the refrigeration circuit and parts.

Key	UTHP-9-HXi, UTHP-12-HXi	UTHP-16-HXi	UTHP-20-HXi, UTHP-24-HXi, UTHP-28-HXi
A	625mm	775mm	855mm
B	1015mm	1025mm	1159mm
C	350mm	385mm	428mm
D	425mm	475mm	520mm
E	535mm	615mm	790mm
F	385mm	430mm	467mm
G	95mm	95mm	100mm
H	350mm	350mm	465mm

*All dimensions in mm.

Prowler® 920

Robotic Inground Pool Cleaner



FEATURES:

- All-surface deep cleaning with a powerful, high-speed scrubbing brush.
- Fast and easy debris removal with a top access filtration basket.
- Select from a large or fine debris filtration cartridges.
- Programmable daily cleaning schedules with a built-in weekly timer.

Pool walls and floor get deep-scrubbing and powerful vacuuming action, all the way up to the tile line. Prowler 920 comes with separate mesh baskets made for either large or fine debris, to customize the filtration level or do lightning-fast swap out for touch ups.

SPECIAL FEATURES

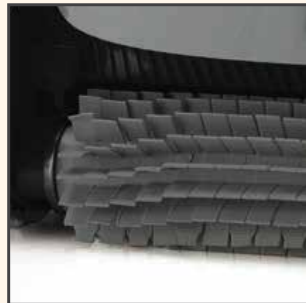

All-surface deep cleaning.



Fast and Easy Debris Removal.



Select from Larger or Fine Debris Filtration Cartridges.



Programmable Daily Cleaning Schedules.

PROWLER 920

MPG21

Code	Product	Carton Dimensions (mm)	Carton Weight (kg's)	Pallet Qty.	Price
360322-AU	Prowler 920 Robotic Inground Pool Cleaner	575x315x230	13.2	12	\$3,492.46
ACCESSORIES					
360141	Caddy Cart For Prowler Robotic Cleaner				\$460.97

*Terms and conditions apply



Racer® LS

Pressure-Side Inground Pool Cleaner



FEATURES:

- 30% faster cleaning for maximum efficiency.
- Nearly 1/3 more cleaning power and 40% larger intake than other pressure-side cleaners - leaves no debris behind.
- Front rotating brush scrubs and scours for a deep and detailed clean.
- Wide tyre's for steady traction.
- Cleans continuously in forward and revers direction for complete uninterrupted coverage.
- Ultra-bright LED lights illuminate and enhance night time cleaning.
- 2 year limited warranty.*

Pentair Racer LS has 25% more cleaning power than other pressure side inground pool cleaners. It is built for superior vacuum performance that provides maximum debris removal. Quad jet vacuum technology gives you more cleaning power for a brighter, cleaner pool.

RACER LS CLEANER

MPG36

Code	Product	Carton Dimensions (mm)	Carton Weight (kg's)	Pallet Qty.	Price
360330	Racer LS Pressure-Side In-ground Pool Cleaner	584x584x279	10.2	16	\$2,126.25

*Terms and conditions apply

Rebel® 2

Automatic Vacuum Pool Cleaner



FEATURES:

- Ideal for All Pool Types
- Easy Installation
- Clog-Free Cleaning
- More Cleaning Power
- Maneuvers Up and Over Obstacles
- More Thorough Cleaning Coverage
- 3 year limited warranty.*

The Rebel® 2 cleaner's programmed steering and compact, two-wheeled design maneuvers from deep to shallow bottoms, up 90 degree floor-to-wall angles all the way to the water line, and into tight spaces that other cleaners miss.

A Sure-Flow Turbine passes dirt and debris, reducing the clogging that is common with other two-wheel cleaners. Installation is a snap – just set it and forget it.

SPECIAL FEATURES



CLOG-FREE CLEANING

Sure-Flow turbine design captures debris, large and small.



MANEUVERS UP & OVER OBSTACLES

Dual-action roller skirt and upgraded chassis design provide uninterrupted cleaning.



MORE CLEANING POWER

Enhanced hydraulic design perfectly complements variable speed and flow pumps.



MORE THOROUGH CLEANING COVERAGE

SmartTrac™ programmed steering and Steady-grip tyre traction for superior floor-to-wall cleaning.

REBEL 2

MPG36

Code	Product	Carton Dimensions (mm)	Carton Weight (kg's)	Pallet Qty.	Price
360473-AU	Rebel® 2 Automatic Vacuum Pool Cleaner	1067x387x229	6.5	25	\$1,430.63

*Terms and conditions apply



Mako Shark®

Automatic Inground Pool Cleaner



FEATURES:

- Superior vacuum power and extra-wide mouth capture large and small debris with ease.
- Superior seal design includes specially engineered “fingers” to assure the unit won’t get stuck or thrown off course by main drains, tight corners, eyeball fittings, and lights.
- Built-in bumper assures free movement around steps and ladders for total cleaning coverage and uninterrupted, hands-free operation.
- Installs in minutes without tools to skimmer.
- Sound dampening casing.
- 3 year limited warranty.

Mako Shark features many design elements shared by on of the most popular suction side cleaner in history, the Hammerhead™. Then we added performance features to make the Mako Shark relentless in its pursuit of dirt and debris, while keeping it affordable and sensationally dependable.

MAKO SHARK

MPG36

Code	Product	Carton Dimensions (mm)	Carton Weight (kg's)	Pallet Qty.	Price
M0721BG	Mako Shark Inground Pool Cleaner	1025x365x165	6.5	41	\$1,144.26

*Terms and conditions apply ^ Not suitable for vinyl liner pools.



Great White® II

For Inground Swimming Pools



FEATURES:

- 38cm wide cleaning path for faster cleaning.
- Oversized vacuum inlet for picking up large debris.
- SmartTrac™ programmed steering.
- Bristle-drive technology.
- 3 year limited warranty.*

The new Great White II Suction-Side Inground Cleaner is the solution to getting your pool sparkling clean. Just attach the hose, and its unique Bristle-Drive™ Technology goes to work scrubbing tough dirt from pool surfaces. Both small and large debris disappear into the oversized vacuum inlet for a complete and uninterrupted cleaning.

GREAT WHITE II

MPG36

Code	Description	Carton Dimensions (mm)	Carton Weight (kg's)	Pallet Qty.	Price
360151-AU	Great White II Automatic Pool Cleaner for Inground Pools	1060x300x225	8	30	\$1,240.91

*Terms and conditions apply

Extension Hoses

To Suit Automatic Pool Cleaners

EXTENSION HOSES

MPG36

Code	Description	Price
INDIVIDUAL HOSES		
BS59610	Blue Hose Standard (1.0m) - Rebel2/Mako/SandShark	\$29.95
800030	Blue Hose Leader (0.5m) - Rebel2	\$29.95
GW7911	Blue Hose Leader (0.36m) - SandShark	\$25.65
BS59611	Blue Hose Leader (1.0m) - MakoShark	\$29.95
59616	Aqua Hose Standard (1.0m) - Hamerhead	\$29.95
59619	Aqua Hose Leader (1.0m) - HammerHead	\$29.95
59867	Grey Hose Standard (1.0m) - GreatWhite/PoolShark	\$29.95
59380	Grey Hose Leader (0.36m) - PoolShark	\$25.65
41200-0132	Grey Hose Leader (1.0m) - GreatWhite	\$29.95
GW9510	Grey Hose (8.0m) - Lil' Shark	\$336.48
BULK P.O.S. HOSE PACKS		
800109	Blue Hose Standard 36pk (1.0m) - Rebel2/Mako/SandShark	\$860.28
800108	Aqua Hose Standard 36pk (1.0m) - Hamerhead	\$860.28
800110	Grey Hose Standard 36pk (1.0m) - GreatWhite/PoolShark	\$860.28
VACUUM HOSE		
5116500	9m x 38mm Vacuum Hose	\$205.23
5116501	12m x 38mm Vacuum Hose	\$258.92
5116502	15m x 38mm Vacuum Hose	\$313.81



POOL SANITIZERS

Posi-Chlor®

Salt Water Chlorinator



- FEATURES:**
- Adjustable chlorine production by high-efficiency switched mode power supply
 - Automatic switch-off owing to lack of water flow
 - Automatic switch-off owing to the accumulation of gas in the cell, with automatic restart once the water flow is restored
 - Automatic voltage adjustment depending on the concentration of salt and the temperature, ensuring continuous efficient chlorine production
 - Automatic and adjustable reverse polarity cleaning cycle
 - Battery backed-up time clock with automatic restart
 - Mineral salt compatible
 - Available in three configurations; **Basic** - with convenient adjustment of chlorine output, **pH** - with an automatic probe-free adjustment of pH, and **Advanced** - with probes and full automatic control of pH and chlorine (ORP).

Keep your pool water clear and inviting with electrolytic chlorine generation – the easiest, most effective and convenient way to maintain your pool. Simply adjust the output to achieve the precise level of chlorine. Posi-Chlor® does the rest, automatically producing a steady stream of chlorine for softer, silkier pool water that's free of bacteria and other contaminants. Nothing could be easier.

Posi-Chlor® Basic

Posi-Chlor® +pH

Posi-Chlor® Advanced



Temperature Probe (Optional)



With the addition of a temperature probe, Posi-Chlor® can calculate the salt level of your pool.

POSI-CHLOR® SALT WATER CHLORINATOR

MPG19

Code	Product	Supply Voltage	Chlorine Protection	Maximum Power	Cell Current	Protection	Max. Temperature	Price
811020	Posi-Chlor® 15	230-240VAC, 50/hz	15g/hr	112.5W	3.75A	IP65	40°C	\$1,189.39
811021	Posi-Chlor® 25		25g/hr	187.5W	5.75A	IP65	40°C	\$1,782.41
8110221	Posi-Chlor® 35		35g/hr	263W	8.75A	IP65	40°C	\$2,153.81
SWC-KITSALT	PRO Series Salt Sensor and Temperature Probe Kit							\$259.70



FreeFlo Chlorinator

Salt Water Chlorinator



MINERAL SALT COMPATIBLE



- FEATURES:**
- "Simple but Reliable".
 - Low salt operation: 3500-4500ppm (0.35% - 0.45%).
 - Over temperature protection.
 - High efficiency toroidal transformer.
 - Premium grade titanium cell.
 - Over current protection.
 - High quality Panasonic timer.
 - Reverse-polarity, self-cleaning cell.
 - Silicon controlled rectification.
 - Very high chlorine production.
 - Acrylic weather shield.
 - High impact ABS plastic cell housing.
 - Available in dual outlet models for connecting pH doser or lighting transformer.
 - Manufactured in Australia.
 - 3-Year full replacement power pack warranty. 5-Year pro-rata warranty on cell.

Electrolytic chlorine generation is the easiest, most effective and convenient way to keep pool water sparkling clean. Designed for the budget conscious pool owner, the FreeFlo series by Pentair live up to its motto "Simply Reliable".

The FreeFlo salt chlorinator is engineered to stand up to the toughest pool conditions and provide years of dependable service. The FreeFlo chlorinator can be connected to Pentair's solenoid dosing system for a pH perfect pool.

FREEFLO SALT WATER CHLORINATOR

MPG19

Code	Product	Cl Output (g/hr)	Cal. Hypo Equiv. (65%)	Sod. Hypo. Equiv. (12.5%)	Supply Voltage (VAC)	Output Voltage (VDC)	Output Current (A)	Carton Dim. (mm)	Carton Weight (kgs)	Pallet Qty.	Price
QUARTZ TIMER (BATTERY BACKUP)											
FFCL-15-RPD	FreeFlo Salt Chlorinator 15g/hr	15	23g	120ml	230-240	8.5	15	470x310x250	12	32	\$2,201.16
FFCL-25-RPD	FreeFlo Salt Chlorinator 25g/hr	25	38g	200ml	230-240	8.5	25	470x310x250	13	32	\$2,357.10
FFCL-35-RPD	FreeFlo Salt Chlorinator 35g/hr	35	54g	280ml	230-240	8.5	35	470x310x250	14	32	\$2,775.44
DUAL OUTLET											
FFCL-15-RP2	FreeFlo Salt Chlorinator 15g/hr	15	23g	120ml	230-240	8.5	15	470x310x250	12	32	\$2,279.13
FFCL-25-RP2	FreeFlo Salt Chlorinator 25g/hr	25	38g	200ml	230-240	8.5	25	470x310x250	13	32	\$2,435.07
FFCL-35-RP2	FreeFlo Salt Chlorinator 35g/hr	35	54g	280ml	230-240	8.5	35	470x310x250	14	32	\$2,854.90

*Terms and conditions apply



- FEATURES:**
- Auto Setup/Configuration wizard makes start-up quick and easy.
 - Programmable chemical feed cycle and mix times for precise water balance.
 - Assures safe water conditions by preventing excess chemical addition.
 - Built in Langelier Saturation Index calculator lets you know when your water chemistry is perfectly in or out of balance.
 - Minimizes chemical costs by adding chemicals with precision.
 - Flow sensor ensures chemicals won't feed without system flow.
 - Password-protected access prevents tampering or accidental program change.
 - Seamless interface with IntelliTouch®, EasyTouch®, SunTouch®.
 - Automation Systems and ScreenLogic2™ Interface for superior chemical management.
 - Compatible with external dosing pumps, and CO2 systems.
 - 2-Year limited warranty*.

The IntelliChem Chemical Controller automatically monitors pool pH and sanitizing levels and delivers just the right amount of chemicals. IntelliChem Chemical Controller can work independently or in conjunction with other Pentair automation products. It's built-in Langelier Saturation Index calculator lets pool owners know when the water is in or out of balance. IntelliChem Chemical Controller uses the same technology found in commercial installations, water parks, hotel and community pools.

INTELLICHEM CHEMICAL CONTROLLER								MPG16
Code	Product	Application	Supply Voltage (VAC)	Full Load Current (A)	Carton Dim. (mm)	Carton Weight (kgs)	Pallet Qty.	Price
521357-AU	IntelliChem with no pumps	For systems using external feed pumps, or external sanitation systems.	230-240	1.2	584x355x254	4	20	\$4,216.38
521489-AU	IntelliChem with 1 pump	For systems using salt chlorinator and acid.	230-240	1.2	584x355x254	4.2	20	\$4,628.72
521355-AU	IntelliChem with 2 pumps	For systems using liquid chlorine and acid.	230-240	1.2	584x355x254	4.85	20	\$5,165.52

*Terms and conditions apply



- FEATURES:**
- 300 and 320 series filters available in clear amber for easy tablet level monitoring.
 - Completely enclosed system – no special venting required.
 - No escaping gases.
 - 345kPa / 50psi maximum operating pressure.
- In-Line Feeders**
- **320 Series.** For permanent installation in return line of new or existing pools or spas. Installs in return line on pressure side of pump downstream of all equipment. Standard with 2" slip PVC fittings and adapters for 1-1/2".
- Off-Line Feeders**
- **300 Series.** Retrofits into existing pools or spas. Operates on pressure side of pump. Uses 1/4" feeder hoses, control valve and fittings.
 - 1-Year full replacement warranty.
- Years of customer use and satisfaction have proven Rainbow feeders to be the performance leader in pool & spa chemical dispensers.

RAINBOW AUTOMATIC CHLORINE / BROMINE FEEDERS						MPG19
Code	Model	Description	Carton Quantity	Carton Weight (kgs)	Price	
IN-LINE FEEDERS						
R171096	320	Holds 11 large or 98 small Bromine or slow dissolving Trichlor tablets. Treats 25,000 to 100,000 litres bottom feed and 68,000 to 265,000 litres top feed.	1	15	\$328.37	
R171218	320C	Holds 11 large or 98 small Bromine or slow dissolving Trichlor tablets. Treats 25,000 to 100,000 litres in a bottom feed configuration and 68,000 to 265,000 litres in a top feed configuration with see-through amber body.	1	15	\$328.37	
OFF-LINE FEEDERS						
R171016	300	Holds 11 large or 98 small tablets. Treats 45,000 to 180,000 litres.	1	13	\$376.36	
R171026	302	Spa feeder. Includes spa chamber. Treats 2000 to 7500 litres. Holds 15 small tablets.	1	14	\$393.60	
COMMERCIAL AND HIGH CAPACITY FEEDERS						
R171230	HC-3330	High capacity for 1 in. hard plumbing installations. Holds 15kg of tablets. Treats up to 150,000 litres with Bromine and up to 600,000 litres with Trichlor.	1	6	\$856.17	

*Terms and conditions apply

IntelliChlor

Salt Chlorine Generator



FEATURES:

- Transform your pool with ordinary table salt.
- Full diagnostic capabilities, including cell-life tracking that communicates remaining hours of cell life in real-time
- Push-button operation and easy-to-view displays enable fast checking of salt levels, cell cleanliness, sanitizer output and water flow
- Automatic shut-off feature protects the unit and prolongs cell life under low-water-temperature conditions
- On-time cycling prevents calcium and scale buildup to maximize cell life
- Communicates with IntelliTouch®, EasyTouch® and SunTouch® Automation Systems

A salt chlorine generator that turns salt into water-purifying chlorine.

IntelliChlor uses common table salt to produce all the chlorine a pool needs, safely, effectively and automatically. It provides the same sanitation performance as harsh chlorine additives without the drawbacks. There's no need to buy, handle and store chemicals.

PLEASE NOTE: The IntelliChlor is only available with Pentair Automation Systems.

INTELLICHLOR SALT CHLORINE GENERATOR

		MPG16
Code	Product	Price
523010	IntelliChlor Cell 10g/hr (IC15)	\$1,392.97
523009	IntelliChlor Cell 20g/hr (IC30)	\$1,587.89
520555	IntelliChlor Cell 30g/hr (IC40)	\$1,857.79
521105	IntelliChlor Cell 40g/hr (IC60)	\$2,217.65

*Terms and conditions apply





FEATURES:

- Easy to use, intuitive user interface on touchscreen interfaces with multiple controller options.
- Built-in connectivity for iOS and Android mobile digital devices, including the Apple Watch® wrist wearable devices and Amazon Echo®.
- Controls pools remotely from anywhere in the world including at home, abroad or work.
- Pumps, heat pumps, chemical controllers, gas heaters and more can be controlled by IntelliCenter.
- Almost limitless control capability with multiple unit connection multi-body control. Connect up to 4 pools.
- Optional IntelliChlor chlorinator add-on for smart sanitizer control.
- 2-Year Warranty*

Give your customers the ultimate control over their backyard paradise with IntelliCenter Control System for Pool and Spa! The new IntelliCenter makes it easier and more intuitive than ever for customers to control their pool with their familiar iOS® or Android® mobile devices from anywhere in the world.

IntelliCenter features new color touchscreen interfaces at the equipment pad as well as via an optional wireless poolside remote. Its razor-sharp screen clarity and step-by-step instructions make operation a cinch. IntelliCenter also has enhanced voice command capabilities, has built-in connectivity for iOS and Android mobile digital devices and can even provide real-time email alerts when an issue requires attention.

INTELLICENTER POOL AUTOMATION SYSTEMS

MPG16

Code	Description	High Voltage Circuits	Carton Dimensions (mm)	Carton Weight (kg)	Pallet Qty.	Price
521904-AU	IntelliCenter i8PS - Pool Automation System for Pool/Spa Combo Systems	8	550x470x180	20	24	\$6,963.41
521915-AU	IntelliCenter i10D - Pool Automation System for Dual Body Pool & Spa Systems	10	550x470x180	20.5	24	\$6,963.41
INTELLICENTER POOL AUTOMATION SYSTEMS for INTELLICHLOR						
521903-AU	IntelliCenter i8PS for IntelliChlor - Pool Automation System for Single Body or Pool/Spa Combo Systems. Includes IntelliChlor Power	8	550x470x180	21	24	\$7,247.39
INTELLICHLOR CELLS (ONE REQUIRED WITH ABOVE UNITS)						
523010	IntelliChlor Cell 10g/hr (IC15)					\$1,392.97
523009	IntelliChlor Cell 20g/hr (IC30)					\$1,587.89
520555	IntelliChlor Cell 30g/hr (IC40)					\$1,857.79
521105	IntelliChlor Cell 40g/hr (IC60)					\$2,217.65

iPhone®, iPad®, and iPod Touch® are registered trademarks of Apple Inc.

Multiple selections of the following interfaces can be used with the IntelliCenter automation system.



Wireless Control



SpaCommand



iS4



IntelliValve



Valve Expansion Module



Pool Cover Input Card



Wifi Range Extender



Standard CVA

INTELLICENTER ACCESSORIES

MPG16

Code	Description	Price
INTELLICENTER CONTROL INTERFACES		
520138-AU	IntelliCenter Wireless Remote (incl. transceiver, charge cradle and wall mount)	\$1,961.59
SPA-SIDE REMOTES		
521178	SpaCommand Remote, White with 150 ft. cable	\$1,233.75
521176	SpaCommand Remote, Black with 150 ft. cable	\$1,233.75
521887	iS4 Remote with 150ft cable (White)	\$334.09
521888	iS4 Remote with 150ft cable (Grey)	\$334.09
521893	iS4 Remote with 150ft cable (Black)	\$334.09
VALVE ACTUATORS		
521485	IntelliValve Digital Valve Actuator	\$810.17
263045	Standard Valve Actuator (CVA)	\$462.95
ACCESSORIES		
522038Z	Valve expansion module (add 6 valve actuators)	\$420.00
522039Z	Pool cover input card	\$533.35
522475Z	High power wifi range extender	\$884.66
ES03	Emergency Shut-Off Switch w/Audible Alarm	\$1,322.05
520818	Com Port Expansion Module	\$266.08
RYALX	Adaptor to connect 2 relays off one auxiliary output	\$257.73
CRALX	Adaptor to run 1 relay off either of two auxiliary outputs	\$257.73
522101	Solar Temperature Sensor	\$52.38

EasyTouch® Control Systems

Pool/Spa Control Systems



EasyTouch® Control Systems

Accessories



EasyTouch System



(bottom view of the control panel unit)



FEATURES:

- Gas Heater, Heat Pump & Solar Control.
- Support for 2 IntelliFlo Pumps.
- 8 Feature circuits.
- IntelliChem® Controller support
- ScreenLogic2™ Mobile Interface
- Light & Water Feature support
- Spa-side remotes.
- IntelliChlor Salt Chlorinator Option.
- All functions controlled with easy, one-button access from the self-contained load center or optional controllers. No need to memorise operating sequences, open and close valves, or reset time clocks and thermostats.
- Now incorporating built in electrical outlets for lower cost installation. PNP 10 unit includes 10 outlets - 8 Auxiliaries plus 2x 15A permanent power. PNP 5 unit includes 5 outlets - 4 Auxiliaries plus 1x 15A permanent power.
- 2 year Warranty*

EasyTouch® allows full control of all pool/spa features including advanced features such as coloured lighting. Every EasyTouch® system includes an easy to use control panel that is built into the outdoor enclosure. In addition, there are several other available remote interface choices including Pentair's Screenlogic mobile interface. EasyTouch® now offers built in IntelliChlor power and control for plug-n-play connection to your IntelliChlor salt cell, no extra boxes or wiring required.

EASYTOUCH CONTROL SYSTEMS

MPG16

Code	Description	High Voltage Circuits	Valve Actuators (Included/Optional)	Carton Dimensions (mm)	Carton Weight (kg)	Pallet Qty.	Price
EASYTOUCH® PNP (PLUG-N-PLAY) SYSTEMS with built in electrical outlets							
520538-PNP	EasyTouch 5 PNP Pool/Spa or Single Body	5	0/4	550x470x180	20	20	\$3,340.91
520540-PNP	EasyTouch 10 PNP Pool/Spa or Single Body	10	0/4	550x470x180	20	20	\$3,546.14
EASYTOUCH SYSTEMS hard wired							
520540-AU	EasyTouch 8 – Pool/Spa	8	2/4	990x533x241	27	18	\$4,091.93
EASYTOUCH® PNP (PLUG-N-PLAY) SYSTEMS WITH INTELLICHLOR POWER							
520538-PNP-IC	EasyTouch 5 PNP Pool/Spa or Single Body	5	0/4	550x470x180	20	20	\$3,823.53
520540-PNP-IC	EasyTouch 10 PNP Pool/Spa or Single Body	10	0/4	550x470x180	20	20	\$3,830.11

Multiple selections of the following interfaces can be used with the EasyTouch automation system.



Indoor Control Panel



SpaCommand



iS4



IntelliValve



Wireless Control



ScreenLogic



Wireless Transceiver



Standard CVA

EASYTOUCH ACCESSORIES

MPG16

Code	Description	Price
EASYTOUCH CONTROL INTERFACES		
520548	EasyTouch ICP (Indoor Control Panel) for 4 circuit systems (PNP 5)	\$535.74
520549	EasyTouch ICP (Indoor Control Panel) for 8 circuit systems (PNP 10)	\$613.30
520546	EasyTouch Wireless Controller Kit for 4 circuit system, including transceiver (PNP 5)	\$1,459.26
520547	EasyTouch Wireless Controller Kit for 8 circuit system, including transceiver (PNP 10)	\$1,534.43
520500-AU	ScreenLogic2 Mobile Digital Device & Computer Interface Kit	\$1,361.48
SPA-SIDE REMOTES		
521178	SpaCommand Remote, White with 150 ft. cable	\$1,233.75
521176	SpaCommand Remote, Black with 150 ft. cable	\$1,233.75
521887	iS4 Remote with 150ft cable (White)	\$334.09
521888	iS4 Remote with 150ft cable (Grey)	\$334.09
521893	iS4 Remote with 150ft cable (Black)	\$334.09
VALVE ACTUATORS		
521485	IntelliValve Digital Valve Actuator	\$810.17
263045	Standard Valve Actuator (CVA)	\$462.95
ACCESSORIES		
520639	High Power Wireless Connection Kit – Includes 2 radio transmitters (optional for Screenlogic)	\$2,022.44
ES03	Emergency Shut-Off Switch w/Audible Alarm	\$1,322.05
520818	Com Port Expansion Module	\$266.08
RYALX	Adaptor to connect 2 relays off one auxiliary output	\$257.73
CRALX	Adaptor to run 1 relay off either of two auxiliary outputs	\$257.73
522101	Solar Temperature Sensor	\$52.38

EasyTouch® Control Systems

Pool/Spa Control Systems



MPG16				
Code	Description	High Voltage Circuits	Valve Actuators (Included / Optional)	Price
EASYTOUCH® PNP (PLUG-N-PLAY) SYSTEMS + SCREENLOGIC				
520538-PNP-SL	EasyTouch® PNP 5 + ScreenLogic	5	0/4	\$3,839.66
520540-PNP-SL	EasyTouch® PNP 10 + ScreenLogic	10	0/4	\$4,069.94
520538-PNP-2V-SL	EasyTouch® PNP 5 + 2xCVA's+ ScreenLogic	5	2/4	\$4,300.23
520540-PNP-2V-SL	EasyTouch® PNP 10 + 2xCVA's+ ScreenLogic	10	2/4	\$4,531.70
520538-PNP-2IV-SL	EasyTouch® PNP 5 +2x IntelliValve + ScreenLogic	5	2/4	\$4,606.88
520540-PNP-2IV-SL	EasyTouch® PNP 10 +2x IntelliValve + ScreenLogic	10	2/4	\$4,839.55
EASYTOUCH® PNP (PLUG-N-PLAY) SYSTEMS				
520538-PNP-2V	EasyTouch® PNP 5 + 2x CVA's	5	2/4	\$3,678.58
520540-PNP-2V	EasyTouch® PNP 10 + 2x CVA's	10	2/4	\$3,877.84
520538-PNP-2IV	EasyTouch® PNP 5 + 2x IntelliValve	5	2/4	\$4,100.97
520540-PNP-2IV	EasyTouch® PNP 10 + 2x IntelliValve	10	2/4	\$4,190.45
EASYTOUCH® PNP (PLUG-N-PLAY) SYSTEMS + SCREENLOGIC + INTELLICHLOR				
520538-PNP-IC-SL	EasyTouch® PNP 5 +IntelliChlor Power + ScreenLogic	5	0/4	\$4,123.64
520540-PNP-IC-SL	EasyTouch® PNP 10 +IntelliChlor Power + ScreenLogic	10	0/4	\$4,353.92
520538-PNP-IC-2V-SL	EasyTouch® PNP 5 +IntelliChlor Power + 2xCVA's+ ScreenLogic	5	2/4	\$4,837.14
520540-PNP-IC-2V-SL	EasyTouch® PNP 10 +IntelliChlor Power + 2xCVA's+ ScreenLogic	10	2/4	\$5,081.55
520538-PNP-IC-2IV-SL	EasyTouch® PNP 5 +IntelliChlor Power +2x IntelliValve + ScreenLogic	5	2/4	\$5,161.02
520540-PNP-IC-2IV-SL	EasyTouch® PNP 10 +IntelliChlor Power +2x IntelliValve + ScreenLogic	10	2/4	\$5,405.43
EASYTOUCH® PNP (PLUG-N-PLAY) SYSTEMS + INTELLICHLOR				
520538-PNP-IC	EasyTouch® PNP 5 +IntelliChlor Power	5	0/4	\$3,624.89
520540-PNP-IC	EasyTouch® PNP 10 +IntelliChlor Power	10	0/4	\$3,830.11
520538-PNP-IC-2V	EasyTouch® PNP 5 +IntelliChlor Power + 2xCVA's	5	2/4	\$3,963.75
520540-PNP-IC-2V	EasyTouch® PNP 10 +IntelliChlor Power + 2xCVA's	10	2/4	\$4,163.01
520538-PNP-IC-2IV	EasyTouch® PNP 5 +IntelliChlor Power +2x IntelliValve	5	2/4	\$4,384.94
520540-PNP-IC-2IV	EasyTouch® PNP 10 +IntelliChlor Power +2x IntelliValve	10	2/4	\$4,474.43

SCREENLOGIC MOBILE INTERFACE FOR EASYTOUCH



FEATURES:

- Use an Apple® iPad®, iPhone®, iPod touch®, Watch or Android® Mobile Digital Device to control pool functions from anywhere
- Remotely manage from a Mac® Computer or a PC using the ScreenLogic2 Interface.
- Easily change, track and monitor history of pH and ORP levels when using the new IntelliChem® Chemical Control System with IntelliTouch® or EasyTouch® Automation
- ScreenLogic2 Interface app allows full color lighting control for both IntelliBrite® LED lights and water features.

ScreenLogic2® for: iPhone®, iPad®, Android®, PC, Mac®, Apple Watch®



SunTouch® Control Systems

Pool/Spa Control Systems



FEATURES:

- One touch function – no complicated routine to memorize.
- Ability to program pool and spa and two additional features. All circuits in the system can control four operating schedules (maximum six total schedules per system).
- Supports 4 feature circuits for programming convenience.
- Compatible with gas or electric heaters, heat pumps, and solar systems.
- Temperature control can be set in one degree increments.
- Supports one IntelliFlo® Pump and IntelliChem® Chlorinator.
- 1-Year In-Field Warranty.



SunTouch® Control System is the easy way to keep your pool and spa clean, comfortable, and ready to enjoy. With the touch of a few buttons, you can quickly program your pool and spa filtration and heating cycles to fit your schedule. And it's just as simple to change programs or switch to manual mode for those unplanned, spontaneous plunges.

With SunTouch® Control System, your pump and heater automatically run whenever you want, for as long as you want so your pool and spa are always warm and inviting. In addition to controlling your pump and heater, the standard SunTouch® Control System package has the ability to schedule operation of additional functions, such as your lights or automatic cleaner. You can also add a third valve actuator to automate a solar heating system or water feature.

SUNTOUCH® CONTROL SYSTEMS

MPG16							
Code	Description	No. Relays	Valve Actuators (Standard / Optional.)	Carton Dim. (mm)	Carton Weight (kgs)	Pallet Qty.	Price
520820-AU	SunTouch® Control System (pool/spa)	3	2 / 3	368x330x304	8	27	\$2,374.43
520859-AU	SunTouch® Single Body Control System	3	0 / 3	403x295x190	4.8	60	\$1,850.63
ACCESSORIES							
MPG48							
520106	3HP Relay						\$142.58
ES03	Emergency Shut-Off Switch w/Audible Alarm						\$1,394.46
263045	Valve Actuator						\$462.95
522101	Solar Temperature Sensor						\$52.38

Guide to Pool Controls

SunTouch®, EasyTouch® and IntelliCentre®



SunTouch®



EasyTouch®



IntelliCentre®

	POOL or SPA Shared equipment	POOL or SPA Shared equipment	POOL or SPA Shared equipment Dual body of water
No. Power Relay Circuits	Three Relays	4/8 Relay configurations	Up to 40 relay support
No. Virtual Circuits	4 Feature Circuits	8 Feature Circuits	32 Feature Circuits 16 Macro Circuits
Variable Speed Pumps	IntelliFlo Support 1 IntelliFlo Maximum	IntelliFlo Support 2 IntelliFlo's Maximum	IntelliFlo Support 16 IntelliFlo's Maximum
VS Pump Speeds	8 Programmable speeds	8 Programmable speeds per pump	8 Programmable speeds per pump
2 Speed Pump Control	Yes	Yes	Yes
No. Valve Actuators	Up to 3 Actuator Valves (Intake, Return + 1 Assigned)	Up to 4 Actuator Valves (Intake, Return + 2 Assigned)	Up to 40 Actuator Valves
No. Programs	24 hours programming 6 Programs maximum	24 Hours 7 Days Program 12 Programs maximum	24 Hours 7 Days Program 100 Programs maximum
Chemical Control	External chlorinator	IntelliChem Support	IntelliChem Support
iOT Mobile Device Support	No	With ScenLogic 2	Built-in
Heating	Gas Heater, Solar & Heat Pump Control	Gas Heater, Solar & Heat Pump Control	Gas Heater, Solar & Heat Pump Control
Spa-Side Control	No Spa Side Control	is4 Spa side remote (x1) Spa command (x1)	is4 Spa side remote (x2) 4x Spa command (x4)
Control Panels	Outdoor Control Panel	Outdoor Control Panel Indoor Control Panel Wireless Control Panel	Outdoor Control Panel Wireless Control Panel
Lighting	No Lighting Control	Color lighting control Color swim, set and sync	Color lighting control Color swim, set and sync
Home Automation Interface	No	No	Yes, Built-in
Water Bodies	Single or Pool/Spa combo	Single or Pool/Spa combo	Up to 4 Separate Water Bodies



IntelliValve®

Valve Actuator



FEATURES:

- Exclusive thirteen (13) LEDs give precise, easy to read indication of valve position.
- Built-in interface allows quick and simple set-up of water flow.
- Sleek, minimalist design is compact and fits easily within any equipment pad.
- Sealed, maintenance-free design is weatherproofed for maximum reliability and extended service life.
- Suitable for 1.5", 2", 2.5" and 3" valve sizes.
- 24-volt operation for use with standard automation systems.
- 750 mA max amp draw.
- Adjustable 3.75-degree increments within the maximum 180-degree swing.
- 2 years limited warranty.

The revolutionary IntelliValve Valve Actuator lets you set just the right flow for water features. Its intuitive controls and LED position indicator lights make operation fast and pushbutton easy.

Thirteen (13) bright LEDs provide a clear visual indication of the valve position from fully open to fully closed and everywhere in between. Simply use the clockwise/anticlockwise and save buttons to set the perfect flow rate in just seconds.

INTELLIVALVE VALVE ACTUATOR

MPG16

Code	Description	Carton Qty	Price
521485	IntelliValve - Valve Actuator	8	\$810.17

GloBrite® LED Lights

Shallow Water LED



FEATURES:

- The brightest and most efficient LEDs available.
- Can be placed in as little as 4 in. of water.
- Does not require grounding or bonding for quick and easy installations.
- 5 brilliant fixed colours and 7 pre-programmed light shows.
- Compatible with IntelliTouch® or EasyTouch® Control Systems for advanced control features.
- Compliments IntelliBrite® 5g LED Pool Lighting using the same fixed colors and colour shows.
- Compatible with gunite, fiberglass and vinyl pools.



GloBrite LED Lights use advanced technology for energy efficient, high quality light displays, delivered with enhanced LED brightness and superior optics, while using 18% less energy than other shallow water LED lights.

GloBrite lights are compatible with IntelliTouch and EasyTouch control systems and IntelliBrite LED pool lights. GloBrite LED lighting is a brilliant way to showcase and enhance pool features like baja shelves, steps, beach entries and shallow water features.

GLOBRITE LED LIGHTS

MPG35

Code	Description	Voltage (VAC)	Power (W)	Luminosity (lm)	Cord Length (m)	Carton Dim. (mm)	Carton Weight (kgs)	Pallet Qty.	Price
602053	GloBrite Shallow Water LED Light (10m cable)*	12	15	700	10	330x330x130	2.3	36	\$661.02
602054	GloBrite Shallow Water LED Light (15m cable)*	12	15	700	15	330x330x130	2.7	36	\$700.40
602055	GloBrite Shallow Water LED Light (30m cable)*	12	15	700	30	330x330x130	5.4	36	\$733.81
GLOBRITE NICHES									
620040	Concrete Niche for GloBrite					210x115x110	1		\$109.77
620039	Vinyl Niche for GloBrite					210x115x110	1		\$125.28
620041	Fibreglass Niche for GloBrite					210x115x110	1		\$125.28
ACCESSORIES									
800130	Transformer 12VAC 30VA Single Output (1 Light/Feature)								\$221.93
800131	Transformer 12VAC 60VA Dual Output (2 Lights/Features)								\$312.61
800132	Transformer 12VAC 120VA Quad Output (4 Lights/Features)								\$386.59
802014	Junction Box								\$34.60



IntelliBrite® Compatible LED Lights

By Spa Electrics

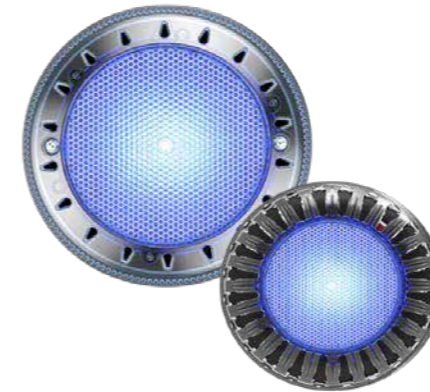

IntelliBrite Compatible LED lights

FEATURES:

- High intensity Ceramic light Engine (LED) technology.
- Market leading brightness and efficiency.
- Multi Colour RGB light source.
- Direct Connection Patented detachable electrical connection.
- Clear Rim Colour.
- Suitable for Concrete and Fibreglass pools.
- IPX8 waterproof rating.



IntelliBrite compatible LED lights from Spa Electrics represent a new generation in pool lighting. IntelliBrite lights feature 12 different operating modes and a RGB + White LED array, providing beautifully clean white illumination and sunning colour shows.

IntelliBrite lights are fully compatible with IntelliTouch® and EasyTouch® control systems, providing a range of options from indoor control panels to wireless remotes or screen logic on your computer or favourite mobile device. This allows you to operate your pool lights via the standard wall switch, control panel or mobile app.

INTELLIBRITE COMPATIBLE LED LIGHTS

MPG24

Code	Description	Voltage (VAC)	Power (W)	Price
805000	Atom EMC Multi Plus LED Light + Concrete Niche + 20m Cable + LV25 Transformer (1 Pack)	12	12	\$1,576.28
805001	Atom EMC Multi Plus LED Light + Concrete Niche + 20m Cable + LV50 Transformer (2 Pack)	12	12	\$3,035.67
805002	Quantum WNC Multi Plus LED Light + Concrete Niche + 20m Cable + LV25 Transformer (1 Pack)	12	12	\$1,576.28
805003	Quantum WNC Multi Plus LED Light + Concrete Niche + 20m Cable + LV50 Transformer (2 Pack)	12	12	\$3,035.67
805004	Atom EMF Multi Plus LED Light + F/Glass Niche + 20m Cable + LV25 Transformer (1 Pack)	12	12	\$1,407.17
805005	Atom EMF Multi Plus LED Light + F/Glass Niche + 20m Cable + LV50 Transformer (2 Pack)	12	12	\$2,405.14
805006	Quantum WNF Multi Plus LED Light + F/Glass Niche + 20m Cable + LV25 Transformer (1 Pack)	12	12	\$1,407.17
805007	Quantum WNF Multi Plus LED Light + F/Glass Niche + 20m Cable + LV50 Transformer (2 Pack)	12	12	\$2,405.14

MagicStream® Laminar

LED Water Feature



FEATURES:

- The perfect complement to LED Pool Lighting for dynamic and synchronized coloured light shows.
- Provides 5 brilliant fixed colours, 7 dazzling light shows.
- Laminar water streams can reach up to 2m high and project outward up to 2.5m into your pool, spa, or other water feature.
- Installation is made flush to your deck or other surface; no unsightly or unsafe edges, just the magic of water erupting from a hidden source.
- Water streams are easily adjusted in two ways - vertically from 62 degrees to 75 degrees to create different heights and arc shapes. Left and right direction can be adjusted up to 60 degrees total.
- Laminar deck lids are available in tan, black, and gray to match or complement pool deck or other installation surface.
- Simply connect to a pool lighting transformer to provide power.
- 12VAC transformer not included.

MagicStream® Laminars create totally clear, uniform arcs of moving water that originate from either your pool deck or surrounding landscape. At night, these translucent streams are brilliantly coloured with an LED light source. The result is a water effect that adds an elegant bit of entertainment to your poolscape. It is fully compatible with the IntelliBrite line of LED pool lights and the EasyTouch® or IntelliTouch® Automation Systems.

MAGICSTREAM LAMINARS

MPG35

Code	Description	Voltage (VAC)	Power (W)	Cord Length (m)	Carton Dimensions (mm)	Carton Weight (kg)	Pallet Qty.	Price	
580001B	Laminar LED, Black Lid	12	16	30	350x350x570	11.5	18	\$2,410.23	
580001G	Laminar LED, Grey Lid	12	16	30	350x350x570	11.5	18	\$2,410.23	
580001T	Laminar LED, Tan Lid	12	16	30	350x350x570	11.5	18	\$2,410.23	
ACCESSORIES									
800130	Transformer 12VAC 30VA Single Output (1 Light/Feature)								\$221.93
800131	Transformer 12VAC 60VA Dual Output (2 Lights/Features)								\$312.61
800132	Transformer 12VAC 120VA Quad Output (4 Lights/Features)								\$386.59
802014	Junction Box								\$34.60

MAGICSTREAM LAMINARS PERFORMANCE

Parameter	Value	Value	Value
Litres	22.7	28.3	32.1
Inlet Pressure (Kpa)	17.2	24.1	31
Height of jet (metres)	1.52	1.82	2.12



ColourVision® LED Light Bubbler

LED Water Bowl



FEATURES:

- Energy efficient colour LED lights with vibrant colours.
- Provides 5 brilliant fixed colours, 7 dazzling light shows.
- Designed for 5 - 25cm of water depth.
- Plume height up to 60cm.
- Low voltage operation of 12 VAC / 15W.
- Low flow requirements allow for multiple units per pool.
- PVC niche provides for flush mounting.
- The perfect complement to IntelliBrite® LED Pool Lighting for dynamic & synchronized coloured light shows.

The ColorVision® bubbler goes from a spectacular display of moving water to a lighted, magical escape with included GloBrite® LED colour changing lighting. Whether you're in the mood to relax or entertain, ColorVision® bubblers are the perfect way to showcase and enhance your pool features.

DIMENSIONS & PERFORMANCE

GPM	WATER DEPTH									
	5cm		10cm		15cm		20cm		25cm	
	PLUME HEIGHT (CM)									
	Nozzle Diameter									
	1/2"	3/4"	1/2"	3/4"	1/2"	3/4"	1/2"	3/4"	1/2"	3/4"
60		30	60	20	40	18	30	13	23	10
80		50		33		30	48	18	38	15
100				53		38		25	60	20
120						58		38		30
140								43		35
160								53		43
180										50



COLOURVISION LED LIGHT BUBBLER

MPG35

Code	Description	Voltage (VAC)	Power (W)	Cord Length (m)	Carton Dimensions (mm)	Carton Weight (kg)	Pallet Qty.	Price	
580037-AU	ColorVision Bubbler Kit Concrete Incl. Glo-Brite LED (15m cord)	12	15	15	300x300x400	4.7	18	\$1,135.91	
580036-AU-30	ColorVision Bubbler Kit Fibreglass/Vinyl Incl. GloBrite LED (30m cord)	12	15	30	300x300x500	6.7	18	\$1,233.75	
580036-AU	ColorVision Bubbler Kit Fibreglass/Vinyl Incl. GloBrite LED (15m cord)	12	15	15	300x300x400	4.7	18	\$1,135.91	
580037-AU-30	ColorVision Bubbler Kit Concrete Incl. Glo-Brite LED (30m cord)	12	15	30	300x300x500	6.7	18	\$1,233.75	
ACCESSORIES									
800130	Transformer 12VAC 30VA Single Output (1 Light/Feature)								\$221.93
800131	Transformer 12VAC 60VA Dual Output (2 Lights/Features)								\$312.61
800132	Transformer 12VAC 120VA Quad Output (4 Lights/Features)								\$386.59

*Can be later fitted with a GloBrite LED light ordered separately.

Deck Jet & Deck Jet II

LED Water Feature



Deck Jet

Deck Jet II



FEATURES:

Deck Jet

- Deck Jet includes five interchangeable water effect eyeballs that are easy to remove and simple to change. Also Includes construction shield.
- Streams reach to eight feet, and direction can be easily adjusted
- Low water pressure requirement for minimum impact on pump performance

Deck Jet II

- Height is adjustable to a maximum of six feet. Water direction is adjustable up to 360 degrees.
- Easy-to adjust nozzles enable your creativity: concentrate all streams into a single entry point, overlap streams of different heights, or create a symmetrical, multi-stream archway...and more
- Quality design assures low water flow requirements and eliminates any concerns about standing water or unwanted debris collection
- Attractive installation with no unsightly or unsafe edges or screws

Deck Jet water effects can be cast into concrete decks and gunite pool walls, mounted in the sidewall of aboveground and vinyl-lined pools, or blended into surrounding landscapes.

MagicStream® Deck Jet II creates a graceful arc of water that enters the pool with a gentle splash. The stream seems to appear magically from the pool deck since the jet installs flush and out of sight.



DECK JETS

					MPG35
Code	Description	Plumbing	Carton Dimensions (mm)	Carton Weight (kg)	Price
580000	Deck Jet	40mm	180x105x105	0.6	\$423.58
580003	Magic Stream® Deck Jet II (4 jets included)	20mm	150x150x150	0.9	\$607.33
TRIPLE SPRAY					
1090100	Triple Spray (pack of 10)	20mm	150x150x150	0.9	\$137.22
1090300	Triple Spray Wall Sockets (pack of 10)	20mm	-	-	\$111.68



Pool Lighting Transformers

Multi-Output Pool Lighting Transformers



FEATURES:

- The perfect complement to LED Pool Lighting for dynamic and synchronized coloured light shows
- Incorporates power outlet to allow daisy-chain of multiple lighting transformers.
- A single transformer powers up to 4 lights, each individually fused and electrically isolated.
- Complies with Australian Standards.

Pentair lighting transformers allow for easy connection of pool lighting. Available in one, two or four light versions and with an outlet for connecting additional transformers, you can connect all your lights from one GPO. Outputs are electrically isolated.



POOL LIGHTING TRANSFORMERS

				MPG35
Code	Description	Voltage (VAC)	Power (W)	Price
800130	Lighting Transformer 30VA 1-Light	12	30	\$221.93
800131	Lighting Transformer 60VA 2-Lights	12 x2	30 x2	\$312.61
800132	Lighting Transformer 120VA 4-Lights	12 x4	30 x4	\$386.59

MegaSkim Skimmer

Skimmers for In-Ground Pools



- FEATURES:**
- Massive leaf basket (6.7L), for long intervals between cleaning.
 - Patented child-safe lockable lid, locks with ¼ turn of Philips head screwdriver (no special tool required).
 - Compliant to AS/NZS 1926.3.
 - Single piece moulded body, for long-term strength.
 - Ample points for securing to concrete reinforcement.
 - Rear (standard) and Base (punch-out) plumbing ports. 50mm AS/NZS PVC, Slip fit sockets.
 - Vacuum plate with flow control valve, included with every model.
 - Multi-fit fibreglass flange screw pattern allows retrofit for Quiptron, Poolrite and Waterco skimmers.
 - Available for concrete, fibreglass and vinyl liner pools.
 - Available with extension throat and wide-mouth throat.

The Pentair MegaSkim is the ideal skimmer for every new pool. Designed with both the pool builder and pool owner in mind, the MegaSkim is easy to install and easy to use. For the pool builder, the skimmer body is constructed out of a single piece mould, with no glue joins for potential leaks. Plenty of attachment points for tying to reinforcement are included, as well as base and rear plumbing ports to make installation easy. The MegaSkim is made from a tough UV stabilised thermoplastic, for years of use in the tough Australian climate. For the pool owner, the MegaSkim has a massive leaf basket for long intervals between cleaning. The MegaSkim is compliant to Australian Standards with a patented* child safe deck lid.

CONCRETE POOL SKIMMERS

MPG17

Code	Description	Skimmer			Lid		Carton Dimensions (mm)	Carton Weight (kg)	Pallet Qty.	Price
		Pool	Extension	Colour	Shape	Colour				
810000	Skimmer Pool Megaskim Concrete (No lid)	Concrete	None	White	None	None	590x455x320	16	5.8	\$396.14
810001	Megaskim Concrete Square Lid (Tan)	Concrete	None	White	Square	Tan	590x455x320	16	6.0	\$508.30
810002	Megaskim Concrete Round Lid (Tan)	Concrete	None	White	Round	Tan	590x455x320	16	6.0	\$508.30
810003	Megaskim White Concrete Square Lid (Grey)	Concrete	None	White	Square	Grey	590x455x320	16	6.0	\$508.30
810004	Megaskim White Concrete Round Lid (Grey)	Concrete	None	White	Round	Grey	590x455x320	16	6.0	\$508.30
810100	Skimmer Pool Megaskim Con. W/ Mouth (No lid)	Concrete	Widemouth	White	None	None	660x590x545	8	8.4	\$508.30
810101	Megaskim Concrete W/ Mouth Sq. Lid	Concrete	Widemouth	White	Square	Tan	660x590x545	8	8.6	\$625.23
810102	Megaskim Concrete W/ Mouth Sq. R	Concrete	Widemouth	White	Round	Tan	660x590x545	8	8.6	\$625.23
810200	Skimmer Pool Megaskim Con. Ext/Thr (No Lid)	Concrete	Ext. Throat	White	None	None	590x565x320	12	6.8	\$482.81
810201	Megaskim Concrete Ext/Thr Sq Lid	Concrete	Ext. Throat	White	Square	Tan	590x565x320	12	7.0	\$607.27
810202	Megaskim Concrete Ext/Thr Rnd Lid	Concrete	Ext. Throat	White	Round	Tan	590x565x320	12	7.0	\$607.27
810300	Skimmer Megaskim Conc Grey (No Lid)	Concrete	None	Grey	None	None	590x455x320	16	5.8	\$396.14
810301	Megaskim Grey Concrete Square Lid (Tan)	Concrete	None	Grey	Square	Tan	590x455x320	16	6.0	\$508.30
810302	Megaskim Grey Concrete Round Lid (Tan)	Concrete	None	Grey	Round	Tan	590x455x320	16	6.0	\$508.30
810303	Megaskim Grey Concrete Square Lid (Grey)	Concrete	None	Grey	Square	Grey	590x455x320	16	6.0	\$508.30
810304	Megaskim Grey Concrete Round Lid (Grey)	Concrete	None	Grey	Round	Grey	590x455x320	16	6.0	\$508.30



MegaSkim Skimmer

Skimmers for In-Ground Pools

WHITE GOODS & VALVES

FEATURES



Vacuum Plate with Flow Control



Massive 6.7L Leaf Basket



Widemouth Throat



Extensive Throat



Square and Round Child Safe Lids

FIBREGLASS POOL SKIMMERS

MPG17

Code	Description	Skimmer			Lid		Carton Dimensions (mm)	Carton Weight (kg)	Pallet Qty.	Price
		Pool	Extension	Colour	Shape	Colour				
810010	Megaskim F/Glass No Lid	Fibreglass	None	White	None	None	590x455x320	16	5.8	\$435.51
810011	Megaskim F/Glass Square Lid (Tan)	Fibreglass	None	White	Square	Tan	590x455x320	16	6.0	\$557.22
810012	Megaskim F/Glass Round Lid (Tan)	Fibreglass	None	White	Round	Tan	590x455x320	16	6.0	\$557.22
810110	Megaskim F/Glass W/ Mouth No Lid	Fibreglass	Widemouth	White	None	None	660x590x545	8	8.4	\$557.22
810111	Megaskim F/Glass W/ Mouth Square Lid	Fibreglass	Widemouth	White	Square	Tan	660x590x545	8	8.6	\$676.53
810112	Megaskim F/Glass W/ Mouth Round Lid	Fibreglass	Widemouth	White	Round	Tan	660x590x545	8	8.6	\$676.53
810210	Megaskim F/Glass Ext/ Throat No Lid	Fibreglass	Ext. Throat	White	None	None	590x565x320	12	6.8	\$530.97
810211	Megaskim F/Glass Ext/ Throat Square Lid	Fibreglass	Ext. Throat	White	Square	Tan	590x565x320	12	7.0	\$655.06
810212	Megaskim F/Glass Ext/ Throat Round Lid	Fibreglass	Ext. Throat	White	Round	Tan	590x565x320	12	7.0	\$655.06
810214	Megaskim F/G Ext. Throat Square Lid (Grey)	Fibreglass	Ext. Throat	White	Square	Grey	590x565x320	12	7.0	\$655.06
810215	Megaskim F/G Ext. Throat Round Lid (Grey)	Fibreglass	Ext. Throat	White	Round	Grey	590x565x320	12	7.0	\$655.06
810310	Grey Megaskim F/Glass No Lid	Fibreglass	None	Grey	None	None	590x455x320	16	5.8	\$435.51
810311	Grey Megaskim F/Glass Square Lid	Fibreglass	None	Grey	Square	Tan	590x455x320	16	6.0	\$557.22
810312	Grey Megaskim F/Glass Round Lid	Fibreglass	None	Grey	Round	Tan	590x455x320	16	6.0	\$557.22
810313	Grey Megaskim F/Glass Square Lid	Fibreglass	None	Grey	Square	Tan	590x455x320	16	6.0	\$557.22
810314	Grey Megaskim F/Glass Round Lid	Fibreglass	None	Grey	Round	Grey	590x455x320	16	6.0	\$557.22
810510	Skimmer Megaskim FG Ext. Throat Grey No Lid	Fibreglass	Ext. Throat	Grey	None	None	590x565x320	12	6.8	\$530.97
810511	Grey Megaskim F/G Ext. Throat Squarer Lid (Tan)	Fibreglass	Ext. Throat	Grey	Square	Tan	590x565x320	12	7.0	\$655.06
810512	Grey Megaskim F/G Ext. Throat Round Lid (Tan)	Fibreglass	Ext. Throat	Grey	Round	Tan	590x565x320	12	7.0	\$655.06
810513	Grey Megaskim F/G Ext. Throat Square Lid Grey	Fibreglass	Ext. Throat	Grey	Square	Grey	590x565x320	12	7.0	\$655.06
810514	Grey Megaskim F/G Ext. Throat Round Lid Grey	Fibreglass	Ext. Throat	Grey	Round	Grey	590x565x320	12	7.0	\$655.06

MegaSkim Skimmer

Skimmers for In-Ground Pools



DIMENSIONS

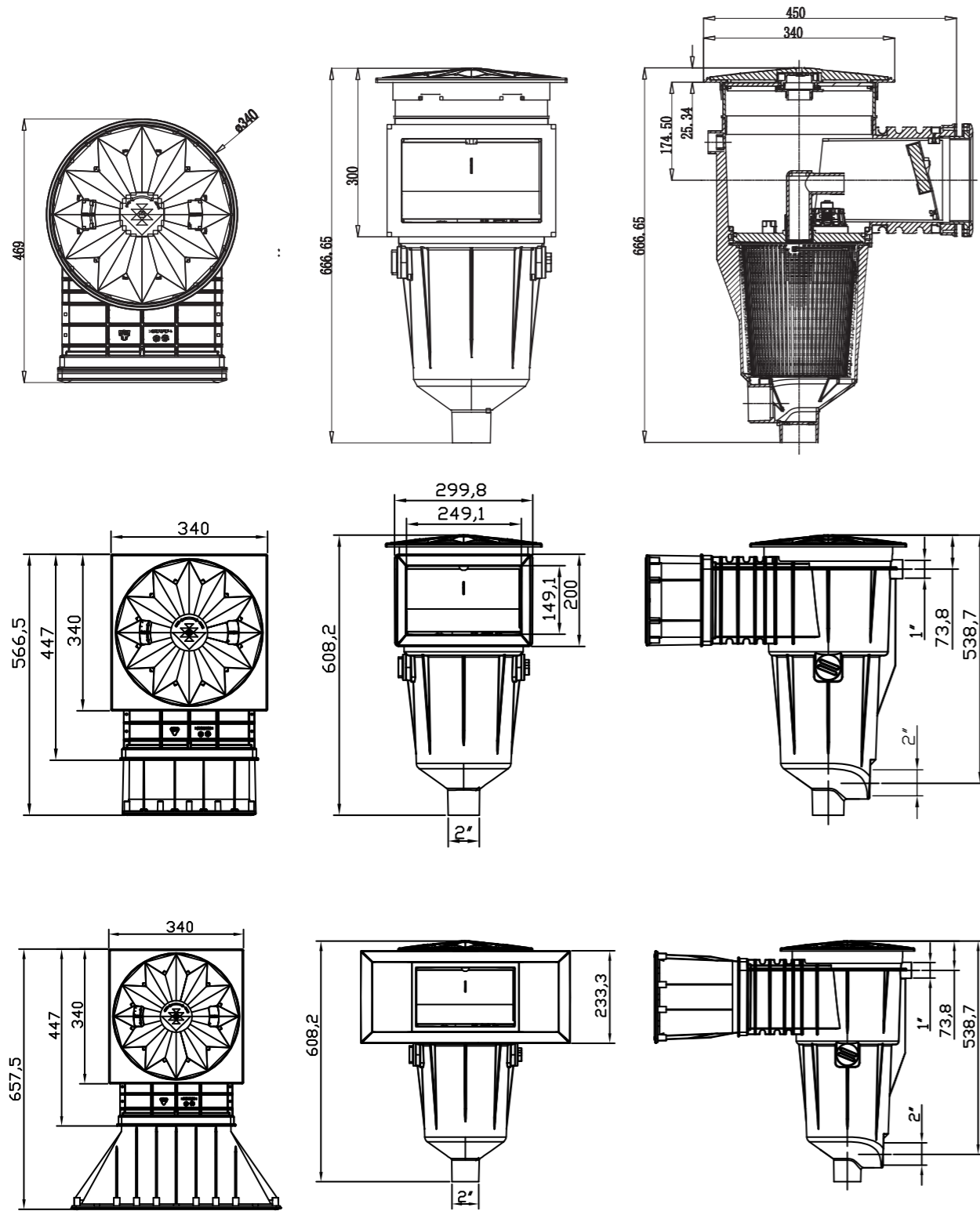

*All dimensions in mm



U-3 Skimmer

Skimmers for In-Ground Pools

FEATURES:

- Screw down lockable lid.
- 1-1/2"/40mm or 2"/50mm slip or threaded ports.
- Optional equalizer valve.
- Compliant to AS1926.3.

U-3 Skimmers feature a heavy-duty one-piece construction with sturdy external ribbing for superior strength. All U-3 Skimmers are made from high-strength ABS plastic.



DIMENSIONS

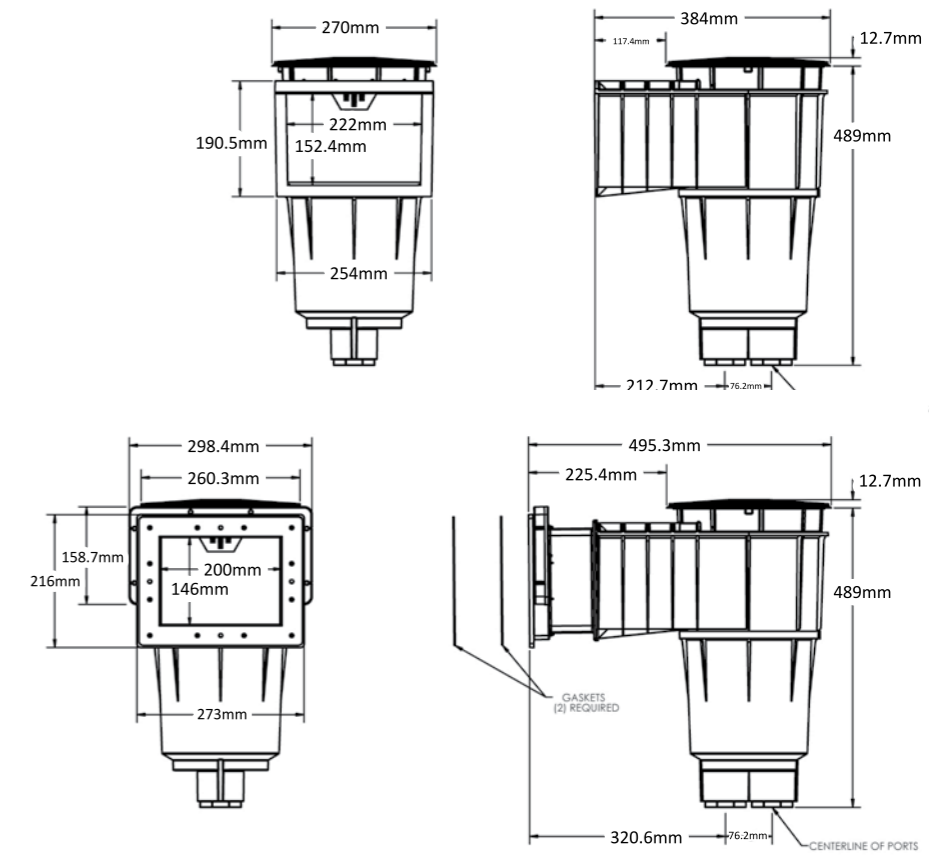

U-3 SKIMMERS

Codes	Description	Carton Dimensions (mm)	Carton Weight (kg)	Pallet Qty.	Price
MPG17					
FOR CONCRETE POOLS					
08650-1404	U-3 Skimmer White w/White Lid & Frame, 2 in. Slip with 1-1/2 in. Slip Reducers; Incl. Float and Check Valve, Basket 1	390x260x495	4	26	\$575.11
FOR VINYL POOLS					
09655-1404	Vinyl Skimmer – White; 2 in. Slip with 1-1/2 in. Slip Reducers	390x260x495	4	26	POA

*All dimensions in mm

StarGuard® Main Drains

Main Drain Frame and Grate



FEATURES:

- Screw down lockable lid.
- Compliant to AS1926.3, ANSI/ASME A112.19.8 and VGBA.
- 1 year Replacement Warranty.

High quality StarGuard main drains are available in a variety of configurations to fit most residential inground pool or spa installations. StarGuard main drains have an industry leading 100 square centimeters of open area for water flow and allow flow rates up to 270 LPM.

DIMENSIONS

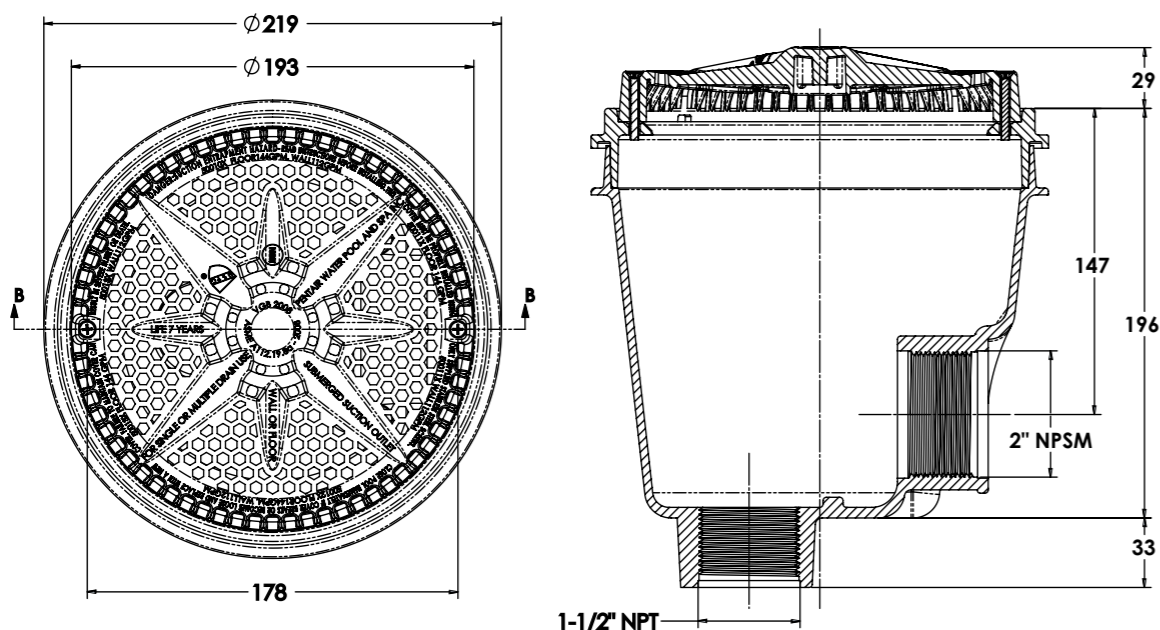

STARGUARD MAIN DRAINS

MPG17

Code	Description	Price
8 IN. STARGUARD COVER WITH SHORT RING AND COVER		
500103-1	8 in. StarGuard cover w/short ring (single), white	\$97.12
8 IN. STARGUARD DRAIN WITH 2 IN. SIDE AND 1-1/2 IN. BOTTOM PORTS ABS SUMP WITH RING AND COVER		
500110-1	8 in. StarGuard drain w/ 2 in. side & 1-1/2 in. bottom ports ABS sump w/ring & cover (2 pack), white	\$384.20
500113	8 in. StarGuard drain w/ 2 in. side & 1-1/2 in. bottom ports ABS sump w/ring & cover (2 pack), dark gray	\$384.20

*All dimensions in mm



ONGA Main Drain

Main Drain Frame, Grate and Hydrostatic Valve



FEATURES:

- Screw down lockable lid.
- Includes hydrostatic valve and pilot tube.
- Compliant to AS1926.3.
- 1 year Replacement Warranty.

High quality Onga main drains incorporate dual ports, hydrostatic relief valve and pilot tube. High quality construction and a proven performer for over a decade.

ONGA MAIN DRAIN

MPG17

Code	Description	Carton Dimensions (mm)	Carton Weight (kg)	Pallet Qty.	Price
1022000	Main Drain & Hydrostatic Relief Valve with Pilot Tube and Cover	310x310x240	1.4	64	\$331.70



Hydrostatic Valves

Niche, Great and Hydrostatic Valve

FEATURES:

- Screw down lockable lid.
- Compliant to AS1926.3.
- 1 year Replacement Warranty.

HYDROSTATIC VALVES

MPG17

Code	Description	Carton Dimensions (mm)	Carton Weight (kg)	Pallet Qty.	Price
HYDROSTATIC VALVES (NOT TO BE USED AS MAIN DRAINS)					
5317950	Small Drain & Hydrostatic Relief Valve with Pilot Tube and Cover for Concrete	210x200x190	0.8	150	\$146.76
5317955	Small Drain & Hydrostatic Relief Valve with Pilot Tube and Cover for F/Glass	210x200x190	0.8	150	\$208.42
5317900	Small Drain & Hydrostatic Relief Valve Only	210x200x190	0.7	150	\$88.18
HYDROSTATIC VALVE AND ONGA MAIN DRAIN ACCESSORIES					
5318000	Dress Ring & Cover for Small Drain/Hydrostatic - Concrete				\$47.97
5318100	Dress Ring & Cover for Small Drain/Hydrostatic - F/Glass				\$102.41
5132500	Hydrostatic Relief Valve Only 1 1/2" / 40mm				\$73.98
5163900	Pilot Tube for Drains				\$26.97
801016	Lid Main Drain				\$59.06
5163400	Hydrostatic Relief Valve Only 2" / 50mm				\$83.64

Pool Specialty Fittings

Return Fittings



SUCTION COVERS		MPG17
Code	Description	Price
CONCRETE SUCTION COVERS (NEW)		
800190	Suction Cover Concrete 50mm White	\$51.31
800190-20	Suction Cover Concrete 50mm White 20pk	\$770.80
800191	Suction Cover Concrete 50mm Grey	\$51.31
800191-20	Suction Cover Concrete 50mm Grey 20pk	\$770.80
800192	Suction Cover Concrete 50mm Clear	\$51.31
800192-20	Suction Cover Concrete 50mm Clear 20pk	\$770.80
FIBREGLASS SUCTION COVERS (NEW)		
800210	Suction Cover Fibreglass 50mm White	\$60.61
800210-20	Suction Cover Fibreglass 50mm White 20pk	\$908.01
800211	Suction Cover Fibreglass 50mm Grey	\$60.61
800211-20	Suction Cover Fibreglass 50mm Grey 20pk	\$908.01
800212	Suction Cover Fibreglass 50mm Clear	\$60.61
800212-20	Suction Cover Fibreglass 50mm Clear 20pk	\$908.01

EYEBALL RETURN FITTINGS		MPG17
Code	Description	Price
CONCRETE EYEBALL RETURNS		
800140	Eyeball Return Concrete 50mm White	\$15.87
800140-50	Eyeball Return Concrete 50mm White 50pk	\$640.74
800141	Eyeball Return Concrete 50mm Grey	\$15.87
800141-50	Eyeball Return Concrete 50mm Grey 50pk	\$640.74
800160	Eyeball Return Concrete 40mm White	\$15.87
800160-50	Eyeball Return Concrete 40mm White 50pk	\$640.74
800161	Eyeball Return Concrete 40mm Grey	\$15.87
800161-50	Eyeball Return Concrete 40mm Grey 50pk	\$640.74
FIBREGLASS EYEBALL RETURNS		
800077	Eyeball Return Fibreglass 40mm/1-1/2" White	\$21.48
800077-50	Eyeball Return Fibreglass 40mm White 50pk	\$746.93
800078	Eyeball Return Fibreglass 40mm/1-1/2" Grey	\$21.48
800078-50	Eyeball Return Fibreglass 40mm Grey 50pk	\$746.93
800079	Eyeball Return Fibreglass 40mm/1-1/2" Clear	\$21.48
800079-50	Eyeball Return Fibreglass 40mm Clear 50pk	\$746.93
OTHER EYEBALL RETURNS		
5115000	Eyeball Return Fibreglass 40mm (Quiptron)	\$37.35
5345000	Eyeball Return Vinyl 40mm (Quiptron)	\$62.16
5100000	Eyeball Return Concrete 40mm Slip (Quiptron)	\$16.59



Pool Specialty Fittings

Versatile Fitting System

WHITE GOODS & VALVES

STEP 1: SELECT WALL FITTING

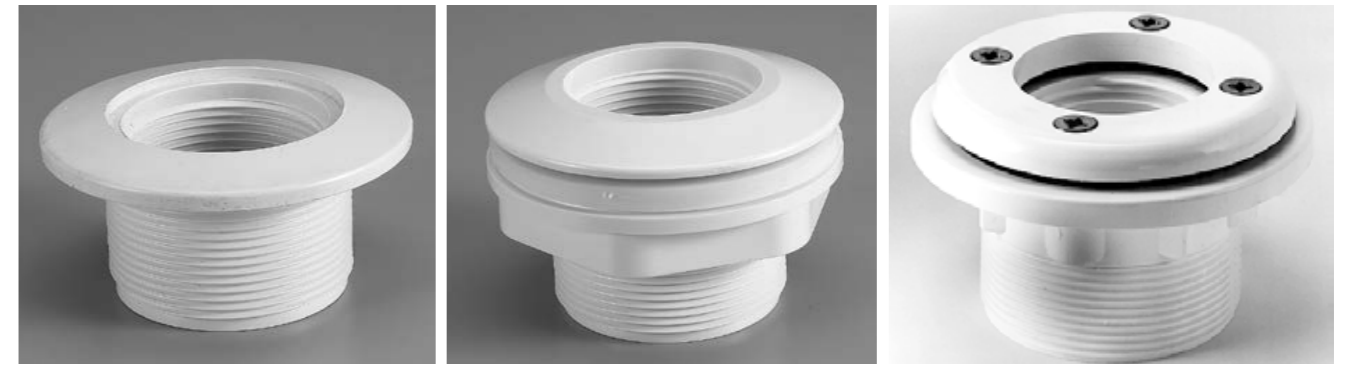

WALL FITTING			MPG17
Code	Description	Carton Qty	Price
WALL FITTINGS			
542405	CONCRETE Wall Fitting - 40mm Slip, 1-1/2" socket, white	50	\$19.57
542411	FIBREGLASS Wall Fitting - 40mm Slip, 1-1/2" socket, white	50	\$23.98
542429	CONCRETE/ VINYL LINER Wall Fitting - 40mm Slip, 1-1/2" socket, white	50	\$24.70

STEP 2: SELECT EYEBALLS



EYEBALLS			MPG17
Code	Description	Carton Qty	Price
EYEBALLS			
540000	Slotted Opening, white	50	\$9.07
540007	3/8" Opening, white	50	\$9.07
540014	1/2" Opening, white	50	\$9.07
540021	3/4" Opening, white	50	\$9.07
540028	1" Opening White	50	\$9.07

Pool Specialty Fittings

Inlets, Outlets & Unions



800408



829801 (09/10)



707634

FEATURES:

Pentair plumbing fittings are available in a wide variety of configurations. Specialty fittings such as the snap lock wall fitting are designed for ease of installation.

These fittings are manufactured to Pentair's high standards.

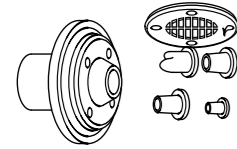

08429-0000



801953 / 801954



5115000



5345000



5100000



08417-0000



521511 / 521512



190058 / 190059



801950 / 801951



89280705 / 5166700



801964

POOL SPECIALTY FITTINGS

MPG17

Code	Description	Price
EYEBALL RETURN FITTINGS		
08429-0000	1-1/2in. Slip, 1/16 in., 3/4 in., 90° Nozzles, white	\$60.59
5115000	Eyeball 'Quipmaster'	\$37.35
5345000	Eyeball 40mm (F'Glass & Vinyl)	\$62.16
5100000	Eyeball Slip Fitting 40mm	\$16.59
INLETS		
08417-0000	Adjustable Floor Inlet White*	\$61.81
BARREL UNIONS		
800408	Self Aligning Barrel Union (40mm Internal / 50mm Slip)	\$44.86
707634	Barrel Union 40mm-40mm PVC (vinidex)	\$75.09
89280109	Barrell Union 1-1/2" BSP Thread to 40mm PVC	\$25.65
89280110	Barrell Union 2" BSP Thread to 50mm PVC	\$44.86
200-903	Barrell Union 2" NPT Thread to 50mm PVC	\$69.44
SADDLE CLAMPS		
521511	Saddle Clamp 40mm PVC - 1/2" NPT	\$86.74
521512	Saddle Clamp 50mm PVC - 1/2" NPT	\$86.74

MPG48

Code	Description	Price
PRESSURE GAUGES		
190059	0-60psi/0-4bar, Air Filled, Rear Mount, with clean filter dial	\$25.35
190058	0-60psi/0-4bar, Air Filled, Bottom Mount, with clean filter dial	\$23.70
89280705	0-270kPa, Oil Filled, Rear Mount	\$48.38
5166700	0-270kPa, Oil Filled, Bottom Mount	\$102.72
MPG27		
801950	Flow Meter 40mm 80-300LPM	\$329.32
801951	Flow Meter 50mm 120-500LPM	\$329.32
MPG27		
801953	Flow Switch 40mm Socket Fit	\$385.35
801954	Flow Switch 50mm Spigot Fit (requires 2x 50mm PVC F-F couplings)	\$409.34

Automatic Water Fillers

Water Level Control



Autofill Fluidmaster Water Fillers

FEATURES:

- Available for standard in-ground and vanishing edge pools.
- Prevents equipment damage due to low water levels.
- No electronic controls.
- Prevents water waste and landscape damage due to overfilling pool.
- Available with white, black, grey, and almond colored lids.

DIMENSIONS

Small Filler

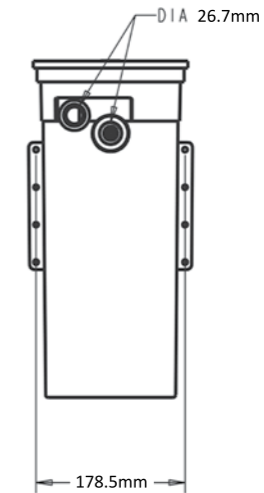
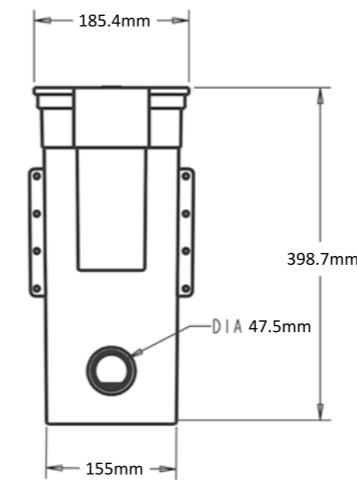

Fluidmaster Valve

AUTOMATIC WATER FILLERS

MPG17

Code	Description	Carton Dimensions (mm)	Carton Weight (kg)	Pallet Qty.	Price
FLUIDMASTER VALVE AUTOMATIC WATER FILLERS					
T40FW	AutoFill w/ Fluidmaster valve, white	420x210x210	1.8	50	\$436.70
T40FB	AutoFill w/ Fluidmaster valve, almond	420x210x210	1.8	50	\$436.70
T40FG	AutoFill w/ Fluidmaster valve, grey	420x210x210	1.8	50	\$436.70
T40FBK	AutoFill w/ Fluidmaster valve, black	420x210x210	1.8	50	\$436.70
STANDARD AUTOMATIC WATER FILLERS					
1023000	Onga Auto Refill Valve	310x310x240	2	36	\$436.70

*All dimensions in mm

See page 214 for replacement parts

Valves & Actuators

2-Way, 3-Way and Check



FEATURES:

- Maintenance-free PTFE coated diverter seal.
- Optimum positive-seal.
- High Flow Rate.
- Fibreglass reinforced handle.
- Withstands pressure up to 1MPa.
- Chemical-resistant.
- Used for diverting, shut-off or mixing applications.
- Accepts 40mm, 50mm and 65mm PVC plumbing.
- Field-adjustable stop positions.
- Plumbed with inlet at any port.
- Designed to work with most industry standard actuators.

VALVES

MPG17

Code	Description	Carton Dimensions (mm)	Carton Weight (kg)	Carton Qty.	Price
2-WAY AND 3-WAY DIVERTER VALVES					
263056	3-Way CPVC 65mm/2.5" (80mm/3" slip outside)	250x250x240	1.7	1	\$291.14
263059	2-Way CPVC 65mm/2.5" (80mm/3" slip outside)	250x250x240	1.7	1	\$281.59
263028	3-Way PVC 50mm/2" (65mm/2-1/2" slip outside)	600x400x400	6	12	\$105.12
263029	2-Way PVC 50mm/2" (65mm/2-1/2" slip outside)	600x400x400	6	12	\$95.93
263037	3-Way PVC 40mm/1-1/2" (50mm/2" slip outside)	600x400x400	6	12	\$87.94
263038	2-Way PVC 40mm/1-1/2" (50mm/2" slip outside)	600x400x400	6	12	\$78.63
263047	3-Way Solar Valve w/ drain-down, CPVC 2 in. (2-1/2 in. slip outside)	600x400x400	6	12	\$130.06
CHECK VALVES					
263060	Check Valve CPVC 65mm/2.5" (80mm/3" slip outside)	250x250x240	1.7	1	\$303.07
263042	Check Valve CPVC 50mm/2" (65mm/2-1/2" slip outside)	600x400x400	6	12	\$118.60
702480	Check Valve PVC 40mm/1-1/2" (50mm/2" slip outside)	600x400x400	6	12	\$74.57
PVC VALVES - BULK PACKS					
263028-12	Valve pvc 50mm 3-way 12 pack				\$1,002.27
263029-12	Valve pvc 50mm 2-way 12 pack				\$956.93
263037-12	Valve pvc 40mm 3-way 12 pack				\$814.94
263038-12	Valve pvc 40mm 2-way 12 pack				\$764.83
CHECK VALVES - BULK PACKS					
263042-12	Check valve pvc 50mm 12 pack				\$1,069.09
702480-12	Check valve pvc 40mm 12 pack				\$764.83

ACTUATORS

MPG16

VALVE ACTUATORS					
521485	IntelliValve Digital Valve Actuator				\$810.17
MPG17					
263045	Valve Actuator CVA-24T 180 Degree	400x300x300	8	8	\$462.95



POOL PVC FITTINGS

Pool PVC Fittings

POOL PVC FITTINGS

Code	Description
800.100PN6.6 SOE	PRES PIPE PN6 100MMx6M SOE
800.100PN9.6 SOE	PRES PIPE PN9 100MMx6M SOE
800.15PN15.6 SOE	PRES PIPE PN15 15MMx6M SOE
800.20PN15.6 SOE	PRES PIPE PN15 20MMx6M SOE
800.25PN15.6 SOE	PRES PIPE PN15 25MMx6M SOE
800.32PN12.6 SOE	PRES PIPE PN12 32MMx6M SOE
800.32PN15.6 SOE	PRES PIPE PN15 32MMx6M SOE
800.40PN12.6 SOE	PRES PIPE PN12 40MMx6M SOE
800.40PN15.6 SOE	PRES PIPE PN15 40MMx6M SOE
800.40PN6.6 SOE	PRES PIPE PN6 40MMx6M SOE
800.50PN12.6 SOE	PRES PIPE PN12 50MMx6M SOE
800.50PN15.6 SOE	PRES PIPE PN15 50MMx6M SOE
800.50PN6.6 SOE	PRES PIPE PN6 50MMx6M SOE
800.50PN9.6 SOE	PRES PIPE PN9 50MMx6M SOE
800.65PN12.6 SOE	PRES PIPE PN12 65MMx6M SOE
800.65PN15.6 SOE	PRES PIPE PN15 65MMx6M SOE
800.65PN6.6 SOE	PRES PIPE PN6 65MMx6M SOE
800.65PN9.6 SOE	PRES PIPE PN9 65MMx6M SOE
800.80PN12.6 SOE	PRES PIPE PN12 80MMx6M SOE
800.80PN15.6 SOE	PRES PIPE PN15 80MMx6M SOE
800.80PN6.6 SOE	PRES PIPE PN6 80MMx6M SOE
800.80PN9.6 SOE	PRES PIPE PN9 80MMx6M SOE
801.100.45	PRES ELBOW 100MMx45DEG
801.100.90	PRES ELBOW 100MMx90DEG
801.125.45	PRES ELBOW 125MMx45DEG PN16 GREY
801.125.90	PRES ELBOW 125MMx90DEG PN16 GREY
801.15.45	PRES ELBOW 15MMx45DEG
801.15.90	PRES ELBOW 15MMx90DEG
801.150.45	PRES ELBOW 150MMx45DEG
801.150.90	PRES ELBOW 150MMx90DEG
801.20.45	PRES ELBOW 20MMx45DEG
801.20.90	PRES ELBOW 20MMx90DEG
801.200.45	PRES ELBOW 200MMx45DEG PN10 GREY
801.200.90	PRES ELBOW 200MMx90DEG GREY
801.25.45	PRES ELBOW 25MMx45DEG
801.25.90	PRES ELBOW 25MMx90DEG
801.32.45	PRES ELBOW 32MMx45DEG
801.32.90	PRES ELBOW 32MMx90DEG
801.40.45	PRES ELBOW 40MMx45DEG

Pool PVC Fittings

POOL PVC FITTINGS

Code	Description
801.40.90	PRES ELBOW 40MMx90DEG
801.50.45	PRES ELBOW 50MMx45DEG
801.50.90	PRES ELBOW 50MMx90DEG
801.65.45	PRES ELBOW 65MMx45DEG PN16 DARK GREY
801.65.90	PRES ELBOW 65MMx90DEG
801.80.45	PRES ELBOW 80MMx45DEG
801.80.90	PRES ELBOW 80MMx90DEG
804.100	PRES TEE 100MM
804.125	PRES TEE 125MM PN16 GREY
804.15	PRES TEE 15MM
804.150	PRES TEE 150MM
804.20	PRES TEE 20MM
804.200	PRES TEE 200MM PN16 GREY
804.25	PRES TEE 25MM
804.32	PRES TEE 32MM
804.40	PRES TEE 40MM
804.50	PRES TEE 50MM
804.65	PRES TEE 65MM
804.80	PRES TEE 80MM
805.100.50	PRES RED TEE 100x50MM
805.20.15	PRES RED TEE 20x15MM
805.25.20	PRES RED TEE 25x20MM
805.32.25	PRES RED TEE 32x25MM
805.40.32	PRES RED TEE 40x32MM
805.50.40	PRES RED TEE 50x40MM
805.80.50	PRES RED TEE 80x50MM
806.100	PRES FAUCET COUPLER 100MM
806.15	PRES FAUCET COUPLER 15MM
806.20	PRES FAUCET COUPLER 20MM
806.25	PRES FAUCET COUPLER 25MM
806.32	PRES FAUCET COUPLER 32MM
806.40	PRES FAUCET COUPLER 40MM
806.50	PRES FAUCET COUPLER 50MM
806.65	65MM PN10 RATED PRESS FAUCET
806.80	PRES FAUCET COUPLER 80MM
807.15	PRES FAUCET TEE 15MM
807.20	PRES FAUCET TEE 20MM
807.25	PRES FAUCET TEE 25MM
808.15.90	PRES FAUCET ELBOW 15MMx90DEG

Pool PVC Fittings

POOL PVC FITTINGS

Code	Description
808.20.90	PRES FAUCET ELBOW 20MMx90DEG
808.25.90	PRES FAUCET ELBOW 25MMx90DEG
808.32.90	PRES FAUCET ELBOW 32MMx90DEG
809.15	PRES COMPRESSION COUP 15MM PN12
809.20	PRES COMPRESSION COUP 20MM PN12
809.25	PRES COMPRESSION COUP 25MM PN12
809.32	PRES COMPRESSION COUP 32MM PN12
809.40	PRES COMPRESSION COUP 40MM PN12
809.50	PRES COMPRESSION COUP 50MM PN12
810.100	PRES COUPLER 100MM
810.15	PRES COUPLER 15MM
810.150	PRES COUPLER 150MM
810.20	PRES COUPLER 20MM
810.25	PRES COUPLER 25MM
810.32	PRES COUPLER 32MM
810.40	PRES COUPLER 40MM
810.50	PRES COUPLER 50MM
810.65	PRES COUPLER 65MM
810.80	PRES COUPLER 80MM
811.15	PRES SKT UNION 15MM
811.20	PRES SKT UNION 20MM
811.25	PRES SKT UNION 25MM
811.32	PRES SKT UNION 32MM
811.40	PRES SKT UNION 40MM
811.50	PRES SKT UNION 50MM
813.100	PRES VALVE SKT 100MM
813.15	PRES VALVE SKT 15MM
813.20	PRES VALVE SKT 20MM
813.25	PRES VALVE SKT 25MM
813.32	PRES VALVE SKT 32MM
813.40	PRES VALVE SKT 40MM
813.50	PRES VALVE SKT 50MM
813.65	PRES VALVE SKT 65MM
813.80	PRES VALVE SKT 80MM
817.15	PRES VALVE SPIGOT 15MM
817.20	PRES VALVE SPIGOT 20MM
817.25	PRES VALVE SPIGOT 25MM
817.32	PRES VALVE SPIGOT 32MM
817.40	PRES VALVE SPIGOT 40MM

Pool PVC Fittings

POOL PVC FITTINGS

Code	Description
817.50	PRES VALVE SPIGOT 50MM
818.20.15	PRES THREADED BUSH 20x15MM
818.25.20	PRES THREADED BUSH 25x20MM
823.100.80	PRES REDUCING SKT 100x80MM
823.125.100	PRES REDUCING SKT 125x100MM
823.150.100	PRES REDUCING SKT 150x100MM
823.20.15	PRES REDUCING SKT 20x15MM
823.25.20	PRES REDUCING SKT 25x20MM
823.32.25	PRES REDUCING SKT 32x25MM
823.40.32	PRES REDUCING SKT 40x32MM
823.50.40	PRES REDUCING SKT 50x40MM
823.65.50	PRES REDUCING SKT 65x50MM
823.80.50	PRES REDUCING SKT 80x50MM
823.80.65	PRES REDUCING SKT 80x65MM
824.100.50	PRES RED BUSH 100x50MM
824.100.80	PRES RED BUSH 100x80MM
824.150.100	PRES RED BUSH 150x100MM
824.150.125	PRES RED BUSH 150x125MM PN16 GREY
824.20.15	PRES RED BUSH 20x15MM
824.25.15	PRES RED BUSH 25x15MM
824.25.20	PRES RED BUSH 25x20MM
824.32.25	PRES RED BUSH 32x25MM
824.40.25	PRES RED BUSH 40x25MM
824.40.32	PRES RED BUSH 40x32MM
824.50.40	PRES RED BUSH 50x40MM
824.65.50	PRES RED BUSH 65x50MM
824.80.50	PRES RED BUSH 80x50MM
824.80.65	PRES RED BUSH 80x65MM GREY
825.100	PRES F/F FLANGE 100MM
825.150	PRES F/F FLANGE 150MM
825.50	PRES F/F FLANGE 50MM
825.65	PRES F/F FLANGE 65MM
825.80	PRES F/F FLANGE 80MM
826.100	PRES STUB FLANGE 100MM
826.125	PRES STUB FLANGE 125MM PN16 GREY
826.150	PRES STUB FLANGE 150MM
826.175	PRES STUB FLANGE 175MM PN10 GREY
826.200	PRES STUB FLANGE 200MM PN10 GREY
826.225	PRES STUB FLANGE 225MM PN10 GREY

Pool PVC Fittings

POOL PVC FITTINGS

Code	Description
826.300	PRES STUB FLANGE 300MM PN10 GREY
826.50	PRES STUB FLANGE 50MM PN16 GREY
826.65	PRES STUB FLANGE 63MM
826.80	PRES STUB FLANGE 80MM
827.100	PRES METAL BACKING RING 100MM
827.125	PRES METAL BACKING RING 125MM
827.150	PRES METAL BACKING RING 150MM
827.200	PRES METAL BACKING RING 200MM
827.300	PRES METAL BACKING RING 300MM
827.50	PRES METAL BACKING RING 50MM
827.65	PRES METAL BACKING RING 65MM
827.80	PRES METAL BACKING RING 80MM
830.100	PRES END CAP 100MM
830.125	PRES END CAP 125MM
830.15	PRES END CAP 15MM
830.150	PRES END CAP 150MM
830.20	PRES END CAP 20MM
830.25	PRES END CAP 25MM
830.32	PRES END CAP 32MM
830.40	PRES END CAP 40MM
830.50	PRES END CAP 50MM
830.65	PRES END CAP 65MM
830.80	PRES END CAP 80MM
837.100	PRES END PLUG THRD 100MM
837.15	PRES END PLUG THRD 15MM
837.20	PRES END PLUG THRD 20MM
837.25	PRES END PLUG THRD 25MM
837.32	PRES END PLUG THRD 32MM
837.40	PRES END PLUG THRD 40MM
837.50	PRES END PLUG THRD 50MM
837.80	PRES END PLUG THRD 80MM
840.15	PRES PIPE SADDLE CLIP 15MM
840.20	PRES PIPE SADDLE CLIP 20MM
840.25	PRES PIPE CLIP 25MM
840.32	PRES PIPE CLIP 32MM
840.40	PRES PIPE CLIP 40MM
840.50	PRES PIPE CLIP 50MM



**MAINTENANCE
EQUIPMENT**

Value Range

Pool Maintenance Equipment



FEATURES:

- Available with Nylon or Stainless Steel bristles.
- High quality, chemical resistant plastics.
- Tough hard-wearing bristles.
- Australian-style handle..



Rainbow Range

Professional Premium Quality Maintenance Equipment

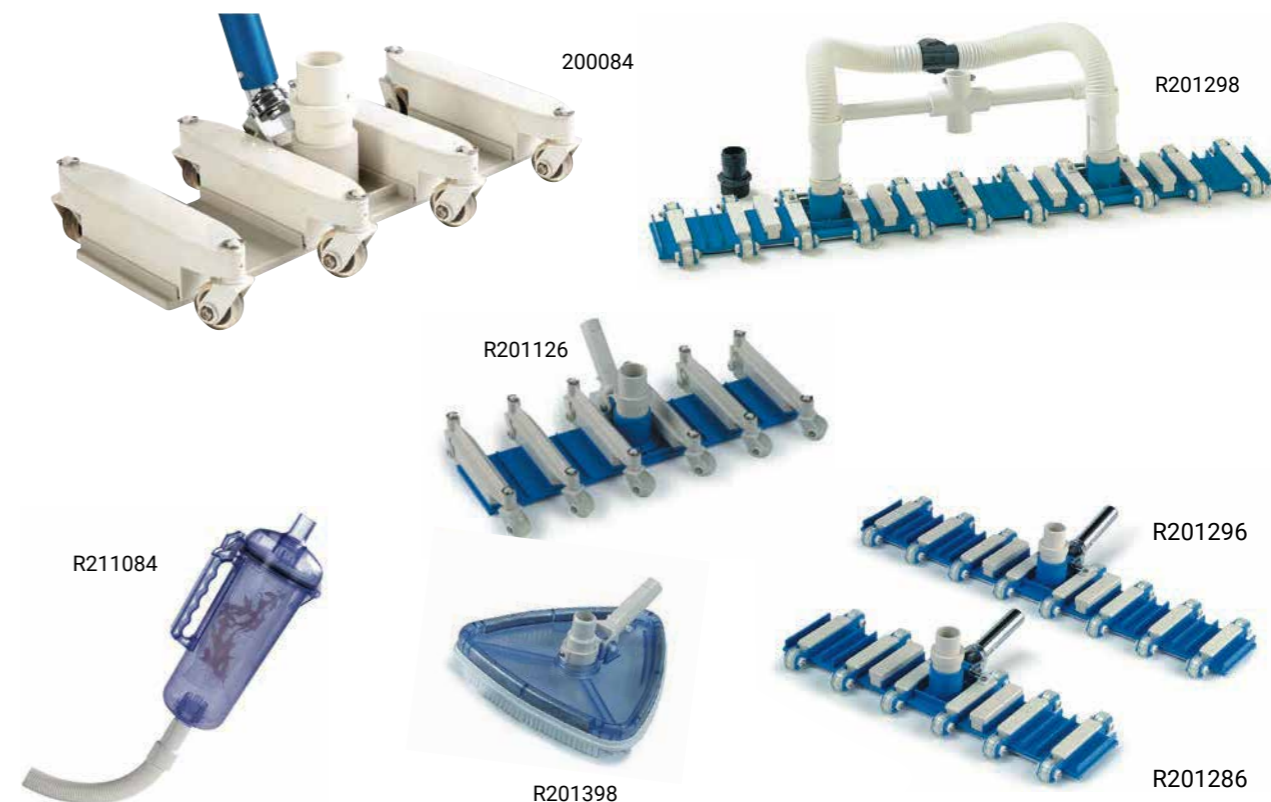

POOL MAINTENANCE EQUIPMENT

POOL MAINTENANCE EQUIPMENT						MPG26
Code	Description	Handle Type	Carton Dimensions (mm)	Carton Weight (kg)	Carton Qty.	Price
BRUSHES						
K038BU	Brush 45cm (18") Cyclocac Nylon Bristles	Australian	510x320x340	4.3	12	POA
5169550	Brush 25cm (10") Stainless Steel Bristles	Australian	300x300x270	5	12	POA
RAKES AND SKIMMERS						
5190450	Deluxe Deep Leaf Rake	Australian	440x420x530	8	12	POA
5169450	Deluxe Leaf Skimmer	Australian	550x440x410	7	12	POA
VACUUM HEADS						
5164050	Vacuum Head Fibreglass/Vinyl Contour Shaped	Australian	360x300x290	8.5	12	POA
5157550	Vacuum Head Concrete 35cm(14") Flexible	Australian	390x350x320	18.2	2	POA
R211036	Venturi Vacuum Leaf Eater with Wheels and Brush	Universal	775x395x400	6.3	6	POA
TELESCOPIC POLES						
90697	Pole Telescopic Aluminium 2.4m-4.8m	Australian	2620x160x130	13.5	12	POA

POOL MAINTENANCE EQUIPMENT

POOL MAINTENANCE EQUIPMENT						MPG26
Code	Description	Handle Type	Carton Dimensions (mm)	Carton Weight (kg)	Carton Qty.	Price
LEAF TRAPS						
R211084	Leaf Trap 1-1/2" for 38mm Hose	-	527x279x190	16.5	6	POA
BROOMS & BRUSHES						
R111626	Brush 23cm(9") Aluminium Back SS Bristles	Universal				POA
R111646	Brush 45cm(18") Aluminium Back SS Bristles	Universal				POA
R111046	Brush 45cm(18") Aluminium Back Nylon Bristles	Universal				POA
R111358	Brush 45cm(18") Aluminium Back SS/Nylon Bristles	Universal				POA
RAKES AND SKIMMERS						
R121196	Skimmer Heavy Duty Aluminium Frame	Universal	-	-	-	POA
R121230	Leaf Rake Heavy Duty Aluminium Frame Fibreglass Net	Universal	-	-	-	POA
VACUUM HEADS						
R201398	Vacuum Head Triangular Clear Vlew Swivel Hose	Universal	Call	13.5	6	POA
R201286	Pro Vac 55cm(22") Chrome Swivel Handle 8 Weights	Universal	Call	4.8	1	POA
R201296	Pro Vac 73cm(29") Chrome Swivel Handle 10 Weights	Universal	Call	5.5	1	POA
R201126	Swivel Wheel Vacuum Head 48cm (19")	Universal	Call	18.5	4	POA
R201298	Super Pro Vac 106cm(41")	Universal	Call	10.5	1	POA
200084	Provac II	Universal	Call	10.5	1	POA

Miscellaneous Parts

Pool Maintenance Equipment



Handover Kit

Pool Maintenance Equipment



FEATURES:

- Vacuum head.
- 450mm Deluxe brush.
- Leaf Rake.
- Thermometer.
- 5-Way Test Strips.
- CPR chart.
- Choice between 9, 11 or 15m Vacuum hose.
- 2.4 – 4.8m Telescopic Pole

POOL MAINTENANCE EQUIPMENT

MPG26

Code	Description	Carton Dimensions (mm)	Carton Weight (kg)	Carton Qty.	Price
THERMOMETERS					
K080CS	Jim Bouy Thermometer	270x230x280	2.5	12	POA
K084BL	Deluxe Floating Thermometer	360x300x260	2.5	12	POA
TEST KITS					
R161568	Test Strips 5-Way Cl-/Br - TCl - pH - TA - TH		1.5	12	POA
200060	Test Strips Salt		12.0	12	POA
AQ1014	DPD Test Kit 2 in 1		5.0	24	POA
AQ1029	DPD Test Kit 4 in 1		8.0	12	POA
R151226	Cyanuric Acid Test Kit		0.5	1	POA
R151716	PROII Professional Test Lab		6.5	6	POA
TEST SOLUTION REFILLS					
R161593	DPD#1 Tablets 50pk		1.0	12	POA
FLOATING DISPENSERS					
R141106	Deluxe Floating Thermometer with String				POA
R171060	Large Round Pop-Up Floating Dispenser 8" (5x 3" Tablets)	660x450x310	5	12	POA
EXTRAS					
K039BL	Universal Quick Snap Butterfly Clips (3 Pack)	230x200x240	4.3	50	POA
K116BU	Australian Pole Butterfly Clip	490x320x300	1.5	50	POA
K098BU	Australian Replacement Handle	450x300x320	10.5	144	POA
K079BL	Tripple Hook Heavy Duty Hangers (2 Pack)	510x430x220	2.2	12	POA

POOL MAINTENANCE EQUIPMENT

MPG26

Code	Description	Hose Length (m)	Pallet Qty.	Pole	Price
CONCRETE INGROUND POOL HANDOVER KITS					
HOKIT-CON-9M-5W	Handover kit concrete no pole	9	24	Excluded	\$340.06
HOKIT-CON-11M-5W	Handover kit concrete no pole	11	24	Excluded	\$359.15
HOKIT-CON-15M-5W	Handover kit concrete no pole	15	24	Excluded	\$379.43
HOKIT-CON-9M	Handover kit concrete with telescopic pole	9	24	Included	\$415.23
HOKIT-CON-11M	Handover kit concrete with telescopic pole	11	24	Included	\$435.51
HOKIT-CON-15M	Handover kit concrete with telescopic pole	15	24	Included	\$451.02
FIBREGLASS / VINYL POOL HANDOVER KITS					
HOKIT-FG-11M-5W	Handover kit fibreglass no pole	11	24	Excluded	\$359.15
HOKIT-FG-11M	Handover kit fibreglass with telescopic pole	11	24	Included	\$435.51

Starline ISO

End Suction Centrifugal Pumps



Starline ISO

End Suction Centrifugal Pumps



FEATURES:

- Compact close coupled design.
- Superior hydraulic design and manufacturing methods for significantly higher efficiencies and reduced maintenance.
- High efficiency double curvature impeller vanes.
- 50 to 200mm discharge.
- Cast iron or stainless steel construction.
- AS2129 Table "E" flanges as standard with optional drillings available.
- Back-pullout design does not require the disconnection and removal of suction and discharge lines for maintenance.
- Choice of high quality WEG TEFC IP55 motors with sealed for life (11kW and under) or regreasable (15kW and over) motor bearings.
- Taper mounted and keyed impeller.
- Horizontal or vertical pump discharge mounting.



The Southern Cross ISO end suction pumps are non- self priming, single stage, centrifugal volute pumps with axial suction port, radial discharge port and horizontal shaft.

Starline ISO pumps are suitable for all applications in commercial pool.

Below table and charts feature all stainless steel pumps with 1450RPM motors.

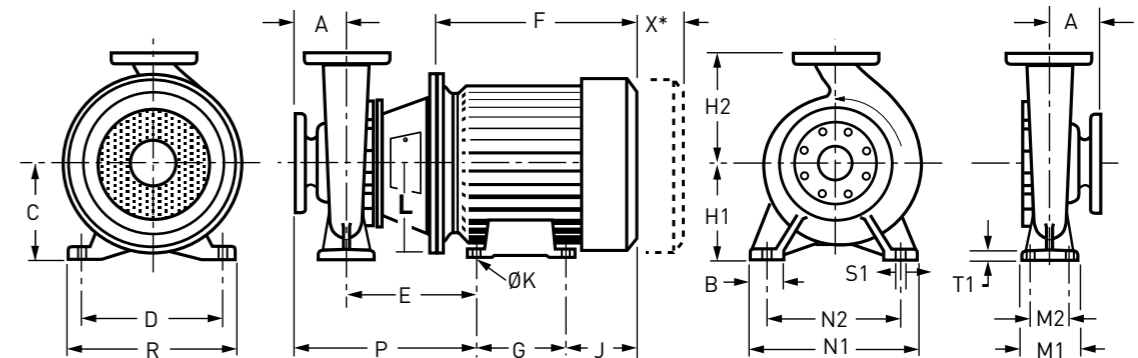
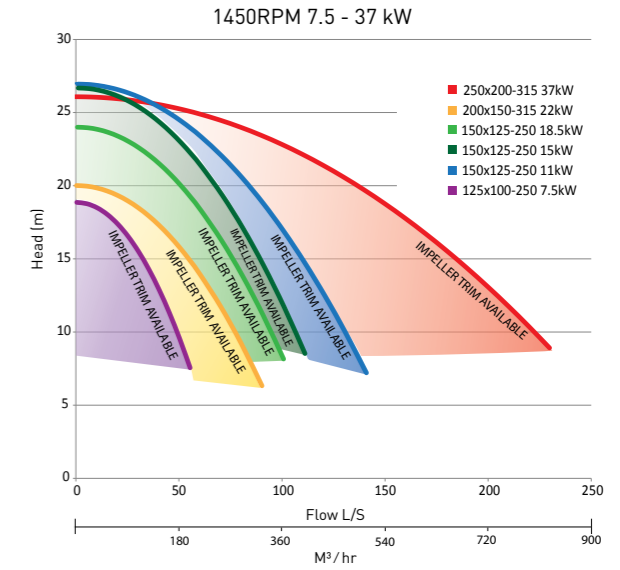
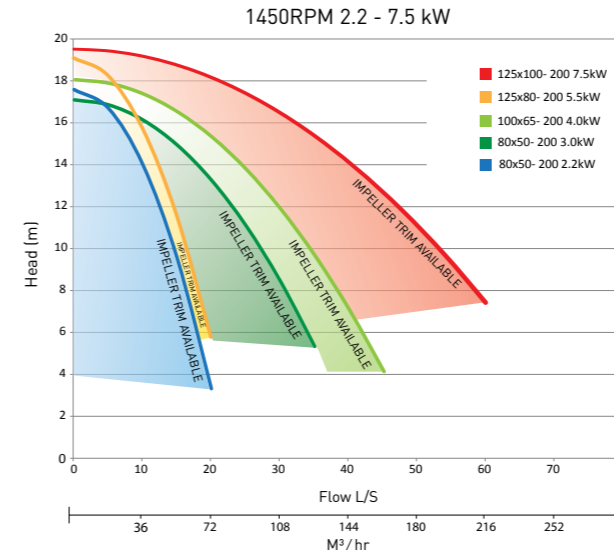

STARLINE ISO

Code	Model	Motor Power Rating (kw)	RPM	Voltage (VAC)	Input Power (P1, kW)	Output Power (P2, kW)	Max Current (A)	Price
STARLINE ISO								
MUFC45S	80X50-200	2.2	1450	400-415	2.54	2.2	4.5	POA
MUFC46S	80X50-200	3	1450	400-415	2.91	2.55	5	POA
MUFD47S	100X65-200	4	1450	400-415	4.51	4	7.8	POA
MUFE48S	125X80-200	5.5	1450	400-415	6.17	5.5	10.2	POA
MUFF49S	125X100-200	7.5	1450	400-415	8.25	7.47	13.5	POA
MUGF49S	125x100-250	7.5	1450	400-415	8.29	7.5	13.6	POA
MUGG51S	150x125-250	11	1450	400-415	12.05	11	20.7	POA
MUGG52S	150x125-250	15	1450	400-415	16.34	15	28.1	POA
MUGG53S	150x125-250	18.5	1450	400-415	19.81	18.5	34.4	POA
MUHH54S	200x150-315	22	1450	400-415	23.48	22	38.4	POA
MUHH55S	200x150-315	30	1450	400-415	31.98	30	54.9	POA
MUHJ57S	250x200-315	37	1450	400-415	39.53	37	63.7	POA

Pump Model	80X50-200 2.2KW	80X50-200 3KW	100X65-200 4KW	125X80-200 5.5KW	125X100-200 7.5KW	125X100-250 7.5KW	150X125-250 11KW	150X125-250 15KW	150X125-250 18.5KW	200X150-315 22KW	200X150-315 30KW	250X200-315 37KW
A (mm)	100	100	100	125	125	140	140	140	140	160	160	180
B (mm)	50	50	65	65	80	80	80	80	80	100	100	100
C (mm)	100	100	100	132	132	132	160	160	180	180	200	225
D (mm)	160	160	160	216	216	216	254	254	279	279	318	356
E (mm)	225	225	229	274	275	295	349	349	362	461	473	489
F (mm)	325	325	325	390	430	430	505	560	575	615	643	660
G (mm)	140	140	140	140	178	178	210	254	241	279	305	286
H1 (mm)	160	160	180	180	200	225	250	250	250	315	315	315
H2 (mm)	200	200	225	250	280	280	355	355	355	400	400	450
J (mm)	122	122	122	161	163	163	187	198	213	215	205	225
K (mm)	12	12	12	12	12	12	15	15	15	15	19	19
L (mm)	125	125	125	150	150	150	175	175	175	175	200	225
M1 (mm)	100	100	125	125	160	160	160	160	160	210	210	210
M2 (mm)	70	70	95	95	120	120	120	120	120	150	150	150
N1 (mm)	265	265	320	345	360	400	400	400	400	540	540	540
N2 (mm)	212	212	250	280	280	315	315	315	315	450	450	450
P (mm)	325	325	329	399	400	435	489	489	502	621	633	669
R (mm)	205	205	205	270	270	270	320	320	355	355	395	435
ST1 (mm)	14	14	14	14	18	18	18	18	18	22	22	22
T1 (mm)	13	13	15	16	17	18	19	19	19	20	20	25
GAP X (mm)	100	100	140	140	140	140	140	140	140	180	180	180
Weight (kg)	80	84	92	132	151	177	241	262	300	463	543	597

*All models available with impeller trims to match best efficiency point with duty point. Contact Pentair for optional engineered solutions.

**Pump model consists of suction size X discharge size - nominal impeller diameter.

*Terms and conditions apply

5PSP Series

Commercial High Performance Pool Pumps



5PSP Series

Commercial High Performance Pool Pumps



FEATURES:

- New improved design and additional 12.5Hp model.
- Especially designed for swimming pool, aquatic and aquaculture applications.
- Seawater approved up to 4% salt concentration.
- Large pre-filter.
- Injection molded components of high quality glass reinforced thermoplastic.
- CE & TUV Approved, IP55 protected, IE2 compliant TEFC motor.
- Corrosion resistant, high grade stainless steel motor shaft.
- Metric and imperial connections available.
- High chemical resistance with all metal internal components being stainless steel.
- 4"/100mm suction, 3"/80mm discharge (4"/100mm discharge on 7.5, 10 and 12hp).
- 1 year commercial warranty.*

PENTAIR Thermoplastic Centrifugal Pumps are self priming, single stage, close-coupled (Pump with built-in electric motor, with the motor drive and pump impeller on the same shaft), monoblock centrifugal pumps with closed impeller and mechanical seals.

These pumps are suitable for non-aggressive, nonexplosive, clean or slightly contaminated liquids with low viscosity and specially designed for the pre-filtering and re-circulation of water in swimming pools, fish farming and other general purposes.

DIMENSIONS AND PERFORMANCE*

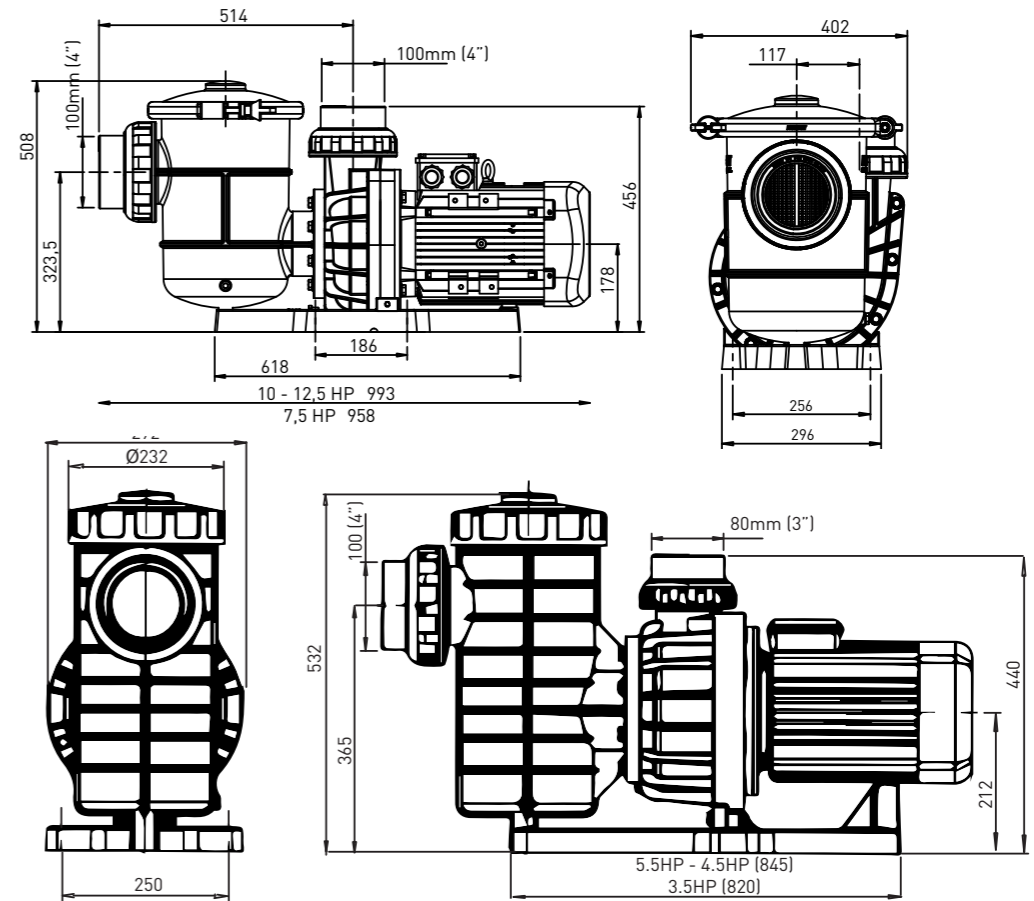
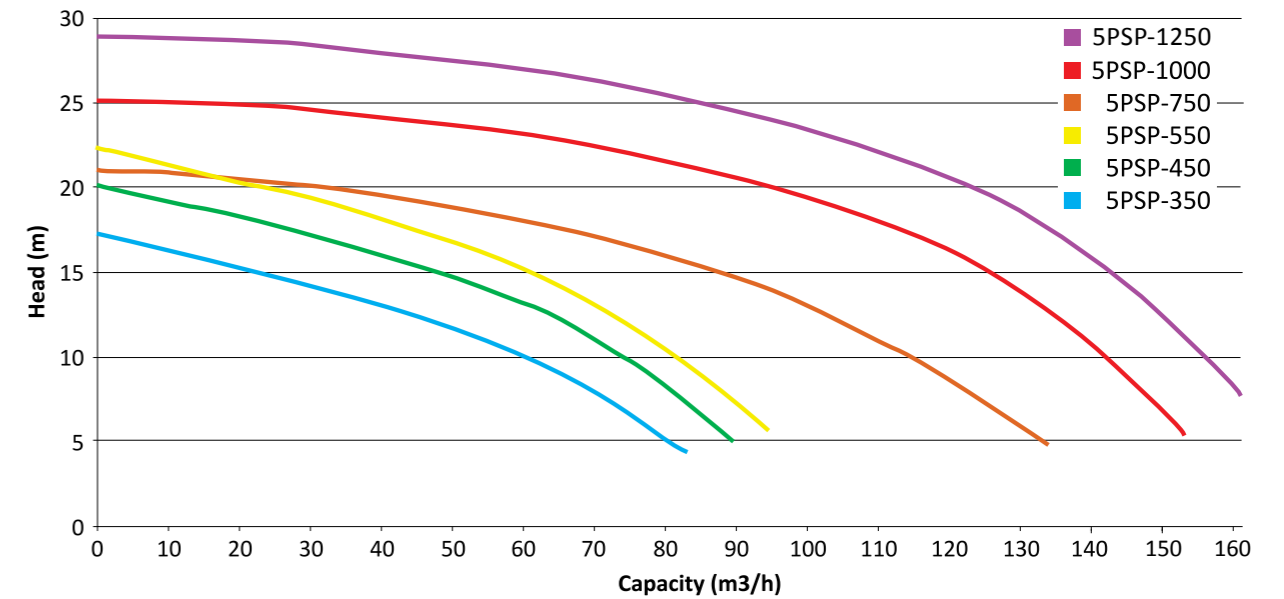

5PSP SERIES

MPG24

Code	Model	Voltage (VAC)	Max Phase Current (A)	Nominal Power (hp)	Input Power (P ¹ , kW)	Output Power (P ² , kW)	Carton Dimensions (mm)	Carton Weight (Kg)	Price
3-PHASE Y CONFIGURATION WITH PRE-FILTER									
5PSP-350-3U	5PSP 3.5hp With Strainer	400-415	7.1	3.5	2.68	2.27	860x375x600	30	\$8,289.63
5PSP-450-3U	5PSP 4.5hp With Strainer	400-415	9.7	4.5	3.66	3.14	860x375x600	41	\$7,835.66
5PSP-550-3U	5PSP 5.5hp With Strainer	400-415	11.2	5.5	4.28	3.67	860x375x600	41	\$8,081.62
3-PHASE Y/DELTA CONFIGURATION WITH PRE-FILTER									
5PSP-750-3U	5PSP 7.5hp With Strainer	400-415	17.6	7.5	6.71	5.90	960x450x770	84	\$10,090.56
5PSP-1000-3U	5PSP 10hp With Strainer	400-415	22.7	10	8.65	7.65	960x450x770	90	\$11,375.37
5PSP-1250-3V2U	5PSP 12.5hp With Strainer	400-415	28.5	12.5	11.25	10.0	960x450x770	94	\$13,873.19

*Terms and conditions apply.

*All dimensions in mm.
See pages 143, 145 for replacement parts.

PWT-V Commercial Filter

Fibreglass Tank with Top Mount MPV



FEATURES:

- Spun-woven, UV resistant fibreglass construction for exceptional strength, chemical resistance and long life.
- Max Operating Pressure 250kPa.
- Dual layers of Laterals.
- Hybrid 65mm/2.5" MPV with 80mm/3" barrel unions.
- 5 year commercial warranty (pro-rata).*

The Pentair V Series satisfies the demand of different water treatment including pools installed with in-floor cleaning systems, spas, fountains and public swimming pools. The bobbin-wound fibreglass reinforced tank is the most popular standard in the industry. UV resistant and equipped with a six-position multi-port valve.

DIMENSIONS

Model	A (mm)	B (mm)	C (mm)	D (mm)
PWT-V-09-50	1300	900	1172	1090
PWT-V-10-80	1434	1000	1410	1160
PWT-V-12-80	1634	1200	1620	1368

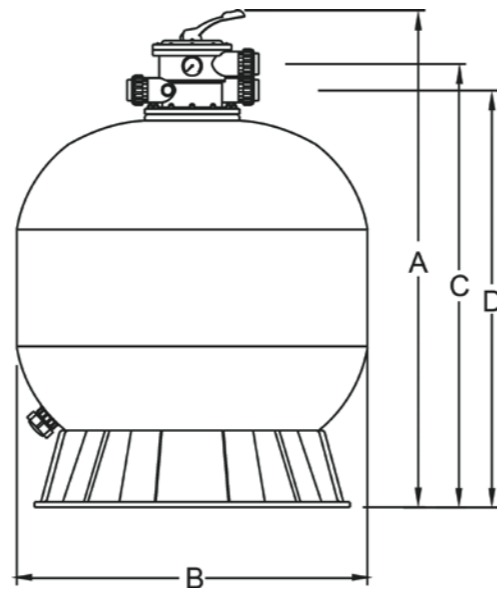

PWT-V TOP MOUNT MPV FILTERS

MPG24

Code	Product	Effective Filter Area (m ²)	Valve Conn. (in.)	Maximum Flow Rate (m ³ /hr)	Backwash Flow Rate (m ³ /hr)	Sand Required (kg)	Gross Weight (kg)	Price
PWT-V TOP MOUNT MPV FILTERS								
PWT-V-09-50	Vertical Filter Top-Mount Filter 0.9m dia. with MPV	0.64	2"/50mm	31.2	22.4	470	90	POA
PWT-V-10-80	Vertical Filter Top-Mount Filter 1.0m dia. with MPV	0.79	3"/80mm	39.5	27.6	620	102	POA
PWT-V-12-80	Vertical Filter Top-Mount Filter 1.2m dia. with MPV	1.13	3"/80mm	56.5	39.5	860	114	POA

*Terms and conditions apply



PWT-S Commercial Filter

Fibreglass Tank with Side Mount MPV



FEATURES:

- Spun-woven, UV resistant fibreglass construction for exceptional strength, chemical resistance and long life.
- Max Operating Pressure 250kPa.
- Dual layers of Laterals.
- 2.5" (65mm) Barrel union connections.
- 1 year commercial warranty.*

The Pentair S Series satisfies the demand of different water treatment including pools installed with in-floor cleaning systems, spas, fountains and public swimming pools. The bobbin-wound fibreglass reinforced tank is the most popular standard in the industry. UV resistant and equipped with a six-position multi-port valve.

DIMENSIONS

Model	A (mm)	B (mm)	C (mm)	D (mm)	E (mm)	F (mm)
PWT-S-10-30	773	844	1220	480	1020	780
PWT-S-12-30	836	1079	1410	640	1220	1000

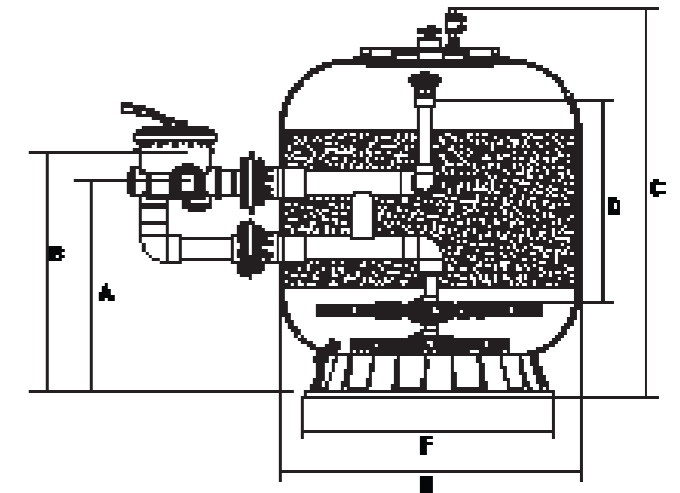

PWT-S SIDE MOUNT MVP FILTERS

MPG24

Code	Product	Effective Filter Area (m ²)	Valve Conn. (in.)	Maximum Flow Rate (m ³ /hr)	Sand Required (kg)	Gross Weight (kg)	Price
PWT-S SIDE MOUNT MVP FILTERS							
PWT-S-10-30	Side-Mount Filter 1.0m dia. 80mm MPV	0.82	3" / 80mm	41	620	102	POA
PWT-S-12-30	Side-Mount Filter 1.2m dia. 80mm MPV	1.17	3" / 80mm	59	860	114	POA

*All dimensions in mm.

PWT-SDB Commercial Filter

Deep Bed Fibreglass Tank with Side-Mount Multiport Valve



FEATURES:

- Spun-woven, UV resistant fibreglass construction for exceptional strength, chemical resistance and long life.
- Max Operating Pressure 250kPa.
- Dual layers of Laterals.
- 4" Sight Glass.
- Manhole for servicing.
- 50mm / 2" Drain.
- 1 year commercial warranty.*

The Pentair Deep Bed Filters offer a more thorough filtration with a standard 1.0m or 1.2m deep sand bed. Giving high filtration performance for large domestic and commercial swimming pools.



PWT-SDB COMMERCIAL FILTER

								MPG24
Code	Product	Effective Filter Area (m ²)	Valve Conn. (in.)	Maximum Flow Rate (m ³ /hr)	Backwash Flow Rate (LPM)	Sand Required (kg)	Carton Weight (kg)	Price
SIDE-MOUNT DEEP BED FILTERS 1M SAND BED								
PWT-SDB-10-07-20	Side-Mount Deep Bed Filter - 0.7m dia \ 1m Sand Bed \ 2" Vlv	0.38	2"	253	205	580	135	POA
PWT-SDB-10-08-20	Side-Mount Deep Bed Filter - 0.8m dia \ 1m Sand Bed \ 2" Vlv	0.5	2"	333	270	769	170	POA
PWT-SDB-10-09-20	Side-Mount Deep Bed Filter - 0.9m dia \ 1m Sand Bed \ 2" Vlv	0.63	2"	420	340	957	240	POA
PWT-SDB-10-09-25	Side-Mount Deep Bed Filter - 0.9m dia \ 1m Sand Bed \ 2.5" Vlv	0.63	2.5"	525	340	957	240	POA
PWT-SDB-10-10-20	Side-Mount Deep Bed Filter - 1.0m dia \ 1m Sand Bed \ 2" Vlv	0.78	2"	520	420	1204	290	POA
PWT-SDB-10-10-25	Side-Mount Deep Bed Filter - 1.0m dia \ 1m Sand Bed \ 2.5" Vlv	0.78	2.5"	650	420	1204	290	POA
SIDE-MOUNT DEEP BED FILTERS 1.2M SAND BED								
PWT-SDB-12-07-20	Side-Mount Deep Bed Filter - 0.7m dia \ 1.2m Sand Bed \ 2" Vlv	0.38	2"	253	205	696	150	POA
PWT-SDB-12-08-20	Side-Mount Deep Bed Filter - 0.8m dia \ 1.2m Sand Bed \ 2" Vlv	0.5	2"	333	270	914	188	POA
PWT-SDB-12-09-20	Side-Mount Deep Bed Filter - 0.9m dia \ 1.2m Sand Bed \ 2" Vlv	0.63	2"	420	340	1146	258	POA
PWT-SDB-12-09-25	Side-Mount Deep Bed Filter - 0.9m dia \ 1.2m Sand Bed \ 2.5" Vlv	0.63	2.5"	525	340	1146	263	POA
PWT-SDB-12-10-20	Side-Mount Deep Bed Filter - 1.0m dia \ 1.2m Sand Bed \ 2" Vlv	0.78	2"	520	420	1436	330	POA
PWT-SDB-12-10-25	Side-Mount Deep Bed Filter - 1.0m dia \ 1.2m Sand Bed \ 2.5" Vlv	0.78	2.5"	650	420	1436	336	POA

*Terms and conditions apply

PWT-SDB Commercial Filter

Deep Bed Fibreglass Tank with Side-Mount Multiport Valve

DIMENSIONS

Model	A (mm)	B (mm)	C (mm)	D (mm)	E (mm)	F (mm)
SIDE-MOUNT DEEP BED FILTERS 1M SAND BED						
PWT-SDB-10-07-20	510	750	1270	1672	700	680
PWT-SDB-10-08-20	510	750	1270	1702	800	740
PWT-SDB-10-09-20	515	870	1270	1735	900	860
PWT-SDB-10-09-25	515	834	1270	1735	900	860
PWT-SDB-10-10-20	515	870	1270	1813	1000	960
PWT-SDB-10-10-25	515	1033	1270	1813	1000	960
SIDE-MOUNT DEEP BED FILTERS 1.2M SAND BED						
PWT-SDB-12-07-20	510	750	1470	1872	700	680
PWT-SDB-12-08-20	510	750	1470	1902	800	740
PWT-SDB-12-09-20	515	870	1470	1935	900	860
PWT-SDB-12-09-25	515	834	1470	1935	900	860
PWT-SDB-12-10-20	515	870	1470	2013	1000	960
PWT-SDB-12-10-25	515	1033	1470	2013	1000	960

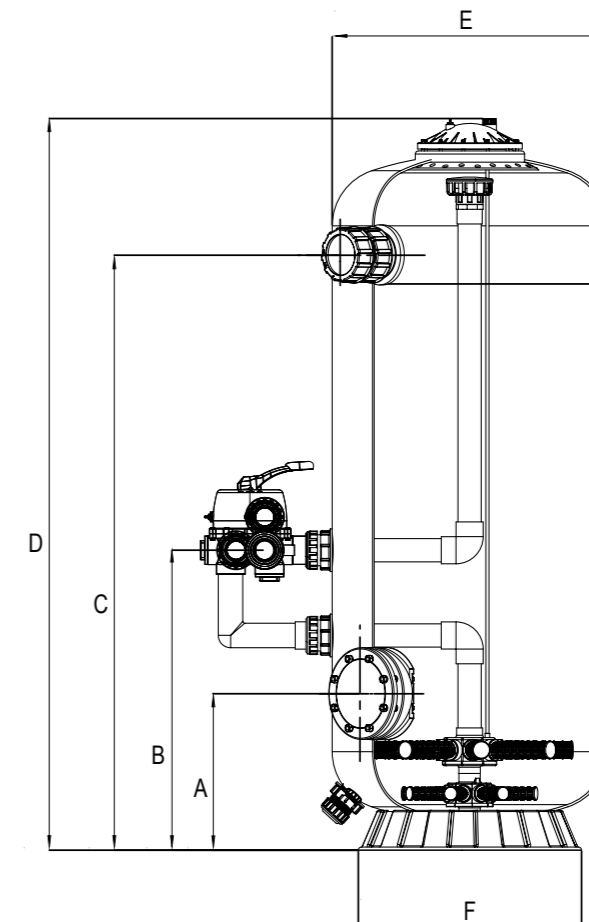

*All dimensions in mm.

PWT-E & K Commercial Filters

Fibreglass Tank with Side-Mount Flanges



FEATURES:

- Spun-woven, UV resistant fibreglass construction for exceptional strength, chemical resistance and long life.
- Max Operating Pressure 250kPa or 400kPa.
- Dual layers of Laterals.
- 4" Sight Glass.
- Available with lateral or nozzle system.
- Union Drain.
- 50m³/m²/hr filtration rate (40m³/m²/hr for deep bed).
- 5 year commercial warranty (pro-rata).*

The Pentair E&K Series satisfies the demand of different water treatment including pools installed with in-floor cleaning systems, spas, fountains and public swimming pools.

PWT-NL COMMERCIAL FILTER

Call

Model 250kPa (Laterals / Nozzles)	Model 400kPa (Laterals / Nozzles)	Product	Effective Filter Area (m ²)	Valve Conn. (in.)	Max Flow Rate (m ³ /hr)	Bckwash Flow Rate (m ³ /hr)	Sand Req'd (kg)	Gravel Req'd (kg)	Price
SIDE-MOUNT FLANGED FILTERS									
PWT-E-12-25(L/N)	PWT-E-12-40(L/N)	Side-Mount Flanged Filter 1.2m dia .	1.13	3"	56.5	40	1470	380	POA
PWT-E-14-25(L/N)	PWT-E-14-40(L/N)	Side-Mount Flanged Filter 1.4m dia .	1.54	4"	77	54	1980	410	POA
PWT-E-16-25(L/N)	PWT-E-16-40(L/N)	Side-Mount Flanged Filter 1.6m dia .	2.01	4"	100.5	70	2610	500	POA
PWT-E-18-25(L/N)	PWT-E-18-40(L/N)	Side-Mount Flanged Filter 1.8m dia .	2.54	6"	127	89	3310	620	POA
PWT-E-20-25(L/N)	PWT-E-20-40(L/N)	Side-Mount Flanged Filter 2.0m dia .	3.14	6"	157	110	4030	730	POA
PWT-E-22-25(L/N)	PWT-E-22-40(L/N)	Side-Mount Flanged Filter 2.0m dia	3.80	8"	190	133	4940	1440	POA
SIDE-MOUNT DEEP BED FLANGED FILTERS									
PWT-K-12-25(L/N)	PWT-K-12-40(L/N)	Side-Mount Deep Bed Flanged Filter 1.2m dia .	1.13	3"	45	1500	300	213	POA
PWT-K-14-25(L/N)	PWT-K-14-40(L/N)	Side-Mount Deep Bed Flanged Filter 1.4m dia .	1.54	4"	61	2250	450	228	POA
PWT-K-16-25(L/N)	PWT-K-16-40(L/N)	Side-Mount Deep Bed Flanged Filter 1.6m dia .	2.01	4"	80	2900	700	433	POA
PWT-K-18-25(L/N)	PWT-K-18-40(L/N)	Side-Mount Deep Bed Flanged Filter 1.8m dia .	2.54	6"	101	3200	900	500	POA
PWT-K-20-25(L/N)	PWT-K-20-40(L/N)	Side-Mount Deep Bed Flanged Filter 2.0m dia .	3.14	6"	125	4300	1100	712	POA
PWT-K-22-25(L/N)	PWT-K-22-40(L/N)	Side-Mount Deep Bed Flanged Filter 2.0m dia .	3.8	8"	190	5460	1440	440	POA
PWT-K-23-25(L/N)	PWT-K-23-40(L/N)	Side-Mount Deep Bed Flanged Filter 2.3m dia .	4.43	8"	175	7600	1600	594	POA
PWT-K-25-25(L/N)	PWT-K-25-40(L/N)	Side-Mount Deep Bed Flanged Filter 2.5m dia .	4.9	8"	200	8600	1800	850	POA



PWT-E & K Commercial Filters

Fibreglass Tank with Side-Mount Flanges

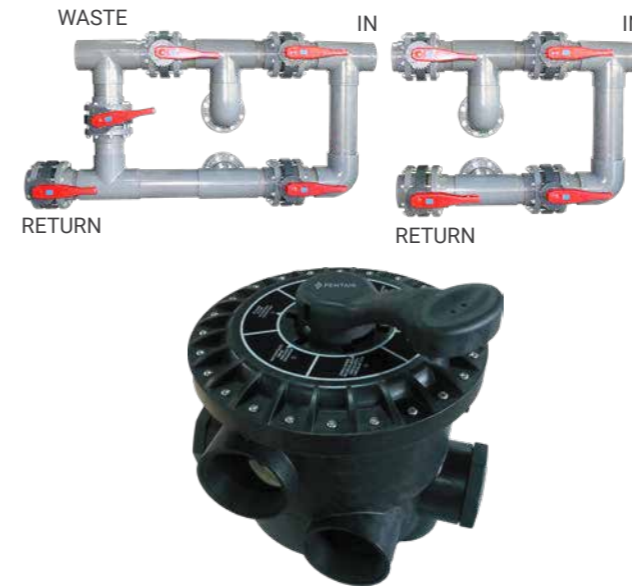

Code	Description	Price
SIDE-MOUNT FLANGED FILTERS		
PWT-NBV-30-4	4-Way Butterfly Valve 3" Ports	POA
PWT-NBV-40-4	4-Way Butterfly Valve 4" Ports	POA
PWT-NBV-60-4	4-Way Butterfly Valve 6" Ports	POA
PWT-NBV-80-4	4-Way Butterfly Valve 8" Ports	POA
PWT-NBV-30-5	5-Way Butterfly Valve 3" Ports	POA
PWT-NBV-40-5	5-Way Butterfly Valve 4" Ports	POA
PWT-NBV-60-5	5-Way Butterfly Valve 6" Ports	POA
PWT-NBV-80-5	5-Way Butterfly Valve 8" Ports	POA
PWT-MPV-30-6	6-Way Multiport Valve 3" Ports	POA
PWT-MPV-40-6	6-Way Multiport Valve 4" Ports	POA
PWT-MPV-30-6P	6-Way Multiport Valve 3" Ports, (with piping)	POA
PWT-MPV-40-6P	6-Way Multiport Valve 4" Ports, (with piping)	POA

DIMENSIONS

Model	A (mm)	B (mm)	C (mm)	D (mm)	E (mm)	Gross Weight (kg)
SIDE-MOUNT FLANGED FILTERS						
PWT-E-12	1200	1816	995	630	1180	139
PWT-E-14	1400	1816	1220	630	1180	225
PWT-E-16	1600	1916	1365	720	1210	274
PWT-E-18	1800	1956	1630	750	1190	412
PWT-E-20	2000	2060	1630	770	1260	450
PWT-E-22	2200	2376	1800	940	1440	440

Model	A (mm)	B (mm)	C (mm)	D (mm)	E (mm)	Gross Weight (kg)
SIDE-MOUNT DEEP BED FLANGED FILTERS						
PWT-K-12	1200	2080	995	565	350	307
PWT-K-14	1400	2175	1220	565	350	369
PWT-K-16	1600	2310	1365	650	350	494
PWT-K-18	1800	2320	1630	690	415	644
PWT-K-20	2000	2460	1630	770	415	746
PWT-K-23	2350	2720	1800	950	550	1078
PWT-K-25	2500	2750	1800	1050	550	1176

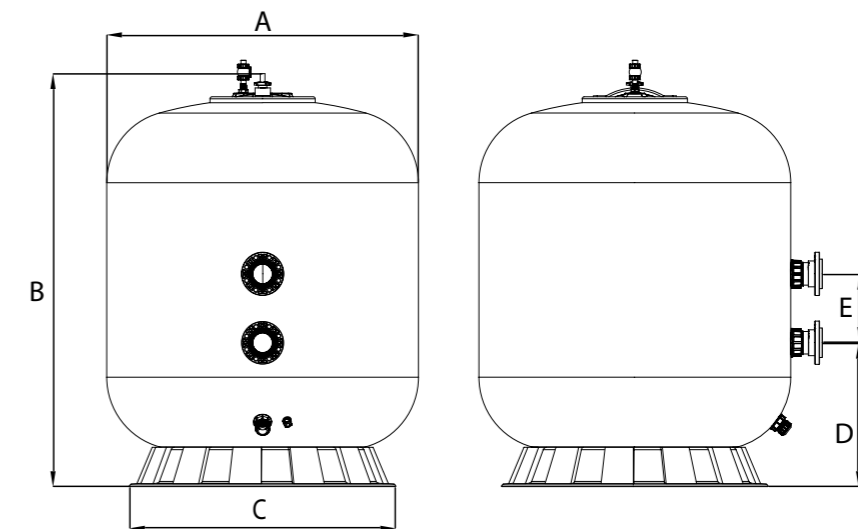

*All dimensions in mm.

PWT Commercial Filter

Horizontal Fibreglass Tank with Side Flanges



FEATURES:

- Spun-woven, UV resistant fibreglass construction for exceptional strength, chemical resistance and long life.
- Max Operating Pressure 250kPa or 400kPa.
- Even spreads of laterals.
- 4" Sight Glass.
- Manhole for servicing.
- Union Drain.
- Air vent valve.
- In-built Manometer.
- 1 year commercial warranty.*

The Pentair Horizontal Filters are suitable for high demand in filtration surface area, especially for commercial purposes. With long life and minimal servicing. Suitable for large scale water features, aquarium and commercial pool.

PWT COMMERCIAL FILTERS

Model (250kPa)	Model (400 kPa)	Product	Effective Filter Area (m ²)	Valve Conn.	Max Flow Rate (m ³ / hr)	Gravel 1-2mm (kg)	Sand 0.5-0.8mm (kg)	Price
HORIZONTAL FILTERS 1.2M DIAMETER 0.6M SAND BED DEPTH								
PWT-H-12-19-4-25	PWT-H-12-19-4-40	Horizontal Fibreglass Filter 1.2m x 1.9m (4")	1.96	4"	39	425	1100	POA
PWT-H-12-19-6-25	PWT-H-12-19-6-40	Horizontal Fibreglass Filter 1.2m x 1.9m (6")	1.96	6"	79	425	1100	POA
PWT-H-12-23-4-25	PWT-H-12-23-4-40	Horizontal Fibreglass Filter 1.2m x 2.3m (4")	2.42	4"	48	550	1425	POA
PWT-H-12-23-6-25	PWT-H-12-23-6-40	Horizontal Fibreglass Filter 1.2m x 2.3m (6")	2.42	6"	97	550	1425	POA
PWT-H-12-25-4-25	PWT-H-12-25-4-40	Horizontal Fibreglass Filter 1.2m x 2.5m (4")	2.65	4"	53	700	1750	POA
PWT-H-12-25-6-25	PWT-H-12-25-6-40	Horizontal Fibreglass Filter 1.2m x 2.5m (6")	2.65	6"	107	700	1750	POA
PWT-H-12-27-4-25	PWT-H-12-27-4-40	Horizontal Fibreglass Filter 1.2m x 2.7m (4")	2.87	4"	57	825	2075	POA
PWT-H-12-27-6-25	PWT-H-12-27-6-40	Horizontal Fibreglass Filter 1.2m x 2.7m (6")	2.87	6"	115	825	2075	POA
PWT-H-12-30-4-25	PWT-H-12-30-4-40	Horizontal Fibreglass Filter 1.2m x 3.0m (4")	3.21	4"	64	925	2325	POA
PWT-H-12-30-6-25	PWT-H-12-30-6-40	Horizontal Fibreglass Filter 1.2m x 3.0m (6")	3.21	6"	129	925	2325	POA
HORIZONTAL FILTERS 1.4M DIAMETER 0.8M SAND BED DEPTH								
PWT-H-14-19-4-25	PWT-H-14-19-4-40	Horizontal Fibreglass Filter 1.4m x 1.9m (4")	2.23	4"	45	575	2100	POA
PWT-H-14-19-6-25	PWT-H-14-19-6-40	Horizontal Fibreglass Filter 1.4m x 1.9m (6")	2.23	6"	89	575	2100	POA
PWT-H-14-25-4-25	PWT-H-14-25-4-40	Horizontal Fibreglass Filter 1.4m x 2.5m (4")	3.02	4"	60	800	2825	POA
PWT-H-14-25-6-25	PWT-H-14-25-6-40	Horizontal Fibreglass Filter 1.4m x 2.5m (6")	3.02	6"	121	800	2825	POA
PWT-H-14-30-4-25	PWT-H-14-30-4-40	Horizontal Fibreglass Filter 1.4m x 3.0m (4")	3.67	4"	73	1000	3450	POA
PWT-H-14-30-6-25	PWT-H-14-30-6-40	Horizontal Fibreglass Filter 1.4m x 3.0m (6")	3.67	6"	110	1000	3450	POA
PWT-H-14-30-8-25	PWT-H-14-30-8-40	Horizontal Fibreglass Filter 1.4m x 3.0m (8")	3.67	8"	147	1000	3450	POA

*Terms and conditions apply



PWT Commercial Filter

Horizontal Fibreglass Tank with Side Flanges

PWT COMMERCIAL FILTERS

Model (250kPa)	Model (400 kPa)	Product	Effective Filter Area (m ²)	Valve Conn.	Max Flow Rate (m ³ / hr)	Gravel 1-2mm (kg)	Sand 0.5-0.8mm (kg)	Price
HORIZONTAL FILTERS 1.6M DIAMETER 1.0M SAND BED DEPTH								
PWT-H-16-19-4-25	PWT-H-16-19-4-40	Horizontal Fibreglass Filter 1.6m x 1.9m (4")	2.47	4"	49	600	2850	POA
PWT-H-16-19-6-25	PWT-H-16-19-6-40	Horizontal Fibreglass Filter 1.6m x 1.9m (6")	2.47	6"	99	600	2850	POA
PWT-H-16-25-6-25	PWT-H-16-25-6-40	Horizontal Fibreglass Filter 1.6m x 2.5m (6")	3.36	6"	101	850	3875	POA
PWT-H-16-25-8-25	PWT-H-16-25-8-40	Horizontal Fibreglass Filter 1.6m x 2.5m (8")	3.36	8"	134	850	3875	POA
PWT-H-16-30-6-25	PWT-H-16-30-6-40	Horizontal Fibreglass Filter 1.6m x 3.0m (6")	4.1	6"	123	1050	4750	POA
PWT-H-16-30-8-25	PWT-H-16-30-8-40	Horizontal Fibreglass Filter 1.6m x 3.0m (8")	4.1	8"	164	1050	4750	POA
HORIZONTAL FILTERS 1.8M DIAMETER 1.0M SAND BED DEPTH								
PWT-H-18-25-6-25	PWT-H-18-25-6-40	Horizontal Fibreglass Filter 1.8m x 2.5m (6")	3.74	6"	112	975	4850	POA
PWT-H-18-25-8-25	PWT-H-18-25-8-40	Horizontal Fibreglass Filter 1.8m x 2.5m (8")	3.74	8"	150	975	4850	POA
PWT-H-18-30-6-25	PWT-H-18-30-6-40	Horizontal Fibreglass Filter 1.8m x 3.0m (6")	4.58	6"	137	1225	5925	POA
PWT-H-18-30-8-25	PWT-H-18-30-8-40	Horizontal Fibreglass Filter 1.8m x 3.0m (8")	4.58	8"	183	1225	5925	POA
PWT-H-18-35-8-25	PWT-H-18-35-8-40	Horizontal Fibreglass Filter 1.8m x 3.5m (8")	5.41	8"	162	1475	7000	POA
PWT-H-18-35-10-25	PWT-H-18-35-10-40	Horizontal Fibreglass Filter 1.8m x 3.5m (10")	5.41	10"	216	1475	7000	POA
PWT-H-18-40-6-25	PWT-H-18-40-6-40	Horizontal Fibreglass Filter 1.8m x 4.0m (6")	6.25	6"	125	1700	8075	POA
PWT-H-18-40-8-25	PWT-H-18-40-8-40	Horizontal Fibreglass Filter 1.8m x 4.0m (8")	6.25	8"	187	1700	8075	POA
PWT-H-18-40-10-25	PWT-H-18-40-10-40	Horizontal Fibreglass Filter 1.8m x 4.0m (10")	6.25	10"	250	1700	8075	POA
HORIZONTAL FILTERS 2.0M DIAMETER 1.2M SAND BED DEPTH								
PWT-H-20-25-6-25	PWT-H-20-25-6-40	Horizontal Fibreglass Filter 2.0m x 2.5m (6")	4.34	6"	130	1050	6575	POA
PWT-H-20-25-8-25	PWT-H-20-25-8-40	Horizontal Fibreglass Filter 2.0m x 2.5m (8")	4.34	8"	174	1050	6575	POA
PWT-H-20-30-6-25	PWT-H-20-30-6-40	Horizontal Fibreglass Filter 2.0m x 3.0m (6")	5.3	6"	159	1300	8025	POA
PWT-H-20-30-8-25	PWT-H-20-30-8-40	Horizontal Fibreglass Filter 2.0m x 3.0m (8")	5.3	8"	212	1300	8025	POA
PWT-H-20-35-6-25	PWT-H-20-35-6-40	Horizontal Fibreglass Filter 2.0m x 3.5m (6")	6.25	6"	125	1550	9475	POA
PWT-H-20-35-8-25	PWT-H-20-35-8-40	Horizontal Fibreglass Filter 2.0m x 3.5m (8")	6.25	8"	187	1550	9475	POA
PWT-H-20-35-10-25	PWT-H-20-35-10-40	Horizontal Fibreglass Filter 2.0m x 3.5m (10")	6.25	10"	250	1550	9475	POA
PWT-H-20-40-6-25	PWT-H-20-40-6-40	Horizontal Fibreglass Filter 2.0m x 4.0m (6")	7.21	6"	144	1800	10925	POA
PWT-H-20-40-8-25	PWT-H-20-40-8-40	Horizontal Fibreglass Filter 2.0m x 4.0m (8")	7.21	8"	216	1800	10925	POA
PWT-H-20-40-10-25	PWT-H-20-40-10-40	Horizontal Fibreglass Filter 2.0m x 4.0m (10")	7.21	10"	288	1800	10925	POA
PWT-H-20-45-8-25	PWT-H-20-45-8-40	Horizontal Fibreglass Filter 2.0m x 4.5m (8")	8.16	8"	163	2075	12375	POA
PWT-H-20-45-10-25	PWT-H-20-45-10-40	Horizontal Fibreglass Filter 2.0m x 4.5m (10")	8.16	10"	326	2075	12375	POA

PWT Commercial Filter

Horizontal Fibreglass Tank with Side Flanges



PWT COMMERCIAL FILTERS

Model (250kPa)	Model (400 kPa)	Product	Effective Filter Area (m ²)	Valve Conn.	Max Flow Rate (m ³ / hr)	Gravel 1-2mm (kg)	Sand 0.5-0.8mm (kg)	Price
HORIZONTAL FILTERS 2.35M DIAMETER 1.2M SAND BED DEPTH								
PWT-H-23-30-6-25	PWT-23-30-6-40	Horizontal Fibreglass Filter 2 .35m x 3 .0m (6")	5 .94	6"	119	2575	9300	POA
PWT-H-23-30-8-25	PWT-23-30-8-40	Horizontal Fibreglass Filter 2 .35m x 3 .0m (8")	5 .94	8"	178	2575	9300	POA
PWT-H-23-30-10-25	PWT-23-30-10-40	Horizontal Fibreglass Filter 2 .35m x 3 .0m (10")	5 .94	10"	238	2575	9300	POA
PWT-H-23-35-6-25	PWT-23-35-6-40	Horizontal Fibreglass Filter 2 .35m x 3 .5m (6")	7 .06	6"	141	3125	11050	POA
PWT-H-23-35-8-25	PWT-23-35-8-40	Horizontal Fibreglass Filter 2 .35m x 3 .5m (8")	7 .06	8"	212	3125	11050	POA
PWT-H-23-35-10-25	PWT-23-35-10-40	Horizontal Fibreglass Filter 2 .35m x 3 .5m (10")	7 .06	10"	282	3125	11050	POA
PWT-H-23-40-8-25	PWT-23-40-8-40	Horizontal Fibreglass Filter 2 .35m x 4 .0m (8")	8 .17	8"	163	3650	12800	POA
PWT-H-23-40-10-25	PWT-23-40-10-40	Horizontal Fibreglass Filter 2 .35m x 4 .0m (10")	8 .17	10"	327	3650	12800	POA
PWT-H-23-45-8-25	PWT-23-45-8-40	Horizontal Fibreglass Filter 2 .35m x 4 .5m (8")	9 .28	8"	186	4200	14525	POA
PWT-H-23-45-10-25	PWT-23-45-10-40	Horizontal Fibreglass Filter 2 .35m x 4 .5m (10")	9 .28	10"	371	4200	14525	POA
PWT-H-23-50-8-25	PWT-23-50-8-40	Horizontal Fibreglass Filter 2 .35m x 5 .0m (8")	10 .4	8"	208	4750	16250	POA
PWT-H-23-50-10-25	PWT-23-50-10-40	Horizontal Fibreglass Filter 2 .35m x 5 .0m (10")	10 .4	10"	312	4750	16250	POA
PWT-H-23-50-12-25	PWT-23-50-12-40	Horizontal Fibreglass Filter 2 .35m x 5 .0m (12")	10 .4	12"	416	4750	16250	POA
HORIZONTAL FILTERS 2.5M DIAMETER 1.3M SAND BED DEPTH								
PWT-H-25-35-6-25	PWT-25-35-6-40	Horizontal Fibreglass Filter 2 .5m x 3 .5m (6")	7 .34	6"	149	3175	11675	POA
PWT-H-25-35-8-25	PWT-25-35-8-40	Horizontal Fibreglass Filter 2 .5m x 3 .5m (8")	7 .34	8"	223	3175	11675	POA
PWT-H-25-35-10-25	PWT-25-35-10-40	Horizontal Fibreglass Filter 2 .5m x 3 .5m (10")	7 .34	10"	297	3175	11675	POA
PWT-H-25-40-8-25	PWT-25-40-8-40	Horizontal Fibreglass Filter 2 .5m x 4 .0m (8")	8 .62	8"	172	3725	13500	POA
PWT-H-25-40-10-25	PWT-25-40-10-40	Horizontal Fibreglass Filter 2 .5m x 4 .0m (10")	8 .62	10"	345	3725	13500	POA
PWT-H-25-45-8-25	PWT-25-45-8-40	Horizontal Fibreglass Filter 2 .5m x 4 .5m (8")	9 .8	8"	196	4300	15350	POA
PWT-H-25-45-10-25	PWT-25-45-10-40	Horizontal Fibreglass Filter 2 .5m x 4 .5m (10")	9 .8	10"	294	4300	15350	POA
PWT-H-25-45-12-25	PWT-25-45-12-40	Horizontal Fibreglass Filter 2 .5m x 4 .5m (12")	9 .8	12"	392	4300	15350	POA
PWT-H-25-50-8-25	PWT-25-50-8-40	Horizontal Fibreglass Filter 2 .5m x 5 .0m (8")	10 .98	8"	220	4850	17200	POA
PWT-H-25-50-10-25	PWT-25-50-10-40	Horizontal Fibreglass Filter 2 .5m x 5 .0m (10")	10 .98	10"	329	4850	17200	POA
PWT-H-25-50-12-25	PWT-25-50-12-40	Horizontal Fibreglass Filter 2 .5m x 5 .0m (12")	10 .98	12"	439	4850	17200	POA
HORIZONTAL FILTERS 3.0M DIAMETER 1.5M SAND BED DEPTH								
PWT-H-30-35-8-25	PWT-30-35-8-40	Horizontal Fibreglass Filter 3 .0m x 3 .5m (8")	8 .98	8"	180	4525	17850	
PWT-H-30-35-10-25	PWT-30-35-10-40	Horizontal Fibreglass Filter 3 .0m x 3 .5m (10")	8 .98	10"	270	4525	17850	POA
PWT-H-30-35-12-25	PWT-30-35-12-40	Horizontal Fibreglass Filter 3 .0m x 3 .5m (12")	8 .98	12"	360	4525	17850	POA
PWT-H-30-40-8-25	PWT-30-40-8-40	Horizontal Fibreglass Filter 3 .0m x 4 .0m (8")	10 .4	8"	208	5300	20675	POA
PWT-H-30-40-10-25	PWT-30-40-10-40	Horizontal Fibreglass Filter 3 .0m x 4 .0m (10")	10 .4	10"	312	5300	20675	POA
PWT-H-30-40-12-25	PWT-30-40-12-40	Horizontal Fibreglass Filter 3 .0m x 4 .0m (12")	10 .4	12"	416	5300	20675	POA
PWT-H-30-45-8-25	PWT-30-45-8-40	Horizontal Fibreglass Filter 3 .0m x 4 .5m (8")	11 .82	8"	236	6100	23500	POA
PWT-H-30-45-10-25	PWT-30-45-10-40	Horizontal Fibreglass Filter 3 .0m x 4 .5m (10")	11 .82	10"	355	6100	23500	POA
PWT-H-30-45-12-25	PWT-30-45-12-40	Horizontal Fibreglass Filter 3 .0m x 4 .5m (12")	11 .82	12"	473	6100	23500	POA
PWT-H-30-50-8-25	PWT-30-50-8-40	Horizontal Fibreglass Filter 3 .0m x 5 .0m (8")	13 .24	8"	265	6875	26300	POA
PWT-H-30-50-10-25	PWT-30-50-10-40	Horizontal Fibreglass Filter 3 .0m x 5 .0m (10")	13 .24	10"	397	6875	26300	POA
PWT-H-30-50-12-25	PWT-30-50-12-40	Horizontal Fibreglass Filter 3 .0m x 5 .0m (12")	13 .24	12"	530	6875	26300	POA

Call



PWT Commercial Filter

Horizontal Fibreglass Tank with Side Flanges

DIMENSIONS

Model	B (mm)	C (mm)	D (mm)	E (mm)	F (mm)	H (mm)	J (mm)	2.5 bar Weight (kg)	4 bar Weight (kg)
HORIZONTAL FILTERS 1.2M DIAMETER 0.6M SAND BED DEPTH									
PWT-H-12-19	747	325	1200	1100	1190	1900	1500	270	353
PWT-H-12-23	747	325	1200	1100	1590	2300	1500	324	418
PWT-H-12-25	747	325	1200	1100	1790	2500	1500	354	453
PWT-H-12-27	747	325	1200	1100	1990	2700	1500	382	438
PWT-H-12-30	747	325	1200	1100	2290	3000	1500	431	542
HORIZONTAL FILTERS 1.4M DIAMETER 0.8M SAND BED DEPTH									
PWT-H-14-19	847	390	1400	1130	1340	1900	1700	360	461
PWT-H-14-25	847	390	1400	1130	1840	2500	1700	413	532
PWT-H-14-30	847	390	1400	1130	2340	3000	1700	522	657
HORIZONTAL FILTERS 1.6M DIAMETER 1.0M SAND BED DEPTH									
PWT-H-16-19	945	475	1600	1440	1210	1900	1900	414	535
PWT-H-16-25	945	475	1600	1440	1710	2500	1900	516	658
PWT-H-16-30	945	475	1800	1440	2210	3000	1900	611	771
HORIZONTAL FILTERS 1.8M DIAMETER 1.0M SAND BED DEPTH									
PWT-H-18-25	1100	550	1800	1380	1560	2500	2170	570	777
PWT-H-18-30	1100	550	1800	1380	2060	3000	2170	701	888
PWT-H-18-35	1100	550	1800	1380	2560	3500	2170	811	1020
PWT-H-18-40	1100	550	1800	1380	3060	4000	2170	912	1140
HORIZONTAL FILTERS 2.0M DIAMETER 1.2M SAND BED DEPTH									
PWT-H-20-25	1200	710	2000	1720	1380	2500	2370	710	906
PWT-H-20-30	1200	710	2000	1720	1880	3000	2370	804	1024
PWT-H-20-35	1200	710	2000	1720	2380	3500	2370	898	1140
PWT-H-20-40	1200	710	2000	1720	2880	4000	2370	1001	1265
PWT-H-20-45	1200	710	2000	1720	3380	4500	2370	1093	1380
HORIZONTAL FILTERS 2.35M DIAMETER 1.2M SAND BED DEPTH									
PWT-H-23-30	1390	710	2350	1950	1270	3000	2730	920	1195
PWT-H-23-35	1390	710	2350	1950	1770	3500	2730	1035	1335
PWT-H-23-40	1390	710	2350	1950	2270	4000	2730	1178	1505
PWT-H-23-45	1390	710	2350	1950	2770	4500	2730	1362	1715
PWT-H-23-50	1390	710	2350	1950	3270	5000	2730	1562	1942
HORIZONTAL FILTERS 2.5M DIAMETER 1.3M SAND BED DEPTH									
PWT-H-25-35	1480	710	2500	2120	1850	3500	2900	1075	1403
PWT-H-25-40	1480	710	2500	2120	2350	4000	2900	1363	1587
PWT-H-25-45	1480	710	2500	2120	2850	4500	2900	1442	1812
PWT-H-25-50	1480	710	2500	2120	3350	5000	2900	1610	2022
HORIZONTAL FILTERS 3.0M DIAMETER 1.5M SAND BED DEPTH									
PWT-H-30-35	1730	710	3000	2600	1880	3500	3410	1386	1783
PWT-H-30-40	1730	710	3000	2600	2380	4000	3410	1582	2012
PWT-H-30-45	1730	710	3000	2600	2880	4500	3410	1777	2240
PWT-H-30-50	1730	710	3000	2600	3380	5000	3410	1972	2470

COMMERCIAL POOL EQUIPMENT

PWT Commercial Filter

Horizontal Fibreglass Tank with Side Flanges

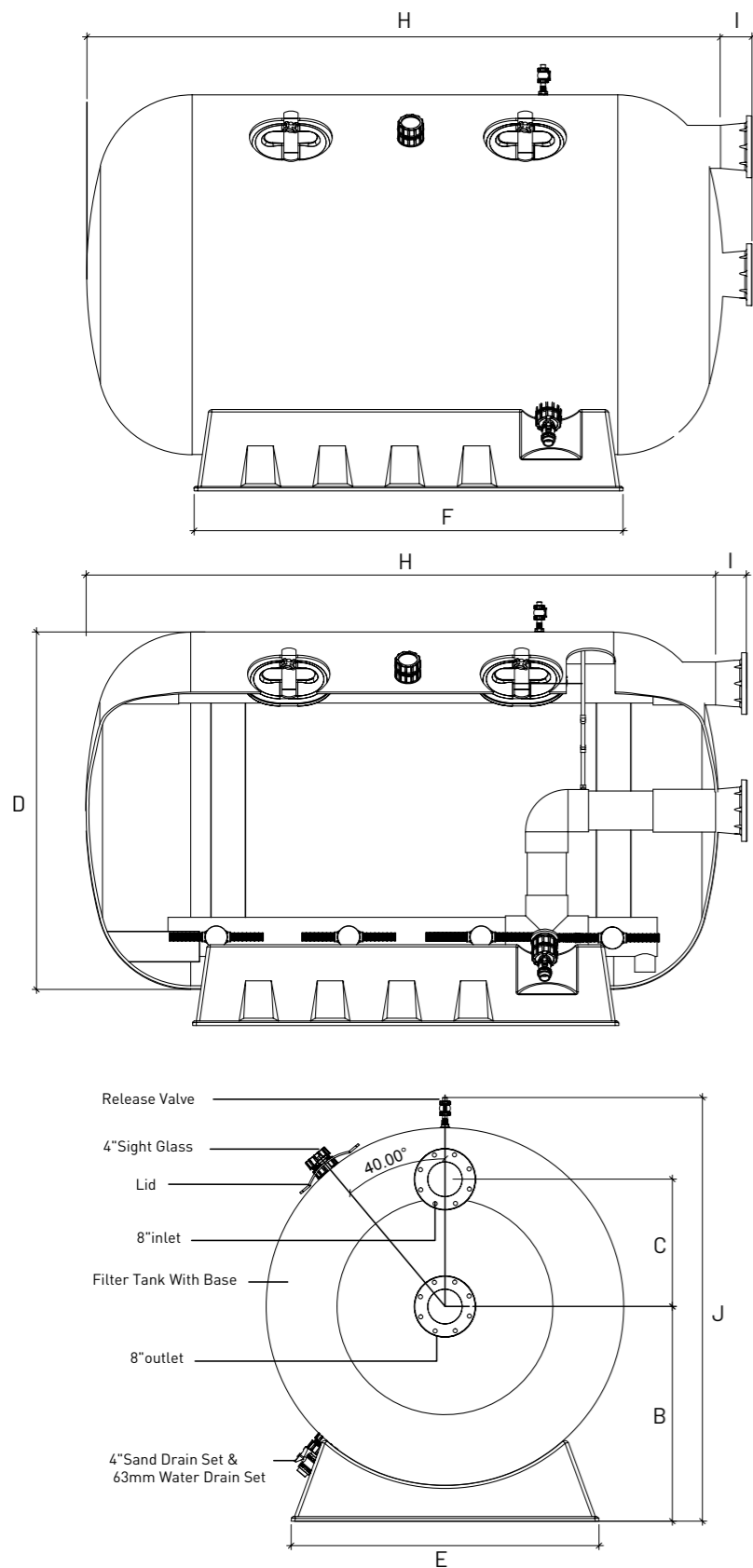

Flange	I
8" (200mm)	180mm
4" (150mm)	160mm
7" (200mm)	180mm
10" (250mm)	180mm
12" (300mm)	180mm



PWT Commercial Heat Pumps

High Performance Heat Pump



FEATURES:

- Dual Coil Titanium Heat Exchanger - Compared with normal single coil heat exchangers, enlarges the heat exchanging surface that increases efficiency.
- Copeland scroll compressors - Regarded in the industry as the best.
- Variable Speed Fan - The fan speed will be adjusted automatically to reduce the input power and noise level to achieve energy saving and silent running.
- Heats, cools and offers auto defrost.
- Corrosion protection Hydrophilic Evaporator Coating.
- Powder coated steel enclosure.

Pentair commercial heat pumps found around the world in resort, hotels, public swimming pools, schools and water parks. Wherever large bodies of water need to be reliably heated, you'll find Pentair. Pentair commercial heat pumps are equipped with a multi-unit integrated control that centralises temperature control and fault diagnostics for a much easier and more practical interface. Incorporating a master-slave configuration into the design, multiple units can work seamlessly together.

PWT COMMERCIAL HEAT PUMPS

Code	Product	Capacity kW (@24C Air)	COP	Min Flow (LPM)	Power Input (kW)	Voltage (AC-3P)	Current (A)	Carton Dim. (mm)	Price
PWT-HP-38	Pentair Commercial Heat Pump 38kW	38	5.4	200	7.1	400-415V	12	1520x800x1340	POA
PWT-HP-57	Pentair Commercial Heat Pump 57kW	57	4.5	325	12.8	400-415V	19	1520x800x1340	POA
PWT-HP-95	Pentair Commercial Heat Pump 95kW	95	5.5	485	17.3	400-415V	29	2270x1170x2040	POA
PWT-HP-120	Pentair Commercial Heat Pump 120kW	120	5.7	585	21.0	400-415V	38	2330x1220x2200	POA
PWT-HP-145	Pentair Commercial Heat Pump 145kW	145	5.7	1035	25.5	400-415V	50	2330x1220x2200	POA
PWT-HP-190	Pentair Commercial Heat Pump 190kW	190	5.8	1000	32.8	400-415V	71	2335x1220x2230	POA

*Terms and conditions apply

PWT Commercial Heat Pumps

High Performance Heat Pump

DIMENSIONS AND PERFORMANCE*

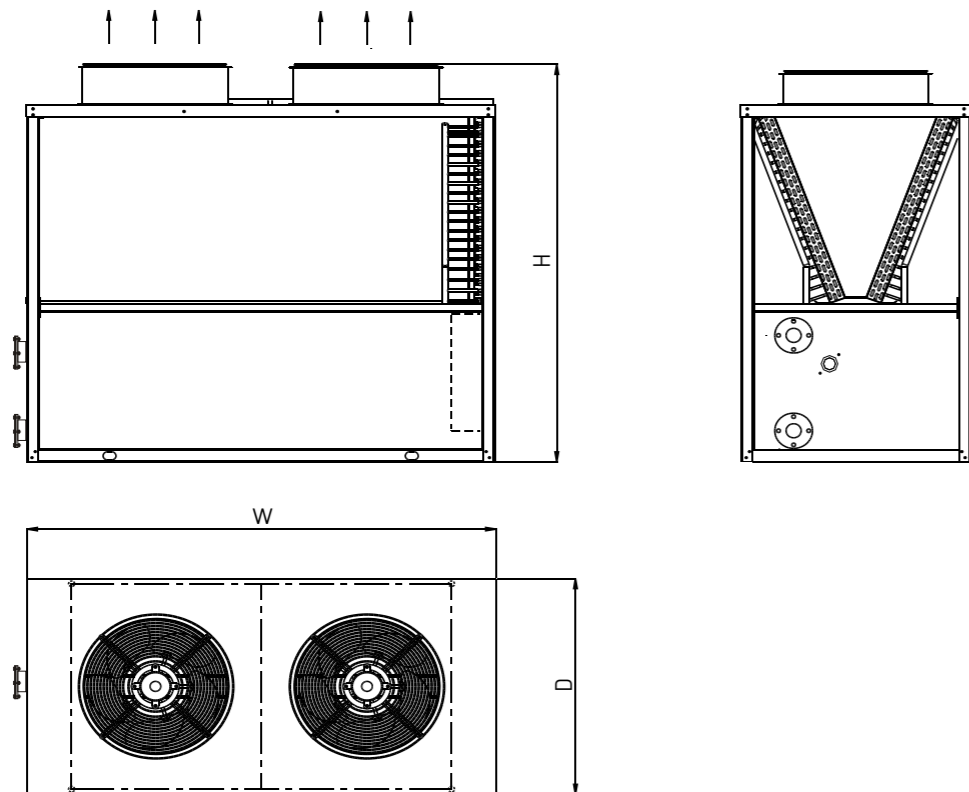

Heat Pump Model	PWT-HP-38	PWT-HP-57	PWT-HP-95	PWT-HP-120	PWT-HP-145	PWT-HP-190
W(mm)	1490	1490	2170	2175	2175	2180
D(mm)	735	735	1070	1070	1070	1070
H(mm)	1130	1130	1920	2030	2030	2060
PORTS	50MM	50MM	110MM	110MM	110MM	110MM

*All dimensions in mm.



**POOL & SPA
CHEMICALS**

Pool & Spa Chemicals

Pool Chemicals



Chlorine Granules

Liquid Chlorine

Trichlor Tablets

Multi Tablets



Safe-T Chlor

PH Up

Water Hardner

POOL CHEMICALS

MPG26

Code	Size	Description	Price
CHLORINE GRANULES (Calcium Hypochlorite 70%)			
CHG02	2kg	6 units per carton	POA
CHG04	4kg	4 units per carton	POA
CHG10	10kg	1-5 units	POA
		6-10 units	POA
		11-48 units	POA
		49+	POA
CHG20	20kg	1-4 units	POA
LIQUID CHLORINE (Sodium Hypochlorite)			
LIC05	5L	4 units per carton	POA
200gm MULTI TABLETS (Trichloroisocyanuric Acid Tablets)			
MUT01	5 Pack	12 units per carton	POA
MUT02	10 Pack	6 units per carton	POA
MUT04	20 Pack	4 units per carton	POA
20gm TRICHLOR PILLS (Trichloroisocyanuric Acid Tablets)			
TRP02	2KG	6 units per carton	POA
TRP04	4KG	4 units per carton	POA
TRP10	10KG		POA
200gm TRICHLOR TABLETS (Trichloroisocyanuric Acid Tablets)			
TRT01	5 Pack	12 units per carton	POA
TRT02	10 Pack	6 units per carton	POA
TRT04	20 Pack	4 units per carton	POA

POOL CHEMICALS

MPG26

Code	Size	Description	Price
SAFE-T CHLOR 100% SOLUABLE (Sodium Dichloroisocyanurate Dihydrate)			
STC500F	500gm	10 bags per carton (resealable flexible)	POA
STC02	2KG	6 units per carton	POA
STC04	4KG	4 units per carton	POA
STC05	5KG	4 units per carton	POA
STC10	10KG	1-9 units	POA
SHOCK N SWIM (Dichlor & Tetraborate Blend)			
SHS500F	500gm	10 bags per carton (resealable flexible)	POA
SHS01	1 KG	6 per carton	POA
ALKALINITY UP (Sodium Bicarbonate)			
ALU02F	2KG	8 bags per carton (resealable flexible)	POA
ALU04F	4KG	4 bags per carton (resealable flexible)	POA
ALU10F	10KG	2 bags per carton (resealable flexible)	POA
PH UP (Soda Ash)			
PHU02F	2KG	8 bags per carton (resealable flexible)	POA
PH DOWN (Sodium Bisulphate)			
PHD03F	3KG	6 bags per carton (resealable flexible)	POA
PHD06	6KG	4 units per carton	POA
WATER HARDENER (Calcium Chloride)			
WAH02F	2KG	8 bags per carton (resealable flexible)	POA
WAH04F	4KG	4 bags per carton (resealable flexible)	POA
WAH08F	8KG	2 bags per carton (resealable flexible)	POA



Pool & Spa Chemicals

Pool Chemicals

POOL & SPA CHEMICALS



Algae Killer

Polymeric Algaeicide

Liquid Floc

Defoamer



Maxi Clear Tablets

Filter Cleaner & Degreaser

Nil-Phos

Pool Shimmer

POOL CHEMICALS

MPG26

Code	Size	Description	Price
HYDROCHLORIC ACID			
HYA02	2L	6 units per carton	POA
HYA05	5L	4 units per carton	POA
STABILISER (Iso Cyanuric Acid)			
STA02F	2KG	8 units per carton (fast dissolving powder)	POA
ALGAE KILLER			
ALK01	1L	12 units per carton	POA
ALK02	2L	6 units per carton	POA
ALK05	5L	4 units per carton	POA
POLYMERIC ALGAEICIDE			
POA01	1L	12 units per carton	POA
COPPER FREE ALGAEICIDE			
CFA02	2L	6 units per carton	POA
CFA05	5L	4 units per carton	POA
CLARIFIER			
CLA01	1L	12 units per carton	POA
CLA05	5L	4 units per carton	POA
LIQUID FLOC			
LIF01	1L	12 units per carton	POA
ANTI CHLOR CHLORINE NEUTRALISER			
ANC02	2KG	12 units per carton	POA

POOL CHEMICALS

MPG26

Code	Size	Description	Price
DEFOAMER			
DEF05	5L	4 units per carton	POA
C5 TABLETS			
C5020	20 Pack 2kg	Pail	POA
FILTER CLEANER & DEGREASER			
FCD01	1L	6 units per carton	POA
MAXI CLEAR TABLETS			
MCT20	Carton	Counter Display 20 units	POA
MINERAL ENHANCE			
MIE15	15KG		POA
NIL PHOS			
NIL01	1L	6 units per carton	POA
NIL05	5L	4 units per carton	POA
POOL SHIMMER			
POS01	1L	6 units per carton	POA
TROPICAL STRENGTH ALGAEICIDE			
TSA01	1L	6 units per carton	POA
TEST STRIPS & KITS			
AQY		Aquachek Yellow (4:1 Chlorine)	POA
AQSPA		Aquachek Spa (6:1)	POA
AQW		Aquachek White (Salt)	POA

Pool & Spa Chemicals

Spa Chemicals



Spa Chlorine

Spa Bromine

Oxyshock



Spa pH Up

Spa Alkalinity Up

Spa Cartridge Cleaner

Defoamer

Water Hardner

SPA CHEMICALS

MPG26

Code	Size	Description	Price
SPA CHLORINE (DIDC 56%)			
SPC01	1KG	6 units/ctn	POA
SPC02	2KG	6 units/ctn	POA
SPA BROMINE			
SPB01	1KG	6 units/ctn	POA
SPB02	2KG	6 units/ctn	POA
OXYSHOCK (Potassium Peroxymonosulphate 32.5%)			
OXS01	1KG	12 units/ctn	POA
PH DOWN (Sodium Bisulphate)			
PHD01	1KG	12 units/ctn	POA
PH UP (Soda Ash)			
PHU01	1KG	12 units/ctn	POA
ALKALINITY UP (Sodium Bicarbonate)			
ALU01	1KG	12 units/ctn	POA
WATER HARDNER (Calcium Chloride)			
WAH750	750GM	12 units/ctn	POA
CARTRIDGE CLEANER			
CAC01	1L	12 units/ctn	POA
CAC05	5L	4 units/ctn	POA
DEFOAMER			
DEF500	500ML	12 units/ctn	POA
MINERAL ENHANCE FOR SPA'S			
MIE01	1KG		POA



**TERMS, ENGINEERING
& WARRANTY**

Terms & Conditions of Trade

1. TERMS AND CONDITIONS OF TRADE – 43 SOUTH LIMITED (the Company)

- These terms and conditions (Terms) together with any order for Goods and/or Services form the contract for the supply of Goods and/or Services, by the Company to the Customer (Contract).
- These Terms apply to all orders for Goods and/or Services submitted by the Customer to the Company.
- To the extent of any discrepancy between these Terms and any third party (including the Customer's) terms and conditions, these Terms prevail.

2. PRICE

- The Price is the Company's current price for the Goods and/or Services as at the Contract Date or (if applicable, and subject to clauses 4.3 to 4.5, the Price quoted by the Company.
- Where no price is stated in writing or agreed to orally the Goods and/or Services shall be deemed to be sold at the current amount as such Goods and/or Services are sold by the Company.
- Any difference between the price of the Goods and/or Services at the Contract Date and at the date of delivery, due to circumstances beyond the Company's control, is to the Customer's account and the Price shall be adjusted accordingly.
- Where the Customer requests the Company to estimate the quantity of the Goods to be supplied from sketches, plans, schedules, specifications or otherwise, the Customer agrees to pay for any variation between the estimate and the actual quantities supplied and the Contract shall be deemed to be adjusted accordingly.

3. PAYMENT

- Payment is due by the 20th of the month following the date of invoice (the Due Date).
- The Company reserves the right to require a deposit or advance payment in respect of Goods and/or Services ordered. If the Customer wishes to cancel an order, other than in accordance with the lawful exercise of a right to terminate the Contract under the Contract or at law, the Company can retain a proportion of the deposit or advance payment paid to the Company sufficient to cover the costs, expenses and losses that the Company is reasonably likely to incur as a result of the cancellation.
- If the Customer has failed to pay an amount due and owing under the Contract by the Due Date, the Company reserves the right to charge, and the Customer will pay:
 - the Company's reasonable costs (including all costs on a solicitor-client basis) incurred in, or incidental to, the enforcement or attempted enforcement of any of the Company's rights under the contract or at law; and
 - a default penalty on any moneys due but unpaid under the Contract which will be calculated on a daily basis at a rate of 2.5 per cent per month (the Default Penalty). The Default Penalty is payable from the Due Date until the date the Company receives payment of the Amount Owing. The Company's right to charge the Default Penalty is without prejudice to any of the Company's rights, powers or remedies arising after the Customer's payment default.
- The Company may allocate all amounts received by the Customer in any manner it determines including any manner required to preserve any security interest in the Goods sold under the Contract.

4. QUOTES

- A quotation by the Company is based on the current price for the Goods and/or Services (based on the Company performing the work during normal working hours) and subject to availability from the Company's usual source of supply as at the date of the quote and shall not be binding on the Company unless the Customer has accepted the Company's quote within 30 days from the date of issue (time being of the essence).
- The quotation shall be exclusive of GST unless specifically stated to the contrary;
- The Company reserves the right to alter the quotation because of circumstances beyond its control;
- Where Goods and/or Services are required in addition to the volumes specified in the quotation the Customer agrees to pay for the additional cost of such Goods and/or Services.
- Any requested variation to the Goods and/or Services covered by the Company's quotation must be notified in writing by the Customer. If the Company agrees, the Company's quotation and the Price will be adjusted accordingly. If a variation is agreed after the Contract is formed, the Contract and the Price will be adjusted accordingly.

5. CONTRACT

- These Terms shall be read subject to the express terms and conditions contained in the Contract. The Contract is subject to the Company having the Goods in stock and subject to availability from the Company's usual source of supply.
- If there is a conflict between the Customer's order and the Company's confirmation of order (including these Terms), the Company's confirmation of order (including these Terms) will prevail.
- The rights, powers and remedies provided for in the Contract (including these Terms) are in addition to, and do not limit or exclude (or otherwise adversely affect), any right, power or remedy provided to the Company by law.
- The Customer's obligation to pay amounts (other than the Price) to the Company under these Terms shall be continuing and separate obligations which will survive termination of the Contract and payment of the Price.

6. DELIVERY

- Delivery is deemed to occur when possession of the Goods is taken by the Customer.
- Delivery of the Goods will be made at the Customer's premises unless the Customer has instructed otherwise.

7. RISK AND OWNERSHIP

- All risk in and for the Goods passes to the Customer on delivery by the Company. The Customer must ensure that it is adequately insured against any damage or loss which may occur to the Goods after delivery.
- If any of the Goods are damaged or destroyed prior to property in them passing to the Customer, the Company is entitled, without prejudice to any of its other rights or remedies under the Contract (including the right to receive payment of the Price), to receive all insurance proceeds payable for the Goods. This applies whether or not the Price has become payable under the Contract. The production of the Contract (including these Terms) by the Company is sufficient evidence of the Company's right to receive the insurance proceeds without the need for any person dealing with the Company to make further enquiries.
- Property in, ownership of and title to the Goods shall not pass to the Customer until:
 - the Customer pays the Amount Owing in full and all other amounts owing under other Contracts; or
 - (if applicable) the Customer resells the Goods pursuant to the authority granted by these Terms.

- Until property in Goods passes to the Customer, the Customer holds the Goods as the Company's bailee and, as agent for the Customer, the Company (and its employees and agents) may, without prior notice, enter upon any land or premises where the Company believes the Goods are kept in order to inspect the Goods. The Customer must store the Goods so they can be identified separately from the Customer's own goods. The Company authorises the Customer, in the ordinary course of the Customer's business, to use the Goods or resell them for full consideration. This authority is revoked immediately if:
 - an Event of Default occurs; or
 - the Company notifies the Customer in writing that this authority is revoked.

8. WARRANTIES

- If the Company manufactures the Goods, the Company warrants that
 - every care will be taken to ensure that the Goods and/or Services meet the Company's standards or agreed specifications (within the limits of reasonable commercial accuracy);
 - the Company will comply with all applicable laws and governmental regulations and orders;
 - the Goods supplied will be of good material and workmanship for a period of 30 days, or such longer period as specified in writing by the Company, from the date of delivery.
- The Company makes no other warranties, whether of merchantability, fitness for a particular purpose, or otherwise, and none will be implied except in accordance with clause 12.2.
- The warranties under clause 8.1 do not apply where:
 - the Goods are repaired, modified, altered or adjusted by any person not authorised by the Company;
 - the Goods are used for purposes other than that for which they were intended;
 - the defect has arisen due to an accident or any wilful damage, negligence, neglect or default of the Customer or any third party;
 - the defect has arisen due to the incorrect installation of the Goods or abnormal working conditions;
 - the defect has arisen due to normal wear and tear on the Goods;
 - the Goods have not been stored or maintained as recommended by the Company; or
 - the Customer is in breach of any agreement with the Company (including non-payment for any Goods and/or Services).
- Any claims relating to Goods manufactured by the Company or the warranties relating to those Goods must be made by the Purchaser to the Company in accordance with clause 8.6.
- With respect to Goods not manufactured by the Company (Third Party Goods), and subject to clause 12.2, the Customer acknowledges and agrees that:
 - third party warranties will apply to Third Party Goods where applicable;
 - the Company provides no further warranties in relation to Third Party Goods;
 - the Company's obligations under clause 8.1 do not apply to the Third Party Goods; and
 - any claims relating to Third Party Goods or the warranties relating to those Third Party Goods must be made by the Purchaser to the Company in accordance with clause 8.6.
- A claim under this clause must be in writing to the Company within twelve (12) months from the date of delivery of the Goods and/or Services and no claim can be made under this clause unless and until the Price is paid in full. The Customer must:
 - give the Company notice of any defect in the Goods within 7 days of the defect becoming apparent; and
 - provide the Company with a reasonable opportunity to investigate the claim.

9. RETURN OF GOODS

- Except as provided in this clause, and subject to clause 12.2, the Customer is not entitled to return the Goods to the Company for any reason. For defective Goods which the Customer is entitled to reject:
 - the Customer must notify the Company within 7 days of delivery that the Goods are defective;
 - the Company must be given a reasonable opportunity to investigate the Customer's claim;
 - the Company will not be liable for defective Goods in the circumstances described in clauses 8.3(a) to 8.3(g); and
 - the Company will not be liable to pay the Customer any amount more than the amount (if any) the Company actually receives from the supplier of any defective Third Party Goods.
- The Company may (in its discretion) accept the return of Goods for credit but the Company may charge a handling fee of 25% of the Price and the amount of any credit will be less any freight costs. Any Goods considered for return must be unused, undamaged and still in original packaging. Subject to clause 12.2, no returns will be considered for Special Goods.

10. LIABILITY

- The Company's liability under clauses 8 and 8.6(b) will be limited in its sole discretion to:
 - restoring the Goods in conformity with the written specifications supplied by the Customer;
 - replacing the Goods; or
 - refunding the Price of the Goods.
- Any repairs will be done at such place as the Company specifies and the Customer is responsible for:
 - cartage of the Goods or parts of the Goods as is necessary to and from the place so specified; and
 - the cost or removal of defective material and fixing replacement material.
- Except as otherwise provided by clause 12.2, the Company will not be liable for:
 - failure to deliver the Goods by a specified date;
 - an event beyond the Company's control;
 - failure of the Goods however so arising;
 - testing the Goods;
 - deterioration of the Goods due to exposure to the elements after delivery;
 - any negligence, misrepresentation or other act or omission by the Customer or its agents; or
 - any loss or damage resulting directly, or indirectly, from any of the above.
- Notwithstanding any other provision of these terms and conditions and any other agreement between the Company and the Customer, but subject always to clause 12.2:
 - any liability of the Company arising under the Contract will not exceed the value of the replaced Goods in relation to which the liability has arisen;
 - the maximum aggregate liability of the Company to the Customer under these Terms and any other agreement between the Company and the Customer shall be limited to the total

revenue derived by the Company from the Customer under these Terms.

11. DEFAULT

- If an Event of Default occurs, and without prejudice to any other rights, powers or remedies the Company may have:
 - the Company may suspend or terminate the supply of Goods and/or Services to the Customer and any of its other obligations under the Contract (and any other Contract), or cancel all or any part of any order with the Customer which remains unperformed;
 - all Amounts Owing shall immediately become due and payable notwithstanding that the due date for payment has not arisen; and
 - the Company may enforce any security interest granted to it by the Customer.
- The Company will not be liable to the Customer for any loss or damage the Customer suffers because the Company exercises any rights, powers or remedies after the occurrence of an Event of Default, including under this clause.
- The Customer agrees that, at any time after an Event of Default has occurred or at any time if any Goods are at risk, the Company may:
 - take possession of any Goods; and/or
 - sell or dispose of any Goods in such manner and generally on such terms and conditions as the Company thinks fit, and, in each case, otherwise do anything the Customer could do in relation to the Goods. The Company and the Customer agree that section 109(1) of the PPSA is contracted out of in respect of particular Goods if and only for so long as the Company is not the secured party with priority over all other secured parties in respect of those Goods. As agent for the Customer, the Company (and its employees and agents) may, without prior notice, enter upon any land or premises where the Company believes the Goods are kept in order to take possession of and/or remove them. The Customer agrees to procure all other rights (including consents) necessary to enable, and to indemnify the Company (and its employees and agents) against any liability incurred in connection with, such entry, taking of possession and removal.

12. CONSUMER GUARANTEES ACT 1993 (CGA)

- If the Customer is not a consumer as defined in the CGA or the Customer acquires or holds itself out as acquiring the Goods under the Contract for the purposes of a business, nothing in the CGA will apply to the supply of the Goods.
- In the case of any Customer (to which clause 12.1 does not apply), the provisions of the Contract (including these Terms) will only apply to the extent that such provisions do not limit or exclude any provisions of the CGA and will take effect subject to the provisions of the CGA.
- Where the Customer supplies the Goods:
 - in trade to a person acquiring them for business purposes, it must be a term of the Customer's contract with the purchaser that the Consumer Guarantees Act 1993 does not apply in respect of the Goods;
 - to any other person, the Customer must not give or make any undertaking, assertion or representation in relation to the Goods without the Company's prior approval in writing.
- The Customer shall pass on any written product information supplied by the Company to the purchaser and agrees to indemnify the Company against any liability or cost incurred by the Company under the Consumer Guarantees Act 1993 as a result of any breach by the Customer of the obligations contained in these Terms.

13. PPSA

- The Customer grants the Company a Security Interest in the present and after-acquired Goods as Security for all amounts owing by the Customer to the Company and performance of the Customer's obligations under the Contract. To the extent permitted by law, the Customer and the Company contract out of:
 - section 114(1)(a) of the PPSA; and
 - the Customer's rights referred to in sections 107(2)(c),(d),(h) and (i) of the PPSA.
- The Customer waives its right to receive a copy of any verification statement in respect of any financing statement relating to any security interest granted to the Company by the Customer.
- The Customer agrees to indemnify the Company, upon demand, for all costs and expenses (including legal fees) incurred by the Company:
 - as a result of the occurrence of an Event of Default (including upon actual or attempted enforcement of any security interest granted to the Company by the Customer); and
 - in complying with any demand made under section 162 of the PPSA.
- On the request of the Company, the Customer shall promptly do all things (including signing any delivery docket and/or invoice) and provide all information necessary to enable the Company to perfect and maintain the perfection of any security interest granted to the Company by the Customer (including by registration of a financing statement).

14. TWO OF MORE CONTRACTS

- Where, at any time, there is an Amount Owing under two or more Contracts, the Company may apply a payment made by the Customer under the Contract in such manner (including in such order and to any amounts owing to the Company, including under another Contract) as the Company thinks fit (despite any direction to the contrary and whether before or after any default by the Customer). The security interest provided for by these Terms and created by the Contract also secures the Amount Owing under any other Contract, and each Contract (and these Terms) shall be construed accordingly.

15. DISPUTE RESOLUTION

- The parties will act in good faith and make reasonable endeavours to resolve any dispute between them arising out of or in connection with these Terms or Contract (Dispute).
- If the parties are unable to resolve a Dispute within 14 days of it being raised for discussion, either party may, by written notice to the other party, require that the Dispute be submitted for mediation by a single mediator nominated by the chairperson of Arbitrators' and Mediators' Institute of New Zealand. In the event of any such submission to mediation:
 - the mediator will be deemed to be not acting as an expert or an arbitrator;
 - the mediator will determine the procedure and timetable for the mediation; and
 - the cost of the mediation will be shared equally between the parties (unless otherwise agreed).
- If there is a Dispute, each party will continue to perform its obligations under these Terms and any Contract, including to pay any undisputed amounts when due, as far as practical given the Dispute.
- Each party agrees not to start any action in relation to a Dispute until it has complied with the process described in this clause 15, unless action is necessary to preserve the party's rights.

16. USE OF INFORMATION

- The Customer agrees that:

Terms & Conditions of Trade

- the Company may collect information about the Customer from the Customer or any other person (including any credit or debt collection agencies) in the course of the Company's business, including credit assessment, debt collecting and direct market activities, and the Customer consents to any person providing the Company with such information;
- the Company may use any information it has about the Customer relating to the Customer's credit worthiness and give that information to any other person, including any credit or debt collection agency for credit assessment and debt collection purposes;
- any other information collected by the Company about the Customer is accessed or collected for use in the course of its business, including direct marketing activities;
- it must notify the Company of any change in circumstances that may affect the accuracy of the information provided by the Customer to the Company.

- If the Customer is an individual, i.e.: a natural person, the Customer has rights under the Privacy Act 1993 to access and request the correction of any personal information which the Company holds about the Customer.

17. GENERAL

- Authority: Each party warrants that it has the power to enter into, execute and perform the Contract (including these Terms) and has obtained all necessary consents to enable it to do so.
- Intellectual Property: All intellectual property owned by, or proprietary to, a party at the date of the Contract will remain owned exclusively by that party.
- Assignment: The Customer must not transfer or assign its rights or obligations under the Contract to anyone else without the Company's prior consent in writing.
- Amendments: These Terms may be amended by the Company from time to time by publication on the Company's website and/or by notice in writing to the Customer and such amendments will apply to all future Contracts after the date of the amendment.
- Remedies cumulative: The rights and remedies provided in these Terms are cumulative and not exclusive of any rights or remedies provided by these Terms or law.
- Severance: If any provision of these Terms or of any Contract is illegal, invalid or unenforceable, that provision shall be read down to the extent necessary to make it legal, valid and enforceable.
- Waiver: Any failure or delay by either party in exercising any of its rights under these Terms will not operate as a waiver of its rights and will not prevent such Party from subsequently enforcing any right or treating any breach by the other Party as a repudiation of the Contract.

18. WORDS USED IN THESE TERMS

- Definitions: In these Terms, unless the context requires otherwise:
 - Amount Owing means, at any time in respect of the Contract, the unpaid part of the Price and any other amounts which the Company is entitled to recover under the Contract (including these Terms);
 - Contract Date means:
 - for a Contract arising from an order placed by the Customer, the date the Company accepted the order; or
 - for a Contract arising from a quotation from the Company, the date the Company receives written notification of acceptance of the quotation or, if the Company receives no written notification of acceptance of the quotation, the date the Company receives a form of acceptance that the Company (in its absolute discretion) treats as a valid acceptance;
 - Company means 43 South Limited (Company number 6232188);
 - Customer means the entity or individual to whom the Company supplies Goods and/or Services. For the avoidance of doubt, "Customer" does not include any third party to whom the Customer on sells or resells the Goods.
 - Event of Default means any of the following:
 - the Customer fails to comply with the Contract or any other Contract or agreement with the Company;
 - the Customer is subject to any event which is in the nature of dissolution, winding up, bankruptcy, liquidation, insolvency or receivership, or which generally precedes such an event;
 - an event occurs or information becomes known to the Company, which in the Company's opinion, might materially affect the Customer's credit worthiness, the value of the Goods, or the Customer's ability or willingness to comply with its obligations under the Contract or any other Contract or agreement with the Company;
 - any guarantor of the Customer's obligations under the Contract is in default under any agreement between the guarantor and the Company;'
 - Goods means all goods supplied by the Company to the Customer from time to time under the Contract, provided that:
 - (but solely for the purposes of the application of the PPSA) where the goods supplied are inventory of the Customer, then all references to Goods shall, in respect of those goods, be read as references to inventory for so long as they are held as inventory; and
 - references to Goods shall mean the goods described or referred to (whether by item or kind or otherwise) in the relevant delivery docket or invoice (or its equivalent, what ever called) prepared by the Company on the basis that each such delivery docket or invoice (or its equivalent) is deemed to be assented to by the Customer and to be included in and form part of the Contract; and
 - unless the context requires otherwise, Goods shall include all proceeds of such goods and any objects, products or mass which the goods subsequently become part of;
 - GST means Goods and Services Tax;
 - PPSA means the Personal Property Securities Act 1999;
 - Price means the price of Goods and (if applicable) any incidental Goods and/or Services agreed between the Company and the Customer, subject to any variation in accordance with these Terms and, unless specifically agreed otherwise in writing, is expressed before the addition of GST and any other applicable taxes and duties; and
 - Services means all services and advice provided by the Company to the Customer and shall include without limitation the importing, design, manufacture and servicing of water treatment chemicals and water treatment equipment programs and systems and all charges for labour, hire charges, insurance charges, or any fee or charge associated with the supply of Goods and/or Services by the Company to the Customer.
 - Special Goods means Goods which are not contained in the Company's current printed price book for Goods and Services as at the Contract Date and/or Goods made to the Customer's specifications.

Please refer to our website for manufacturers' terms and conditions

PENTAIR WARRANTY SCHEDULE						
S.No	APPLICATION GROUP	PRODUCT	WARRANTY PERIOD	LABOUR COVER	WARRANTY TYPE	EXCEPTIONS
1	HOME & GARDEN	JS / JM / SMH Series	2 years	1 year	Workshop only	
2		CBI Series	2 years	1 year	Workshop only	
3		TankBuddy	2 years	1 year	Workshop only	
4		Dominator	2 years	1 year	Workshop only	
5		Intellimaster	3 years	3 years	Workshop	
6		WaterSwitch	2 years	2 years	In-field	In-Field included only when fitted to a Homemaster pump and labour extended to 2 years.
7		Press Control / Mascontrol	1 year	1 year	Workshop only	2 year warranty applies when purchased as a full pressure system (SMHP, JSP, SSGP - parts only).
8		Packaged Pressure Kits	1 year	1 year	Workshop only	
9	RURAL WATER	JJ and OJ Series	2 years	1 year	In-field / workshop	
10		SSS Series	1 year	1 year	Workshop only	
11	ENGINE DRIVE PUMPS	Centrifugal / Transfer Pumps	1 year	1 year	Workshop only	In-field included with 18 series only.
12		Blazemaster Pumps	2 years	1 year	Workshop only	Excludes engine: Manufacturer warranty details in owners manual / hand book.
13		Miniblaze	1 year	Nil	Replacement only	
14		Hi-Flo Range (384)	1 year	1 year	Workshop only	Excludes engine:Manufacturer warranty details in owners manual / hand book.
15		GP960 [Engine Drive]	1 year	1 year	Workshop only	Excludes engine:Manufacturer warranty details in owners manual / hand book.
16		LCT65VR	2 years	1 year	Workshop only	
17		Jung Pumpen	2 years	1 year	Workshop only	
18	SUMP & DRAINAGE	VF150	1 year	Nil	Replacement	
19		Sta-Rite CSM Range	2 years	1 year	Workshop only	
21		Omnia, Drenox & Biox	2 years	1 year	Workshop only	
22	GROUNDWATER	4" Borehole pumps	2 years	1 year	Workshop only	
23		4" Borehole Motors	2 years	1 year	Workshop only	
24		Pentek Intellidrive	2 years	1 year	Workshop only	
25		Submersible Bore Controls	1 year	1 year	Workshop only	
26	PRESSURE TANKS	Steel Pressure Tanks	5 years	1 year	Workshop only	
27		Fibrewound Pressure Tanks	5 years	1 year	Workshop only	
29	FLOTEC	All models	2 years	1 year	Workshop only	
30	SHURFLO	Agriculture Pumps	1 year	Nil	Replacement only	Return to Pentair Melbourne at the customers expense for warranty assessment. Replacement only if matter is considered warrantable.
31	AQUACULTURE	Seabass	1 year	1 year	In-field / workshop	
32	POOL PUMPS	Max-Boost, Leisure Time Pool Pumps (LTP, LTPA & LTPS Series)	2 years	1 year	In-field / workshop	
33		Onga Pool Pumps (Pantera Series, Eco800, Silentflo)	3 years	1 year	In-field / workshop	
34		Pentair/Sta-Rite (Max-e-pro, Whisperflo, EnviroMAX)	3 years	1 year	In-field / workshop	
35		IntelliFlo Pumps	5 years	2 years	In-field / workshop	2 years commercial applications.
36		5PSP Series Commercial Pumps	1 year	1 year	In-field / workshop	Valid for commercial applications
37	POOL SAND FILTERS	Onga Sand Filters (Pantera, Leisuretime II)	10 years*	1 year	In-field	*10 year warranty is pro-rata 100% replacement value from 0-5 years from purchase, 50% replacement value from 5-10 years from purchase date. This applies to sand filter tank. MPV, and laterals are warranted for 1 year only.
38		Pentair/ Sta-Rite Sand Filters (CristalFlo II, Triton, Tagelus)	10 years*	1 year	In-field	
39		PWT Commercial Filters	1 year	1 year	In-field	Valid for commercial applications
40	POOL CARTRIDGE FILTERS	Onga Cartridge Filters (Pantera Series)	5 years*	1 year	In-field	*10 year warranty is pro-rata 100% replacement value from 0-5 years from purchase, 50% replacement value from 5-10 years from purchase date. This applies to filter tank only. Excludes cartridges, which are warranted against manufacturing defects for 6 months.
41		Sta-Rite Cartridge Filters (Posi-Clear RP)	10 years*	1 year	In-field	
42		Pentair Cartridge Filters (Clean & Clear Plus, FreeFlo)	10 years*	1 year	In-field	
43	POOL DE FILTERS	Sta-Rite DE Filters	10 years*	1 year	In-field / workshop	*10 year warranty is pro-rata 100% replacement value from 0-5 years from purchase, 50% replacement value from 5-10 years from purchase date. This applies to filter tank only. Lid and locking ring are covered for 12 months. Excludes elements, which are warranted against manufacturing defects for 6 months.
44	POOL CLEANERS	Legend, Legend II, Racer, Racer LS	2 years*	1 year	In-field / workshop	*Excludes wearable parts including tyres, flip hose and leaf bag.
45		Prowler 920	2 years	Nil	Workshop only	Prowlers are covered by a back-to-base warranty, they must be returned to Pentair's special robot service provider. Return expense is covered by Pentair.
46		HammerHead, MakoShark, Rebel, Great White II	3 years	Nil	Replacement only	*Excludes skirts, seals, foot pads and tyres which are wear and tear items and covered for 1 year against defects only. Hammerhead and MakoShark oscillator is covered with lifetime warranty.
47		Pool Shark, Sand Shark, Lil' Shark, Lil' Hammer	2 years	Nil	Replacement only	*Excludes brushes, seal flaps and foot pads which are wear and tear items and covered for 1 year against defects only.
48	POOL HEATERS	Mastertemp	2 years*	1 year	In-field only	*1 year for commercial.
49	POOL HEAT PUMPS		15 years*		Titanium Heat Exchanger	*15 years guarantee against corrosion when used with water chemistry in line with guidelines specified in UltraTemp owner's manual. Replacement part supplied.
			15 years*		Cabinet	*15 years guarantee against cabinet failure due to environmental factors when installed in accordance with UltraTemp owner's manual. Does not include physical damage caused by external causes. Does not include discolouration. Replacement parts supplied.
			5 years*		Compressor	*5 year guarantee against manufacturing defects. Replacement part supplied.
			3 years*		Refrigeration circuit	*3 year guarantee against manufacturing defects on refrigeration circuit and components. Pentair will replace complete heat pump. Does not include temperature sensors or limit switches, as these are replaceable components.
			3 years*		Parts	*3 year guarantee on all other parts. Replacement parts supplied.
50	POOL CHLORINATORS	Intellichem	1 year	1 year	In-field only	
51		Solenoid Doser	2 years	Nil		
52		Rainbow Tablet Feeders	1 year	Nil	Replacement only	
53		SR Series Chlorinator	3 years	Nil		
54		FreeFlo Salt Chlorinators	5/3 years*	1 year	In-field / workshop	*5 year pro-rata warranty on cell. 3 years power pack.
55	POOL BLOWERS & AIR SWITCHES	Air Blowers / Air Switches	1 year	Nil	Replacement only	
56	POOL CONTROLLERS	IntelliTouch / EasyTouch / SunTouch	2 years	1 year	In-field only	
57		Wired and Wireless Controllers / Accessories	1 year	Nil	Replacement only*	*In field warranty applies as part of complete system with EasyTouch, IntelliTouch or SunTouch.
58		SolarTouch	2 years	1 year	In-field only	
59	POOL LIGHTS	Swimming Pool & Spa Lights	1 year	Nil	Replacement only	Excludes globes.
60	POOL ACCESSORIES	Maintenance Equipment / Handover Kits	6 months	Nil	Replacement only	Warranty covers manufacturing defects only.
61		Flip Hose	1 year	Nil	Replacement only	
62		Skimmer Boxes / Main Drains / Hydrostatic Valves / Inlets / Outlets	1 year	Nil	Replacement only	
63		Auto Refill Assembly	1 year	Nil	Replacement only	
64	POOL FEATURES	Colorcascade / MagicStream Laminars/ Magic Bowl	1 year	1 year	In-Field*	*In-field warranty covers replacement of LED light engines/jets only. Niches are replacement only.
65		MagicFalls / Deck Jet / Deck Jet II	1 year	Nil	Replacement only	
66	RESIDENTIAL FILTERS	Omni Household Filters / Housings	1 year	Nil	Replacement only	Excludes consumable elements such as filter cartridges, o-rings and cracking due to over tightening of fittings.

PENTAIR WARRANTY SCHEDULE						
S.No	APPLICATION GROUP	PRODUCT	WARRANTY PERIOD	LABOUR COVER	WARRANTY TYPE	EXCEPTIONS
67	FILTRATION / FOOD SERVICE	Shurflo Food Service Equipment	1 year	Nil	Replacement only	
68		Shurflo BIB pump / Yellow Clip	5 years	Nil	Replacement only	
69		Everpure Manifold and Filter Heads	3 years	Nil	Replacement only	
70		Everpure MRS Reverse Osmosis	1 year	1 year	In-Field only	Excludes consumable elements such as filter cartridges, o-rings and cracking due to over tightening of fittings.
71		Everpure HSD System	3 years	1 year	In-Field only	
72		Other Everpure Equipment	1 year	Nil	Replacement only	
73		RO Mate Tanks	1 year	Nil	Replacement only	
74		Water Softeners	1 year	Nil	In-Field only	Excludes consumable elements such as filter cartridges, o-rings and cracking due to over tightening of fittings.

PENTAIR WARRANTY TERMS & CONDITIONS

Pentair Australia Pty Ltd ACN 004 856 204 and its related entities ("Pentair") warrants that, subject to the terms and conditions below, when it's products are used for the purpose for which they were designed, they will be free of material and manufacturing defects at the time of the original purchase. Any defects found in the products should be reported as soon as the fault is discovered.

In Australia:
Our goods come with guarantees that cannot be excluded under the Australian Consumer Law. You are entitled to a replacement or refund for a major failure and for compensation for any other reasonably foreseeable loss or damage. You are also entitled to have the goods repaired or replaced if the goods fail to be of acceptable quality and the failure does not amount to a major failure.

CAREFULLY READ THE INSTRUCTIONS SUPPLIED PRIOR TO USING ANY PENTAIR PRODUCT.

All products are to be installed and operated in accordance with the instructions provided. This warranty will not apply if any product is used in a manner other than in accordance with the instructions.

1. What does the warranty cover

Pentair warrants its products to be free of defects in material and workmanship during the warranty period. If a product proves to be defective in material or workmanship during the warranty period, then Pentair will, at its sole discretion repair or replace the product with a like product. Replacement products or parts may include re-manufactured or refurbished parts or components.

2. How long the warranty is effective internationally

This Pentair product is warranted for 12 months for all parts from the date of the first consumer purchase. Should any parts fail as a result of a defect in material or workmanship within the specified period, the part will be replaced free of charge. (This does not include travel charges, removal and reinstallation charges.)

3. How long the warranty is effective locally

Please refer to the attached Warranty Schedule detailing the warranty period and coverage.

ii) All Pentair products warranties commence from the date of first consumer purchase.

iii) Where this Pentair product is sold for business purposes as defined in the relevant consumer protection law the warranty shall be for a period of six months from the date of purchase by the consumer.

4. Who the warranty protects

This warranty is valid only for the consumer purchaser.

5. How to claim the warranty

To claim under this warranty the consumer should immediately cease using the goods when an alleged product issue arises. For in-field service, the consumer should promptly notify a Pentair local dealer, within thirty (30) days after discovery of an alleged product issue. Detailed warranty claim information will be requested at this time and must be supplied by the consumer. For a workshop warranty, the consumer should promptly return the product to a Pentair local dealer, within thirty (30) days after discovery of an alleged product issue. Detailed warranty claim information will be requested at this time and must be supplied by the consumer. Your Pentair Service Agent may be found here: <http://www.onga.com.au/dealerlocator>

6. What the warranty does not cover

- Damage, deterioration or malfunction resulting from:
 - Accident, misuse, negligence, fire, water, lightning, or other acts of nature, modification or failure to follow instructions supplied with the product;
 - Repair or attempted repair by anyone not authorized by Pentair;
 - Any damage to the product due to shipment;
 - Removal or installation of the product;
 - Causes external to the product such as electric power fluctuations or failure;
 - Use of supplies or parts not meeting Pentair specifications;
 - Normal wear and tear;
 - Product consumables. i.e. mechanical seals, impellers, bearings, rings gaskets and electrical cables.
 - Any unauthorized changes or tampering or partial disassembly of the product;
 - Water ingress or exposure to abnormal corrosive conditions, abrasive chemicals or "run dry" condition
 - Any other cause which does not relate to a product defect.
- Damage caused to the products arising from the use of another manufacturer's product.
- Ingress of insects or invertebrates into the unit causing electrical malfunction. Care should be taken to avoid this occurrence.
- Products other than products supplied by Pentair.
- Products that are not installed in accordance with the owner's manual.
- Products that are not installed by a suitably qualified person trained in the installation and operation of such products.
- General Service and Maintenance

7. Limitation of Liability

To the extent permitted by law, Pentair's liability for breach of a guarantee implied by any law in relation to goods Pentair supplies that are not of a kind ordinarily acquired for personal, domestic or household use or consumption, except for implied guarantees as to title to goods supplied, a purchaser's right to undisturbed possession of goods supplied and undisclosed securities over goods supplied, is limited to the replacement of the goods, the payment of the cost of replacing the goods or the payment of the cost of acquiring equivalent goods.

8. Exclusion of damages

To the extent permitted by law, Pentair liability is limited to the cost of the repair or replacement of the product.

Pentair will not be liable for:

- Damage to other property caused by any defects in the product, damages based upon inconvenience, loss of use of the product, loss of time, loss of profits, loss of business opportunity, loss of goodwill, interference of business relationships, or other commercial loss, even if advised of the possibility of such damage.
- Any other damage arising as a result of weather or natural disaster.
- Any claim against the customer by any other party.

9. Proof of purchase

Pentair reserves the right to reject any warranty if no proof of purchase is provided. A valid proof of purchase will be requested by the Service Agent prior to any works being carried out by the Pentair Service Agent.

A valid proof of purchase includes the following:

- Tax Invoice from place of purchase.
- Tax Receipt from place of purchase.
- Certificate of Occupancy.

10. Service Calls

- All in-field service calls will require the consumer to provide the service agent with either a deposit which is fully refundable upon acceptance of the warranty claim or credit card details as a form of security.
- The consumer will only be charged for services where the Pentair Service Agent determines the product failure is a result of, or directly relating to, any of the items listed in section 5 of these terms & conditions.
- Refusal to provide either a deposit that is fully refundable upon assessment or Credit Card details for security may result in the Pentair Service Agent refusing to attend the Service Call.
- Any warranty application submitted that does not contain the consumers details may result in the Pentair Service Agent refusing to attend the Service Call.
- Any product warranty application that involves mains or gas lines the Service Agent will require a Certificate of Compliance for the original installation.
- In-field service will not be provided to consumers who purchased their product via the internet. The consumer shall return the product to the place of purchase, a Pentair Service Agent or shall accept the charges related to in-field service in order to receive warranty service on the product.

11. Spare Parts

Spare parts are stocked for a reasonable period of time following last production. Pentair does not warrant that spare parts will be made available for the whole of the reasonable period and reserves its right to cease supplying spare parts, or providing facilities for repair of spare parts in circumstances which are beyond its control including the requirement to remove spare parts from sales as a consequence of changes in the law or otherwise at its absolute discretion.

12. General Maintenance

It is the responsibility of the consumer to ensure the product is free: from general debris; any foreign matter; and weather exposure.

For general service & maintenance please refer to your nearest Dealer and or Service Agent.

13. Definitions

13.1 Infield warranty

- As per the attached warranty schedule any Pentair product that carries an in-field warranty means that the service agent is required to attend the site of the faulty product, subject to clause 13.1(iii).
- Any in-field issues determined not to be covered by this warranty will result in all associated costs for the in-field service provided to be invoiced to the consumer and those costs will not be covered by the Pentair product warranty.
- Any travel associated to the Pentair Warranty Claim will be covered up to 100km round-trip from place of purchase. Any kilometres outside this range will be payable by the consumer.
- Infield warranty is not provided for online purchases.

13.2 Workshop warranty

As per the attached warranty schedule any Pentair product that carries a work shop only warranty means; the faulty product must be taken or freighted at consumer cost; to the nearest Pentair Service Agent. The consumer is able to request an in-field service / repair; however this would be at the consumer's own cost.

Any workshop issues determined to be no fault / cause of the Pentair product; will result in all associated costs to the service provided; being invoiced to the consumer and will not be covered under the Pentair product warranty.

13.3 Replacement warranty

As per the attached warranty schedule any Pentair product that carries a replacement warranty means; that the service agent will fully replace the faulty Pentair product at no cost to the consumer if determined warrantable.

The faulty product must be taken to the closest Pentair Service Agent for replacement warranty otherwise all costs associated will be at the consumers cost and is not covered under the Pentair product warranty.

14. Effective law

This warranty gives you specific legal rights, and you may also have other rights which vary depending on where the product was purchased and the consumer protection or other law that applies in that place. Nothing in this warranty limits or restricts, or is intended to derogate from, any right or remedy which the purchaser or ultimate user of the product may have pursuant to Australian federal or Consumer Guarantees Act, Fair Trading Act or any other relevant and applicable New Zealand legislation or authority and where necessary shall so be read and construed in light of the applicable legislation. The terms of this warranty policy may be inconsistent with the warranty statement in the products owner's manual. To the extent of any inconsistency the terms of this warranty shall prevail.

These terms and conditions must be read in conjunction with the relevant product identified in the Warranty Schedule. A copy of the warranty schedule is available online at : <http://www.onga.com.au/Terms>



Pentair Australia
1-21 Monash Drive,
Dandenong South, Vic 3175

National Customer Service: Phone: 1300 137 344
Fax: 1800 006 688

National Dealer Locator: Phone: 1800 664 266
Email: au.sales@pentair.com
Web: www.pentair.com.au

© Information contained here-in remains the property of Pentair Pty Ltd. Any reproduction, display, publication, modification or distribution is strictly prohibited without the prior written permission of Pentair Pty Ltd.

Disclaimer: Pentair reserves the right to change product warranty type and terms.

ENGINEERING

APPROXIMATE WATER REQUIREMENTS

Application	Litres	Gallons
Shower	5-15 lpm @ 140 kPa	1-3 gpm @ 20 psi
Fill Bath	140	30
Flush Toilet	5-15 lpm	1-3
Lawn Sprinkler	15 lpm @ 140 kPa	3 gpm @ 20 psi
1/2" Tap	45 lpm @ 140 kPa	10 gpm @ 20 psi
Horses	45 per day	10 per day
Cattle	55 per day	12 per day
Milking Cows	135 per day	30 per day
Sheep	4-9 per day	1-2 per day
Pigs	15 per day	3 per day
100 chickens	23 per day	5 per day

The daily requirement should be able to be pumped in three hours in order to ensure adequate capacity to meet peak load demands.

VELOCITY OF WATER IN METRES PER SECOND

LPM	INSIDE DIAMETER OF PIPE (MM)					
	20	25	32	40	50	63
25	1.33	0.85	0.52	0.33	0.21	0.13
50	2.65	1.70	1.04	0.66	0.042	0.27
75	3.98	2.55	1.55	0.99	0.064	0.40
100	5.30	3.39	2.07	1.33	0.85	0.53
150	7.95	5.09	3.11	1.99	1.27	0.80
200	10.60	6.79	4.14	2.65	1.70	1.07
250	13.26	8.48	5.18	3.31	2.12	1.34
300	15.91	10.18	6.21	3.98	2.55	1.60
350	18.58	11.88	7.25	4.64	2.97	1.87
400	21.21	13.57	8.28	5.30	3.39	2.14

*Recommended suction velocities in **BOLD**

UNITS OF FLOW

Litres Per Second	Litres Per Minute	Cubic Metres Per Hour	US Gallons Per Minute	Imperial Gallons Per Hour	Imperial Gallons Per Minute
1	60	3.6	15.85	702	13.2
0.017	1	0.06	0.264	13.2	0.22
0.278	16.667	1	4.4	220	3.666
0.063	3.785	0.227	1	50	0.833
0.00127	0.076	0.00454	0.02	1	0.0166
0.076	4.546	0.273	1.2	60	1



43SOUTH

Phone. 0800 654 112 | 03 349 1350

Email. orders@43south.co.nz | accounts@43south.co.nz

Christchurch

2/16 George Bellew Road
Dakota Park
Christchurch 8042

Auckland

Unit 2/13 Highbrook Drive
East Tamaki
Auckland 2013

Postal Address

PO Box 90
Tai Tapu 7645

Web. 43south.co.nz

Price List effective as at 1/5/2024

43South reserves the right to change prices, product specifications and products details without notice.
All product images are for reference purposes only and may not represent actual and/or current product.