



MaxQ High Performance Orbital Shakers*

Model SHKE416HP and SHKE430HP Series

Operating and Maintenance Manual 7020416 Rev. 2

Visit us online to register your warranty
www.thermoscientific.com/labwarranty

Thermo
SCIENTIFIC

* Triple counter-balanced, single eccentric drive mechanism (U. S. Patent #5,558,437)

* Test tube rack (U. S. Patent #5,632,388)

Warning Use the MaxQ High Performance Orbital Shakers to process non-flammable materials only. ▲

Caution Grounding circuit continuity is vital for the safe operation of this shaker. Never operate the unit with the grounding conductor disconnected. ▲

MANUAL NUMBER 7020416

2	40314	7/7/15	Added models SHKE416-1CE, SHKE430-1CE - 230V units	ccs
1	40139	4/15/15	Updated warranty information	ccs
0	28036/OS-751	9/8/14	Release 7	ccs
REV	ECR/ECN	DATE	DESCRIPTION	By



Important Read this instruction manual. Failure to read, understand and follow the instructions in this manual may result in damage to the unit, injury to operating personnel, and poor equipment performance. ▲

Caution All internal adjustments and maintenance must be performed by qualified service personnel. ▲

Material in this manual is for information purposes only. The contents and the product it describes are subject to change without notice. Thermo Fisher Scientific makes no representations or warranties with respect to this manual. In no event shall Thermo be held liable for any damages, direct or incidental, arising out of or related to the use of this manual.

©2014 Thermo Fisher Scientific. All rights reserved.



Important operating and/or maintenance instructions. Read the accompanying text carefully.



Potential electrical hazards. Only qualified persons should perform procedures associated with this symbol.



Equipment being maintained or serviced must be turned off and locked off to prevent possible injury.



Marking of electrical and electronic equipment, which applies to electrical and electronic equipment falling under the Directive 2002/96/EC (WEEE) and the equipment that has been put on the market after 13 August 2005.



This product is required to comply with the European Union's Waste Electrical & Electronic Equipment (WEEE) Directive 2002/96/EC. It is marked with the WEEE symbol. Thermo Fisher Scientific has contracted with one or more recycling/disposal companies in each EU Member State European Country, and this product should be disposed of or recycled through them. Further information on Thermo's compliance with this directive, the recyclers in your country and information on Thermo Scientific products will be available at www.thermoscientific.com.

- ✓ Always use the proper protective equipment (clothing, gloves, goggles, etc.)
- ✓ Always dissipate extreme cold or heat and wear protective clothing.
- ✓ Always follow good hygiene practices.
- ✓ Each individual is responsible for his or her own safety.

Do You Need Information or Assistance on Thermo Scientific Products?

If you do, please contact us 8:00 a.m. to 6:00 p.m. (Eastern Time) at:

1-740-373-4763

1-800-438-4851

1-877-213-8051

<http://www.thermoscientific.com>

service.led.marietta@thermofisher.com

www.unitylabservices.com

Direct

Toll Free, U.S. and Canada

FAX

Internet Worldwide Web Home Page

Tech Support Email Address

Certified Service Web Page

Our **Sales Support** staff can provide information on pricing and give you quotations. We can take your order and provide delivery information on major equipment items or make arrangements to have your local sales representative contact you. Our products are listed on the Internet and we can be contacted through our Internet home page.

Our **Service Support** staff can supply technical information about proper setup, operation or troubleshooting of your equipment. We can fill your needs for spare or replacement parts or provide you with on-site service. We can also provide you with a quotation on our Extended Warranty for your Thermo Scientific products.

Whatever Thermo Scientific products you need or use, we will be happy to discuss your applications. If you are experiencing technical problems, working together, we will help you locate the problem and, chances are, correct it yourself...over the telephone without a service call.

When more extensive service is necessary, we will assist you with direct factory trained technicians or a qualified service organization for on-the-spot repair. If your service need is covered by the warranty, we will arrange for the unit to be repaired at our expense and to your satisfaction.

Regardless of your needs, our professional telephone technicians are available to assist you Monday through Friday from 8:00 a.m. to 6:00 p.m. Eastern Time. Please contact us by telephone or fax. If you wish to write, our mailing address is:

Thermo Fisher Scientific
401 Millcreek Road, Box 649
Marietta, OH 45750

International customers, please contact your local Thermo Scientific distributor.

Table of Contents

Section 1	Installation and Start-Up	1-1
	Removing Pallet Shipping Brackets	1-1
	Location	1-2
	Install the Platform	1-2
	Removing Shipping Bracket	1-2
	Installing the Platform	1-3
	Electrical Requirements	1-5
	Assembling the Flask Clips	1-5
	Installing the Flask Clips	1-6
	Installing the Test Tubes Holders	1-8
	RS-232 Interface Connector	1-9
	Connecting the Remote Alarm	1-11
Section 2	Operation	2-1
	Control Panel Operation	2-2
	Factory (Default) Settings	2-3
	Change Shaker Speed & Time Settings	2-4
	Changing the RPM	2-4
	Changing Time	2-4
	Changing from Hold to Countdown	2-5
	Shaker Alarms	2-6
	Cycle Complete	2-6
	Power Failure	2-7
	RPM Tracking	2-7
	Check Belt	2-7
	Platform Stalled	2-8
	Check Fuse	2-8
	Turning Audible Alarm Off and On	2-8
	Calibrating the Shaker Speed	2-10
	Setting the Remote Alarms	2-11
	Cycle Complete	2-11
	Power Failure	2-12
	RPM Tracking	2-12
	Check Belt	2-12
	Viewing Total Operating Hours	2-12
	Software Version	2-13

Section 3	Maintenance	3-1
	Cleaning a Spill	3-1
Section 4	Service	4-1
	Alarms and Alarm Conditions	4-1
	General Fault Conditions	4-2
	Adjusting Drive V-Belt Tension	4-2
	Installing a New Drive V-Belt	4-3
	Spare Fuses	4-4
	Cleaning Inside the Cabinet (Major Spill)	4-4
Section 5	Specifications	5-1
Section 6	Parts	6-1
Section 7	Electrical Schematics	7-1
Section 8	Warranty	8-1

Section 1 Installation and Start-Up

The MaxQ High Performance Orbital Shakers are supplied with the following materials:

- 1 - T-handle 5/32" hex socket wrench
- 2 - Platform alignment studs 1/4-20
- 6 - Grade 8, 5/32" hex socket flat head screws (provided w/ platform)
- 1 - Screwdriver for flask clip installation and removal
- 1 - Line cord set

Warning This shaker is heavy! The weight of this shaker is 138 lbs. (62.7kg). Place this unit on a support surface which will accommodate the weight and operating motion of this shaker. Have assistance available when moving it. ▲

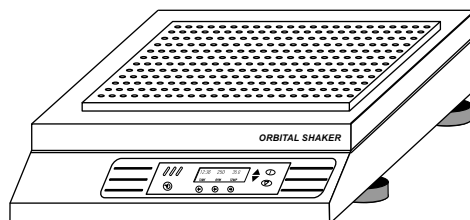

Figure 1-1. Front View

Removing Pallet Shipping Brackets

The Orbital Shaker is secured to its shipping pallet with two brackets, one on each side of the frame. Remove these brackets when the unit is unpacked by unhooking them from the shaker frame.

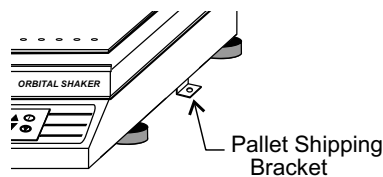

Figure 1-2. Pallet Shipping Bracket

Location

Install the shaker on a sturdy table or bench. The support structure must be able to accommodate both the weight and operating motion of the shaker. The shaker can also be placed under a bench or in a “knee well.”

Install the Platform

Note If your platform is already installed, skip this section and continue to next section. ▲

Caution Remove the shipping bracket and install the shaker platform before plugging in or attempting to operate the unit. ▲

After removing the orbital mechanism shipping bracket and installing the platform, remove this protective decal from the control panel to begin shaker operation.

IMPORTANT USER INFORMATION

WARNING: DO NOT START SHAKER W/O FIRST REMOVING THE PLATFORM HOLD DOWN BRACKET AND INSTALLING THE PLATFORM.

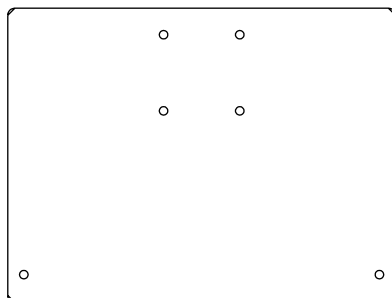

Figure 1-3. Orbital Mechanism Shipping Bracket

Removing Shipping Bracket

To protect the shaker’s orbital mechanism during shipment, a sheet metal shipping bracket is installed and must be removed before the unit can be operated. Using a 7/16” and 9/16” hex wrench, remove the three 1/4” and the single 3/8” screws. Retain this hardware for future shipping.

Installing the Platform

The Model 416 shaker accommodates either a 5/16" heavy-duty, 18" x 18" platform or an 18" x 24" platform. The Model 430, in addition to these platforms, also accommodates the 24" x 36" platform.

Note If installing the 18" x 24" platform on the Model 416, RPM is limited to 400. If installing the 24" x 36" platform on the Model 430, the 194012 counterweight kit must also be installed (by qualified service personnel). ▲

All shaker platforms are attached to their orbital mechanisms with six 1/4-20 hex socket flat head screws. These screws are hardened and should not be exchanged with any other screw type. The 5/32" hex socket wrench included with the shaker must be used when attaching the platform. Refer to Figure 1-4.

Caution Do not attempt to use a Phillips head screwdriver. ▲

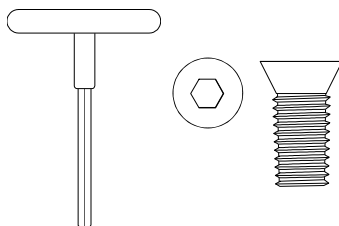

Figure 1-4. T-Handle Wrench and Hex Socket Head Screw

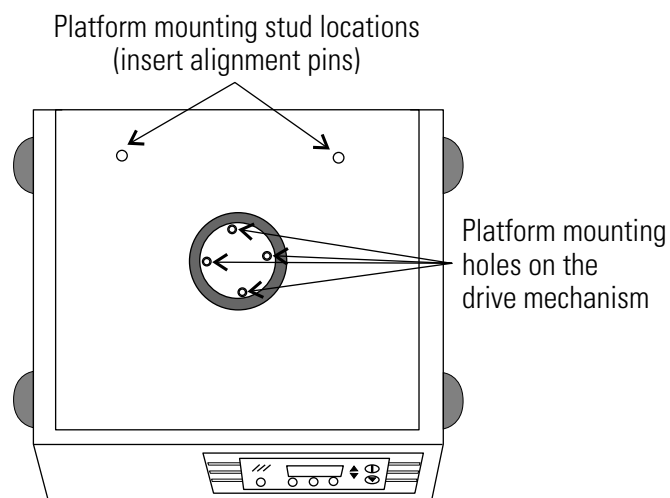

Figure 1-5. Platform Mounting Holes and Alignment Pin

Installing the Platform (continued)

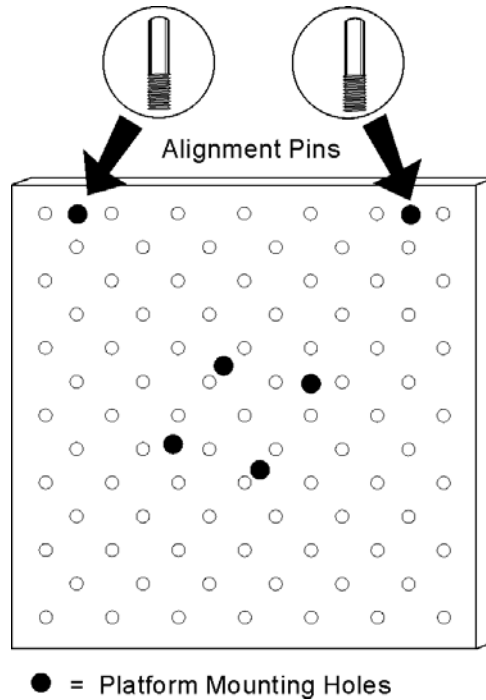

Figure 1-6. Platform Mounting Hole Locations

1. Insert the two 1/4-20 alignment pins into the two mounting holes identified in Figures 1-5 and 1-6.
2. Rotate the drive mechanism until the four mounting holes generally match the holes in the platform.
3. Place the platform onto the shaker and over the alignment pins.
4. Move the platform in an orbital motion until one or more of the center mounting holes are located.
5. Insert the hex socket head screws as the four holes are located. Do not tighten the screws.
6. Remove the 1/4-20 alignment pins and replace them with the remaining two hex socket screws.
7. Tighten all screws using the T-handle wrench.

Caution Use only the hex socket flat screws to fasten the platform, and only the T-handle wrench to tighten the screws. Torque these screws to 10 ft/lbs. ▲

Electrical Requirements

The electrical power requirements of the shakers are:

115 VAC, 50/60 Hz, 1 PH, 1.25 FLA

230 VAC, 50/60 Hz, 1PH, .65 FLA

Because these Orbital Shakers operate at a wide range of voltages, the electrical line cord is not permanently wired to the unit. Instead, a line cord receptacle is provided which accepts power cords for 115 or 230 volts. A voltage selector switch is located on the rear panel of the shaker adjacent to the line cord receptacle. Set the switch for the voltage in use at the laboratory site, using a small flatblade screwdriver. Refer to the illustration below, and to Figure 1-16.

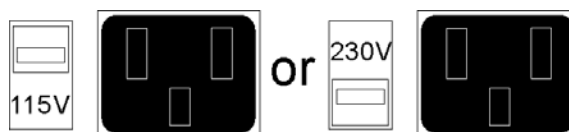

Figure 1-7. Voltage Selector Switch

Caution Before plugging in the shaker, verify that the voltage select switch is set for the electrical service available. ▲

The electric power switch (mains disconnect) is located on the lower front corner of the left side panel.

Assembling the Flask Clips

Each Flask Clip up to 6.0 liters in size comes with a metal spring which must be installed onto the clip. For flask clips through 500 ml, insert the end of each spring into the holes on the top of the clip leg as shown in Figures 1-8 and 1-9.

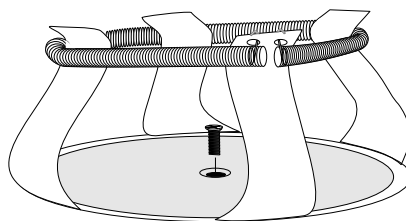

Figure 1-8. 250/300ml flask w/ cushion pad

Figure 1-9. One screw flask clip assy

Assembling the Flask Clips (continued)

The 2 L, 2.8 L, 4 liter, 5 L, and 6 L Flask Clips use two metal springs and rubber spring tubes. On these larger clips, the springs are installed by hooking their ends together as illustrated in Figure 1-10. The upper spring and spring tubes should be installed prior to mounting the clip to the platform. The lower spring and spring tubes, however, are placed around the bottom of the clip legs after the flask clip is fastened to the platform.

Note that the rubber spring tubes are placed between the clip legs.

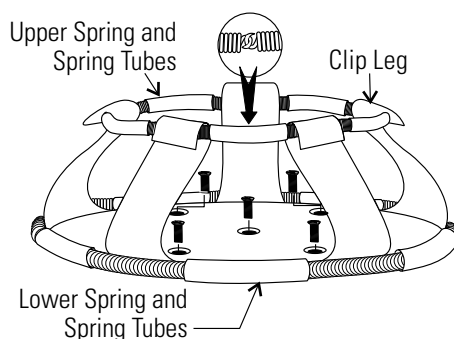

Figure 1-10. Clips for Flasks 2 Liter or Larger

The 2L, 2.8L, 4L, 5L and 6L clips are supplied with two sets of springs and rubber tubes.

Installing the Flask Clips

The SHKE416HP Shaker will accommodate glassware in numbers and sizes from forty-nine 25 ml flasks to two 6 liter flasks. The SHKE430HP Shaker will hold numbers and sizes from ninety-one 25 ml flasks to four 6 liter flasks. Refer to Tables 1-1, 1-2, and 1-3 for sizes and quantities.

All platforms have mounting holes for flask clips and test tube racks made by other manufacturers.

Flask clips can be attached anywhere on the shaker platform. The counter-balanced design of these shakers accommodates even an unbalanced load. The flask clips are supplied with the proper screws and are attached to the platform with a standard Phillips screwdriver or with the screwdriver provided with the unit.

Note that 1, 2, 2.8, 4, 5, and 6 liter flask clips use five screws. The 250/300 flask clip has an adhesive-backed flask cushion pad which is installed on the flat base of the clip body. A hole is provided in the pad for the mounting screw. Refer to Figure 1-8.

Installing the Flask Clips (continued)

Table 1-1. SHKE416HP Dedicated Shaker Platform Flask Clip Capacity

Dedicated platform number	No. of Clips	Flask Size	Springs per Clip	Screws per Clip
238010	49	25ml	1	1
238011	49	50ml	1	1
238012	25	125ml	1	1
238013	18	250/300ml	1 w/ lg pad	1
238014	16	500ml	1	1
238015	8	1l	1	5
238016	5	2l	2 w/10 tubes	5

Table 1-2. SHKE430HP Dedicated Shaker Platform Flask Clip Capacity

Dedicated platform number	No. of Clips	Flask Size	Springs per Clip	Screws per Clip
238017	91	25ml	1	1
238018	91	50ml	1	1
238019	40	125ml	1	1
238020	40	250/300ml	1 w/ lg pad	1
238021	24	500ml	1	1
238022	15	1l	1	5
238023	12	2l	1	5
238024	6	4l	2 w/10 tubes	5
238025	4	6l	2 w/12 tubes	5
238026	6	2.8l	2 w/10 tubes	5

Table 1-3. SHKE430HP Universal Platform

Quantity	Flask Size
150	25ml
150	50ml
75	125ml
70	250/300ml
30	500ml
24	1l
15	2l
11	4l
8	5l
8	6l
11	2.8l
31	Microplates*

* Microplates can be stacked for greater capacity

Installing the Test Tubes Holders

The Accessory Test Tube Racks and Test Tube Rack Holders are available in four sizes and are listed in Table 1-4. All of the Test Tube Rack Holders are adjustable in seven positions, swinging and locking at 15°, 30° and 45° in either direction. Figure 1-11 illustrates the Test Tube Rack Holder with the rack in place.

To remove the rack, spread the metal tabs on either end of the holder and lift out the plastic Test Tube Rack.

To install the Test Tube Rack Holder onto the shaker platform, remove the rack and rotate the swing-bed of the holder 90° by pulling the knobs of the locking pins on either end of the holder outward. The pins are locked outward by turning the knob 1/4-turn (Figure 1-12).

Align any of the holes in the bottom of the rack holder with the threaded holes in the platform. Secure the holder with the screws provided.

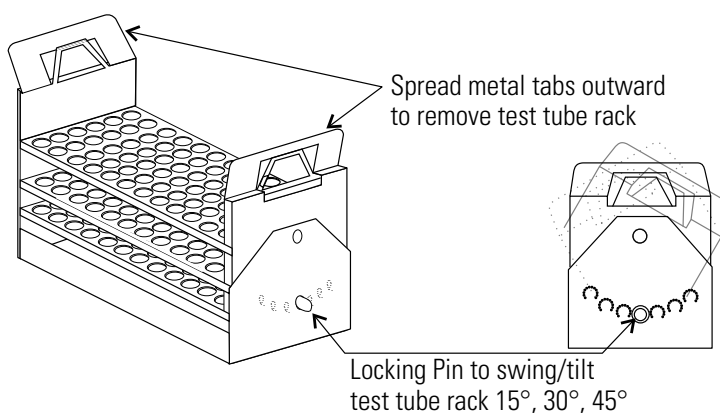

Figure 1-11. Test Tube Rack w/ swing/tilt mechanism

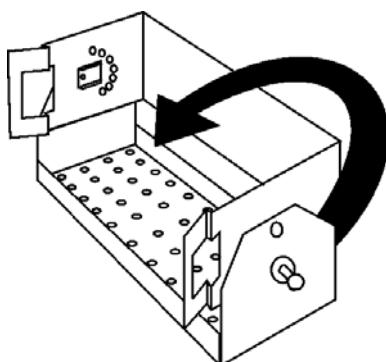

Figure 1-12. Test Tube Rack Holder w/ rack removed and bed rotated 90°

Table 1-4. Test Tube Racks and Adjustable-Angle Test Tube Rack Holders

Part Number	Description
950040	Test tube rack 10-13mm size
950060	Test tube rack 16-20mm size
600074	Test tube rack 21-25mm size
600075	Test tube rack 26-33mm size
600076	Adjustable-angle test tube rack holder w/rack 10-13mm
600077	Adjustable-angle test tube holder w/rack 16-20mm
600078	Adjustable-angle test tube holder w/rack 21-25mm
600079	Adjustable-angle test tube holder w/rack 26-30mm
600089	2 tier microplate rack
600090	3 tier microplate rack
194024	#10-24 Pan head Phillips screws for mounting test tube holders to Thermo orbital shaker platforms
185062	Pan head Phillips screws, washers and nuts for mounting test tube holders to Thermo 2568 and 2569 shaker baths

RS-232 Interface Connector

The MaxQ High Performance Orbital Shaker is equipped with an RS-232 Serial Communication Interface for the remote transmission of data. An RJ-11 telephone style connector is located on the rear of the shaker. Refer to Figure 1-14.

The data is “dumb terminal” formatted, which permits connecting to a computer or a serial printer.

Three wires are used for the RS-232 interface:

1. Transmit data (/TXD) - pin 2 DB-25 connections
2. Receive data (/RXD) - pin 3 “
3. Signal ground (GND) - pin 7 “

The data format is:

Baud 1200 (9600 baud w/ jumper at J2 on Main Control Board)
 Data bits 8 (7 bit ASCII with leading zero)
 Start bits 1
 Stop bits 1
 Parity none

RS-232 Interface Connector (cont.)

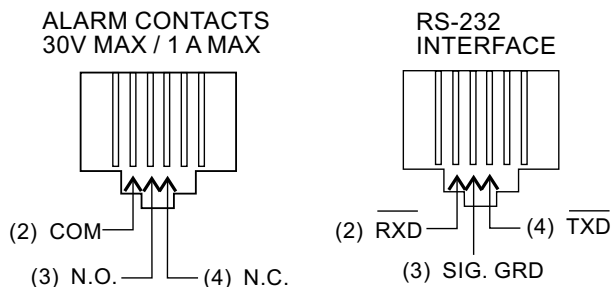

Figure 1-13. RS-232 and Remote Alarm Connectors

The data transfer sequence is transmitted in the following format. X refers to the numerical temperature (if the temperature option is installed) or RPM.

(NUL)XX.XX(H)(SP)(SP)XXXRPM(SP)(SP)XX.XC(SP)(LF)(CR)(EOT)

- NULNull character (0)
- SPSpace
- LFLine feed
- CRCarriage return
- EOTEnd of text (4)
- HHold Mode

The MaxQ Shaker transmits time, temperature and RPM data one minute after power is first applied, then every 60 minutes.

The shaker's microprocessor responds to two ASCII commands from the remote: <CNTL> <Q> (XON), and <CNTL> <S> (XOFF).

<CNTL> Q

The shaker will transmit time, temperature (if the temperature option is installed*) and RPM data upon receiving <CNTL> <Q> (XON) and will restart 60 minute interval transmissions if they had been inhibited by a <CNTL> <S> (XOFF).

<CNTL> S

Receiving a <CNTL> <S> (XOFF) from the remote inhibits the shaker from sending serial data indefinitely until a <CNTL> <Q> (XON) is received.

Connecting the Remote Alarm

An internal, remote alarm SPDT relay is provided to monitor alarms and is connected by an RJ-11 (telephone style) jack located on the rear of the cabinet. The relay provides NO (normally open) and NC (normally closed) output and may be wired to a central remote alarm location or to an independent alarm system.

IMPORTANT USER INFORMATION

CAUTION! Stored product should be protected by a redundant 24 hour/day monitoring system with alarm capability. An interconnect jack and thermocouple are installed for centralized monitoring, should on-board system fail.

A modular to modular cable (Stock No. 190388) and an RJ-11 telephone style terminal converter (Stock No. 190392) or equivalent may be used to convert the remote alarm output to a screw terminal connection. Refer to Figures 1-14 and 1-15.

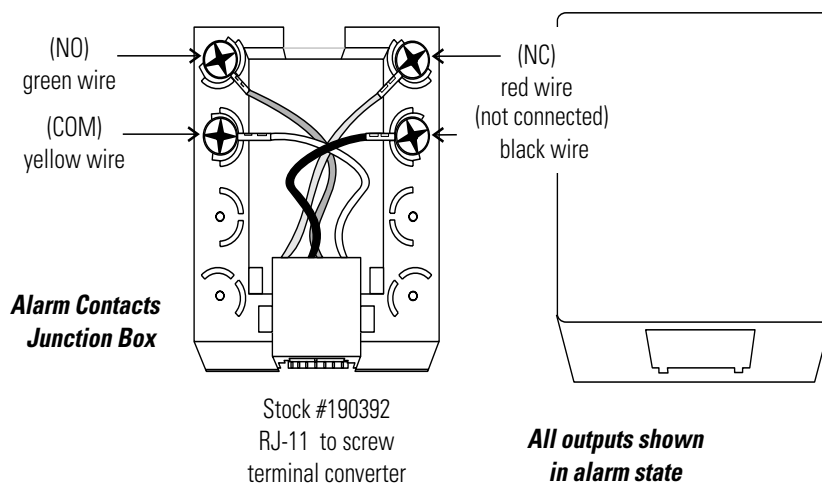

Figure 1-14. Outputs

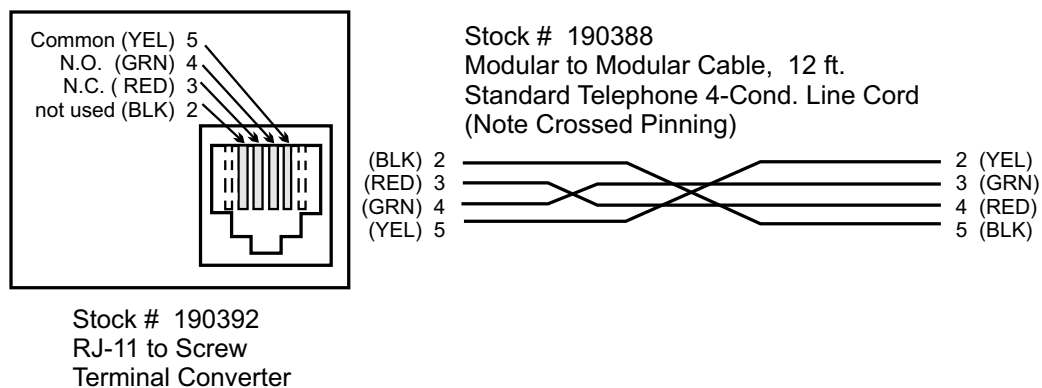

Figure 1-15. Pin Contacts

Connecting the Remote Alarm (cont.)

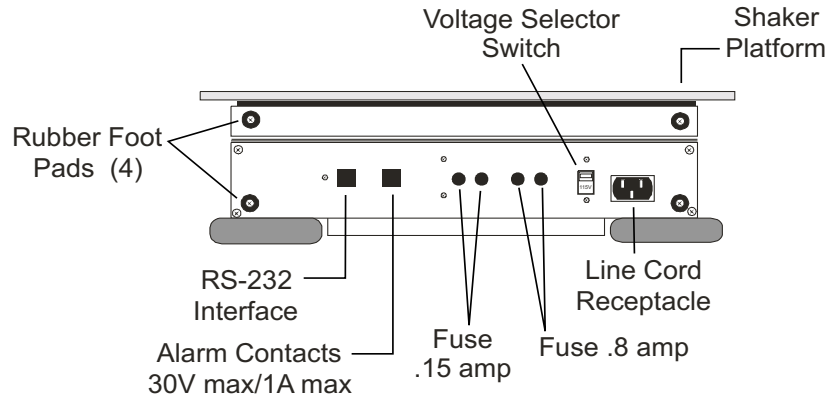

Figure 1-16. Remote Alarm Connector on Rear Panel

Section 2 Operation

The SHKE416HP and SHKE430HP are microprocessor-controlled tabletop orbital shakers designed to accommodate a wide variety of flasks, test tubes and other glassware. The control system, common for each, is easily programmed and stores the user-defined time and speed settings which remain in memory even when the shaker is turned off and unplugged.

The computer-based speed controller continuously adjusts for line voltage fluctuations and provides smooth start-ups and consistent RPM control. The circuitry is designed to slowly bring the platform up to speed and down to a stop to prevent liquid splashing from flasks or test tubes.

Warning The microprocessor speed control system may take up to one minute to bring the platform up to speed. Never leave the shaker unattended when starting it. Make sure all flasks and test tube racks are firmly seated in the clips and check the security of the flask clip and platform attachment screws weekly. ▲

Control Panel Operation

The shaker control panel has a liquid crystal display and eight operating keys or buttons which are identified by word and symbol. During programming activities, the up and down arrows increase and decrease the numerical values of time or platform speed. Pressing and holding either arrow will cause the values to scroll in that direction. Pressing and holding for about five seconds will increase the scrolling speed.

When programming the system configuration, the UP arrow returns the display to the system's Operating Screen showing the Time, RPM and Temperature, while the DOWN arrow advances the display to the next programming screen.

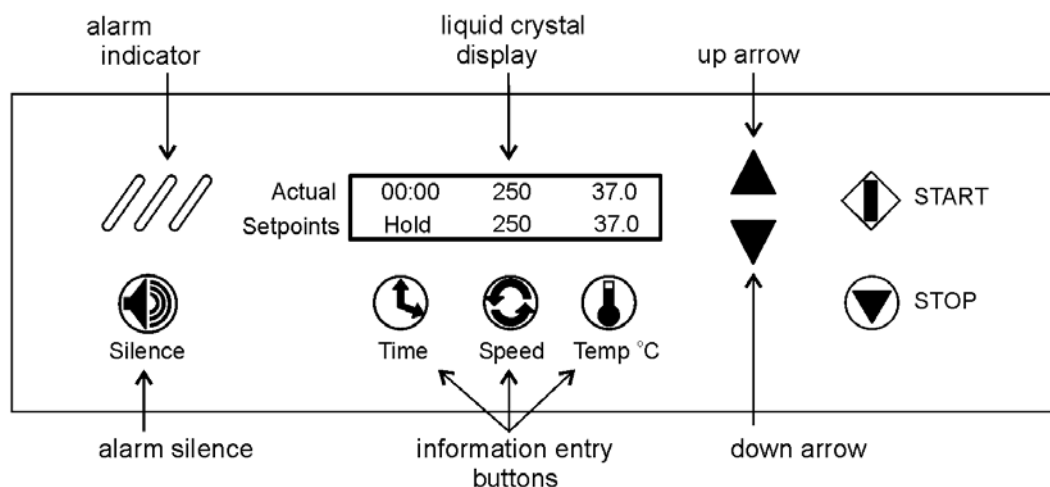

Figure 2-1. Control Panel Components

The alarm indicator and alarm silence button complete the shaker control panel. When in alarm, the unit sounds an audible warning and flashes the three red indicators. Pressing the Silence button turns off the audible portion of the alarm. However, the three flashing indicators continue to flash until the alarm condition is corrected. The audible warning will sound again in about fifteen minutes if the condition continues.

The alarm features are discussed in detail in the configuration section of this manual.

Quick Start-Up

The MaxQ Orbital Shaker may be operated as soon as the platform is installed and the unit is plugged in and turned on.

Note At power up, the screen at the right will appear briefly. ▲

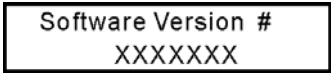

Pressing Start and Stop will operate the shaker at the factory settings shown in Figure 3-1. When starting, the Actual numbers along the top of the liquid crystal display will differ from the Setpoint values shown along the bottom. These numbers will change as the unit begins to operate.

Time - With the time set at Hold, the time display in the upper left portion of the screen will begin to count upward, showing the total operating hours and minutes. The system will reset to 00:00 whenever the unit is stopped and restarted, using the Stop and Start buttons. The unit will not reset if the unit is turned off and on using the power switch.

Speed - The Actual speed will display zero RPM's and will gradually rise as the platform begins its motion.

Temperature - If the optional temperature monitoring kit is installed, the temperature will be displayed in the upper right portion of the liquid crystal display.

The values shown in Figure 2-1 are set at the factory and are considered default values. Other factory settings are shown in the table following.

Factory (Default) Settings

- Function Default
- Audible Alarm ON
- RPM Tracking Limit (fixed) 5
- All Remote Alarms ON

To get the most from the shaker's microprocessor-based technology, the Models 416/430 can be easily programmed to meet the most demanding laboratory requirements. The following sections outline the procedures for changing the settings and for programming the shaker control system.

Change Shaker Speed & Time Settings

When first turned on or when the shaker is operating, Time, RPM, and Temperature (if the monitoring kit is installed) values are displayed on the LCD. A typical screen is illustrated in Figure 2-1. For convenience, this is called the Operating Screen throughout this operating manual. All programming or setting changes start from this screen.

The instructions to program the SHKE416HP and SHKE430HP are written in a step-by-step format. These instructions begin and end at the Operating Screen.

Caution At any time during programming or changing settings, if no control panel buttons are pressed for about fifteen seconds, the display automatically returns to the Operating Screen, storing any settings made. New settings are also stored immediately when an arrow key is pressed. ▲

Changing the RPM

1. Press the button beneath the Speed setpoint. The RPM value will begin to flash.
2. Press the up or down arrows to set the new speed in 1 RPM increments. Hold either button to scroll.
3. Press the Speed button again to return to the Operating Screen.

Changing Time

The MaxQ SHKE416HP and SHKE430HP manage operating time in two ways:

Hold - When Time is set to Hold, the value shown in the Actual portion of the display represents total operating time and may be reset at the operator's convenience. The shaker will continue to count upwards even if it has been repeatedly turned off and on with the power switch. The Time will, however, reset to 00:00 when the Stop button is pressed, then the unit restarted by pressing the Start button.

Countdown - When in the countdown mode, the shaker will operate for the set period and automatically shut down. The display will show the total time in the Setpoint segment and the operating time remaining in the Actual part of the display, as the microprocessor counts down to zero.

Changing from Hold to Countdown

1. Press the button beneath the Time setpoint. Hold will begin to flash.

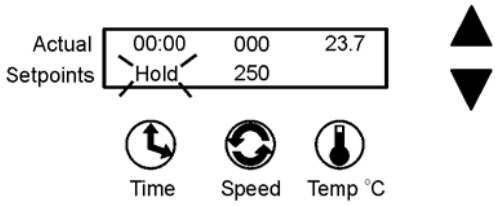

2. Press either arrow to access the Countdown Time setpoint. The preset time setpoint will begin to flash.

3. Press the up or down arrows to set the desired operating time in five minute increments. Hold either arrow to scroll in that direction.

4. When the desired elapsed time is set (6 hours, 30 minutes in this example), press the Time button to return to the Operating Screen.

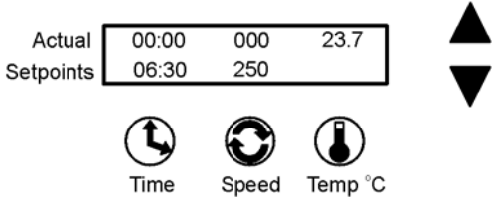

Pressing the Start button will start the shaker and begin the countdown sequence. When 00:00 is reached, the shaker will automatically shut off and the Cycle Complete alarm will sound. As shown in the illustration below, the shaker is up to speed (250 RPM) and the countdown is underway. If not interrupted, the shaker will stop in 5 hours, 35 minutes, and the Cycle Complete alarm will sound. Refer to this alarm on the following page.

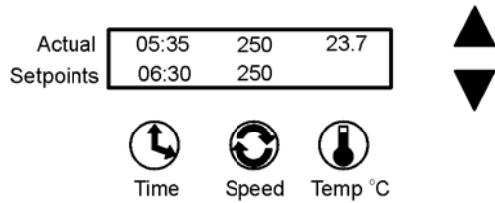

Shaker Alarms

The SHKE416HP and SHKE430HP Orbital Shaker control system monitors and provides alarms for six operating parameters.

Parameter	Alarm Message
Cycle Status	Cycle Complete
Loss of Input Power	Power Failure
RPM versus Setpoint	RPM Tracking
Drive Belt Integrity	Check Belt
Platform Movement Status	Platform Stalled
Motor Fuse Integrity	Check Fuse

Both audible and visual alarm warnings for these six parameters are provided by the Orbital Shaker. Visual flashing of the three diagonal indicator lights on the control panel, a progression of text messages on the display, and an audible tone alerts the operator that an alarm condition has occurred, or currently exists. For convenience, the audible tone is silenced by pressing the Silence button, but will ring back in about 15 minutes. However, the alarm warning indicator lights and alarm messages continue until the alarm condition is corrected by the operator. Then, pressing the Silence button clears the message from the display. (The Check Belt and Check Fuse alarm messages clear when power to the unit is cycled OFF, then ON.) As discussed in the Configuration Section of this manual, the audible alarm feature may be turned off to suit operator or laboratory needs. Refer also to the alarms and corrective actions chart in the Service section of this manual.

Cycle Complete

Cycle Complete alerts the operator that the end of the countdown running time has been reached.

The Cycle Complete message shown will be displayed and the shaker will stop.

Actual	00:00	00	37.0
Setpoints	Cycle Complete		

Pressing the Silence button clears the message from the display screen.

Power Failure

Power Failure alerts the operator that electrical power to the shaker has been interrupted, then restored while it was shaking. While the system will return to normal operation when power is restored, the alarm message will remain and the audible tone will continue to sound to alert the operator. Both the display message and the audible tone are cleared by pressing the Silence button.

Actual	00:00	00	37.0
Setpoints	Power Failure		

Note The alarm will not occur if the power failure is less than 15 seconds in duration. ▲

If power is interrupted for two hours or more while the Shaker is turned on but not shaking, a Power Fail alarm will occur. The purpose of the alarm in this case is to alert the user that an extended duration power failure occurred during the Hold interval after a timed shaking operation, or during a period of incubation only. This alarm will also occur any time the Shaker is turned on after an extended off period greater than 2 hours (such as when the unit is shipped from the factory, or when it is returned to use after a period of storage).

RPM Tracking

RPM Tracking alerts the operator by either alarm message shown at the right that the platform speed has varied ± 5 RPM.

Actual	08:41	255	37.0
Setpoints	RPM is High		

Actual	08:41	245	37.0
Setpoints	RPM is Low		

Note A two-minute alarm delay is built into software. ▲

In the alarm state, the audible alarm is silenced by pressing the Silence button, but will ring back in about 15 minutes. The screen message and warning lights, however, will continue until the fault is corrected. Then, the alarm message is cleared by pressing the Silence button.

Check Belt

Check Belt alerts the operator that the drive belt may have broken or something is slowing or preventing platform movement. In the alarm state, the audible alarm is silenced by pressing the Silence button, but will ring back in about 30 minutes. The screen message and warning lights, however, will continue until the fault is corrected. Then, the alarm message is cleared by cycling power to the unit OFF, then ON.

Actual	08:41	00	37.0
Setpoints	Check Belt		

Platform Stalled

Platform Stalled alerts the operator that something is preventing free platform movement. The motor automatically shuts off and the audible alarm, screen message and warning lights are initiated. The motor will attempt restart after approximately 15-20 seconds. The motor will continue to cycle On and Off until the obstruction is removed or the unit is turned off. On motor restart, the audible alarm and warning lights are automatically cleared. The screen message remains until cleared by the operator.

Actual	08:41	0	23.7
Setpoints	Platform Stalled		

Check Fuse

Check Fuse alerts the operator that the primary drive motor fuse has blown. The audible alarm, screen message and warning lights are initiated. When the unit is turned on after fuse replacement, all alarm indicators are cleared.

Actual	08:41	0	23.7
Setpoints	Check Fuse		

Turning Audible Alarm Off and On

To access the system Configuration menu, press the down arrow, the up arrow and the Silence button in that sequence.

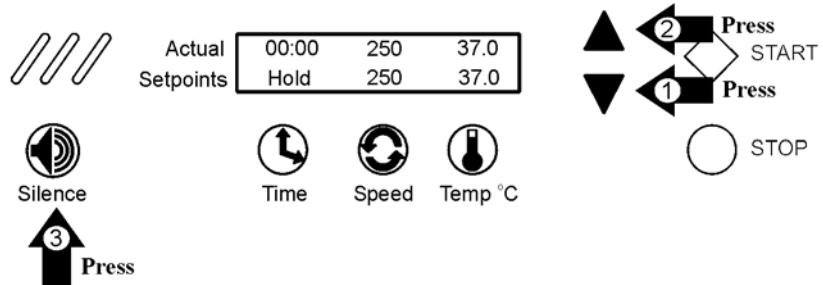

This screen will appear on the display.

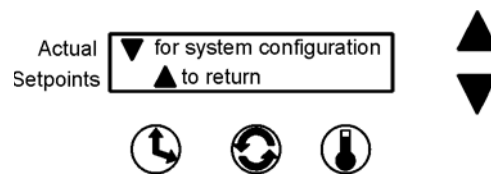

Turning Audible Alarm Off and On (cont.)

Pressing the down arrow continues with system configuration. Pressing the up arrow returns to the Operating Screen.

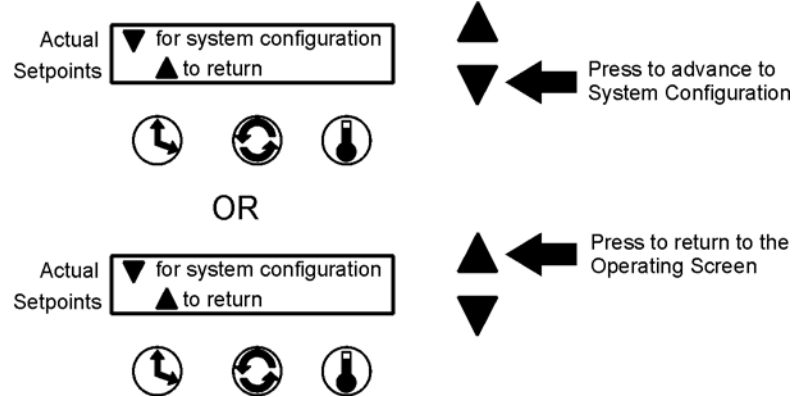

Caution During the following configuration, if no selection is made by pressing a button or arrow, the display will revert to the Operating Screen in about fifteen seconds. ▲

Begin by pressing the down arrow, the up arrow, and the Silence button. The screen shown below will appear on display.

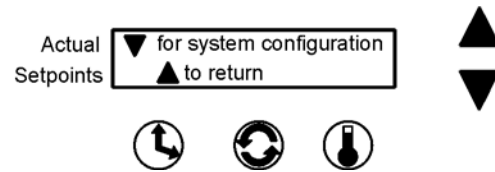
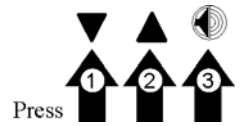

When this screen opens, press the down arrow once.

At this screen (below), press the Time button beneath Audible. The following screen will appear and the current setting will flash.

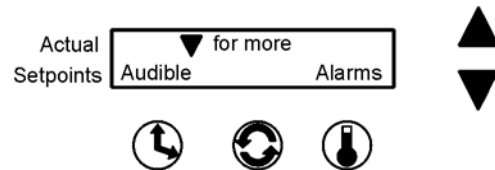

Press the up or down arrow to turn the audible alarm function on or off. Pressing any of the three buttons (Time Speed or Temp) will return the display to the previous screen. Not pressing anything for about fifteen seconds returns the display to the Operating Screen.

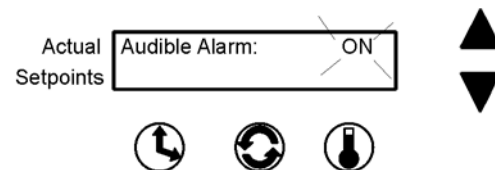

Turning Audible Alarm Off and On (cont.)

When the audible alarm is disabled, a warning message is placed in the Setpoint portion of the Operating Screen display as illustrated at the right.

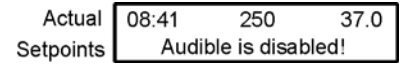

Calibrating the Shaker Speed

From the Operating screen, press the down arrow, up arrow and Silence button in that sequence (shown at the right) to open the configuration menu. From the screen below, press the down arrow twice to bring up the following screen.

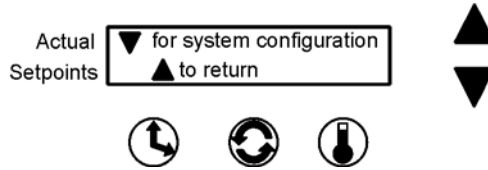
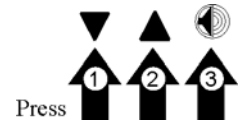

Press the Speed button beneath RPM.

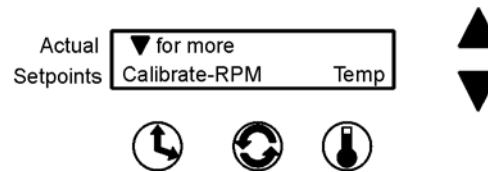

The value shown on the screen following is the present speed setpoint. Using the up and down arrows, increase or decrease the platform speed until the reading on an independent, accurate speed measuring device matches the shaker speed setpoint.

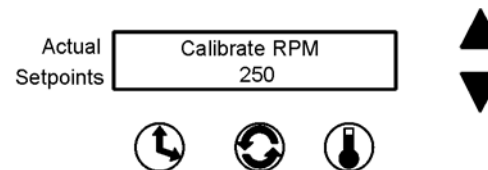

When finished, press the Speed button to save the setting. The display will return to the Calibrate - RPM Temp screen. Or, if nothing is pressed for about fifteen seconds, the display will revert to the Operating Screen and the setting will be automatically saved to memory.

Setting the Remote Alarms

The SHKE416HP and SHKE430HP Orbital Shaker control system monitors and provides alarms for six operating parameters:

Parameter	Alarm Message
Cycle Status	Cycle Complete
Loss of Input Power	Power Failure
RPM versus Setpoint	RPM Tracking
Drive Belt Integrity	Check Belt
Platform Movement Status	Platform Stalled
Motor Fuse Integrity	Check Fuse

These alarms can alert a remote alarm monitoring system through an internal SPDT relay connected to an RJ-11 jack on the rear of the shaker cabinet. Refer also to “Connecting the Remote Alarm” in this manual. Each of these alarms (except Platform Stalled and Check Fuse) may be independently turned on and off to suit operator or laboratory needs.

To set the remote alarms to ON or OFF, open the Remote Alarm Configuration menu by pressing the down arrow, up arrow, and Silence buttons in that sequence.

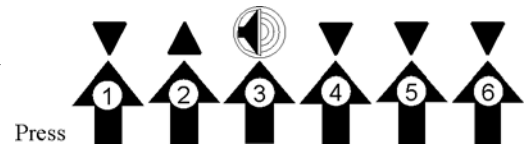

Then, press the down arrow three times until the screen below is showing.



Press Rmte (remote). The alarms will be shown in the following sequence:

Note If no buttons are pressed, the display will automatically return to the Operating Screen after about fifteen seconds, saving the selection to memory. ▲

Cycle Complete

Toggle the Cycle Complete alarm with either the up (ON) arrow or the down (OFF) arrow. Pressing the Next (temperature) button advances the display to the next alarm, saving the shown Cycle Complete setting to memory.

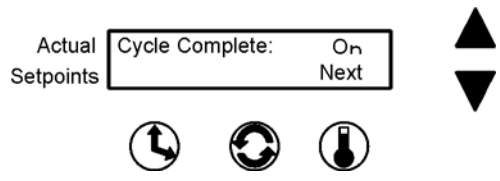

Power Failure

Toggle the Power Failure alarm with either the up (ON) arrow or the down (OFF) arrow. Pressing the Next (temperature) button advances the display to the next alarm, saving the Power Failure setting to memory.

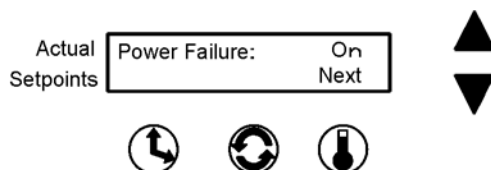

RPM Tracking

Toggle the RPM Tracking alarm with either the up (ON) arrow or the down (OFF) arrow. Pressing the Next (temperature) button advances the display to the next alarm, saving the RPM Tracking setting to memory.

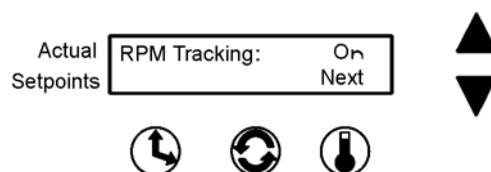

Check Belt

Toggle the Check Belt alarm with either the up (ON) or the down (OFF) arrow. Pressing the Next (temperature) button advances the display to the next alarm, saving the Check Belt setting to memory.

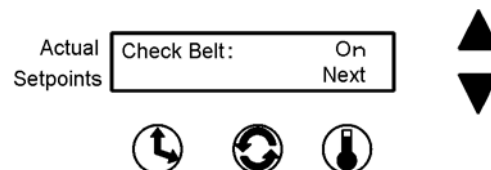

Viewing Total Operating Hours

Whether the shaker has been operated in the hold or countdown modes and/or has been turned off and unplugged many times, the microprocessor control system maintains a running total operating hours.

To view this information, access the Configuration menu by pressing the down and up arrows and the Silence button in sequence and pressing the down arrow three times.

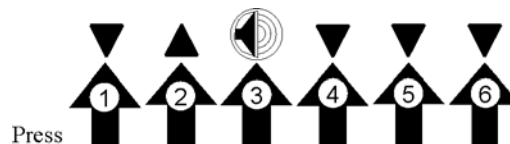

Viewing Total Operating Hours (cont.)



Pressing RunHrs shows the total accumulated run hours as displayed in the illustration below. In about fifteen seconds, the display will return to the Operating Screen.

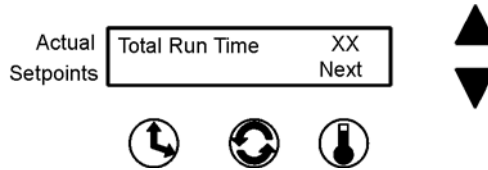

Software Version

Software Version is for factory use only and will be important if troubleshooting the microprocessor programming is ever necessary.

To access this screen, press the down arrow, the up arrow, the Silence button, and then the down arrow button four more times.

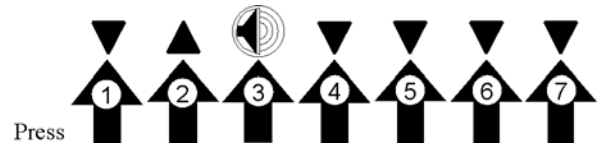

The screen below will appear on the display.

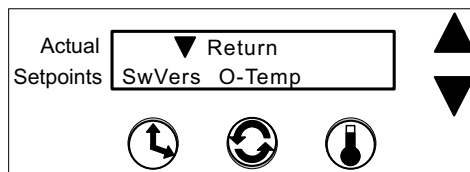

Press the Time button beneath SwVers and the screen at right will appear, showing the software version in the control system memory.

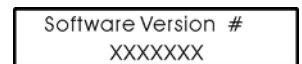

To return to the previous screen, press the Time button. To return to the Operating Screen, wait about fifteen seconds.

Menu Map

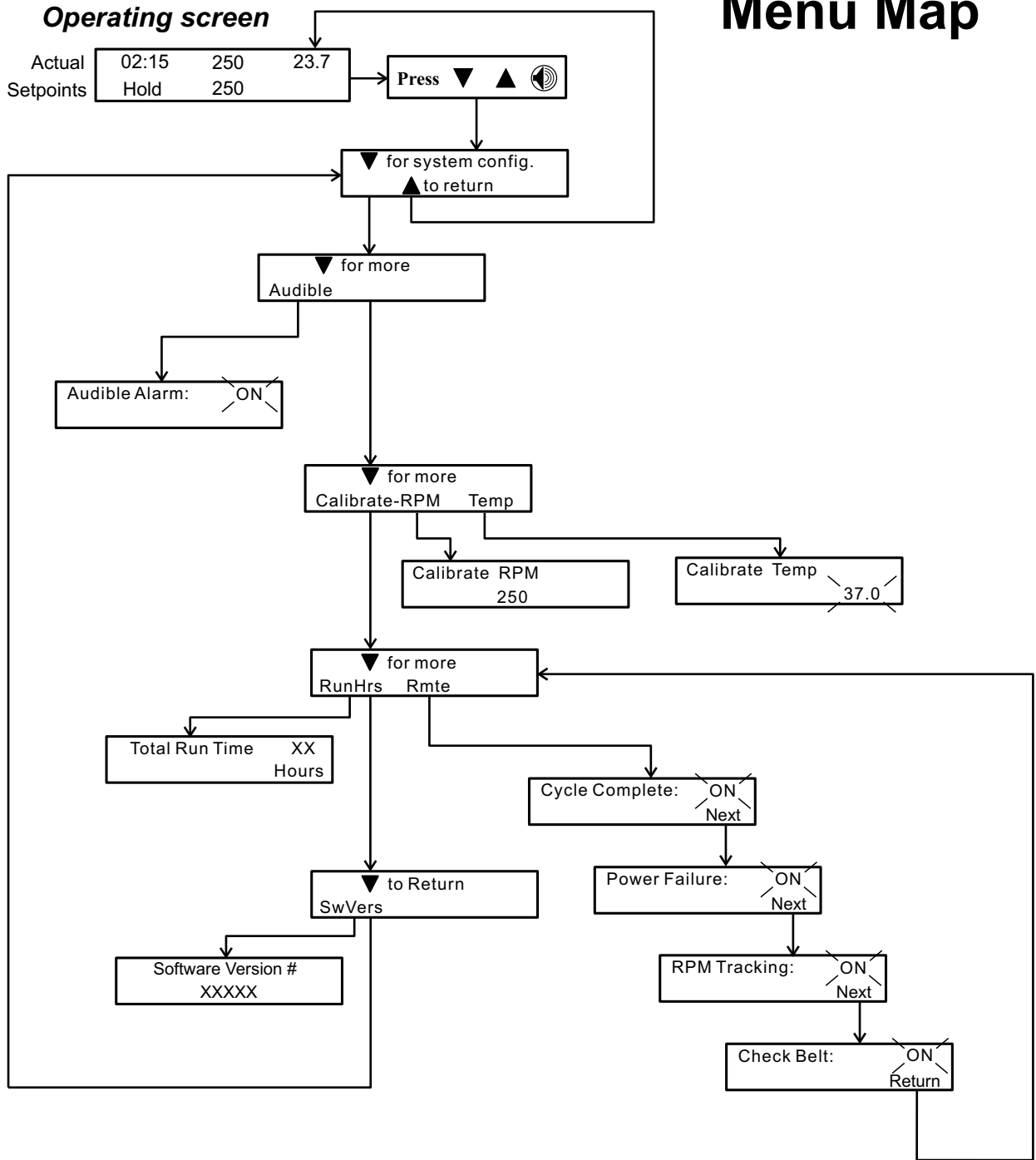

Note: Numerical values and alarm settings shown here are for reference only and may not match any specific shaker Also, map is shown with optional temperature probe installed

PREVENTIVE MAINTENANCE

Shakers

Your equipment has been thoroughly tested and calibrated before shipment. Regular preventive maintenance is important to keep your unit functioning properly. The operator should perform routine cleaning and maintenance on a regular basis. For maximum performance and efficiency, it is recommended the unit be checked and calibrated periodically by a qualified service technician.

The following is a condensed list of preventive maintenance requirements. See the specified section of the operating manual for further details.

We have qualified service technicians, using NIST traceable instruments, available in many areas. For more information on Preventive Maintenance or Extended Warranties, please contact Technical Services.

Cleaning and calibration adjustment intervals are dependent upon use, environmental conditions and accuracy required.

Tips for all shakers:

Use only our standard flat-head screws for flask clips.

Use only our standard round-head screws for test tube racks, holders and utility trays.

Preventive Maintenance for SHKE416HP/SHKE430HP Series Shakers

Refer to Manual Section	Action	Daily	Monthly	Yearly
--	Clean the unit with mild detergent and wipe dry as needed		✓	
--	Check under the platform for broken glass or other debris.		✓	
3	* Check and document calibration of temperature, alarms, speed and time, as applicable			✓

* *Qualified service technicians only*

Section 3 Maintenance

MaxQ Orbital Shakers use a brushless DC motor and oversized, permanently-lubricated bearings that require no maintenance.

The anodized brushed aluminum platform and powder-coated steel cabinet surfaces can be cleaned by wiping with a mild detergent and water. However, liquids should not be allowed to enter the shaker cabinet from under the platform. All spills should be cleaned up immediately. If necessary, remove the platform. Follow the cleaning procedures below. Refer to Section 1, “Installing the Platform”, of this manual when reinstalling the platform.

The microprocessor control panel uses sealed pushbuttons and a liquid crystal display, and may be cleaned by wiping with laboratory detergents and drying with a soft cloth.

Cleaning a Spill

If an accidental spill places liquids or other materials under the platform, immediately turn the unit off, unplug it, and remove the platform with the T-handle wrench supplied with the unit. Clean up the spill, following regular laboratory procedures.

Replace the platform following the procedures in Section 1.

Caution If the spill has entered the shaker cabinet through the operating mechanism opening beneath the platform, follow the “Major Spill Cleaning Procedure” in Section 4 of this manual. ▲

Section 4 Service

Warning The procedures outlined in this section must be performed by persons experienced in servicing and maintaining laboratory equipment. Lockout and tagout electrical power connections whenever removing cabinet panels or working on electrical or motor control components. ▲

With the exception of replacing the drive v-belt and six electrical fuses, the MaxQ Orbital Shakers contain no user-serviceable components. The following is a list of display messages, which may help diagnose abnormal conditions.

Alarms and Alarm Conditions

If the microprocessor control system senses a fault, malfunction or abnormal operating condition, alarm messages will appear on the liquid crystal display. These messages will be helpful should service or repair assistance be necessary.

Alarm Message	Fault Condition
RPM High	RPM tracking has sensed shaker speed higher than setting
RPM Low	RPM tracking has sensed shaker speed lower than setting
Power Failure	Power has failed during shaker operation
Cycle Complete	Notifies operator that the end of a countdown cycle has been reached
Check Belt	Motor V-belt has broken or is slipping
Audible is Disabled!	Continuous operator notification that audible alarm has been disabled
Platform Stalled	Free movement of the platform has been obstructed
Check Fuse	Primary drive motor fuse has blown

General Fault Conditions

Symptom	What to Check and Where to Look
Display is dark, shaker will not operate	Power at the wall outlet Fuses on the back of the unit are blown Power switch not turned on
Display is lit, motor will not operate	Voltage selector switch at wrong position Drive motor fuses inside cabinet are blown No time value entered into the system (Section 2) Time countdown has been reached (Section 2)
Display on, unit will not operate (Time reads zero)	Countdown time reached, reset the TIME (Section 2)

Adjusting Drive V-Belt Tension

Tools needed:

Phillips screwdriver

3/8" drive socket wrench with 7/16" socket

1. Remove all connectors and the line cord from the back of the shaker.
2. Lift the front of the shaker and rest it on its back. Remember that the weight of the shaker is 138 pounds (62.7kg).

Caution The shaker is not stable when lying on its back. A second person may be necessary to support the shaker while in this position. ▲

3. Remove the bottom cabinet cover (2 Phillips screws).
4. Loosen but do not remove, the two 7/16" screws located in the slotted holes adjacent to the shaker drive motor. Refer to Figure 4-1.
5. Loosen but do not remove, the 7/16" screw adjacent to the drive motor, which is not in a slotted hole. The drive motor pivots around this screw. Loosening all three screws allows internal springs to apply proper tension to the v-belt.
6. Tighten both screws in the slotted holes.

Adjusting Drive V-Belt Tension (continued)

7. Tighten the remaining drive motor pivot screw. The v-belt is now under proper operating tension.

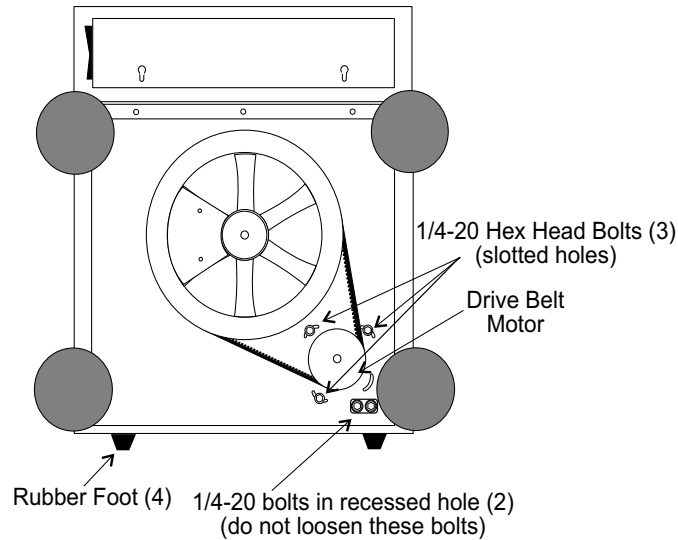

Figure 4-1. Underside of shaker cabinet with bottom cover removed

Caution Tighten all screws. Do not allow the shaker to operate against the spring tension. ▲

Installing a New Drive V-Belt

Refer to “Adjusting Drive V-Belt Tension” to loosen the three 7/16” drive motor retaining screws.

Caution The drive motor is under spring tension and may suddenly move when the pivot screw is loosened. When the new belt is installed, tighten all screws. Do not allow the shaker to operate against the spring tension. ▲

1. Place the new v-belt around the bottom of both the motor and the large drive wheel.
2. Force the drive motor inward toward the drive wheel and rotate the drive wheel counterclockwise, forcing the v-belt into the wheel groove. It may be necessary to use a lever (large screwdriver or pry bar) to move the drive motor inward against the spring tension. The large rubber foot can be used to pry against. Once the belt is properly seated in the motor and drive wheel, the internal springs apply proper tension.
3. Tighten the two screws in the slotted holes, then tighten the drive motor pivot screw.
4. Replace the bottom cover and return the shaker to service.

Spare Fuses

Four spare fuses are provided with this shaker and are taped to the underside of the control panel plastic frame. The plastic frame is attached to the cabinet by Velcro strips. The panel can be removed by grasping the corners and pulling it off. There are also small indents located along the edges of the panel, which accommodate a flat screwdriver blade.

The locations of the fuses are identified in Figure 1-16.

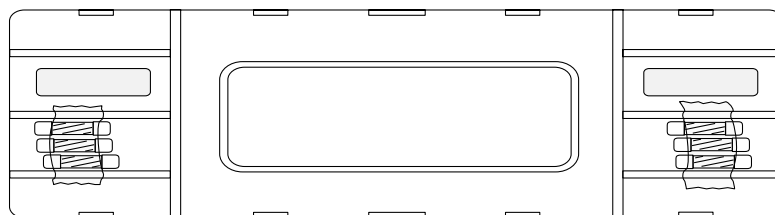

Figure 4-2. Underside of Frame

Cleaning Inside the Cabinet (Major Spill)

1. Make sure the unit is turned off, unplugged, and the line cord removed from the side of the cabinet. The platform should already be removed.
2. Remove the screws and lift off the cover plate. The mechanism will be accessible as shown in Figure 4-3.

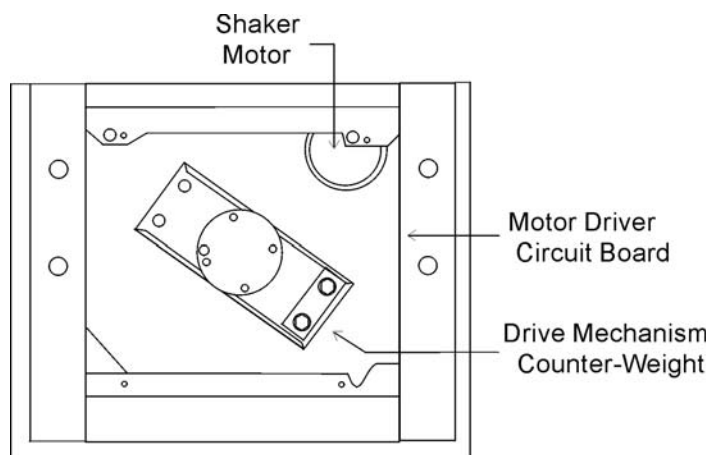

Figure 4-3. Behind Cover Plate

3. Clean the mechanism area with a 70% solution of alcohol. Everything must be cleaned with special attention given to the area around the motor.
4. Allow the unit to air-dry about one hour before reassembling.
5. The shaker is ready to be returned to service.

Section 5 Specifications

Shaking

Range25-525 RPM
Accuracy1 RPM
MotionOne inch/orbital
IndicatorLCD in 1 RPM increments

Timer

Periods Programmable from 5 minutes to 200 hours or continuous operation
IndicatorLCD in 5 minute increments
Run Time Display counts down for a timed run or counts up when in a “hold” function

Alarms

TimeRun Termination
RPMTracking high/low RPM
Power FailMessage displayed on LCD screen

Safety

RPMIndependent platform motion
-----	----------------------------------

LCD Display

Run Time, RPM, Alarm Conditions, and Power Failure indicated by messages

Drive

Triple-counterbalanced, quiet, belt drive. Accommodates unbalanced platform loads or uneven flask placement

Drive Motor

1/3 HP brushless DC, permanently-lubricated ball bearing

Automatic Restart

Microprocessor retains all programming in non-volatile memory. In the event of a power outage, the shaker restarts automatically.

Dimensions

Exterior . . . 30.5" W x 7.8" H x 25.5" F-B (77.5cm x 19.8cm x 64.8cm)

Electrical

SHKE416/SHKE430 . . .115VAC, 50/60Hz, 1 PH, 1.25 FLA

SHKE416-1CE/SHKE430-1CE . . .230VAC, 50/60Hz, 1 PH, 0.65 FLA

Data OutputRS-232 standard

Remote AlarmTime, RPM and Power Alarms Contacts

Certification

ULUL61010 A-1

Declaration of Conformity available on request

Capacity

With 29.5" x 18.0" Platform Maximum (91) 25ml up to (4) 6L or (6) 2800 ml Fernbach

With 36.0" x 24.0" Platform* Maximum (75) 125ml up to (8) 6L or (12) 2800 ml Fernbach

**Maximum RPM when the 36" x 24" platform is installed is 400 RPM.*

Weight

Net138 lbs. (62.7 kg)

Shipping176 lbs. (79.9 kg)

Ambient Operating Conditions

Temperature4°C (39°F) to 40°C (104°F)

Humidity20% to 90%, non-condensing

Sound Level - Not to exceed 85 dB

Intended Use

Orbital shakers are designed to provide increased aeration in a stable temperature environment.

Unintended Use

- 1) Not intended for use in Class I or II applications as defined in 21 CFR
- 2) Not intended for mixtures of flammable materials

Safety Specifications

Indoor use only

Altitude - 2,000 meters

Temperature - 4°C to 40°C

Humidity - 20% to 90%, non-condensing

Mains Supply Fluctuations - $\pm 10\%$

Installation Category II¹

Pollution Degree 2²

Class of Equipment I

¹ Installation category (overvoltage category) defines the level of transient overvoltage which the instrument is designed to withstand safely. It depends on the nature of the electricity supply and its overvoltage protection means. For example, in CAT II which is the category used for instruments in installations supplied from a supply comparable to public mains such as hospital and research laboratories and most industrial laboratories, the expected transient overvoltage is 1500V for a 230V supply and 1500V for a 120V supply.

² Pollution Degree describes the amount of conductive pollution present in the operating environment. Pollution degree 2 assumes that normally only non-conductive pollution such as dust occurs with the exception of occasional conductivity caused by condensation.

Section 6 Parts

Part No.	Description
156089	Motor, Brushless 24V
191535	Motor Drive Board
190816	LCD Display Panel
192058	Shaker Micro Board
230141	Fuse, 800MA, T.D. 5 x 20 mm
230142	Fuse, 150MA, T.D. 5 x 20 mm
230174	Switch/Circuit Breaker 1.5 Amp
270123	RFI Power Inlet/Filter
360214	Switch, Voltage Select
420064	Transformer, 130VA
420085	Transformer, 25VA
800040	V-Belt, 1/2" x 45"
435051	Screwdriver, Phillips 8-3/4"
443020	Wrench, Hex with T-handle
194046	Spare Part Screw Bag (for platform and clips)
238060	Universal Platform

POWER CONNECTION
 115V, 1PHASE, 50/60HZ, 1A
 OR 230V, 1 PHASE, 50/60 HZ, .5A

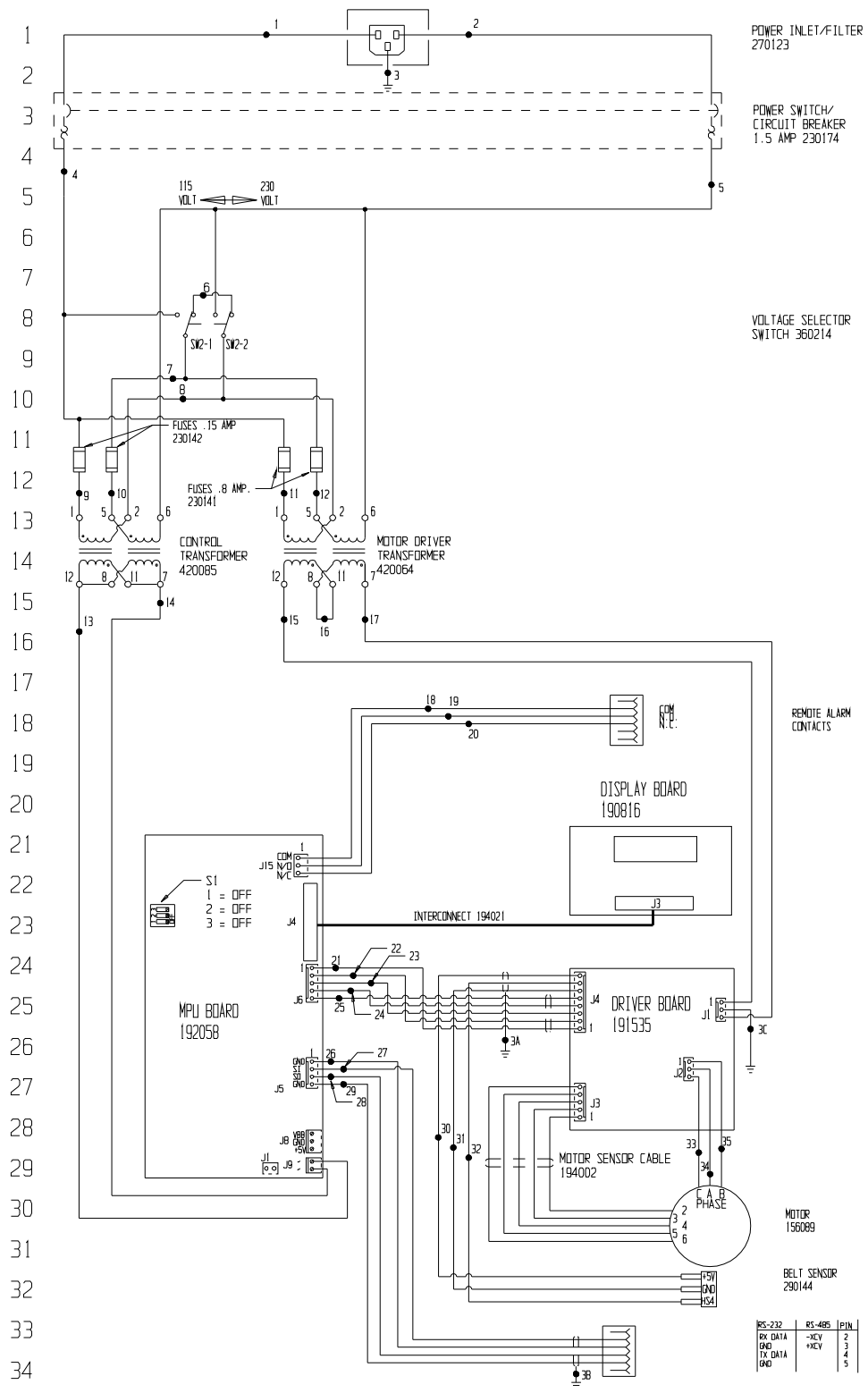

Electrical Schematic
 Model
 416/430
 Tabletop Shaker

416-70-0-D REV. 1
 Page 1 of 2

39
40
41
42
43
44
45
46
47
48
49
50
51
52
53
54
55
56
57
58
59
60
61
62
63
64
65
66
67
68
69
70
71
72
73
74

WIRE REFERENCE CHART

WIRE #	GUAGE	COLOR	WIRE #	GUAGE	COLOR
1	20	BROWN	18	24	GREEN
2	20	BLUE	19	24	RED
3	16	GRN/YEL	20	24	BLACK
4	20	BLACK	21	24	RED
5	20	WHITE	22	24	BLACK
6	20	RED	23	24	GREEN
7	20	BLUE	24	24	BROWN
8	20	PURPLE	25	24	WHITE
9	20	RED	26	24	RED
10	20	ORANGE	27	24	BLACK
11	20	YELLOW	28	24	GREEN
12	20	BROWN	29	24	WHITE
13	20	BROWN	30	24	RED
14	20	BLUE	31	24	BLACK
15	20	RED	32	24	GREEN
16	20	ORANGE	33	18	RED
17	20	RED	34	18	WHITE
			35	18	BLACK

1	DS-751	02-24-14	GLS	GLS	CCS	MICRO BOARD UP-DATE
0	DS-279	02-11-04	BOB	pdk	LON	RELEASED FOR PRODUCTION
REV	ECN NO.	DATE	BY	CAD	APPO	DESCRIPTION OF REVISION

Electrical Schematic
Model
416/430
Tabletop Shaker



ATTENTION
OBSERVE PRECAUTIONS
ELECTROSTATIC
SENSITIVE DEVICES

THIS DOCUMENT CONTAINS PROPRIETARY INFORMATION AND SUCH INFORMATION IS NOT TO BE DISCLOSED TO OTHERS FOR ANY PURPOSE NOR USED FOR MANUFACTURING PURPOSES WITHOUT WRITTEN PERMISSION FROM THERMO FISHER SCIENTIFIC

ThermoFisher
SCIENTIFIC

BOX 649, MARIETTA, OHIO 45750

MODEL/PART NAME: 416/430 TABLE TOP SHAKER					
DWG TITLE: ELECTRICAL SCHEMATIC					
DWN: pdk	CAD: pdk	APPD: LON	DATE: 02-11-04	SCALE: NONE	
MATERIAL: N/A					
PAINT COLOR: N/A					
TOLERANCE UNLESS OTHERWISE SPECIFIED		DRAWING NUMBER		SIZE	
ANGLES:	DECIMAL: .XX=1 .XXX=1	416-70-0		D	

416-70-0-D REV. 1
Page 2 of 2

THERMO FISHER SCIENTIFIC DIGITAL SHAKER WARRANTY USA

The Warranty Period starts two weeks from the date your equipment is shipped from our facility. This allows shipping time so the warranty will go into effect at approximately the same time your equipment is delivered. The warranty protection extends to any subsequent owner during the warranty period.

During the first 24 months, component parts proven to be non-conforming in materials or workmanship will be repaired or replaced at Thermo's expense, labor included. For an additional 3 years, component parts proven to be non-conforming in materials or workmanship will be repaired or replaced at Thermo's expense, labor excluded. In addition, the Orbital Shaker mechanism is warranted for 10 years, parts only, F.O.B. factory. The mechanism is defined as the bearing assemblies. The warranty will be void if the equipment is altered without written authorization from Thermo. Installation and calibration is not covered by this warranty agreement. The Technical Services Department must be contacted for warranty determination and direction prior to performance of any repairs. Expendable items, i.e., glass, filters, light bulbs and lid gaskets are excluded from this warranty. Extended warranties are dependent on the units being maintained regularly as stated in the operation and service manuals.

Replacement or repair of components parts or equipment under this warranty shall not exceed the warranty to either the equipment or to the component part beyond the original warranty period. The Technical Services Department must give prior approval for return of any components or equipment.

THIS WARRANTY IS EXCLUSIVE AND IN LIEU OF ALL OTHER WARRANTIES, WHETHER WRITTEN, ORAL, OR IMPLIED. NO WARRANTIES OF MERCHANTABILITY OR FITNESS FOR A PARTICULAR PURPOSE SHALL APPLY. Thermo shall not be liable for any indirect or consequential damages including, without limitation, damages relating to lost profits or loss of products.

Your local Thermo Sales Office is ready to help with comprehensive site preparation information before your equipment arrives. Printed instruction manuals carefully detail equipment installation, operation, and preventive maintenance.

If equipment service is required, please call your Technical Services Department at 1-800-438-4851 (USA and Canada) or 1-740-373-4763. We're ready to answer any questions on equipment warranty, operation, maintenance, service and special applications. Outside the USA, contact your local distributor for warranty information.



Rev. 2 6/2015

THERMO FISHER SCIENTIFIC INTERNATIONAL DIGITAL SHAKER WARRANTY

The Warranty Period starts two months from the date your equipment is shipped from our facility. This allows shipping time so the warranty will go into effect at approximately the same time your equipment is delivered. The warranty protection extends to any subsequent owner during the warranty period.

During the first 24 months, component parts proven to be non-conforming in materials or workmanship will be repaired or replaced at Thermo's expense, including labor. For an additional 3 years, component parts proven to be non-conforming in materials or workmanship will be repaired or replaced at Thermo's expense, excluding labor. In addition, the Orbital Shaker drive mechanism is warranted for 10 years, parts only, F.O.B. factory. The mechanism is defined as the bearing assemblies. The warranty will be void if the equipment is altered without the written authorization from Thermo. Installation and calibration is not covered by this warranty agreement. The local Thermo Fisher Scientific office must be contacted for warranty determination and direction prior to performance of any repairs. Expendable items, i.e., glass, filters, light bulbs and lid gaskets are excluded from this warranty. Extended warranties are dependent on the units being maintained regularly as stated in the operation and service manuals.

Replacement or repair of component parts or equipment under this warranty shall not exceed the warranty to either the equipment or to the component part beyond the original warranty period. The local Thermo Fisher Scientific office must give prior approval for return of any components or equipment.

THIS WARRANTY IS EXCLUSIVE AND IN LIEU OF ALL OTHER WARRANTIES, WHETHER WRITTEN, ORAL, OR IMPLIED. NO WARRANTIES OF MERCHANTABILITY OR FITNESS FOR A PARTICULAR PURPOSE SHALL APPLY. Thermo shall not be liable for any indirect or consequential damages including, without limitation, damages relating to lost profits or loss of products.

Thermo International Sales Office is ready to help with comprehensive site preparation information before your equipment arrives. Printed instruction manuals carefully detail equipment installation, operation, and preventative maintenance.

If equipment service is required, please call your local Thermo Fisher Scientific office. We're ready to answer your questions on equipment warranty, operation, maintenance, service and special applications.



Rev. 2 6/2015

thermoscientific.com

© 2014 Thermo Fisher Scientific Inc. All rights reserved. All trademarks are the property of Thermo Fisher Scientific and its subsidiaries. Specifications, terms and pricing are subject to change. Not all products are available in all countries. Please consult your local sales representative for details.

Thermo Fisher Scientific
401 Millcreek Road
Marietta, Ohio 45750
United States

Thermo
S C I E N T I F I C
A Thermo Fisher Scientific Brand