

Thermo Scientific BIOLiner™

Instruction Manual

50119954-e • 07 / 2020

WEEE Conformity

This product is subject to the regulations of the EU Waste Electrical & Electronic Equipment (WEEE) Directive 2012/19/EU. It is marked by the following symbol:

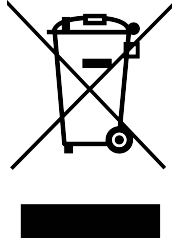

Centre of Emergency Preparedness and Response
Health Protection Agency
Porton Down
Salisbury
Wiltshire SP4 0JG
United Kingdom



Certificate of Containment Testing

Containment testing of Thermo Scientific swing out bucket rotor 75003667 and bucket 75003668

Report No. 59-08 A

Report prepared for: Thermo Fisher
Issue Date: 15th January 2009

Test Summary

A Thermo Scientific centrifuge bucket 75003668 with aerosol tight lid (Max speed 3,500 rpm) was supplied by Thermo Fisher and containment tested at 3,500 rpm using the method described in Annex AA of EN 61010-2-020. The rotor was shown to contain a spill when tested in triplicate.

Report Written By

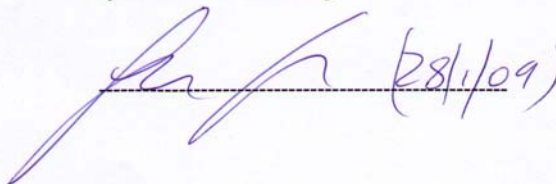

Report Authorised By

_____ (28/1/09)

Centre of Emergency Preparedness and Response
Health Protection Agency
Porton Down
Salisbury
Wiltshire SP4 0JG
United Kingdom



Certificate of Containment Testing

Containment testing of Thermo Scientific swing out bucket rotor 75003667 and bucket 75003670

Report No. 59-08 B

Report prepared for: Thermo Fisher
Issue Date: 15th January 2009

Test Summary

A Thermo Scientific 75003670 centrifuge bucket with aerosol tight lid (Max speed 3,500 rpm) was supplied by Thermo Fisher and containment tested at 3,500 rpm using the method described in Annex AA of EN 61010-2-020. The rotor was shown to contain a spill when tested in triplicate.

Report Written By

A handwritten signature in purple ink, appearing to be "MCP", written over a horizontal dashed line.

Report Authorised By

A handwritten signature in purple ink, appearing to be "A H", written over a horizontal dashed line. To the right of the signature, the date "(28/1/09)" is written in purple ink.

Table of Contents

	Foreword	iii
	Scope of Supply	iii
	Precautions	iii
Chapter 1	Rotor Specifications	1-1
	Technical Data	1-2
Chapter 2	Accessories	2-1
Chapter 3	AutoLock™	3-1
	Rotor Installation	3-2
	Removing the Rotor	3-3
	Aerosol-tight Rotors	3-3
Chapter 4	Rotor Loading	4-1
	Before a Run	4-2
	Proper Loading	4-2
	Improper Loading	4-3
	Maximum Loading	4-3
	Cycle Counter	4-3
Chapter 5	Aerosol-tight Applications	5-1
	Basic Principles	5-2
	Fill Level	5-2
	Checking the aerosol Tightness	5-2
Chapter 6	Maintenance and Care	6-1
	Cleaning Intervals	6-2
	Cleaning	6-2
	Disinfection	6-3
	Decontamination	6-4
	Autoclaving	6-5
	Service of Thermo Fisher Scientific	6-5
	RCF-Values	A-1
	RCF-Values BIOLiner bucket	A-1
	RCF-Values Microplate Carrier	A-2
	Chemical Compatibility Chart	B-1

Foreword

Before starting to use the rotor, read through this instruction manual carefully and follow the instructions.

The information contained in this instruction manual is the property of Thermo Fisher Scientific; it is forbidden to copy or pass on this information without explicit approval.

Failure to follow the instructions and safety information in this instruction manual will result in the expiration of the seller's warranty.

Scope of Supply

Article Number		Quantity	Check
75003602	BIOLiner™	1	<input type="checkbox"/>
76003500	Rubber seal grease	1	<input type="checkbox"/>
70009824	Anti-corrosion oil	1	<input type="checkbox"/>
75003786	Bolt grease	1	<input type="checkbox"/>
50119954	Instruction Manual	1	<input type="checkbox"/>

If any parts are missing, please contact the nearest Thermo Fisher Scientific representative.

Precautions

In order to ensure safe operation of the BIOLiner™, the following general safety regulations must be followed:

- Do not use rotors which show any signs of corrosion and / or cracks. Do not touch the electronic components of the rotor and do not make any changes to the electronic or mechanical components.
- Use only with rotors which have been loaded properly.
- Never overload the rotor.

Foreword

- Use only accessories which have been approved by Thermo Fisher Scientific. Exceptions to this rule are commercially available glass or plastic centrifuge tubes, provided they have been approved for the speed or the RCF value of the rotor.
- Please observe the safety instructions.

Please pay particular attention to the following aspects:

- Rotor installation: Check that the rotor is locked properly into place before operating the centrifuge.
- Always balance the samples.

Maximum sample density at maximum speed: $1.2 \frac{g}{cm^3}$



This symbol refers to general hazards.

ATTENTION means that material damage could occur.

WARNING means that injuries or material damage or contamination could occur.



This symbol refers to biological hazards.

Observe the information contained in the instruction manual to keep yourself and your environment safe.

Rotor Specifications

Contents

- “Technical Data” on page 1-2

Technical Data

Table 1-1. 230 V, 50 / 60 Hz, Rectangular buckets 75003668

Centrifuge	Multifuge X3	Multifuge X3 F	Megafuge 40
Catalog #	75004500	75004530	75004503
Weight empty [kg]	7.3	7.3	7.3
Max. cycle number	55000	55000	55000
Maximum permissible load [g]	4 x 750	4 x 750	4 x 750
Maximum speed n_{\max} [rpm]	3500	3500	3500
Maximum RCF value at n_{\max}	2739	2739	2739
Max. / min. radius [cm]	20 / 10.5	20 / 10.5	20 / 10.5
Pitch angle [°]	90	90	90
Accel. / braking time [s]	55 / 55	55 / 55	55 / 55
Sample heating at n_{\max} [°C] referred to ambient temperature of 23-25 °C, running time 120 minutes	8	8	8
Aerosol-tight*	yes	yes	yes
Permissible temperature range autoclavable (cycle number) °C	121	121	121

* Tested by HPA, Porton-down, UK

Centrifuge	Multifuge X3R	Multifuge X3 FR	Megafuge 40R
Catalog #	75004515	75004536	75004518
Weight empty [kg]	7.3	7.3	7.3
Max. cycle number	55000	55000	55000
Maximum permissible load [g]	4 x 750	4 x 750	4 x 750
Maximum speed n_{\max} [rpm]	3500	3500	3500
Maximum RCF value at n_{\max}	2739	2739	2739
Max. / min. radius [cm]	20 / 10.5	20 / 10.5	20 / 10.5
Pitch angle [°]	90	90	90
Accel. / braking time [s]	55 / 55	55 / 55	55 / 55
Minimum temperature at n_{\max} [°C] relating to ambient temperature 23-25 °C	<0	<0	<0
Speed at 4 °C	3500	3500	3500
Aerosol-tight*	yes	yes	yes
Permissible temperature range autoclavable (cycle number) °C	121	121	121

* Tested by HPA, Porton-down, UK

Table 1-2. 230 V, 50 / 60 Hz, Microplate carriers 75003670

Centrifuge	Multifuge X3	Multifuge X3 F	Megafuge 40
Catalog #	75004500	75004531	75004503
Weight empty [kg]	7.3	7.3	7.3
Max. cycle number	90000	90000	90000
Maximum permissible load [g]	4 x 750	4 x 750	4 x 750
Maximum speed n_{max} [rpm]	3500	3500	3500
Maximum RCF value at n_{max}	2451	2451	2451
Max. / min. radius [cm]	17.9 / 10.5	17.9 / 10.5	17.9 / 10.5
Pitch angle [°]	90	90	90
Accel. / braking time [s]	40 / 50	40 / 50	40 / 50
Sample heating at n_{max} [°C] referred to ambient temperature of 23-25 °C, running time 120 minutes	8	8	8
Aerosol-tight*	yes	yes	yes
Permissible temperature range autoclavable (cycle number) °C	121	121	121

* Tested by HPA, Porton-down, UK

Centrifuge	Multifuge X3R	Multifuge X3 FR	Megafuge 40R
Catalog #	75004515	75004536	75004518
Weight empty [kg]	7.3	7.3	7.3
Max. cycle number	90000	90000	90000
Maximum permissible load [g]	4 x 750	4 x 750	4 x 750
Maximum speed n_{max} [rpm]	3500	3500	3500
Maximum RCF value at n_{max}	2451	2451	2451
Max. / min. radius [cm]	17.9 / 10.5	17.9 / 10.5	17.9 / 10.5
Pitch angle [°]	90	90	90
Accel. / braking time [s]	40 / 50	40 / 50	40 / 50
Minimum temperature at n_{max} [°C] relating to ambient temperature 23-25 °C	<0	<0	<0
Speed at 4 °C	3500	3500	3500
Aerosol-tight*	yes	yes	yes
Permissible temperature range autoclavable (cycle number) °C	121	121	121

* Tested by HPA, Porton-down, UK

Table 1-3. 120 V, 60 Hz, Rectangular buckets 75003668

Centrifuge	Multifuge X3	Multifuge X3 F	Megafuge 40
Catalog #	75004501	75004531	75004504
Weight empty [kg]	7.3	7.3	7.3
Max. cycle number	55000	55000	55000
Maximum permissible load [g]	4 x 750	4 x 750	4 x 750
Maximum speed n_{max} [rpm]	3500	3500	3500
Maximum RCF value at n_{max}	2739	2739	2739
Max. / min. radius [cm]	20 / 10.5	20 / 10.5	20 / 10.5
Pitch angle [°]	90	90	90
Accel. / braking time [s]	75 / 60	75 / 60	75 / 60
Sample heating at n_{max} [°C] referred to ambient temperature of 23-25 °C, running time 120 minutes	8	8	8
Aerosol-tight*	yes	yes	yes
Permissible temperature range autoclavable (cycle number) °C	121	121	121

* Tested by HPA, Porton-down, UK

Centrifuge	Multifuge X3R	Multifuge X3 FR	Megafuge 40R
Catalog #	75004516	75004537	75004519
Weight empty [kg]	7.3	7.3	7.3
Max. cycle number	55000	55000	55000
Maximum permissible load [g]	4 x 750	4 x 750	4 x 750
Maximum speed n_{max} [rpm]	3500	3500	3500
Maximum RCF value at n_{max}	2739	2739	2739
Max. / min. radius [cm]	20 / 10.5	20 / 10.5	20 / 10.5
Pitch angle [°]	90	90	90
Accel. / braking time [s]	70 / 60	70 / 60	70 / 60
Minimum temperature at n_{max} [°C] relating to ambient temperature 23-25 °C	2	2	2
Speed at 4 °C	3500	3500	3500
Aerosol-tight*	yes	yes	yes
Permissible temperature range autoclavable (cycle number) °C	121	121	121

* Tested by HPA, Porton-down, UK

Table 1-4. 120 V, 60 Hz, Microplate carriers 75003670

Centrifuge	Multifuge X3	Multifuge X3 F	Megafuge 40
Catalog #	75004501	75004531	75004504
Weight empty [kg]	7.3	7.3	7.3
Max. cycle number	90000	90000	90000
Maximum permissible load [g]	4 x 750	4 x 750	4 x 750
Maximum speed n_{max} [rpm]	3500	3500	3500
Maximum RCF value at n_{max}	2451	2451	2451
Max. / min. radius [cm]	17.9 / 10.5	17.9 / 10.5	17.9 / 10.5
Pitch angle [°]	90	90	90
Accel. / braking time [s]	60 / 50	60 / 50	60 / 50
Sample heating at n_{max} [°C] referred to ambient temperature of 23-25 °C, running time 120 minutes	8	8	8
Aerosol-tight*	yes	yes	yes
Permissible temperature range autoclavable (cycle number) °C	121	121	121

*Tested by HPA, Porton-down, UK

Centrifuge	Multifuge X3R	Multifuge X3 FR	Megafuge 40R
Catalog #	75004516	75004537	75004519
Weight empty [kg]	7.3	7.3	7.3
Max. cycle number	90000	90000	90000
Maximum permissible load [g]	4 x 750	4 x 750	4 x 750
Maximum speed n_{max} [rpm]	3500	3500	3500
Maximum RCF value at n_{max}	2451	2451	2451
Max. / min. radius [cm]	17.9 / 10.5	17.9 / 10.5	17.9 / 10.5
Pitch angle [°]	90	90	90
Accel. / braking time [s]	50 / 50	50 / 50	50 / 50
Minimum temperature at n_{max} [°C] relating to ambient temperature 23-25 °C	2	2	2
Speed at 4 °C	3500	3500	3500
Aerosol-tight*	yes	yes	yes
Permissible temperature range autoclavable (cycle number) °C	121	121	121

*Tested by HPA, Porton-down, UK

Table 1-5. 230 V, 50 / 60 Hz, Rectangular buckets 75003668

Centrifuge	Sorvall Legend XT	Sorvall Legend XF	Sorvall ST 40
Catalog #	75004505	75004532	75004509
Weight empty [kg]	7.3	7.3	7.3
Max. cycle number	55000	55000	55000
Maximum permissible load [g]	4 x 750	4 x 750	4 x 750
Maximum speed n_{max} [rpm]	3500	3500	3500
Maximum RCF value at n_{max}	2739	2739	2739
Max. / min. radius [cm]	20 / 10.5	20 / 10.5	20 / 10.5
Pitch angle [°]	90	90	90
Accel. / braking time [s]	55 / 55	55 / 55	55 / 55
Sample heating at n_{max} [°C] referred to ambient temperature of 23-25 °C, running time 120 minutes	8	8	8
Aerosol-tight*	yes	yes	yes
Permissible temperature range autoclavable (cycle number) °C	121	121	121

*Tested by HPA, Porton-down, UK

Centrifuge	Sorvall Legend XTR	Sorvall Legend XFR	Sorvall ST 40R
Catalog #	75004520	75004538	75004524
Weight empty [kg]	7.3	7.3	7.3
Max. cycle number	55000	55000	55000
Maximum permissible load [g]	4 x 750	4 x 750	4 x 750
Maximum speed n_{max} [rpm]	3500	3500	3500
Maximum RCF value at n_{max}	2739	2739	2739
Max. / min. radius [cm]	20 / 10.5	20 / 10.5	20 / 10.5
Pitch angle [°]	90	90	90
Accel. / braking time [s]	50 / 55	50 / 55	50 / 55
Minimum temperature at n_{max} [°C] relating to ambient temperature 23-25 °C	<0	<0	<0
Speed at 4 °C	3500	3500	3500
Aerosol-tight*	yes	yes	yes
Permissible temperature range autoclavable (cycle number) °C	121	121	121

*Tested by HPA, Porton-down, UK

Table 1-6. 230 V, 50 / 60 Hz, Microplate carriers 75003670

Centrifuge	Sorvall Legend XT	Sorvall Legend XF	Sorvall ST 40
Catalog #	75004505	75004532	75004509
Weight empty [kg]	7.3	7.3	7.3
Max. cycle number	90000	90000	90000
Maximum permissible load [g]	4 x 750	4 x 750	4 x 750
Maximum speed n_{max} [rpm]	3500	3500	3500
Maximum RCF value at n_{max}	2451	2451	2451
Max. / min. radius [cm]	17.9 / 10.5	17.9 / 10.5	17.9 / 10.5
Pitch angle [°]	90	90	90
Accel. / braking time [s]	40 / 50	40 / 50	40 / 50
Sample heating at n_{max} [°C] referred to ambient temperature of 23-25 °C, running time 120 minutes	8	8	8
Aerosol-tight*	yes	yes	yes
Permissible temperature range autoclavable (cycle number) °C	121	121	121

* Tested by HPA, Porton-down, UK

Centrifuge	Sorvall Legend XTR	Sorvall Legend XFR	Sorvall ST 40R
Catalog #	75004520	75004538	75004524
Weight empty [kg]	7.3	7.3	7.3
Max. cycle number	90000	90000	90000
Maximum permissible load [g]	4 x 750	4 x 750	4 x 750
Maximum speed n_{max} [rpm]	3500	3500	3500
Maximum RCF value at n_{max}	2451	2451	2451
Max. / min. radius [cm]	17.9 / 10.5	17.9 / 10.5	17.9 / 10.5
Pitch angle [°]	90	90	90
Accel. / braking time [s]	40 / 50	40 / 50	40 / 50
Minimum temperature at n_{max} [°C] relating to ambient temperature 23-25 °C	<0	<0	<0
Speed at 4 °C	3500	3500	3500
Aerosol-tight*	yes	yes	yes
Permissible temperature range autoclavable (cycle number) °C	121	121	121

* Tested by HPA, Porton-down, UK

Table 1-7. 120 V, 60 Hz, Rectangular buckets 75003668

Centrifuge	Sorvall Legend XT	Sorvall Legend XF	Sorvall ST 40
Catalog #	75004506	75004533	75004510
Weight empty [kg]	7.3	7.3	7.3
Max. cycle number	55000	55000	55000
Maximum permissible load [g]	4 x 750	4 x 750	4 x 750
Maximum speed n_{max} [rpm]	3500	3500	3500
Maximum RCF value at n_{max}	2739	2739	2739
Max. / min. radius [cm]	20 / 10.5	20 / 10.5	20 / 10.5
Pitch angle [°]	90	90	90
Accel. / braking time [s]	75 / 60	75 / 60	75 / 60
Sample heating at n_{max} [°C] referred to ambient temperature of 23-25 °C, running time 120 minutes	8	8	8
Aerosol-tight*	yes	yes	yes
Permissible temperature range autoclavable (cycle number) °C	121	121	121

* Tested by HPA, Porton-down, UK

Centrifuge	Sorvall Legend XTR	Sorvall Legend XFR	Sorvall ST 40R
Catalog #	75004521	75004539	75004525
Weight empty [kg]	7.3	7.3	7.3
Max. cycle number	55000	55000	55000
Maximum permissible load [g]	4 x 750	4 x 750	4 x 750
Maximum speed n_{max} [rpm]	3500	3500	3500
Maximum RCF value at n_{max}	2739	2739	2739
Max. / min. radius [cm]	20 / 10.5	20 / 10.5	20 / 10.5
Pitch angle [°]	90	90	90
Accel. / braking time [s]	70 / 60	70 / 60	70 / 60
Minimum temperature at n_{max} [°C] relating to ambient temperature 23-25 °C	2	2	2
Speed at 4 °C	3500	3500	3500
Aerosol-tight*	yes	yes	yes
Permissible temperature range autoclavable (cycle number) °C	121	121	121

* Tested by HPA, Porton-down, UK

Table 1-8. 120 V, 60 Hz Microplate carriers 75003670

Centrifuge	Sorvall Legend XT	Sorvall Legend XF	Sorvall ST 40
Catalog #	75004506	75004533	75004510
Weight empty [kg]	7.3	7.3	7.3
Max. cycle number	90000	90000	90000
Maximum permissible load [g]	4 x 750	4 x 750	4 x 750
Maximum speed n_{max} [rpm]	3500	3500	3500
Maximum RCF value at n_{max}	2451	2451	2451
Max. / min. radius [cm]	17.9 / 10.5	17.9 / 10.5	17.9 / 10.5
Pitch angle [°]	90	90	90
Accel. / braking time [s]	60 / 50	60 / 50	60 / 50
Sample heating at n_{max} [°C] referred to ambient temperature of 23-25 °C, running time 120 minutes	8	8	8
Aerosol-tight*	yes	yes	yes
Permissible temperature range autoclavable (cycle number) °C	121	121	121

* Tested by HPA, Porton-down, UK

Centrifuge	Sorvall Legend XTR	Sorvall Legend XFR	Sorvall ST 40R
Catalog #	75004521	75004539	75004525
Weight empty [kg]	7.3	7.3	7.3
Max. cycle number	90000	90000	90000
Maximum permissible load [g]	4 x 750	4 x 750	4 x 750
Maximum speed n_{max} [rpm]	3500	3500	3500
Maximum RCF value at n_{max}	2451	2451	2451
Max. / min. radius [cm]	17.9 / 10.5	17.9 / 10.5	17.9 / 10.5
Pitch angle [°]	90	90	90
Accel. / braking time [s]	50 / 50	50 / 50	50 / 50
Minimum temperature at n_{max} [°C] relating to ambient temperature 23-25 °C	2	2	2
Speed at 4 °C	3500	3500	3500
Aerosol-tight*	yes	yes	yes
Permissible temperature range autoclavable (cycle number) °C	121	121	121

* Tested by HPA, Porton-down, UK

Table 1-9. 100 V, 50 / 60 Hz, Rectangular buckets 75003668

Centrifuge	Sorvall Legend XT	Sorvall Legend XF
Catalog #	75004508	75004535
Weight empty [kg]	7.3	7.3
Max. cycle number	55000	55000
Maximum permissible load [g]	4 x 750	4 x 750
Maximum speed n_{max} [rpm]	3500	3500
Maximum RCF value at n_{max}	2739	2739
Max. / min. radius [cm]	20 / 10.5	20 / 10.5
Pitch angle [°]	90	90
Accel. / braking time [s]	75 / 60	75 / 60
Sample heating at n_{max} [° C] referred to ambient temperature of 23-25 °C, running time 120 minutes	8	8
Aerosol-tight*	yes	yes
Permissible temperature range autoclavable (cycle number) °C	121	121

* Tested by HPA, Porton-down, UK

Centrifuge	Sorvall Legend XTR	Sorvall Legend XFR
Catalog #	75004523	75004541
Weight empty [kg]	7.3	7.3
Max. cycle number	55000	55000
Maximum permissible load [g]	4 x 750	4 x 750
Maximum speed n_{max} [rpm]	3500	3500
Maximum RCF value at n_{max}	2739	2739
Max. / min. radius [cm]	20 / 10.5	20 / 10.5
Pitch angle [°]	90	90
Accel. / braking time [s]	70 / 60	70 / 60
Minimum temperature at n_{max} [°C] relating to ambient temperature 23-25 °C	2	2
Speed at 4 °C	3500	3500
Aerosol-tight*	yes	yes
Permissible temperature range autoclavable (cycle number) °C	121	121

* Tested by HPA, Porton-down, UK

Table 1-9. 100 V, 50 / 60 Hz, Microplate carriers 75003670

Centrifuge	Sorvall Legend XT	Sorvall Legend XF	Sorvall ST 40
Catalog #	75004507	75004534	75004511
Weight empty [kg]	7.3	7.3	7.3
Max. cycle number	90000	90000	90000
Maximum permissible load [g]	4 x 500	4 x 500	4 x 500
Maximum speed n_{max} [rpm]	3500	3500	3500
Maximum RCF value at n_{max}	2739	2739	2739
Max. / min. radius [cm]	17.9 / 14.6	17.9 / 14.6	17.9 / 14.6
Pitch angle [°]	90	90	90
Accel. / braking time [s]	60 / 50	60 / 50	60 / 50
Sample heating at n_{max} [° C] referred to ambient temperature of 23-25 °C, running time 60 minutes	8	8	8
Aerosol-tight*	yes	yes	yes
Permissible temperature range autoclavable (cycle number) °C	121	121	121

* Tested by HPA, Porton-down, UK

Centrifuge	Sorvall Legend XTR	Sorvall Legend XFR	Sorvall ST 40R
Catalog #	75004522	75004540	75004526
Weight empty [kg]	7.3	7.3	7.3
Max. cycle number	90000	90000	90000
Maximum permissible load [g]	4 x 500	4 x 500	4 x 500
Maximum speed n_{max} [rpm]	3500	3500	3500
Maximum RCF value at n_{max}	2739	2739	2739
Max. / min. radius [cm]	17.9 / 14.6	17.9 / 14.6	17.9 / 14.6
Pitch angle [°]	90	90	90
Accel. / braking time [s]	50 / 50	50 / 50	50 / 50
Aerosol-tight*	yes	yes	yes
Permissible temperature range autoclavable (cycle number) °C	121	121	121

* Tested by HPA, Porton-down, UK

Table 1-10. 230 V, 50 / 60 Hz, Rectangular buckets 75003668

Centrifuge	Thermo Scientific SL 40	Thermo Scientific SL 40 F
Catalog #	75004512	75004542
Weight empty [kg]	7.3	7.3
Max. cycle number	55000	55000
Maximum permissible load [g]	4 x 750	4 x 750
Maximum speed n_{\max} [rpm]	3500	3500
Maximum RCF value at n_{\max}	2739	2739
Max. / min. radius [cm]	20 / 10.5	20 / 10.5
Pitch angle [°]	90	90
Accel. / braking time [s]	55 / 50	55 / 55
Sample heating at n_{\max} [°C] referred to ambient temperature of 23-25 °C, running time 120 minutes	8	8
Aerosol-tight*	yes	yes
Permissible temperature range autoclavable (cycle number) °C	121	121

*Tested by HPA, Porton-down, UK

Centrifuge	Thermo Scientific SL 40R	Thermo Scientific SL 40 FR
Catalog #	75004527	75004543
Weight empty [kg]	7.3	7.3
Max. cycle number	55000	55000
Maximum permissible load [g]	4 x 750	4 x 750
Maximum speed n_{\max} [rpm]	3500	3500
Maximum RCF value at n_{\max}	2739	2739
Max. / min. radius [cm]	20 / 10.5	20 / 10.5
Pitch angle [°]	90	90
Accel. / braking time [s]	55 / 50	55 / 55
Minimum temperature at n_{\max} [°C] relating to ambient temperature 23-25 °C	<0	<0
Speed at 4 °C	3500	3500
Aerosol-tight*	yes	yes
Permissible temperature range autoclavable (cycle number) °C	121	121

*Tested by HPA, Porton-down, UK

Table 1-11. 230 V, 50 / 60 Hz, Microplate carriers 75003670

Centrifuge	Thermo Scientific SL 40	Thermo Scientific SL 40 F
Catalog #	75004512	75004542
Weight empty [kg]	7.3	7.3
Max. cycle number	90000	90000
Maximum permissible load [g]	4 x 750	4 x 750
Maximum speed n_{max} [rpm]	3500	3500
Maximum RCF value at n_{max}	2451	2451
Max. / min. radius [cm]	17.9 / 10.5	17.9 / 10.5
Pitch angle [°]	90	90
Accel. / braking time [s]	55 / 50	40 / 50
Sample heating at n_{max} [°C] referred to ambient temperature of 23-25 °C, running time 120 minutes	8	8
Aerosol-tight*	yes	yes
Permissible temperature range autoclavable (cycle number) °C	121	121

* Tested by HPA, Porton-down, UK

Centrifuge	Thermo Scientific SL 40R	Thermo Scientific SL 40 FR
Catalog #	75004527	75004543
Weight empty [kg]	7.3	7.3
Max. cycle number	90000	90000
Maximum permissible load [g]	4 x 750	4 x 750
Maximum speed n_{max} [rpm]	3500	3500
Maximum RCF value at n_{max}	2451	2451
Max. / min. radius [cm]	17.9 / 10.5	17.9 / 10.5
Pitch angle [°]	90	90
Accel. / braking time [s]	55 / 50	40 / 50
Minimum temperature at n_{max} [°C] relating to ambient temperature 23-25 °C	<0	<0
Speed at 4 °C	3500	3500
Aerosol-tight*	yes	yes
Permissible temperature range autoclavable (cycle number) °C	121	121

* Tested by HPA, Porton-down, UK

Table 1-12. 120 V, 60 Hz, Rectangular buckets 75003668

Centrifuge	Thermo Scientific SL 40
Catalog #	75004513
Weight empty [kg]	7.3
Max. cycle number	55000
Maximum permissible load [g]	4 x 750
Maximum speed n_{max} [rpm]	3500
Maximum RCF value at n_{max}	2739
Max. / min. radius [cm]	20 / 10.5
Pitch angle [°]	90
Accel. / braking time [s]	55 / 50
Sample heating at n_{max} [° C] referred to ambient temperature of 23-25 °C, running time 120 minutes	8
Aerosol-tight*	yes
Permissible temperature range autoclavable (cycle number) °C	121

*Tested by HPA, Porton-down, UK

Centrifuge	Thermo Scientific SL 40R
Catalog #	75004528
Weight empty [kg]	7.3
Max. cycle number	55000
Maximum permissible load [g]	4 x 750
Maximum speed n_{max} [rpm]	3500
Maximum RCF value at n_{max}	2739
Max. / min. radius [cm]	20 / 10.5
Pitch angle [°]	90
Accel. / braking time [s]	55 / 50
Minimum temperature at n_{max} [°C] relating to ambient temperature 23-25 °C	2
Speed at 4 °C	3500
Aerosol-tight*	yes
Permissible temperature range autoclavable (cycle number) °C	121

*Tested by HPA, Porton-down, UK

Table 1-13. 120 V, 60 Hz, Microplate carriers 75003670

Centrifuge	Thermo Scientific SL 40
Catalog #	75004513
Weight empty [kg]	7.3
Max. cycle number	90000
Maximum permissible load [g]	4 x 750
Maximum speed n_{max} [rpm]	3500
Maximum RCF value at n_{max}	2451
Max. / min. radius [cm]	17.9 / 10.5
Pitch angle [°]	90
Accel. / braking time [s]	55 / 50
Sample heating at n_{max} [° C] referred to ambient temperature of 23-25 °C, running time 120 minutes	8
Aerosol-tight*	yes
Permissible temperature range autoclavable (cycle number) °C	121

* Tested by HPA, Porton-down, UK

Centrifuge	Thermo Scientific SL 40R
Catalog #	75004528
Weight empty [kg]	7.3
Max. cycle number	90000
Maximum permissible load [g]	4 x 750
Maximum speed n_{max} [rpm]	3500
Maximum RCF value at n_{max}	2451
Max. / min. radius [cm]	17.9 / 10.5
Pitch angle [°]	90
Accel. / braking time [s]	55 / 50
Minimum temperature at n_{max} [°C] relating to ambient temperature 23-25 °C	2
Speed at 4 °C	3500
Aerosol-tight*	yes
Permissible temperature range autoclavable (cycle number) °C	121

* Tested by HPA, Porton-down, UK

Accessories

Contents

- “Rotor data” on page 2-2
- “Accessories” on page 2-2
- “Bottle 75003699” on page 2-3

Thermo Scientific General Purpose Rotors

BIOLiner High Capacity Rotor

BIOLiner High Capacity Rotor



Rotor Specifications	
Capacity (ml)	4 x 750
Tube Dimensions (mm)	98 x 124
Angle °	90
Maximum Speed (rpm)	3500
K Factor	13307
Net Weight (kg)	7.3

RCF/Radius	RCF (x g)	Radius (cm)
Maximum	2739	20
Minimum	1436	10.5



BIOLiner Rotor Packages

Cat. No.	Description
75003667	BIOLiner High Capacity Rotor Body
75003668	Set of 4 BIOLiner Buckets without sealing lids
75003669	Set of 4 ClickSeal Lids for BIOLiner Buckets
75003688	Replacement O-rings for BIOLiner Sealing Lids 75003669 (Set of 4)
75003670	Set of 4 Non-Sealed Microplate Carriers for BIOLiner Rotor
75003689	Set of 4 Sealing Lids for Microplate Carriers for BIOLiner Rotor
75003626	Replacement O-rings for BIOLiner Microplate Lids 75003689 (Set of 4)

Tube Ordering Information

Cat. No.	Tube Vol. (ml)	Vol. Fill (ml)	Description	Qty.	Max. Speed (rpm)	Dims Ø x L (mm)	Sealing Assembly Required:			Adapters Required:		Accessories Required:		
							Cat. No.	Qty /Pkg	Description	Cat. No.	Qty /Pkg	No. of Places		
75003699	750	750	PP Bio-Bottle	12	3500	98 x 135	Included	12	PP Sealing	75003692	4	1	-	-
-	500	500	Corning Conical	-	3500	98 x 124	-	-	-	75003692+Corning Cushion#431124	4	1	-	-
-	250	250	Corning Conical	-	3500	62 x 145	-	-	-	75003691	4	1	-	-
3141-0250	250	250	PP Oak Ridge Bottle	4	3500	62 x 130	Included	4	PP Sealing	75003675	4	2	-	-
3140-0250	250	250	PC OakRidge Bottle	4	3500	62 x 130	Included	4	PP Sealing	75003675	4	2	-	-
-	225	225	BD Conical	-	3500	62 x 130	-	-	-	75003675+BD Cushion # 352090	4	2	-	-
376813	200	200	Nunc Conical	4	3500	62 x 130	Included	4	PP Sealing	75003675+ Nunc Cushion #377585	4	2	-	-
-	175	175	BD Conical	-	3500	62 x 130	-	-	-	75003675+BD Cushion # 352090	4	2	-	-
334959	50	50	Nunc Conical	25	3500	30 x 120	Included	25	PP Sealing	75003674	4	10	*Max Capacity may vary by tube brand	
366036	15	15	Nunc Conical	50	3500	17.5 x 121	Included	50	PP Sealing	75003673	4	22	-	-
-	10	-	Blood Collection	-	-	17 x 110	-	-	-	75003672	4	37	-	-
-	7	-	Blood Collection	-	-	14 x 110	-	-	-	75003671	4	49	-	-
-	5	-	Blood Collection Standard	-	-	13 x 75	-	-	-	75003671	4	49	-	-
-	MP	-	Microplates (up to 20 mm)	-	-	Max Height 60 mm	-	-	-	75003670	4	4	-	-
-	MP	-	Deepwell Plates (up to 30 mm)	-	-	Max Height 60 mm	-	-	-	75003670	4	2	-	-

Bottle 75003699

Please observe the following when using bottle 75003699:

The bottle 75003699 has a volume of 750 ml and can be filled up to the second thread rotation from the upper edge.

The bottle should be filled to min. 80 %.

The top is a single piece. Close the filled bottle and tighten the top firmly.

Weigh the bottles opposite in order to avoid an imbalance. Refer to the rotor loading chapter.



CAUTION The bottle 75003699 is a wearing product. Bottle with signs of wear are no longer to be used. Replace the bottles. Damaged bottles can cause damage to the rotor and centrifuge.

AutoLock™

Contents

- “Rotor Installation” on page 3-2
- “Removing the Rotor” on page 3-3

Rotor Installation



CAUTION Unapproved or incorrectly combined accessories can cause serious damage to the centrifuge.

This rotor is equipped with an AutoLock™-system.

This system is used to automatically lock the rotor to the centrifuge spindle. The rotor does not have to be bolted onto the centrifuge spindle.

Proceed as follows:

1. Open the lid of the centrifuge and if necessary, remove any dust, foreign objects or residue from the chamber.
AutoLock™ and O-ring must be clean and undamaged.

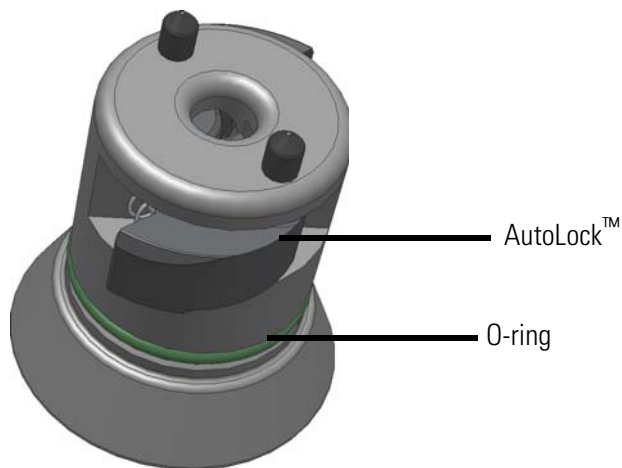

Figure 3-1. AutoLock™

2. Hold the rotor over the centrifuge spindle and let it slide slowly down the centrifuge spindle. The rotor clicks automatically into place.



CAUTION Do not force the rotor onto the centrifuge spindle. If the rotor is very light, then it may be necessary to press it onto the centrifuge spindle with a small amount of pressure.

3. Check if the rotor is properly installed by lifting slightly on the handle. If the rotor can be pulled up, then it must be reclamped to the centrifuge spindle.



WARNING If the rotor cannot be properly locked in place after several attempts, then the AutoLock™ is defective and you are not permitted to operate the rotor. Check for any damage to the rotor, damaged rotors must not be used. Keep the hub area clear of objects.



CAUTION Check that the rotor is properly locked on the centrifuge spindle before each use by pulling its handle.



Be sure to check all seals before starting any aerosol-tight applications.

4. Close the centrifuge door.

Removing the Rotor

To remove the rotor, proceed as follows:

1. Open the centrifuge door.
2. Grab the rotor handle with both hands and press against the green AutoLock™ button. At the same time, pull the rotor directly upwards with both hands and remove it from the centrifuge spindle. Make sure not to jam the rotor while doing this.



Figure 3-2. Handling of AutoLock™

Aerosol-tight Rotors



CAUTION Rotors supplied with a lid for aerosol-tight applications come with a mandril, which belongs to the AutoLock™. Be sure not to place the lid onto this mandril to prevent it from being damaged.

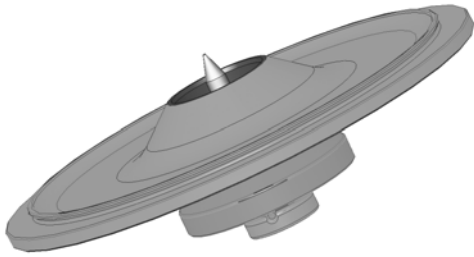

Figure 3-3. AutoLock™-lid for aerosol-tight rotors



WARNING Mind the AutoLock™-mandril inside the lid. Do not touch.

Rotor Loading

Contents

- “Before a Run” on page 4-2
- “Proper Loading” on page 4-2
- “Improper Loading” on page 4-3
- “Maximum Loading” on page 4-3
- “Cycle Counter” on page 4-3

Before a Run

1. Please read and observe the safety instructions contained in these operating instructions and in the instructions for use.
2. Check the rotor and all accessory parts for damages such as cracks, scratches or traces of corrosion.
3. Check the rotor chamber, the motor shaft and the AutoLock™.
4. Check the rotor suitability using the chemical compatibility chart on [page B-1](#).
5. Make sure the tubes or bottles do not touch the bucket caps.
6. Check the rotor bolts and apply grease 75003786 before using for the first time.
7. Check that each bucket or microplate carrier can swing freely by moving it carefully with your hand.
8. Weigh the bucket content (adapter and tube). Be sure not to overload the rotor while doing this.



CAUTION Always use identical bucket types in a rotor. Always be sure to use buckets of the same weight class, which is marked on the buckets themselves.

Proper Loading

To ensure safe operation of the centrifuge, the rotor must be evenly loaded at all times.

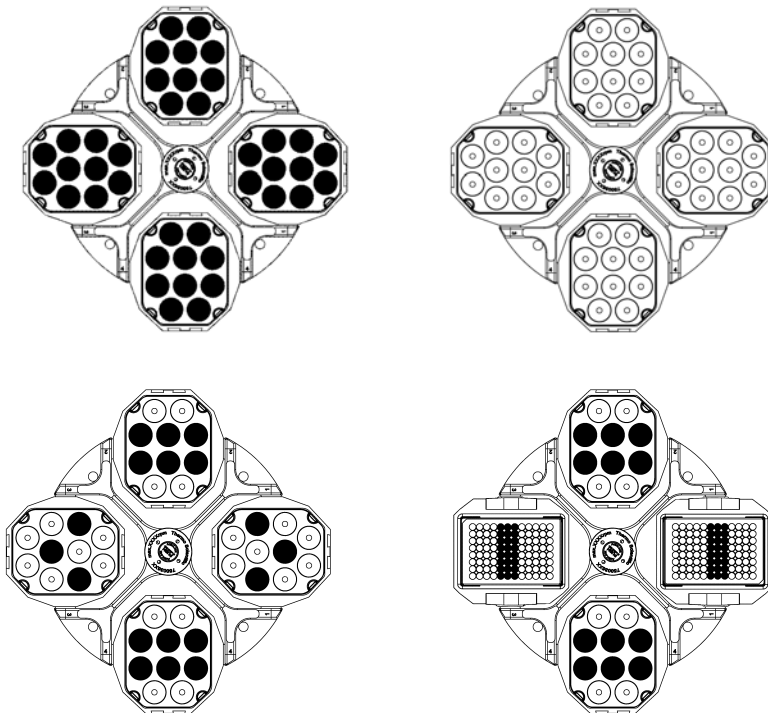

You can use two rectangular buckets or two round buckets or two microplate carriers. Make sure that the opposing receptacles are holding tubes of the same weight.

Improper Loading

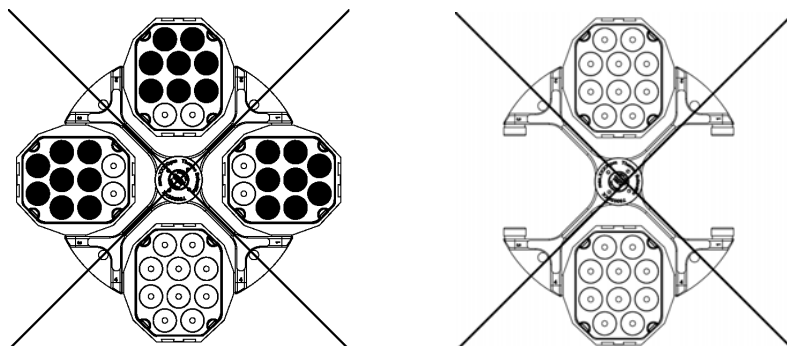

Maximum Loading

The rotor can run at high speeds. The rotor design has sufficient reserve stability even when spinning at top speed.

The safety system of the centrifuge requires that you do not overload the rotor.

There are two options available for centrifuging samples whose weight, including adapter, exceeds the maximum permissible load:

Reduce the fill level.

Recalculate the maximum permissible speed according to the following formula and select the calculated maximum speed for the centrifuge:

$$n_{\text{adm}} = n_{\text{max}} \sqrt{\frac{\text{Maximum permissible load}}{\text{Effective load}}}$$

n_{adm} = admissible speed
 n_{max} = maximum speed

Cycle Counter

The lifetime of rotors and buckets is dependent on the amount of mechanical load. Do not exceed the number of cycles recommended for rotors and buckets.

The maximum number of cycles is given in the rotor table in the rotor specification section.

The maximum number of cycles for buckets is marked on the buckets themselves.



WARNING Replace the rotor when the specified number of cycles is reached. Due to the mechanical load a rotor can break and thus damage the centrifuge. Replace the buckets when the specified number of cycles is reached.

Service life examples

Usage profile	Maximum service life at 50000 cycles
frequent use 20 runs / day 220 days / year	11 years

Aerosol-tight Applications

Contents

- “Basic Principles” on page 5-2
- “Fill Level” on page 5-2
- “Checking the aerosol Tightness” on page 5-2

Basic Principles



CAUTION When centrifuging hazardous samples, do not open aerosol-tight rotors or buckets unless placed in a safety cabinet.

CAUTION Always bear in mind the maximum permitted fill levels.



Be sure to check all seals before starting any aerosol-tight applications.

1. Check that the sample containers are well suited for the desired centrifugation process.

Fill Level

The vessels are only to be filled to a level which ensures that the sample is unable to reach the edge of the vessel during centrifuging.

Keep in mind the advised fill levels

Rated level:	Admissible level
2.0 ml	1.5 ml
1.5 ml	1.0 ml
other	2/3 of the rated level

Checking the aerosol Tightness

The aerosol tightness testing of the rotors and buckets took place according to the microbiological test process in accordance with the EN 61010-2-020 Appendix AA.

Whether or not a rotor is aerosol-tight depends primarily on proper handling!

Check as needed to make sure your rotor is aerosol-tight!

The careful inspection of the seals and seal surfaces for signs of wear and damage such as cracks, scratches and embrittlement is extremely important!

Aerosol-tight applications are not possible if the vessel tops are open.

Aerosol-tightness requires the correct operation when filling the sample vessels and closing the rotor lid.

Quick test

As a quick test, it is possible to test the aerosol-tight beaker and fixed-angle rotors using the following process:

1. Lubricate all seals lightly.
Always use the special grease 76003500 when lubricating the seals 76003500!
2. Fill the bucket or the rotor with approx. 10 ml of carbonated mineral water.
3. Close the bucket or the rotor as explained in the handling instructions.
4. Shake the bucket or the rotor vigorously using your hands.
This releases the carbonic acid gas, which is bound in the water, resulting in excess pressure. Do not apply pressure to the lid when doing so!
Leaks can be detected by escaping water or the sound of escaping gas.
Replace the seals if you detect any leaks. Then repeat the test.
5. Dry the rotor, rotor cover and the cover seal.



CAUTION Prior to each use, the seals in the rotors are to be inspected in order to assure that they are correctly seated and are not worn or damaged. Damaged seals are to be replaced immediately. Replacement seals are supplied with the rotors and can also be re-ordered as a spare parts set 75003626. When loading the rotor, ensure that the rotor lid closes securely. Damaged or clouded rotor covers are to be replaced immediately.

Aerosol-tight Closure with ClickSeal

1. If necessary, grease the lid joint before closing the lid. Use grease 76003500 for this.
2. Raise the latch.
The cap can now be easily placed on the bucket.



Figure 5-4. Bucket with open lid

3. Lower the latch to close the bucket aerosol-tight; be sure the latch clicks into place.

5 Aerosol-tight Applications

Checking the aerosol Tightness



Figure 5-5. Bucket with closed lid



CAUTION If the latch is not flipped down, the caps could be damaged during centrifuging.

If the latch has not clicked into place, the bucket is not aerosol-tight.

Never raise the bucket at its latch.

Maintenance and Care

Contents

- “Cleaning Intervals” on page 6-2
- “Cleaning” on page 6-2
- “Disinfection” on page 6-3
- “Decontamination” on page 6-4
- “Autoclaving” on page 6-5
- “Service of Thermo Fisher Scientific” on page 6-5

Cleaning Intervals

For the sake of personal, environmental and material protection, it is your duty to clean and if necessary, disinfect the centrifuge on a regular basis.

Maintenance	Recommended interval
Clean rotor chamber	Daily or when polluted
Clean rotor	Daily or when polluted
Accessories	Daily or when polluted
Cabinet	Once per month
Ventilation holes	Every six months



CAUTION Refrain from using any other cleaning or decontamination procedure than those recommended here, if you are not entirely sure that the intended procedure is safe for the equipment.
Use only approved cleansers.
If in doubt, contact Thermo Fisher Scientific.

Cleaning

When cleaning centrifuge:

- Use warm water with a neutral solvent.
- Never use caustic cleaning agents such as soap suds, phosphoric acid, bleaching solutions or scrubbing powder.
- Rinse the cavities out thoroughly.
- Use a soft brush without metal bristles to remove stubborn residue.
- Afterwards rinse with distilled water.
- Place the rotors on a plastic grate with their cavities pointing down.
- If drying boxes are used, the temperature must never exceed 50 °C, since higher temperatures could damage the material and shorten the lifetime of the parts.
- Use only disinfectants with a pH of 6-8.
- Dry aluminium parts off with a soft cloth.
- After cleaning, treat the entire surface of aluminium parts with corrosion protection oil (70009824). Also treat the cavities with oil.
- Store the aluminium parts at room temperature or in a cold-storage room with the cavities pointing down.



CAUTION Before using any cleaning or decontamination methods except those recommended by the manufacturer, users should check with the manufacturer that the proposed method will not damage the equipment.

Clean centrifuge and accessories as follows:

1. Open the centrifuge.
2. Turn off the centrifuge.
3. Pull out the power supply plug.
4. Grasp the rotor with both hands and lift it vertically off the centrifuge spindle.
5. Remove the centrifuge tubes and adapters.
6. Use a neutral cleaning agent with a pH value between 6 and 8 for cleaning.
7. Dry all of the rotors and accessories after cleaning with a cloth or in a warm air cabinet at a maximum temperature of 50 °C.
8. Clean the housing of the centrifuge as needed.
 - After cleaning, treat the entire surface of aluminium parts with corrosion protection oil (70009824). Also treat the cavities with oil.
 - Treat the bolt of the swing out rotor with bolt grease (75003786).



CAUTION When cleaning, do not allow liquids, especially organic solvents, to get on the drive shaft, the bearings, the AutoLock™ or the locks. Organic solvents break down the grease in the motor bearing. The drive shaft could freeze up.

After some applications, there might be ice in the rotor chamber. Let the ice melt and drain it off. Clean the rotor chamber as described above.

Disinfection

Disinfect the centrifuge immediately whenever infectious material has spilled during centrifugation.



WARNING Infectious material can get into the centrifuge when a tube breaks or as a result of spills. Keep in mind the risk of infection when touching the rotor and take all necessary precautions. In case of contamination, make sure that others are not put at risk. Decontaminate the affected parts immediately. Take other precautions if need be.

Use a sprayer whenever possible so that all surfaces are covered evenly.

The rotor chamber and the rotor should be treated preferably with a neutral disinfectant. A disinfectant spray would be most suitable for this purpose so that the rotor and accessory surfaces are covered evenly.



CAUTION Before using any cleaning or decontamination methods except those recommended by the manufacturer, users should check with the manufacturer that the proposed method will not damage the equipment. Observe the safety precautions and handling instructions for the cleaning agents used.

Contact the Service Department of Thermo Fisher Scientific for questions regarding the use of other disinfectants.

Disinfect the rotor and accessories as follows:

1. Open the centrifuge.
2. Turn off the centrifuge.
3. Pull out the power supply plug.
4. Grasp the rotor with both hands and lift it vertically off the centrifuge spindle.
5. Remove the centrifuge tubes and adapters and dispose of them or disinfect them.
6. Treat the rotor and accessories according to the instructions for the disinfectant (spray or soak in solution). Adhere strictly to the given application times.
7. Be sure the disinfectant can drain off the rotor.
8. Rinse the rotor and rotor lid thoroughly with water and then rub down.
9. Dispose of the disinfectant according to the applicable guidelines.
10. Dry all of the rotors and accessories after cleaning with a cloth or in a warm air cabinet at a maximum temperature of 50 °C.
 - After cleaning, treat the entire surface of aluminium parts with corrosion protection oil (70009824). Also treat the cavities with oil.
 - Treat the bolt of the swing out rotor with bolt grease (75003786).

Decontamination

Decontaminate the centrifuge immediately, whenever radioactive material has spilled during centrifugation.



WARNING Radioactive material can get into the centrifuge when a tube breaks or as a result of spills. Keep in mind the risk of infection when touching the rotor and take all necessary precautions.

In case of contamination, make sure that others are not put at risk.

Decontaminate the affected parts immediately.

Take other precautions if need be.



CAUTION Before using any cleaning or decontamination methods except those recommended by the manufacturer, users should check with the manufacturer that the proposed method will not damage the equipment.

For general radioactive decontamination use a solution of equal parts of 70 % ethanol, 10 % SDS and water.

Disinfect the rotor and accessories as follows:

1. Open the centrifuge.
2. Turn off the centrifuge.
3. Pull out the power supply plug.

4. Grasp the rotor with both hands and lift it vertically off the centrifuge spindle.
5. Remove the centrifuge tubes and adapters and dispose of them or disinfect them.
6. Rinse the rotor first with ethanol and then with de-ionized water.
 - Adhere strictly to the given application times.
7. Be sure the decontamination solution can drain off the rotor.
8. Rinse the rotor and accessories thoroughly with water.
9. Dispose of the decontamination solution according to the applicable guidelines.
10. Dry all of the rotors and accessories after cleaning with a cloth or in a warm air cabinet at a maximum temperature of 50 °C.
 - After cleaning, treat the entire surface of aluminium parts with corrosion protection oil (70009824). Also treat the cavities with oil.
 - Treat the bolt of the swing out rotor with bolt grease (75003786).

Autoclaving

1. Before autoclaving clean rotor and accessories and described above.
2. Place the rotor on a flat surface.
 - Rotors and adapters can be autoclaved at 121 °C.
 - The maximum permissible autoclave cycle is 20 minutes at 121 °C.

Clean the rotor before autoclaving and rinse it with distilled water. Remove all accessories (tubes, adapters) from the rotor. Place the rotor on a flat surface.

Note No chemical additives are permitted in the steam.



CAUTION Never exceed the permitted temperature and duration when autoclaving. If the rotor shows signs of corrosion or wear, it must be replaced.

Service of Thermo Fisher Scientific

Thermo Fisher Scientific recommends having the centrifuge and accessories serviced once a year by an authorized service technician. The service technicians check the following:

- the electrical equipment;
- the suitability of the set-up site;
- the lid lock and the safety system;
- the rotor;
- the fixation of the rotor and the drive shaft.

Thermo Fisher Scientific offers inspection and service contracts for this work.

RCF-Values

Table A-1. RCF-Values BIOLiner bucket

Speed (rpm)	R _{min}	R _{max}	RCF R _{min}	RCF R _{max}
300	10.5	20	11	20
400	10.5	20	19	36
500	10.5	20	29	56
600	10.5	20	42	80
700	10.5	20	58	110
800	10.5	20	75	143
900	10.5	20	95	181
1000	10.5	20	117	224
1100	10.5	20	142	271
1200	10.5	20	169	322
1300	10.5	20	198	378
1400	10.5	20	230	438
1500	10.5	20	264	503
1600	10.5	20	301	572
1700	10.5	20	339	646
1800	10.5	20	380	724
1900	10.5	20	424	807
2000	10.5	20	470	894
2100	10.5	20	518	986
2200	10.5	20	568	1082
2300	10.5	20	621	1183
2400	10.5	20	676	1288
2500	10.5	20	734	1398
2600	10.5	20	794	1512
2700	10.5	20	856	1630
2800	10.5	20	920	1753
2900	10.5	20	987	1880
3000	10.5	20	1057	2012

Speed (rpm)	R _{min}	R _{max}	RCF R _{min}	RCF R _{max}
3100	10.5	20	1128	2149
3200	10.5	20	1202	2290
3300	10.5	20	1278	2435
3400	10.5	20	1357	2585
3500	10.5	20	1438	2739

Table 2. RCF-Values Microplate Carrier

Speed (rpm)	Min. radius	Max. radius	RCF Rmin	RCF Rmax
300	10.5	17.9	11	18
400	10.5	17.9	19	32
500	10.5	17.9	29	50
600	10.5	17.9	42	72
700	10.5	17.9	58	98
800	10.5	17.9	75	128
900	10.5	17.9	95	162
1000	10.5	17.9	117	200
1100	10.5	17.9	142	242
1200	10.5	17.9	169	288
1300	10.5	17.9	198	338
1400	10.5	17.9	230	392
1500	10.5	17.9	264	450
1600	10.5	17.9	301	512
1700	10.5	17.9	339	578
1800	10.5	17.9	380	648
1900	10.5	17.9	424	722
2000	10.5	17.9	470	800
2100	10.5	17.9	518	883
2200	10.5	17.9	568	969
2300	10.5	17.9	621	1059
2400	10.5	17.9	676	1153
2500	10.5	17.9	734	1251
2600	10.5	17.9	794	1353
2700	10.5	17.9	856	1459
2800	10.5	17.9	920	1569
2900	10.5	17.9	987	1683
3000	10.5	17.9	1057	1801
3100	10.5	17.9	1128	1923

Speed (rpm)	Min. radius	Max. radius	RCF Rmin	RCF Rmax
3200	10.5	17.9	1202	2049
3300	10.5	17.9	1278	2179
3400	10.5	17.9	1357	2313
3500	10.5	17.9	1438	2451

Chemical Compatibility Chart

CHEMICAL	MATERIAL	ALUMINIUM	ANODIC COATING for ALUMINIUM	BUNA N	CELLULOSE ACETATE BUTYRATE	POLYURETHANE ROTOR PAINT	COMPOSITE Carbon Fiber/Epoxy	DELERIN®	ETHYLENE PROPYLENE	GLASS	NEOPRENE	NORYL®	NYLON	PET®, POLYCLEAR®, CLEARCRIMP®, OCCLEARCRIMP®	POLYALLOMER	POLYCARBONATE	POLYESTER, GLASS THERMOSET	POLYETHERIMIDE	POLYRTHYLENE	POLYPROPYLENE	POLYSULFONE	POLYVINYL CHLORIDE	RULON A®, TEFLON®	SILICONE RUBBER	STAINLESS STEEL	TITANIUM	TYGON®	VITON®	
2-mercaptoethanol		S	S	U	-	S	M	S	-	S	U	S	S	U	S	S	-	S	S	S	S	U	S	S	S	S	S	S	
Acetaldehyde		S	-	U	U	-	-	-	M	-	U	-	-	-	M	U	U	U	M	M	-	M	S	U	-	S	-	U	
Acetone		M	S	U	U	S	U	M	S	S	U	U	S	U	S	U	U	U	S	S	U	U	S	M	M	S	U	U	
Acetonitrile		S	S	U	-	S	M	S	-	S	S	U	S	U	M	U	U	-	S	M	U	U	S	S	S	S	U	U	
Alconox®		U	U	S	-	S	S	S	-	S	S	S	S	S	S	M	S	S	S	S	S	S	S	S	S	S	S	U	
Allyl Alcohol		-	-	-	U	-	-	S	-	-	-	-	S	-	S	S	M	S	S	S	S	-	M	S	-	-	S	-	
Aluminium Chloride		U	U	S	S	S	S	U	S	S	S	S	M	S	S	S	S	-	S	S	S	S	S	M	U	U	S	S	
Formic Acid (100 %)		-	S	M	U	-	-	U	-	-	-	-	U	-	S	M	U	U	S	S	-	U	S	-	U	S	-	U	
Ammonium Acetate		S	S	U	-	S	S	S	-	S	S	S	S	S	S	S	U	-	S	S	S	S	S	S	S	S	S	S	
Ammonium Carbonate		M	S	U	S	S	S	S	S	S	S	S	S	S	S	U	U	-	S	S	S	S	S	S	M	S	S	S	
Ammonium Hydroxide (10 %)		U	U	S	U	S	S	M	S	S	S	S	S	-	S	U	M	S	S	S	S	S	S	S	S	S	S	M	S
Ammonium Hydroxide (28 %)		U	U	S	U	S	U	M	S	S	S	S	S	U	S	U	M	S	S	S	S	S	S	S	S	S	S	M	S
Ammonium Hydroxide (conc.)		U	U	U	U	S	U	M	S	-	S	-	S	U	S	U	U	S	S	S	-	M	S	S	S	S	-	U	
Ammonium Phosphate		U	-	S	-	S	S	S	S	S	S	S	S	-	S	S	M	-	S	S	S	S	S	S	M	S	S	S	
Ammonium Sulfate		U	M	S	-	S	S	U	S	S	S	S	S	S	S	S	S	-	S	S	S	S	S	S	U	S	S	U	
Amyl Alcohol		S	-	M	U	-	-	S	S	-	M	-	S	-	M	S	S	S	S	M	-	-	-	U	-	S	-	M	
Aniline		S	S	U	U	S	U	S	M	S	U	U	U	U	U	U	U	-	S	M	U	U	S	S	S	S	U	S	
Sodium Hydroxide (<1 %)		U	-	M	S	S	S	-	-	S	M	S	S	-	S	M	M	S	S	S	S	S	S	M	S	S	-	U	
Sodium Hydroxide (10 %)		U	-	M	U	-	-	U	-	M	M	S	S	U	S	U	U	S	S	S	S	S	S	M	S	S	-	U	
Barium Salts		M	U	S	-	S	S	S	S	S	S	S	S	S	S	S	M	-	S	S	S	S	S	M	S	S	S	S	
Benzene		S	S	U	U	S	U	M	U	S	U	U	S	U	U	U	M	U	M	U	U	U	S	U	U	S	U	S	
Benzyl Alcohol		S	-	U	U	-	-	M	M	-	M	-	S	U	U	U	U	U	U	U	U	-	M	S	M	-	S	-	S

B Chemical Compatibility Chart

CHEMICAL	MATERIAL																										
	ALUMINIUM	ANODIC COATING for ALUMINIUM	BUNA N	CELULOSE ACETATE BUTYRATE	POLYURETHANE ROTOR PAINT	COMPOSITE Carbon Fiber/Epoxy	DELERIN®	ETHYLENE PROPYLENE	GLASS	NEOPRENE	NORYL®	NYLON	PET™, POLYCLEAR®, CLEARCRIMP®, OCCLEARCRIMP®	POLYALLOMER	POLYCARBONATE	POLYESTER, GLASS THERMOSET	POLYETHERIMIDE	POLYRTHYLENE	POLYPROPYLENE	POLYSULFONE	POLYVINYL CHLORIDE	RULON A®, TEFLON®	SILICONE RUBBER	STAINLESS STEEL	TITANIUM	TYGON®	VITON®
Boric Acid	U	S	S	M	S	S	U	S	S	S	S	S	S	S	S	S	U	S	S	S	S	S	S	S	S	S	S
Cesium Acetate	M	-	S	-	S	S	S	-	S	S	S	S	-	S	S	-	-	S	S	S	S	S	S	M	S	S	S
Cesium Bromide	M	S	S	-	S	S	S	-	S	S	S	S	S	S	S	-	-	S	S	S	S	S	S	M	S	S	S
Cesium Chloride	M	S	S	U	S	S	S	-	S	S	S	S	S	S	S	-	-	S	S	S	S	S	S	M	S	S	S
Cesium Formate	M	S	S	-	S	S	S	-	S	S	S	S	S	S	S	-	-	S	S	S	S	S	S	M	S	S	S
Cesium Iodide	M	S	S	-	S	S	S	-	S	S	S	S	S	S	S	-	-	S	S	S	S	S	S	M	S	S	S
Cesium Sulfate	M	S	S	-	S	S	S	-	S	S	S	S	S	S	S	-	-	S	S	S	S	S	S	M	S	S	S
Chloroform	U	U	U	U	S	S	M	U	S	U	U	M	U	M	U	U	U	M	M	U	U	S	U	U	U	M	S
Chromic Acid (10 %)	U	-	U	U	S	U	U	-	S	S	S	U	S	S	M	U	M	S	S	U	M	S	M	U	S	S	S
Chromic Acid (50 %)	U	-	U	U	-	U	U	-	-	-	S	U	U	S	M	U	M	S	S	U	M	S	-	U	M	-	S
Cresol Mixture	S	S	U	-	-	-	S	-	S	U	U	U	U	U	U	-	-	U	U	-	U	S	S	S	S	U	S
Cyclohexane	S	S	S	-	S	S	S	U	S	U	S	S	U	U	U	M	S	M	U	M	M	S	U	M	M	U	S
Deoxycholate	S	S	S	-	S	S	S	-	S	S	S	S	S	S	S	-	-	S	S	S	S	S	S	S	S	S	S
Distilled Water	S	S	S	S	S	S	S	S	S	S	S	S	S	S	S	S	S	S	S	S	S	S	S	S	S	S	S
Dextran	M	S	S	S	S	S	S	-	S	S	S	S	S	S	S	S	S	S	S	S	S	S	S	M	S	S	S
Diethyl Ether	S	S	U	U	S	S	S	U	S	U	U	S	U	U	U	U	U	U	U	U	U	S	S	S	S	M	U
Diethyl Ketone	S	-	U	U	-	-	M	-	S	U	-	S	-	M	U	U	U	M	M	-	U	S	-	-	S	U	U
Diethylpyrocarbonate	S	S	U	-	S	S	S	-	S	S	U	S	U	S	U	-	-	S	S	S	M	S	S	S	S	S	S
Dimethylsulfoxide	S	S	U	U	S	S	S	-	S	U	S	S	U	S	U	U	-	S	S	U	U	S	S	S	S	U	U
Dioxane	M	S	U	U	S	S	M	M	S	U	U	S	U	M	U	U	-	M	M	M	U	S	S	S	S	U	U
Ferric Chloride	U	U	S	-	-	-	M	S	-	M	-	S	-	S	-	-	-	S	S	-	-	-	M	U	S	-	S
Acetic Acid (Glacial)	S	S	U	U	S	S	U	M	S	U	S	U	U	U	U	U	M	S	U	M	U	S	U	U	S	-	U
Acetic Acid (5 %)	S	S	M	S	S	S	M	S	S	S	S	S	M	S	S	S	S	S	S	S	M	S	S	M	S	S	M
Acetic Acid (60 %)	S	S	U	U	S	S	U	-	S	M	S	U	U	M	U	S	M	S	M	S	M	S	M	U	S	M	U
Ethyl Acetate	M	M	U	U	S	S	M	M	S	S	U	S	U	M	U	U	-	S	S	U	U	S	M	M	S	U	U
Ethyl Alcohol (50 %)	S	S	S	S	S	S	M	S	S	S	S	S	U	S	U	S	S	S	S	S	S	S	S	M	S	M	U
Ethyl Alcohol (95 %)	S	S	S	U	S	S	M	S	S	S	S	U	S	U	-	S	S	S	M	S	S	S	U	S	M	U	
Ethylene Dichloride	S	-	U	U	-	-	S	M	-	U	U	S	U	U	U	U	U	U	U	-	U	S	U	-	S	-	S
Ethylene Glycol	S	S	S	S	S	S	S	S	S	S	S	S	-	S	U	S	S	S	S	S	S	S	S	M	S	M	S
Ethylene Oxide Vapor	S	-	U	-	-	U	-	-	S	U	-	S	-	S	M	-	-	S	S	S	U	S	U	S	S	S	U

CHEMICAL	MATERIAL																										
	ALUMINIUM	ANODIC COATING for ALUMINIUM	BUNA N	CELLULOSE ACETATE BUTYRATE	POLYURETHANE ROTOR PAINT	COMPOSITE Carbon Fiber/Epoxy	DELERIN®	ETHYLENE PROPYLENE	GLASS	NEOPRENE	NORYL®	NYLON	PET®, POLYCLEAR®, CLEARCRIMP®, CCLLEARCRIMP®	POLYALLUMER	POLYCARBONATE	POLYESTER, GLASS THERMOSET	POLYETHERIMIDE	POLYRTHYLENE	POLYPROPYLENE	POLYSULFONE	POLYVINYL CHLORIDE	RULON A®, TEFLON®	SILICONE RUBBER	STAINLESS STEEL	TITANIUM	TYGON®	VITON®
Ficoll-Hypaque®	M	S	S	-	S	S	S	-	S	S	S	S	-	S	S	-	S	S	S	S	S	S	S	M	S	S	S
Hydrofluoric Acid (10 %)	U	U	U	M	-	-	U	-	-	U	U	S	-	S	M	U	S	S	S	S	M	S	U	U	U	-	-
Hydrofluoric Acid (50 %)	U	U	U	U	-	-	U	-	-	U	U	U	U	S	U	U	U	S	S	M	M	S	U	U	U	-	M
Hydrochloric Acid (conc.)	U	U	U	U	-	U	U	M	-	U	M	U	U	M	U	U	U	-	S	-	U	S	U	U	U	-	-
Formaldehyde (40 %)	M	M	M	S	S	S	S	M	S	S	S	S	M	S	S	S	U	S	S	M	S	S	S	M	S	M	U
Glutaraldehyde	S	S	S	S	-	-	S	-	S	S	S	S	S	S	S	-	-	S	S	S	-	-	S	S	S	-	-
Glycerol	M	S	S	-	S	S	S	S	S	S	S	S	S	S	S	S	-	S	S	S	S	S	S	S	S	S	S
Guanidine Hydrochloride	U	U	S	-	S	S	S	-	S	S	S	S	S	S	S	-	-	S	S	S	S	S	S	U	S	S	S
Haemo-Sol®	S	S	S	-	-	-	S	-	S	S	S	S	S	S	S	-	-	S	S	S	S	S	S	S	S	S	S
Hexane	S	S	S	-	S	S	S	-	S	S	U	S	U	M	U	S	S	U	S	S	M	S	U	S	S	U	S
Isobutyl Alcohol	-	-	M	U	-	-	S	S	-	U	-	S	U	S	S	M	S	S	S	-	S	S	S	-	S	-	S
Isopropyl Alcohol	M	M	M	U	S	S	S	S	S	U	S	S	U	S	U	M	S	S	S	S	S	S	S	M	M	M	S
Iodoacetic Acid	S	S	M	-	S	S	S	-	S	M	S	S	M	S	S	-	M	S	S	S	S	S	M	S	S	M	M
Potassium Bromide	U	S	S	-	S	S	S	-	S	S	S	S	S	S	S	S	S	S	S	-	S	S	S	M	S	S	S
Potassium Carbonate	M	U	S	S	S	S	S	-	S	S	S	S	S	U	S	S	S	S	S	S	S	S	S	S	S	S	S
Potassium Chloride	U	S	S	-	S	S	S	S	S	S	S	S	S	S	-	S	S	S	S	S	S	S	U	S	S	S	S
Potassium Hydroxide (5 %)	U	U	S	S	S	S	M	-	S	S	S	S	-	S	U	S	S	S	S	S	S	M	U	M	S	U	
Potassium Hydroxide (conc.)	U	U	M	U	-	-	M	-	M	S	S	-	U	M	U	U	U	S	M	-	M	U	-	U	U	-	U
Potassium Permanganate	S	S	S	-	S	S	S	-	S	S	U	S	S	S	M	-	S	M	S	U	S	S	M	S	U	S	S
Calcium Chloride	M	U	S	S	S	S	S	S	S	S	S	S	S	S	M	S	-	S	S	S	S	S	S	M	S	S	S
Calcium Hypochlorite	M	-	U	-	S	M	M	S	-	M	-	S	-	S	M	S	-	S	S	S	M	S	M	U	S	-	S
Kerosene	S	S	S	-	S	S	S	U	S	M	U	S	U	M	M	S	-	M	M	M	S	S	U	S	S	U	S
Sodium Chloride (10 %)	S	-	S	S	S	S	S	S	-	-	-	S	S	S	S	S	-	S	S	S	S	-	S	S	M	-	S
Sodium Chloride (sat'd)	U	-	S	U	S	S	S	-	-	-	-	S	S	S	S	S	-	S	S	-	S	-	S	S	M	-	S
Carbon Tetrachloride	U	U	M	S	S	U	M	U	S	U	U	S	U	M	U	S	S	M	M	S	M	M	M	M	U	S	S
Aqua Regia	U	-	U	U	-	-	U	-	-	-	-	-	U	U	U	U	U	U	U	-	-	-	-	-	S	-	M
Solution 555 (20 %)	S	S	S	-	-	-	S	-	S	S	S	S	S	S	S	-	-	S	S	S	-	S	S	S	S	S	S
Magnesium Chloride	M	S	S	-	S	S	S	S	S	S	S	S	S	S	S	S	S	S	S	S	S	S	S	M	S	S	S
Mercaptoacetic Acid	U	S	U	-	S	M	S	-	S	M	S	U	U	U	U	-	S	U	U	S	M	S	U	S	S	S	S
Methyl Alcohol	S	S	S	U	S	S	M	S	S	S	S	S	U	S	U	M	S	S	S	S	S	S	M	S	M	U	U

B Chemical Compatibility Chart

CHEMICAL	MATERIAL																												
	ALUMINIUM	ANODIC COATING for ALUMINIUM	BUNA N	CELULOSE ACETATE BUTYRATE	POLYURETHANE ROTOR PAINT	COMPOSITE Carbon Fiber/Epoxy	DELERIN®	ETHYLENE PROPYLENE	GLASS	NEOPRENE	NORYL®	NYLON	PET®, POLYCLEAR®, CLEARCRIMP®, OCCLEARCRIMP®	POLYALLOMER	POLYCARBONATE	POLYESTER, GLASS THERMOSET	POLYETHERIMIDE	POLYRTHYLENE	POLYPROPYLENE	POLYSULFONE	POLYVINYL CHLORIDE	RULON A®, TEFLON®	SILICONE RUBBER	STAINLESS STEEL	TITANIUM	TYGON®	VITON®		
Methylene Chloride	U	U	U	U	M	S	S	U	S	U	U	S	U	U	U	U	U	M	U	U	U	S	S	M	U	S	U		
Methyl Ethyl Ketone	S	S	U	U	S	S	M	S	S	U	U	S	U	S	U	U	U	S	S	U	U	S	S	S	S	S	U	U	
Metrizamide®	M	S	S	-	S	S	S	-	S	S	S	S	-	S	S	-	-	S	S	S	S	S	S	M	S	S	S	S	
Lactic Acid (100 %)	-	-	S	-	-	-	-	-	-	M	S	U	-	S	S	S	M	S	S	-	M	S	M	S	S	-	S	S	
Lactic Acid (20 %)	-	-	S	S	-	-	-	-	-	M	S	M	-	S	S	S	S	S	S	S	M	S	M	S	S	-	S	S	
N-Butyl Alcohol	S	-	S	U	-	-	S	-	-	S	M	-	U	S	M	S	S	S	S	M	M	S	M	-	S	-	S	S	
N-Butyl Phthalate	S	S	U	-	S	S	S	-	S	U	U	S	U	U	U	M	-	U	U	S	U	S	M	M	S	U	S	S	
N, N-Dimethylformamide	S	S	S	U	S	M	S	-	S	S	U	S	U	S	U	U	-	S	S	U	U	S	M	S	S	S	U	U	
Sodium Borate	M	S	S	S	S	S	S	S	S	S	S	U	S	S	S	S	-	S	S	S	S	S	S	M	S	S	S	S	
Sodium Bromide	U	S	S	-	S	S	S	-	S	S	S	S	S	S	S	S	-	S	S	S	S	S	S	M	S	S	S	S	
Sodium Carbonate (2 %)	M	U	S	S	S	S	S	S	S	S	S	S	S	S	U	S	S	S	S	S	S	S	S	S	S	S	S	S	
Sodium Dodecyl Sulfate	S	S	S	-	S	S	S	-	S	S	S	S	S	S	S	-	S	S	S	S	S	S	S	S	S	S	S	S	S
Sodium Hypochlorite (5 %)	U	U	M	S	S	M	U	S	S	M	S	S	S	M	S	S	S	S	M	S	S	S	M	U	S	M	S	S	
Sodium Iodide	M	S	S	-	S	S	S	-	S	S	S	S	S	S	S	-	-	S	S	S	S	S	S	M	S	S	S	S	
Sodium Nitrate	S	S	S	-	S	S	S	S	S	S	S	S	S	S	S	S	-	S	S	S	S	S	U	S	S	S	S	S	
Sodium Sulfate	U	S	S	-	S	S	S	S	S	S	S	S	S	S	S	S	S	S	S	S	S	S	S	M	S	S	S	S	
Sodium Sulfide	S	-	S	S	-	-	-	S	-	-	-	S	S	S	U	U	-	-	S	-	-	-	S	S	M	-	S	S	
Sodium Sulfite	S	S	S	-	S	S	S	S	M	S	S	S	S	S	S	M	-	S	S	S	S	S	S	S	S	S	S	S	
Nickel Salts	U	S	S	S	S	S	-	S	S	S	-	-	S	S	S	S	-	S	S	S	S	S	M	S	S	S	S	S	
Oils (Petroleum)	S	S	S	-	-	-	S	U	S	S	S	S	U	U	M	S	M	U	U	S	S	S	U	S	S	S	S	S	
Oils (Other)	S	-	S	-	-	-	S	M	S	S	S	S	U	S	S	S	S	U	S	S	S	S	-	S	S	M	S	S	
Oleic Acid	S	-	U	S	S	S	U	U	S	U	S	S	M	S	S	S	S	S	S	S	S	S	M	U	S	M	M	M	
Oxalic Acid	U	U	M	S	S	S	U	S	S	S	S	S	U	S	U	S	S	S	S	S	S	S	S	U	M	S	S	S	
Perchloric Acid (10 %)	U	-	U	-	S	U	U	-	S	M	M	-	-	M	U	M	S	M	M	-	M	S	U	-	S	-	S	S	
Perchloric Acid (70 %)	U	U	U	-	-	U	U	-	S	U	M	U	U	M	U	U	U	M	M	U	M	S	U	U	S	U	S	S	
Phenol (5 %)	U	S	U	-	S	M	M	-	S	U	M	U	U	S	U	M	S	M	S	U	U	S	U	M	M	M	S	S	
Phenol (50 %)	U	S	U	-	S	U	M	-	S	U	M	U	U	U	U	U	S	U	M	U	U	S	U	U	U	M	S	S	
Phosphoric Acid (10 %)	U	U	M	S	S	S	U	S	S	S	S	U	-	S	S	S	S	S	S	S	S	S	U	M	U	S	S	S	
Phosphoric Acid (conc.)	U	U	M	M	-	-	U	S	-	M	S	U	U	M	M	S	S	S	M	S	M	S	U	M	U	-	S	S	
Physiologic Media (Serum, Urine)	M	S	S	S	-	-	S	-	S	S	S	S	S	S	S	S	S	S	S	S	S	S	S	S	S	S	S	S	S

CHEMICAL	MATERIAL																										
	ALUMINIUM	ANODIC COATING for ALUMINIUM	BUNA N	CELLULOSE ACETATE BUTYRATE	POLYURETHANE ROTOR PAINT	COMPOSITE Carbon Fiber/Epoxy	DELERIN®	ETHYLENE PROPYLENE	GLASS	NEOPRENE	NORYL®	NYLON	PET*, POLYCLEAR®, CLEARCRIMP®, CCLLEARCRIMP®	POLYALLOMER	POLYCARBONATE	POLYESTER, GLASS THERMOSET	POLYETHERIMIDE	POLYRTHYLENE	POLYPROPYLENE	POLYSULFONE	POLYVINYL CHLORIDE	RULON A®, TEFLON®	SILICONE RUBBER	STAINLESS STEEL	TITANIUM	TYGON®	VITON®
Picric Acid	S	S	U	-	S	M	S	S	S	M	S	U	S	S	S	U	S	S	S	S	U	S	U	M	S	M	S
Pyridine (50 %)	U	S	U	U	S	U	U	-	U	S	S	U	U	M	U	U	-	U	S	M	U	S	S	U	U	U	U
Rubidium Bromide	M	S	S	-	S	S	S	-	S	S	S	S	S	S	S	-	-	S	S	S	S	S	S	M	S	S	S
Rubidium Chloride	M	S	S	-	S	S	S	-	S	S	S	S	S	S	S	-	-	S	S	S	S	S	S	M	S	S	S
Sucrose	M	S	S	-	S	S	S	S	S	S	S	S	S	S	S	S	S	S	S	S	S	S	S	S	S	S	S
Sucrose, Alkaline	M	S	S	-	S	S	S	-	S	S	S	S	S	S	U	S	S	S	S	S	S	S	S	M	S	S	S
Sulfosalicylic Acid	U	U	S	S	S	S	S	-	S	S	S	U	S	S	S	-	S	S	S	-	S	S	S	U	S	S	S
Nitric Acid (10 %)	U	S	U	S	S	U	U	-	S	U	S	U	-	S	S	S	S	S	S	S	S	S	M	S	S	S	S
Nitric Acid (50 %)	U	S	U	M	S	U	U	-	S	U	S	U	U	M	M	U	M	M	M	S	S	S	U	S	S	M	S
Nitric Acid (95 %)	U	-	U	U	-	U	U	-	-	U	U	U	U	M	U	U	U	U	M	U	U	S	U	S	S	-	S
Hydrochloric Acid (10 %)	U	U	M	S	S	S	U	-	S	S	S	U	U	S	U	S	S	S	S	S	S	S	S	U	M	S	S
Hydrochloric Acid (50 %)	U	U	U	U	S	U	U	-	S	M	S	U	U	M	U	U	S	S	S	S	M	S	M	U	U	M	M
Sulfuric Acid (10 %)	M	U	U	S	S	U	U	-	S	S	M	U	S	S	S	S	S	S	S	S	S	S	U	U	U	S	S
Sulfuric Acid (50 %)	M	U	U	U	S	U	U	-	S	S	M	U	U	S	U	U	M	S	S	S	S	S	U	U	U	M	S
Sulfuric Acid (conc.)	M	U	U	U	-	U	U	M	-	-	M	U	U	S	U	U	U	M	S	U	M	S	U	U	U	-	S
Stearic Acid	S	-	S	-	-	-	S	M	S	S	S	S	-	S	S	S	S	S	S	S	S	S	M	M	S	S	S
Tetrahydrofuran	S	S	U	U	S	U	U	M	S	U	U	S	U	U	U	-	M	U	U	U	U	S	U	S	S	U	U
Toluene	S	S	U	U	S	S	M	U	S	U	U	S	U	U	U	S	U	M	U	U	U	S	U	S	U	U	M
Trichloroacetic Acid	U	U	U	-	S	S	U	M	S	U	S	U	S	M	-	M	S	S	U	U	S	U	U	U	M	U	U
Trichloroethane	S	-	U	-	-	-	M	U	-	U	-	S	U	U	U	U	U	U	U	U	U	S	U	-	S	-	S
Trichloroethylene	-	-	U	U	-	-	-	U	-	U	-	S	U	U	U	U	U	U	U	U	U	S	U	-	U	-	S
Trisodium Phosphate	-	-	-	S	-	-	M	-	-	-	-	-	-	S	-	-	S	S	S	-	-	S	-	-	S	-	S
Tris Buffer (neutral pH)	U	S	S	S	S	S	S	-	S	S	S	S	S	S	S	S	S	S	S	S	S	S	S	S	S	S	S
Triton X-100®	S	S	S	-	S	S	S	-	S	S	S	S	S	S	S	S	S	S	S	S	S	S	S	S	S	S	S
Urea	S	-	U	S	S	S	S	-	-	-	-	S	S	M	S	S	S	S	S	-	S	S	S	M	S	-	S
Hydrogen Peroxide (10 %)	U	U	M	S	S	U	U	-	S	S	S	U	S	S	S	M	U	S	S	S	S	S	S	M	S	U	S
Hydrogen Peroxide (3 %)	S	M	S	S	S	-	S	-	S	S	S	S	S	S	S	M	S	S	S	S	S	S	S	S	S	S	S
Xylene	S	S	U	S	S	S	M	U	S	U	U	U	U	U	U	M	U	M	U	U	U	S	U	M	S	U	S
Zinc Chloride	U	U	S	S	S	S	U	S	S	S	S	S	S	S	S	S	S	S	S	S	S	S	S	U	S	S	S

B Chemical Compatibility Chart

CHEMICAL	MATERIAL	ALUMINIUM	ANODIC COATING for ALUMINIUM	BUNA N	CELLULOSE ACETATE BUTYRATE	POLYURETHANE ROTOR PAINT	COMPOSITE Carbon Fiber/Epoxy	DELERIN®	ETHYLENE PROPYLENE	GLASS	NEOPRENE	NORYL®	NYLON	PET*, POLYCLEAR®, CLEARCRIMP®, OCCLEARCRIMP®	POLYALLOMER	POLYCARBONATE	POLYESTER, GLASS THERMOSET	POLYETHERIMIDE	POLYRTHYLENE	POLYPROPYLENE	POLYSULFONE	POLYVINYL CHLORIDE	RULON A®, TEFLON®	SILICONE RUBBER	STAINLESS STEEL	TITANIUM	TYGON®	VITON®
Zinc Sulfate		U	S	S	-	S	S	S	S	S	S	S	S	S	S	S	S	S	S	S	S	S	S	S	S	S	S	S
Citric Acid (10 %)		M	S	S	M	S	S	M	S	S	S	S	S	S	S	S	S	M	S	S	S	S	S	S	S	S	S	S

* Polyethyleneterephthalate

Key

- S Satisfactory
- M Moderate attack, may be satisfactory for use in centrifuge depending on length of exposure, speed involved, etc.; suggest testing under actual conditions of use.
- U Unsatisfactory, not recommended.
- Performance unknown; suggest testing, using sample to avoid loss of valuable material.

Chemical resistance data is included only as a guide to product use. Because no organized chemical resistance data exists for materials under the stress of centrifugation, when in doubt we recommend pretesting sample lots.

Index

A		
Accessories	2-1	
Aerosol-tight Applications	5-1	
Aerosol-tight Closure with ClickSeal	5-3	
Aerosol-tight Rotors	3-3	
Autoclaving	6-5	
AutoLock™	3-1	
B		
Basic Principles	5-2	
Before a Run	4-2	
C		
Care	6-1	
Checking the aerosol Tightness	5-2	
Chemical Compatibility Chart	B-1	
Cleaning	6-2	
Cleaning Intervals	6-2	
Cycle Counter	4-3	
D		
Decontamination	6-4	
Disinfection	6-3	
F		
Fill Level	5-2	
Foreword	iii	
I		
Improper Loading	4-3	
M		
Maintenance and Care	6-1	
		Maximum Loading
		4-3
P		
Precautions	iii	
Proper Loading	4-2	
R		
RCF-Values	A-1	
RCF-Values BIOLiner bucket	A-1	
RCF-Values Microplate Carrier	A-2	
Removing the Rotor	3-3	
Rotor Installation	3-2	
Rotor Loading	4-1	
Rotor Specifications	1-1	
S		
Scope of Supply	iii	
Service	6-5	



Thermo Electron LED GmbH

Zweigniederlassung Osterode
Am Kalkberg, 37520 Osterode am Harz
Germany

thermofisher.com/rotors

© 2009-2020 Thermo Fisher Scientific Inc. All rights reserved.

All trademarks are the property of Thermo Fisher Scientific Inc. and its subsidiaries unless otherwise indicated.

Delrin, TEFLON, and Viton are registered trademarks of DuPont. Noryl is a registered trademark of SABIC. POLYCLEAR is a registered trademark of Hongye CO., Ltd. Hypaque is a registered trademark of Amersham Health As. RULON A and Tygon are registered trademarks of Saint-Gobain Performance Plastics. Alconox is a registered trademark of Alconox. Ficoll is a registered trademark of GE Healthcare. Haemo-Sol is a registered trademark of Haemo-Sol. Triton is a registered trademark of Union Carbide Corporation. Valox is a registered trademark of General Electric Co.

Specifications, terms and pricing are subject to change. Not all products are available in all countries. Please consult your local sales representative for details.

Shown pictures within the manual are examples and may differ considering the set parameters and language. Pictures of the user interface within the manual are showing the English version as example.

Australia +61 39757 4300

Austria +43 1 801 40 0

Belgium +32 9 272 54 82

China +800 810 5118, +400 650 5118

France +33 2 2803 2180

Germany national toll free

0800 1 536 376

Germany international +49 6184 90 6000

India toll free +1800 22 8374

India +91 22 6716 2200

Italy +39 02 95059 552

Japan +81 3 5826 1616

Korea +82 2 2023 0600

Netherlands +31 76 579 55 55

New Zealand +64 9 980 6700

Nordic / Baltic / CIS countries

+358 10 329 2200

Russia +7 812 703 42 15, +7 495 739 76 41

Singapore +82 2 3420 8700

Spain / Portugal +34 93 223 09 18

Switzerland +41 44 454 12 12

UK / Ireland +44 870 609 9203

USA / Canada +1 866 984 3766

Other Asian Countries +852 3107 7600

Countries not listed +49 6184 90 6000

en

