



Product Code	Inlet pipework Ø (mm)	Outlet pipework Ø (mm)	Overall	Inlet	Cover	Approx Weight (kg)
			Depth A (mm)	Invert B (mm)	Depth C (mm)	
SS500160	160	160	1080	740	480	19
SS500225	225	225	1080	720	458	21

MODEL : SS500

OVERVIEW

The Silt Guard Range has been designed for the catchment and removal of silt and debris from the run off from impermeable and hard standing surface areas, such as: roofs, path and driveways, patios, car parks, roads and highways. Installation of a Silt Sentinel as part of a SuDS design, will provide effective primary treatment for the surface water run off, improving water quality downstream and in turn, helping prevent flooding.

APPLICATION

The SS500 Range is designed for installation upstream of medium to large volume, cellular/crate – attenuation systems, ponds, swales and irrigation systems.

DESCRIPTION

525mm diameter, factory built unit, delivered to site ready to install. Featuring a robust, impact resistant, rota moulded body with moulded pipe spigots that accommodate 160mm EN 1401 pipe fittings. There is an option of Ø225mm twinwall pipe connections (See Model: SS500225).

Integrally there is a removable silt basket under the inlet. The basket has a moulded handle /grip and is fitted with three circular screens, the screens help remove debris that may enter the unit. The filter basket is 25 kilos full, so is still a single person lift .

This unit comes with an A15 loading – circular access cover as standard.

The unit depth can be increased by use of extension risers - Product Code 500ER (Detailed opposite).

FEATURES & BENEFITS

- Single piece units, delivered ready to install, reducing installation time and costs
- Offers significant onsite savings against PCC and other traditional construction methods, as they need no construction or wet trades
- Eliminates wastage associated with in-situ construction
- Rota Moulded LLDPE base - chemical and impact resistant
- Pipework - moulded Ø160mm EN 1401 spigots with option of Ø225mm twinwall (As detailed opposite)
- Removeable filter basket with integrated debris screens
- Basket full -25 kg, allowing a single person lift
- Optional extension risers, offers deeper inverts to suit project requirements - effective height 235mm
- Supplied with A15 loading circular access cover
- B125 loading access covers are available as an option
- Simple maintenance

MODEL: SS500160

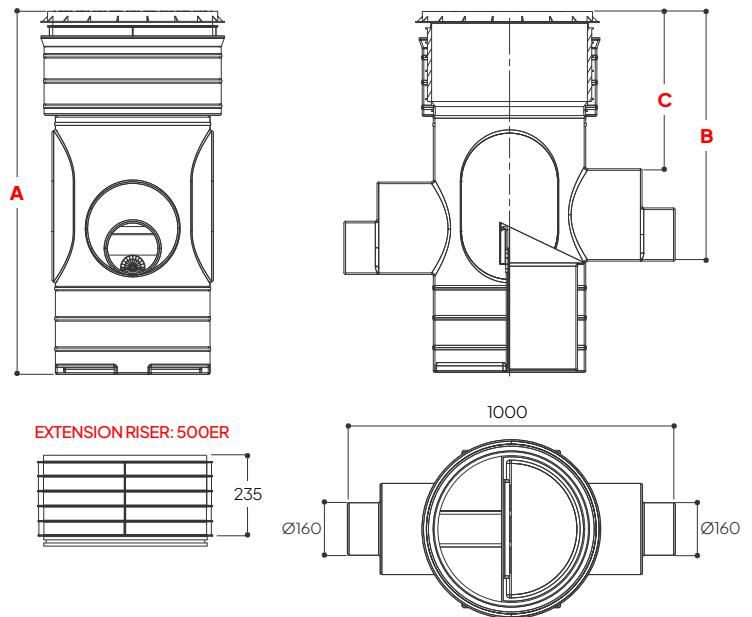

MODEL: SS500225

