

C SERIES - PROTECTED PLATE



MODEL: **OFCC1050**

Flow Control Chamber for use with 110mm to 450mm pipework diameters



OVERVIEW

The ORIFLO OFCC1050 is a protected orifice plate - flow control chamber. Designed to support SuDS management and the sewer infrastructure, as part of a designed attenuation system, helping prevent flooding by controlling the flow into the main sewer.

APPLICATION

Designed to be installed downstream of larger attenuation systems, i.e. tank and oversized pipe systems, forming the final part of the SuDS chain.

DESCRIPTION

1200 diameter, single piece - factory built units, delivered to site ready to install. Integrally there is a unique SILTBLOK filter and debris barrier. The barrier protects the orifice plate from being blocked, as well as protecting the downstream watercourse. All units feature an impact resistant, twinwall body, with a choice of main pipework diameters from 110mm EN 1401 to 450mm twinwall, with extra inlets available on request and a choice of positions from 120° to 240° (as shown in Plan View below). The number of extra inlets will be dependant on size of pipe and orientation. Chambers can be supplied with fitted ladder for full access, if required.

COMPLIANCE

- Design & Construction Guidance - April 2020. Section C7.12 - Flow Control Device
- Building Regulations - Part H1
- New DCG (Design and Construction Guidance) states; In Adoptable applications, this type of flow control device, is designed with a minimum 50mm orifice diameter



Orifice plates are manufactured to suit outlet pipework and can be changed easily if different orifice size is required

FEATURES & BENEFITS

- Single piece unit delivered ready to install, reducing installation time and costs
- Offers significant onsite savings against PCC and other traditional construction methods, as they need no construction or wet trades
- Eliminates wastage associated with in-situ construction
- Removable Orifice Plate
- Orifice Plate can be changed easily and extremely cost effectively, should the hydraulics and flow rates change due to future development
- Robust, chemical resistant- twinwall body
- Available in four depths
- Unique filter and debris barrier - manufactured from 100% recycled plastic
- Large range of pipework options available from 110mm EN 1401 to 450mm twinwall
- Option of fitted ladders
- Relatively Lightweight compared to traditional construction methods
- Access shafts can be trimmed to suit required invert
- 500mm sump depth for catchment of suspended fines
- Can be installed in granular backfill
- 60 year Design Life
- Manufactured in the UK

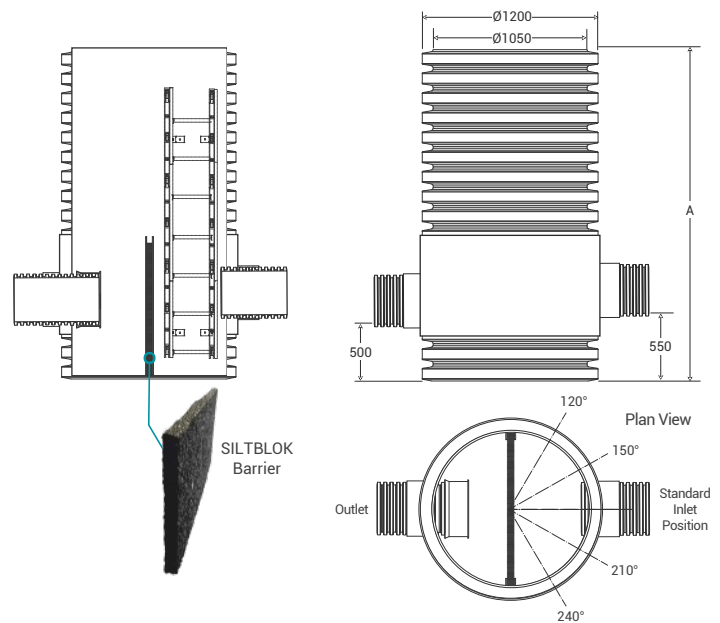

Product Code	Outlet pipework Ø mm	Optional Inlets Ø mm	Overall Depth A mm	Invert inlet B mm	Approx. Weight kg
OFCC1050/1.5	110 - 450	110 - 450	1465	915	135
OFCC1050/2	110 - 450	110 - 450	1983	1433	160
OFCC1050/2.5	110 - 450	110 - 450	2496	1946	185
OFCC1050/3	110 - 450	110 - 450	3016	2466	210

Please Note: The orifice plates in these units can be removed but the unit would need access ladders or fitted ladder to enter chamber



.. To calculate the specific orifice diameter from a prescribed restricted flow rate, you can use the flow rate calculator on our website: www.turtleenviro.co.uk/oriflo