



Rainwater Harvesting



Installation and maintenance instructions

AA Silentio Rainwater Harvesting System

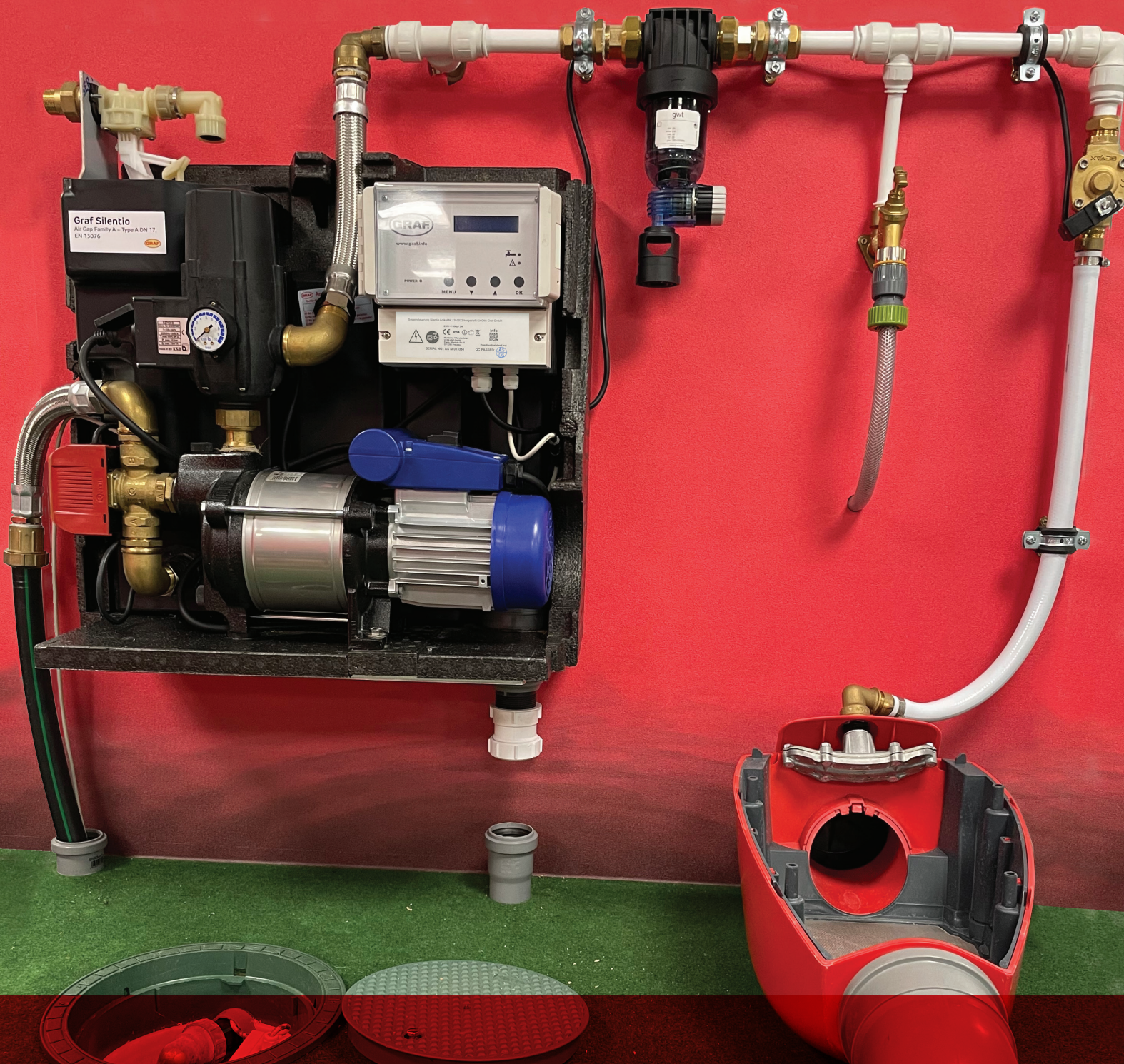

1. GENERAL NOTES

The points described in these instructions must be followed correctly. If not correctly observed, any right to claim on the warranty may be refused.

Any missing instructions must be requested directly from us.

A complete check of all the items/components for possible damage must be carried out before the assembly or installation begins.

The installation must be carried out in a professional manner.

Safety

The relevant accident prevention regulations according to BGV C22 must be observed during all works.

Furthermore, when carrying out assembly and installation work, inspection, maintenance and repairs, all work regulations and norms must be followed. You will find the advice in the appropriate sections of these instructions.

The installation of the system and/or single equipment parts must be carried out by a professional worker. The complete system must always be out of operation and guarded against unauthorized use when carrying out work on the plant or parts of the system.

Certain parts of the system are under electrical voltage and must not be opened. Working on the electrical system may only be carried out by a professional electrician.

All electrical wiring and connections must be in faultless condition. If damaged, the system may under no circumstances be brought into operation.

In case of damage, the equipment may lose water. The equipment may fall, so it is important to check that the wall material and the fixing brackets are adequate for the load.

The use of accessories that have not been approved by Graf results in the exclusion of warranty.

Identification obligation

THE WATER IN THESE SYSTEMS IS NOT SUITABLE FOR CONSUMPTION OR PERSONAL HYGIENE.

All pipe work and outlets of the water systems are to be labelled with the words "NOT DRINKING WATER" either in words or graphically so that after years of use, an accidental connection to the drinking water system is prevented. Even when correctly labelled it may be possibly mistaken, for example by children. For this reason, all the outlets of the systems process water must be fitted with child-proof locks.

2. APPLICATION

The AA Silentio is a micro-processor-controlled management system for rainwater. It is intended for service water in private homes and small apartment developments. By using an automatic back-up supply from mains water that delivers water to the tank if required, the rainwater system guarantees supply of process water.

The process water may be used to water the garden, flush toilets and supply washing machines.

The AA Silentio must be installed in a frost free and dry environment that is above any flood levels. Further information regarding the systems specifications, assembly and operation are detailed in the following sections.

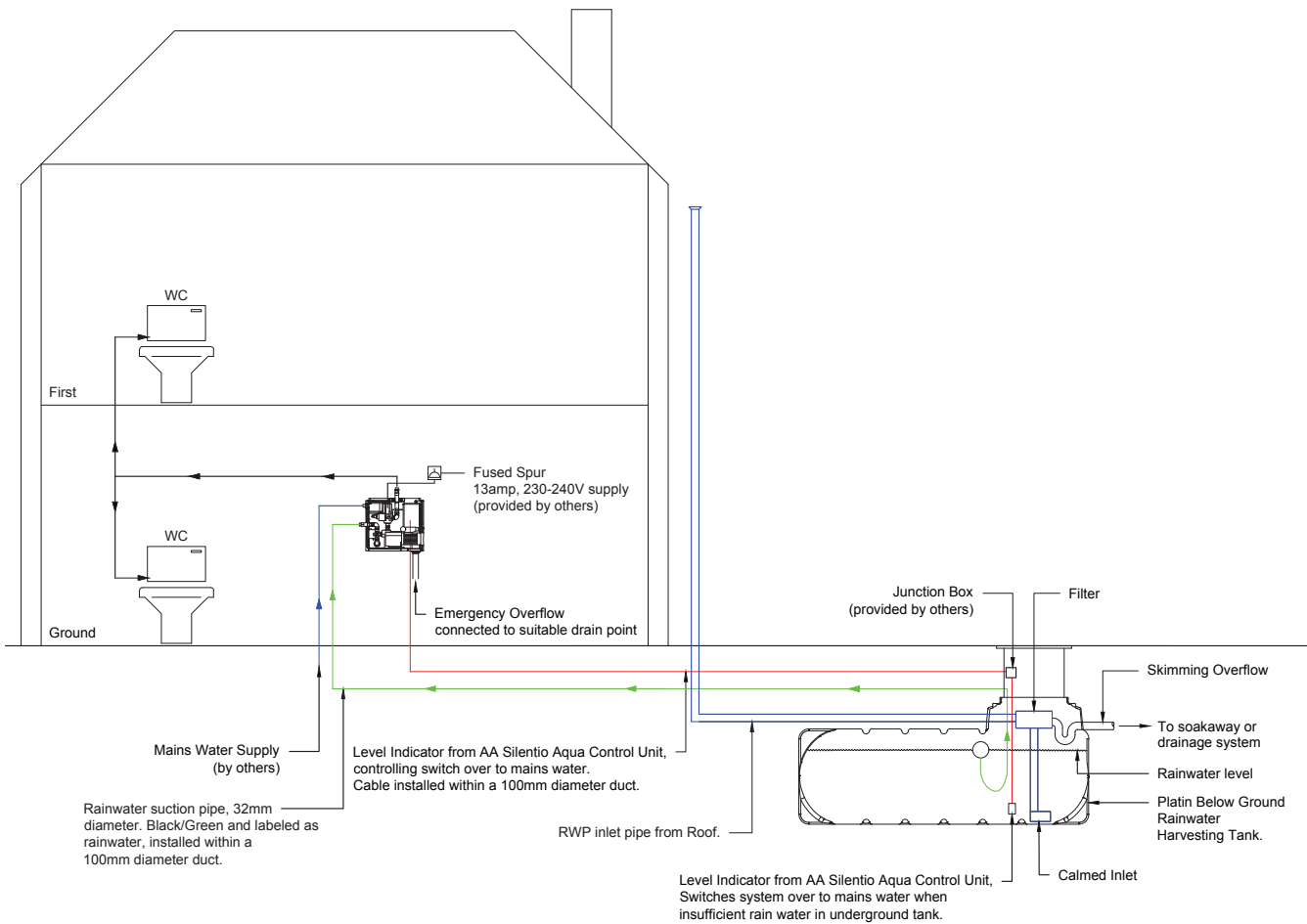

3. TECHNICAL DATA

Dimensions and weight

Weight: approx.. 26kg

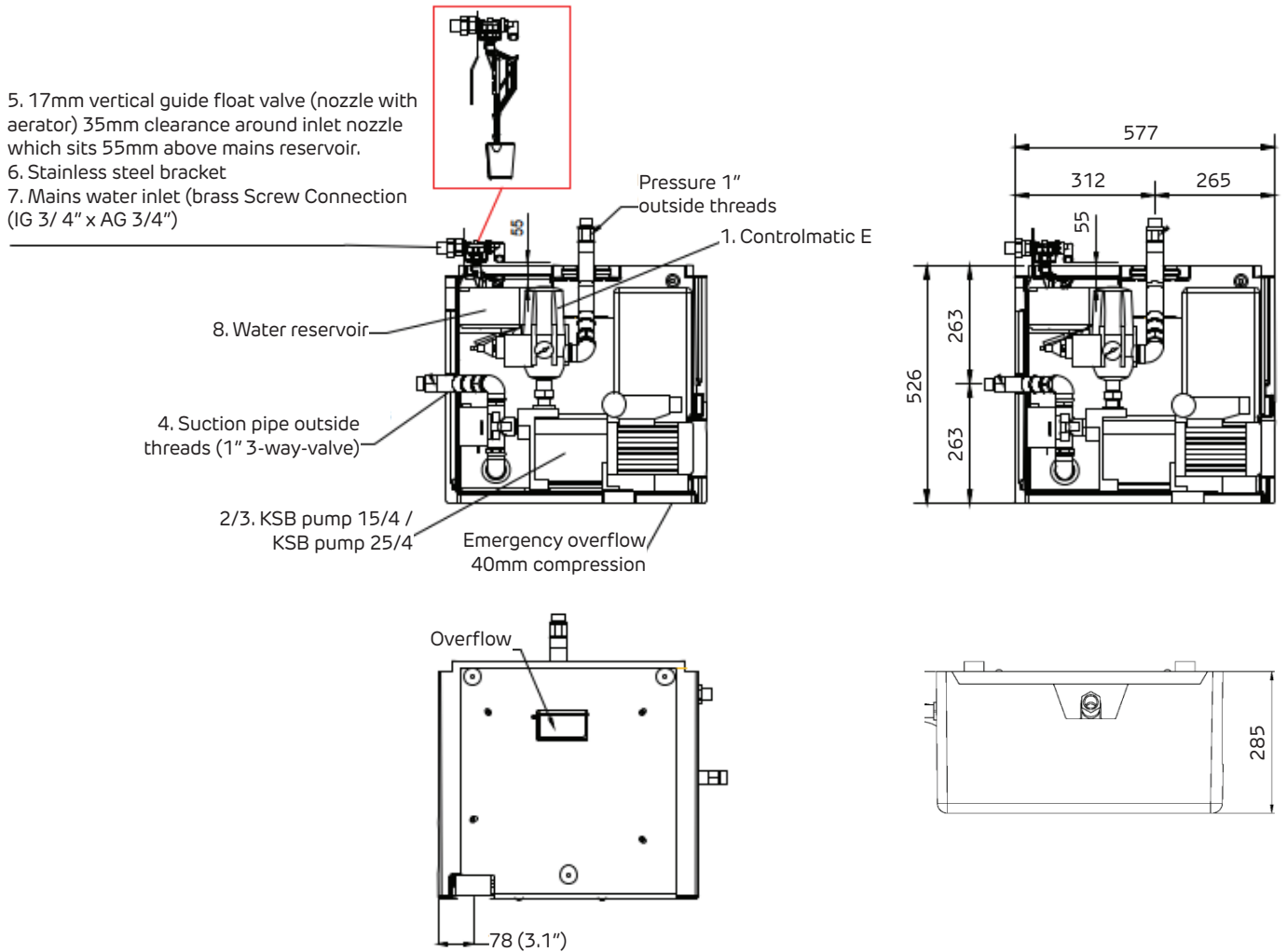

4. SYSTEM CONTROL

Float Valve	
Operating temperature	30° max.
Operating pressure	0.8-10 bar
Cv-value	50 l/min
Connections	¾" AG

3 Way Valve	
Voltage/Frequency	230 V / 50Hz
Output	6 W
Max. flow rate	16m ³ /h
Opening time	ca. 10 sec
Close time	ca. 5 sec
Max. pressure	10 bar
Allowable pressure differential	0.7 bar

Controlmatic (pressure and flow rate sensor)	
Voltage/Frequency	230 V / 50Hz
Protection classification	IP 44
Max. flow rate	10m ³ /h
Min. flow rate	0.1m ³ /h
Max. operating pressure	10 bar
Min. opening pressure	1.5 bar
Max. opening pressure	2.6 bar

Restarting after dry running the pump is possible by means of the "RESET" button.

If there is water pressure hammering in the system due to the rapid closing of valves (e.g. solenoid valve in the high pressure cleaner) then please contact Graf.

Pump	
Drive unit	Single phase AC motor 220-240 V / 50Hz with integrated overload protection IP 44, isolation class F.

AA Silentio 15/4	
Power requirement	660 W
Max. pump head height	35m
Max. pressure	3.5 bar
Max. pump discharge rate	3600 l/h
Max. suction height	6m
Max. suction length	15m

See diagram

4. SYSTEM CONTROL *continued*

AA Silentio 25/4

Power requirement	800 W
Max. pump head height	43m
Max. pressure	4,3 bar
Max. pump discharge rate	4200 l/h
Max. suction height	6m
Max. suction length	15m

See diagram

Suction height in relation to the suction length

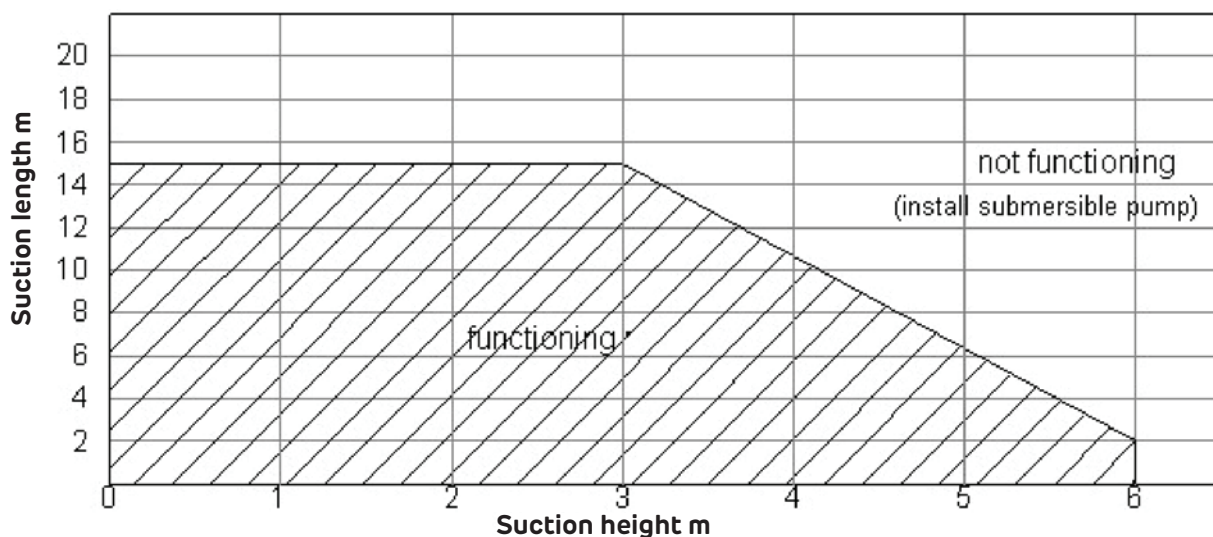

Pump discharge rate in relation to pump head height

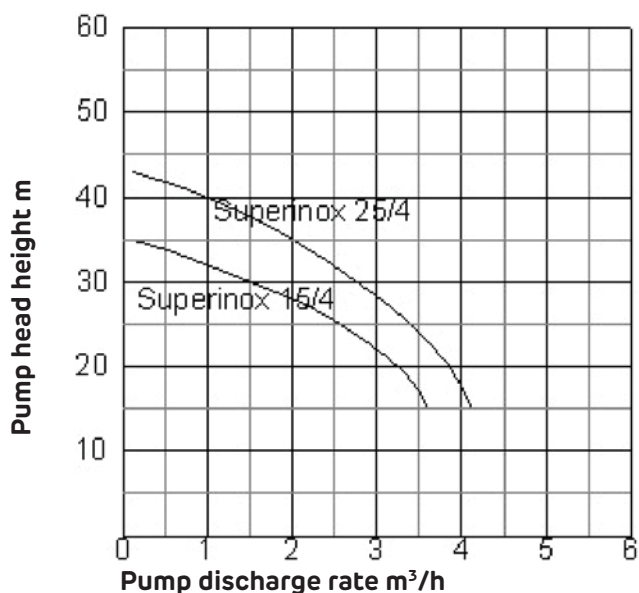

Pump Control Schematic

Figure 1

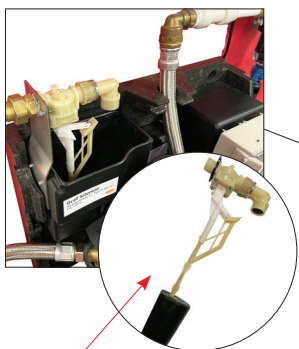

DN 17 (3/4") float valve

Braided hose

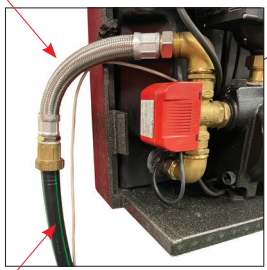

32mm black and green pipe

Floating intake

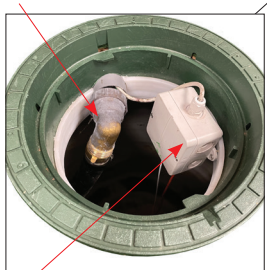

Level sensor with junction box

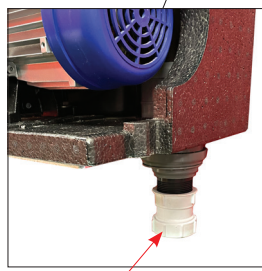

Emergency overflow - 40mm compression

19mm flexible hose

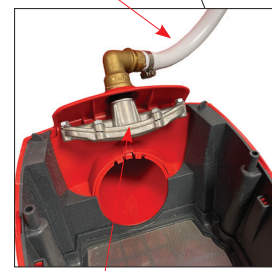

Optional Opticlean filter wash

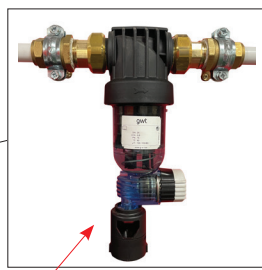

Optional 1" reversible flow filter



Optional 3/4" solenoid valve

Braided hose

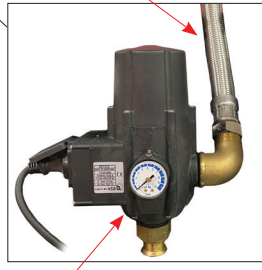

Controlmatic

5. INSTALLATION AND ASSEMBLY

Remove the AA Silentio from its transport packaging. The parts and accessories will be in the same box.

Firstly, check all the equipment for any possible damage. Any damage must be reported before assembly and installation begins.

Wall assembly

The AA Silentio must be installed above the back surge level and in a frost free and dry environment that is above any possible regional flood levels.

When choosing a position for installation, it is important to be sure that there is at least 50cm free space available above the equipment for any maintenance or adjustment regulation. The wall intended for mounting must be suitable for supporting the equipment with an approximate max. weight of 45kg when filled with water.

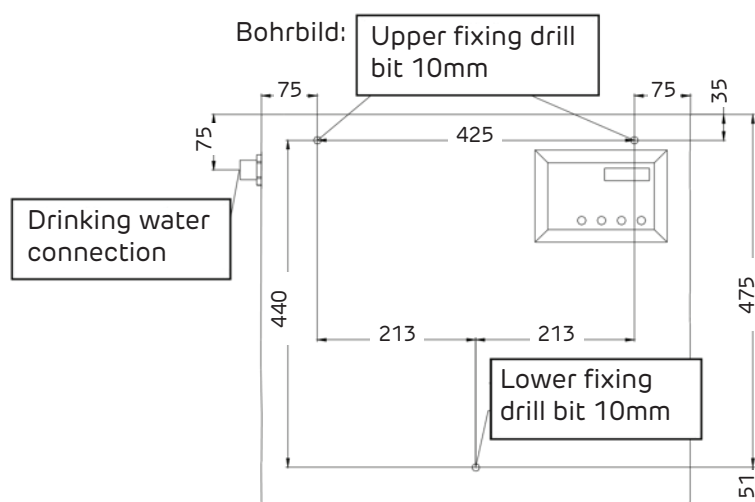

The holes to be drilled are marked out on the wall using the template and then drilled with a 10mm masonry bit, the holes should be approximately 60mm deep. Insert the enclosed dowel plugs and then screw in the stud bolts so that approximately 8mm remains protruding. Attach the two rubber buffers with the inside and outside threads to the two upper studs and attach the two rubber buffers with the double inside threads to the lower studs.

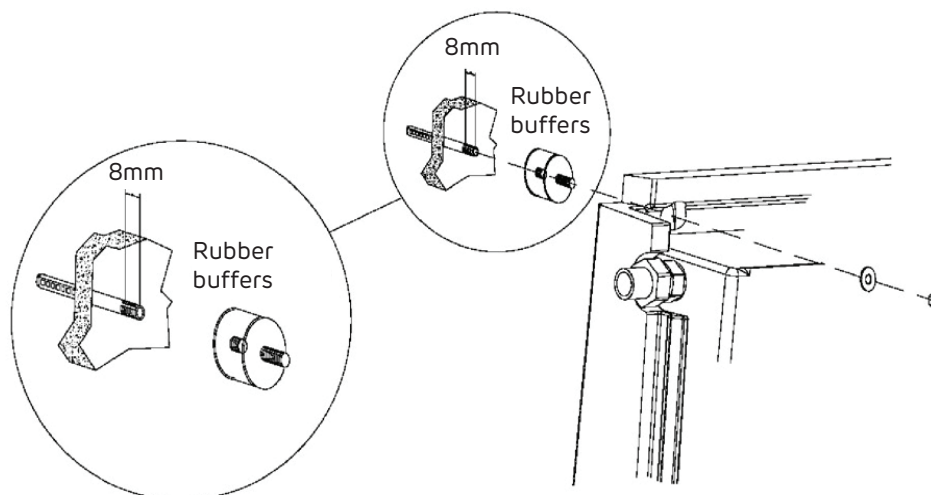

Emergency overflow connection

The emergency overflow connection is to be constructed with a 40mm waste pipe. In rooms with effective floor drains, it would be sufficient in the event of any overflowing water from the back-up unit, since under normal operating conditions, no water will overflow and an extra connection to the sewage canalisation is not required. If there is no floor drain, then it is necessary to install an emergency overflow that is connected to the drainage system.

Valve assembly

The DN 17 vertical guide float valve with aerator nozzle will come attached to the stainless steel bracket. The stainless steel bracket will have 4nr 6mm pre-drilled holes and is supplied with necessary nuts and bolts in situ.

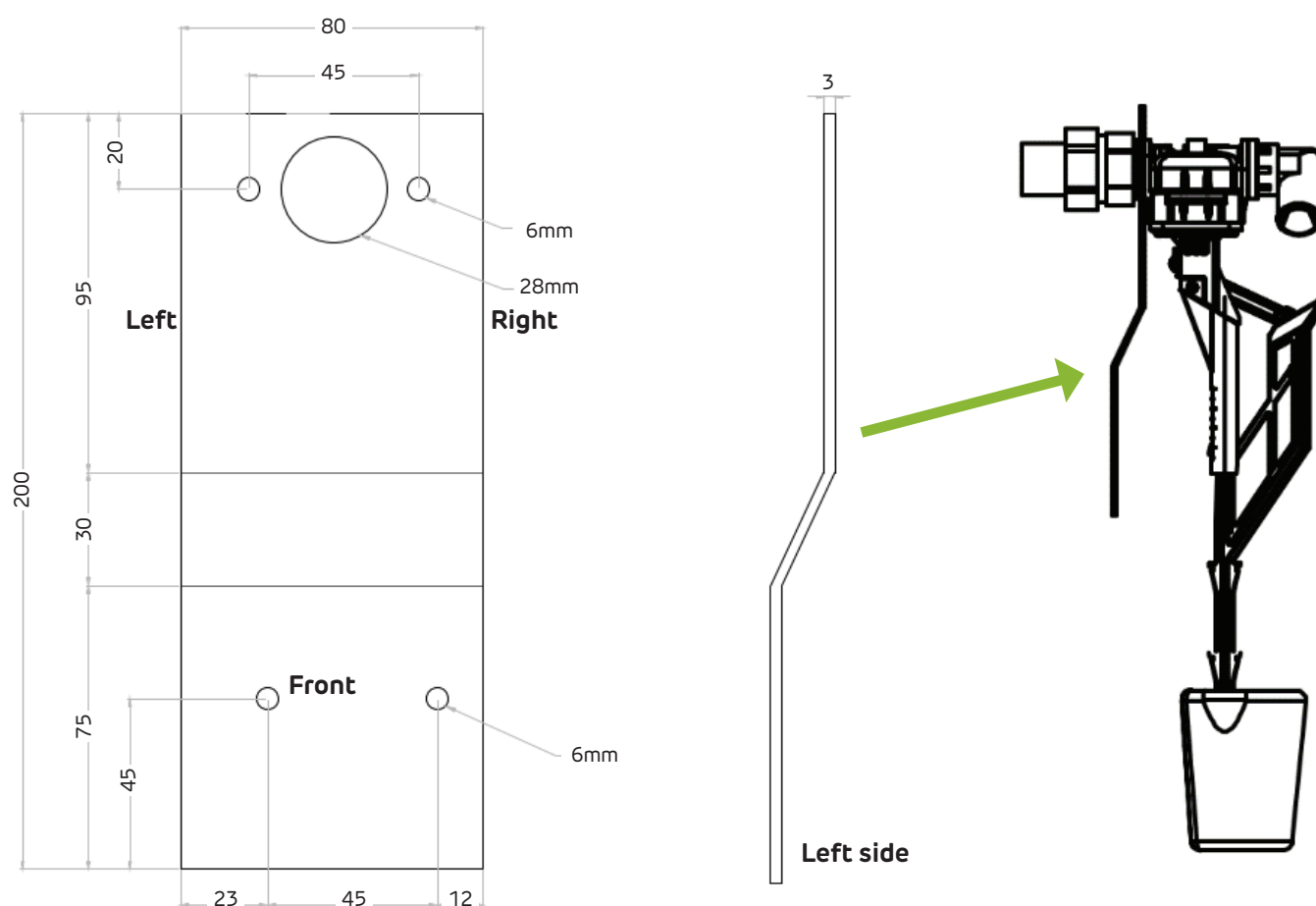

Remove the 2nr bottom bolts from the drill holes in the bracket and align the bracket with the holes on the left hand side of the mains water reservoir.

Once in place, secure the stainless steel bracket to the mains water reservoir using the nuts and bolts provided.

Note: you may need to temporarily remove the DN 17 vertical float valve from the bracket to fit the bracket to the mains water reservoir. Once complete, reattached the valve using the same fittings.

5. INSTALLATION AND ASSEMBLY *continued*

The inlet nozzle of the valve should sit 55mm above the top of the mains water reservoir tank.

There must be 35mm clearance around the inlet nozzle.

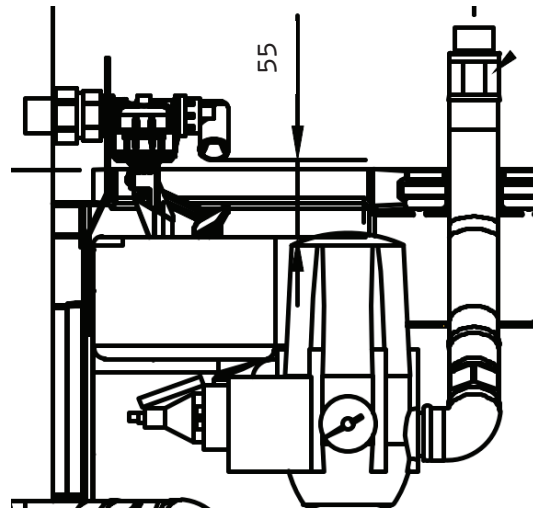

IT IS ESSENTIAL THAT THE VALVE ASSEMBLY IS EXACTLY AS ABOVE TO KEEP IN LIGN WITH BRITISH STANDARD EN 13076 – Devices to prevent pollution by backflow of potable water – Unrestricted air gap – Family A – Type A

Please check your system has been supplied with a 'Graf Silentio, Air Gap Family A – Type A DN 17, EN 13076' designation sticker on the front of the mains water reservoir tank. If this is missing, please contact Graf for a replacement.

Mains water connection

For connecting the float valve to the mains water supply we recommend using a $\frac{3}{4}$ " reinforced hose for the installation. **Take care when tightening the supply pipe that the valve does not twist. This will mean a problem free operation can no longer be guaranteed.** An additional shut-off valve will also make any future maintenance works less complicated.

Before the installation the mains water pipe system must be flushed through well. A fine filter should be installed to guarantee a long life and trouble free function of the float and 3 way valves.

Drinking water $\frac{3}{4}$ " outside threads



Suction pipe connection

A 32mm black and green suction pipe is installed in an empty conduit between the underground tank and the AA Silentio unit.

The connection to the AA Silentio back-up supply unit is by way of the 3 way valve which has at it's top a brass 90 degree elbow connection and the 1" braided hose with brass compression fitting supplied.

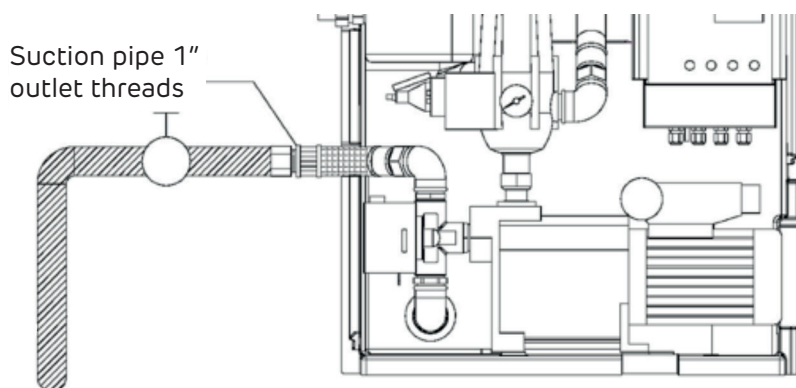

32mm black & green suction pipe

Pressure hose connection

Connect the pressure hose to the brass 90° elbow on the Controlmatic using the 2 enclosed 1" diameter reinforced hoses, these are then fed out through the top of the unit. A shut-off valve installed in the pressure line makes any future maintenance works less complicated.

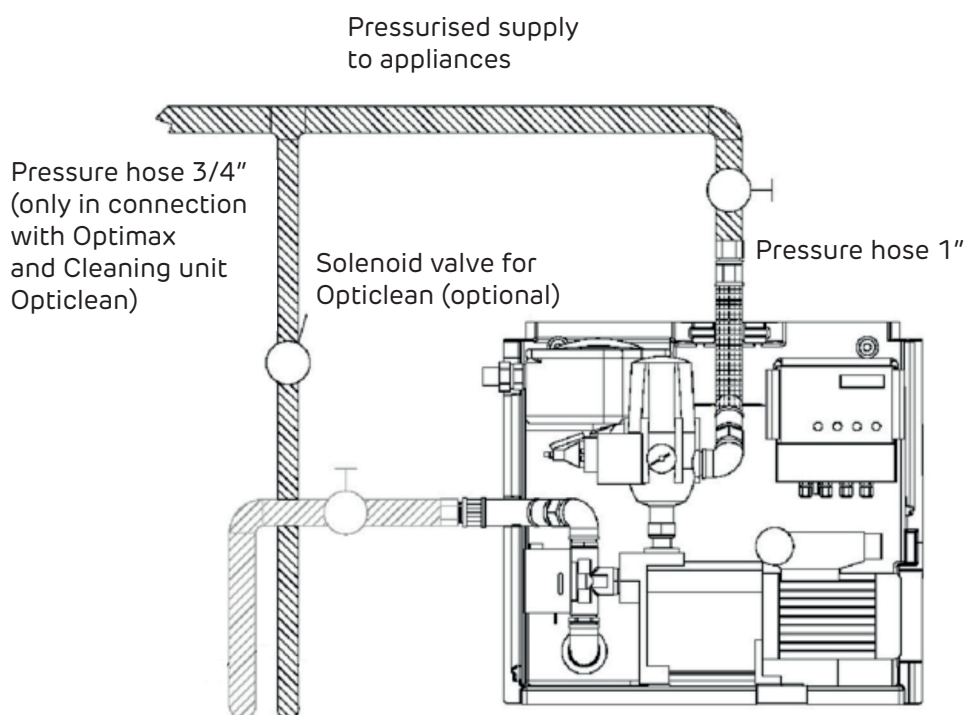

32mm black & green suction pipe



IMPORTANT – The optional reversible flow filter should be installed on the pressurised supply between the AA Silentio unit and the appliances.

5. INSTALLATION AND ASSEMBLY *continued*

Connection of optional Opticlean filter wash and solenoid valve



Solenoid Valve - to be installed on the pressurised line from the AA Silentio to the appliances (see figure 1 (page 7)). For electrical connection, see 'AA Silentio System Control' (page 13)

19mm flexible hose to connect Solenoid Valve to Opticlean Filter Wash via empty conduit.

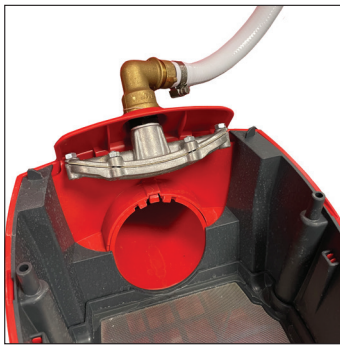

Opticlean Filter Wash - to be installed on the filter housing within the underground tank.

Optimax Filter (100mm connections)

Optimax XL Filter (150mm connections)

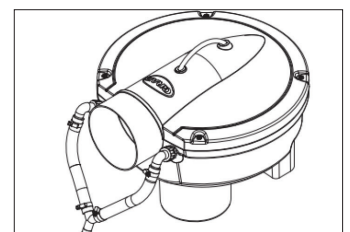
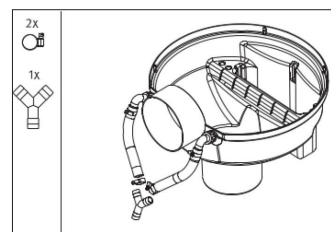
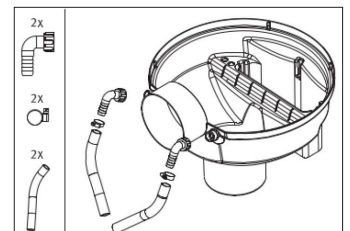
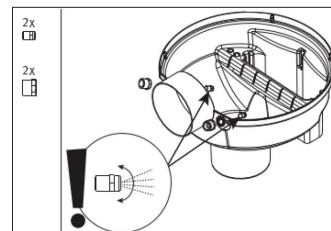
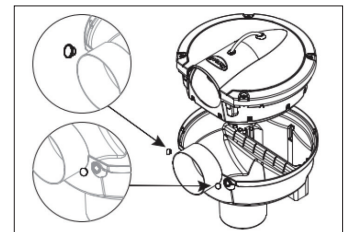
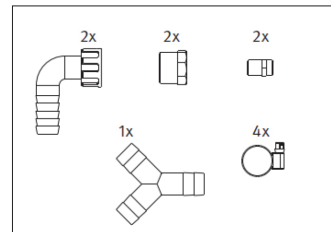
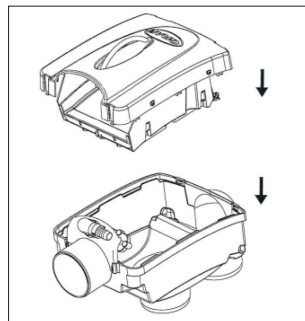
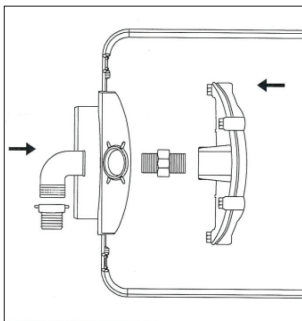
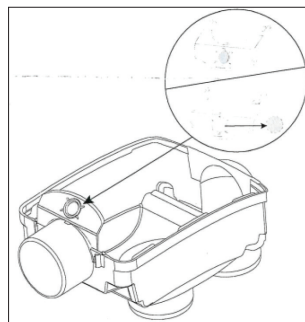
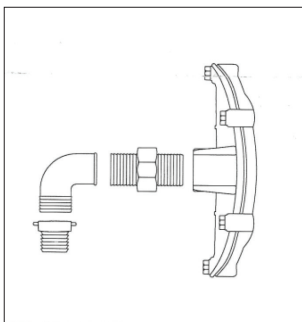

AA Silentio Control Panel

(For full details and safety information, see Silentio System Control guide).

Figure 2

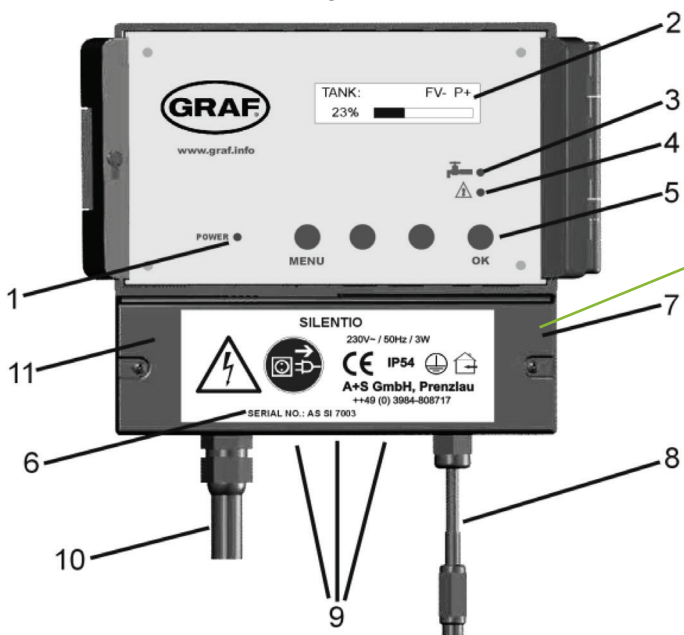
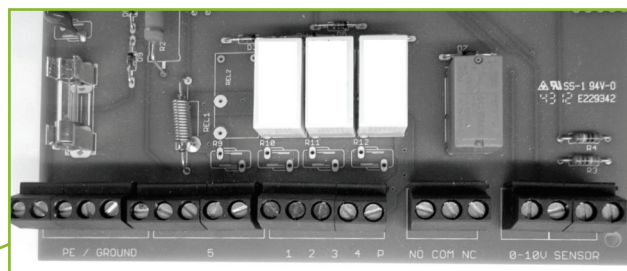

Figure 3



- 1. Pump
- 2. Power supply to additional pump
- 3. Power supply to filter flushing valve
- 4. Power supply to switch-over valve
- 5. Neutral conductor
- P. 230V AC
- PE / Ground: Earth

The AA Silentio has a grey mains power cable. This should be connected into a 13A switch fused spur.

- 6. Serial number
- 7. Lower cover of the system control
- 8. Main connection cable with power coupling for data lead
- 9. Pre-stamped breakthrough for upgrading features
- 10. Mains power coupling for data lead supply cable
- 11. The mains circuit breaker of the system controls are under this cover

Data cable and level sensor

The data cable is taken from the tank through the empty conduit to the AA Silentio unit and connected to the data lead coupling (8).

Figure 4

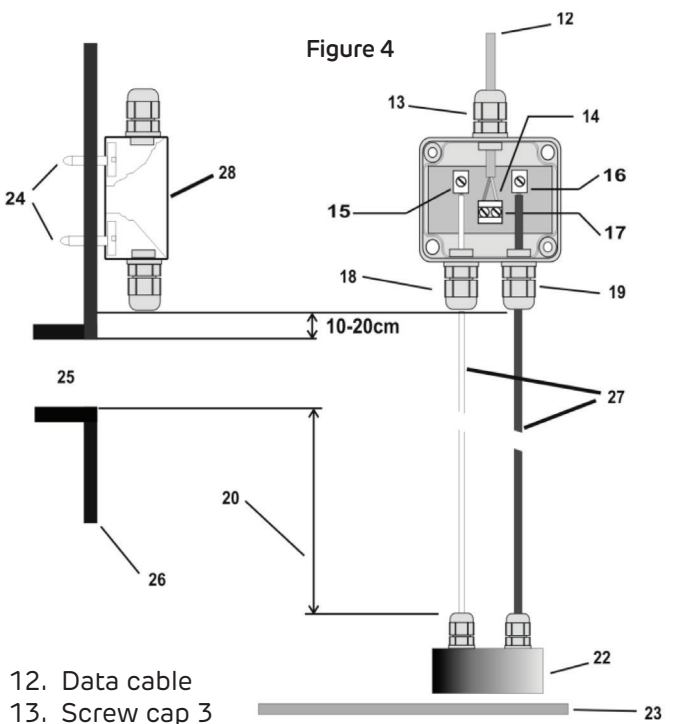

- 12. Data cable
- 13. Screw cap 3
- 14. Connection of the data cable is reverse protected
- 15. Connect white cable here
- 16. Connect red cable here
- 17. Data cable terminal
- 18. Screw cap 2
- 19. Screw cap 1
- 20. Active measuring length
- 21. Stainless steel probe
- 22. Tank floor
- 23. Screws must be blunted! (danger of injury)
- 24. Overflow
- 25. Tank side in dome
- 26. Sensor
- 27. Sensor control box (measurement pick-up)
- 28.

5. INSTALLATION AND ASSEMBLY *continued*

The sensor electronics comprise of a stainless steel probe (22) with a red and a white connecting cable (27) and the sensor measurement pick-up (28).

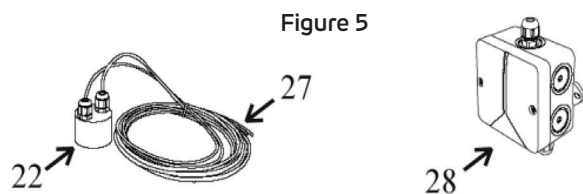

Figure 5

Figure 3: Sensor technology

1. Now the sensor measurement pick-up (28) (cover removed) should be installed on the tank wall (preferably in the man hole shaft of the Graf synthetic tank). The location of the mounted sensor pick-up should be between 10 and 15 cm above the overflow (25). The enclosed screws should be used to secure the device. After fully tightening the screws, the points that are showing themselves on the outside of the tank must be blunted to avoid injury (24).
2. Measure the height from the bottom of the tank (23) to the end of the terminals (15) and (16) on the measurement pick-up (28).
3. Shorten the connection cable to suit the measured height.
4. Connect the sensor to the sensor as described in the following instructions: Remove between 5-7mm of the insulation from both of the cables. Next, pass the red cable through the screw mounting 1 (19) and tighten this lightly, then connect the red cable to the terminal (16). The free white cable is now passed through the screw mounting 2 (18) and tightened lightly, then connect the white cable to the terminal (15).
5. Now pass the end of the data cable that has no plug connector (12) through the screw mounting 3 (13). Lightly tighten the screw mounting and connect the cable wire cores of the data cable (12) to the double terminal (14). The connection of the data cable is reverse polarity protected. **Attention! The screws should be tightened with care to ensure that they are not damaged through over tightening.**
6. Now re-check that all the screwed items and the sensor components have been fitted correctly. Replace the cover of the measurement pick-up and secure this with the appropriate fastening screws.
7. The installation of the data cable (12) to the system control must be according to good professional practice to constitute a correct completion of the sensor technology: A protective cable conduit must be used. (The data cable is not suitable for installing directly in the earth).
The end of the data cable that is still unconnected is fitted with a plug connector. This is to be plugged into the appropriate socket (8) of the system control.

Note:

The red and white cable going down to the probe should be straight and smooth to be drawn taught by the weight of the stainless steel probe. The stainless steel probe must hang just above the tank floor.

Optional additional booster pump

NOTE:- A booster pump is required where the AA Silentio unit is > 15m away from the underground tank.

The pump is installed within the underground tank connected to the floating intake hose using the fittings provided.

The ball float is clipped to the handle of the pump to allow the pump to float up and down within the tank.

The power cable for the pump must be connected to the AA Silentio control panel (see figure 3).



6. COMMISSIONING

Before the commissioning of the system, all the inlet and outlet pipes must be thoroughly rinsed through. Small foreign objects up to 2mm can cause substantial damage to pumps and other equipment.

Never run pumps without water in the system!

Remove the threaded fill plug from the pumps' body and completely fill the housing with water. Then fill the suction pipe with water. To do this, the cistern side end of a pipe is connected to the suction pipe (remove the basket) and an outlet in the house is opened. Be sure that the red 3 way valve is set to automatic [A]. By opening the inlet valve on the filling hose the complete system is filled with water until the water emerges free of air bubbles.

With this method the system is reliably bled of air and is now ready for operation. Now make the electric connection to the mains plug (230 V / Fused 16 A) and the system will be running. If the pump does not run or cuts out after a short time, then press the reset button on the controlmatic. This procedure is to be repeated until the water emerges without air bubbles at the outlet which is then closed, the pump will reach it's maximum pressure and stop automatically.

If it is not possible to fill the suction pipe with this method then it is also possible to fill it at the AA Silentio unit, to do this, the flow valve of the suction pipe in the tank must be opened. The filling must continue until the water emerges at the cistern end. The system may now be put into operation as described above.

Finally, the commissioning is complete by opening the mains water supply to the back-up supply tank. This fills the tank and before the water flows out of the overflow the float valve must close off the inlet. If this does not happen then the polystyrene float that controls the valve must be adjusted.

(For details on commissioning of the control panel, see Silentio System Control guide.)

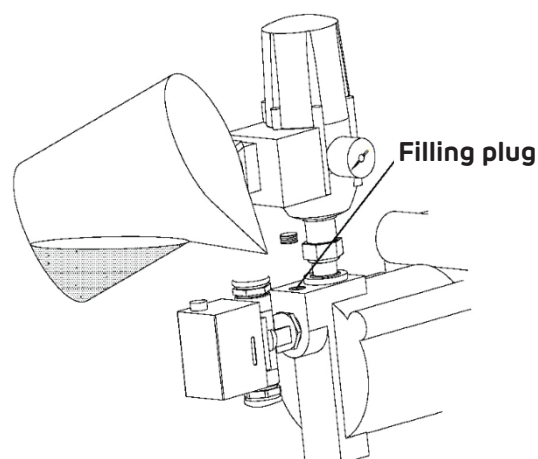

6. SERVICE AND CARE

Service

The complete system must be serviced at regular intervals (approx.. every 3 to 4 months). For every service all of the threaded connections must be checked for leaks. Also the condition of the function of the float valve for the back-up tank must be checked. If the system has been out of use for a long period of time or there has been the danger of frost, then the pump and controlmatic should be emptied. Any temporary storage should only be at a dry and well ventilated location.

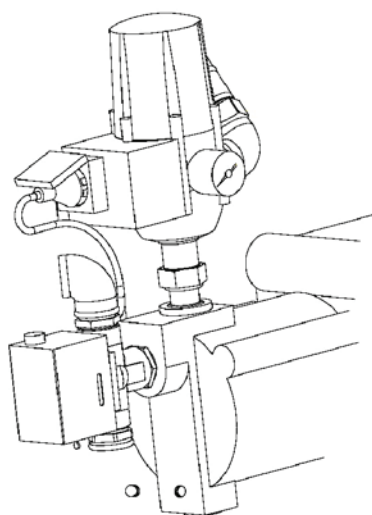

Emptying plug

Care

For care and cleaning of the system it is sufficient to use a damp cloth, for more thorough cleaning a mild detergent may also be used. Under no circumstances should a solvent or cleaning agents containing solvent be used.

7. FAULT FINDING AND CORRECTIVE ACTION

Fault	Cause	Action
Pump does not run	No electric power	Plug into or check the electrical supply
	Pump impeller jammed	Professional pump overhaul or service and cleaning
Pump does not draw	Suction valve is not in the water	Suction valve should be brought below the waters surface
	Pump impeller without water	Fill the system with water
	Air in suction pipe	Air bleed the system and check for leaks
	Blocked suction basket	Clean the suction basket
	Max. suction height or length of suction pipe has been exceeded	Check the suction height or change the pump position or use a submersible pump
Pump does not switch off	Possibly an outlet is open (water left running)	Close the outlet
	Pressure hose or outlet is leaking	Repair the leaking pressure hose or outlet
Pump discharge rate insufficient	Suction height too high	Check the suction height or change the pump position or use a submersible pump
	Blocked suction basket	Clean the suction basket
	Dirt in system equipment	Clean all system components and overhaul or service the pump (by a professional)
	Pump head height too high	Check the pump head height or change the pump position or use a larger pump
Thermal circuit breaker shuts down the pump	Overloading due to dirt in the motor housing	Professional pump overhaul or service and cleaning/Prevent the drawing in of dirt and foreign objects



RAINWATER HARVESTING

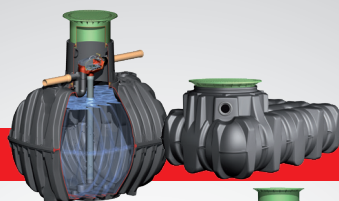

WASTEWATER MANAGEMENT



STORMWATER MANAGEMENT



WATER BUTTS & COMPOSTERS



MULTIPURPOSE CONTAINERS



Graf UK Ltd
Regen House
Beaumont Road
Banbury
Oxfordshire OX16 1RH

T: 01608 661500
F: 01295 211333
E: info@grafuk.co.uk
www.grafuk.co.uk

Graf UK Ltd (Scotland)
220 Blairtummock Road
Queenslie Industrial Estate
Glasgow
G33 4ED

T: 0141 465 1540
F: 01295 211333
E: info@grafuk.co.uk
www.grafuk.co.uk