

**STEP 1:** Carefully check box contents to the detail below, making sure all contents are accounted for.

If anything is missing, please contact Sharper Image Massage Chairs at 888-894-9150. Do not return to the place of purchase.

Before assembling your chair, watch an assembly video at: [www.sharperimagemassagechairs.com/assembly-tutorials](http://www.sharperimagemassagechairs.com/assembly-tutorials)

Alternatively, scan the QR code to go directly to the URL above.



SCAN CODE

**STEP 2:** Open the box by lifting the top upwards. Remove packaging materials and protective covering from the chair. Remove the Metal Clip from the Base rod pin. Slide out the Base rod pin from the base rod. Place the Base rod pin, Metal clip, and plastic spacers to the side.

**STEP 3:** Lower the footrest towards the ground and align the base rod on the underside of the footrest to the connecting rod on the chair body. Place one plastic spacer on each side, with the narrow end facing inwards. Slide the base rod pin in through both the base rod and the connecting rod, then insert the metal clip onto the end of the pin.

**STEP 4:** From inside the installation bag, grab the Small Cover Plate, Large Cover Plate, and two Screws. Locate the vent tube housing underneath the footrest. Place the Vent Tube Sleeve between the two Screw Columns. Cover with the Small Cover Plate and secure to the chair with Screws. Insert the Large Cover Plate over the Small Cover Plate.

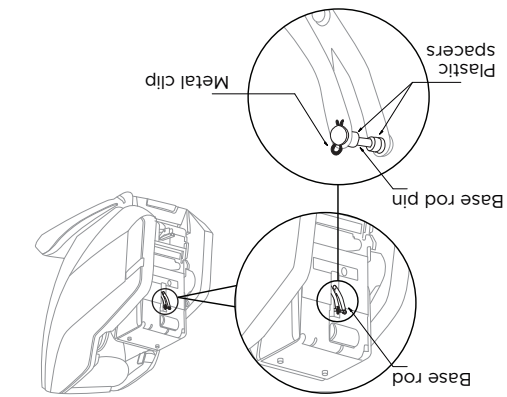
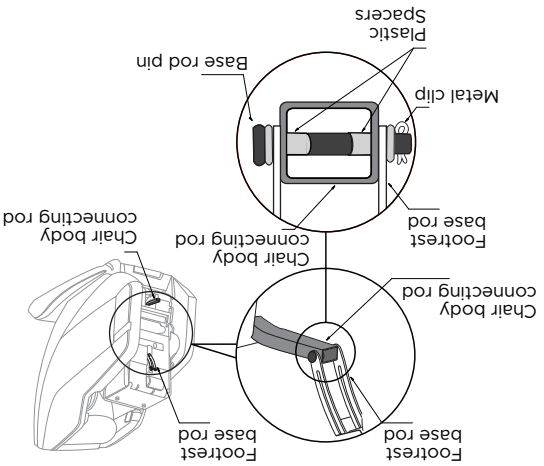
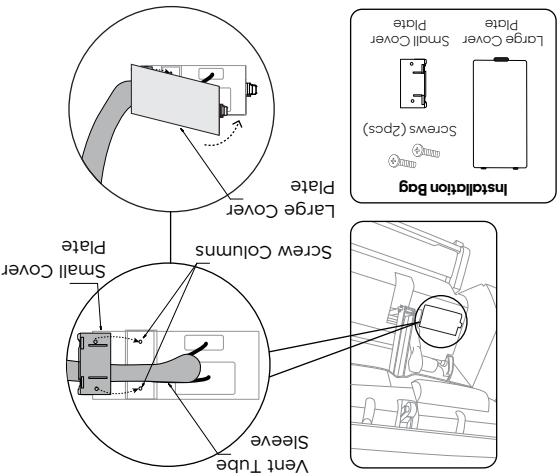

**Final Check:**



Power on the remote and select a program to start a session.



Review chair for smooth operation. If things are not operating correctly, review all assembly steps. Call Sharper Image Massage Chairs' support at 888-894-9150 if you need live US-based support.

If you wish to use an APP to control the chair, download from the Apple or Google app store and follow pairing instruction found within the APP.

**You are done; time for a Massage!**



SCAN CODE

Register your product at [www.sharperimagemassagechairs.com/warranty/registration](http://www.sharperimagemassagechairs.com/warranty/registration) to ensure it is in our system. This will simplify the warranty process should you ever need it.

Alternatively, scan the QR code to go directly to the URL above.

**SHARPER IMAGE®**  
MESSAGE CHAIRS

72 Stard Road, Seabrook, NH 03874  
Toll Free #: 888-894-9150 | [www.sharperimagemassagechairs.com](http://www.sharperimagemassagechairs.com)

Version 1.3

SHARPER IMAGE

**RELIEVE 3D  
MESSAGE CHAIR**

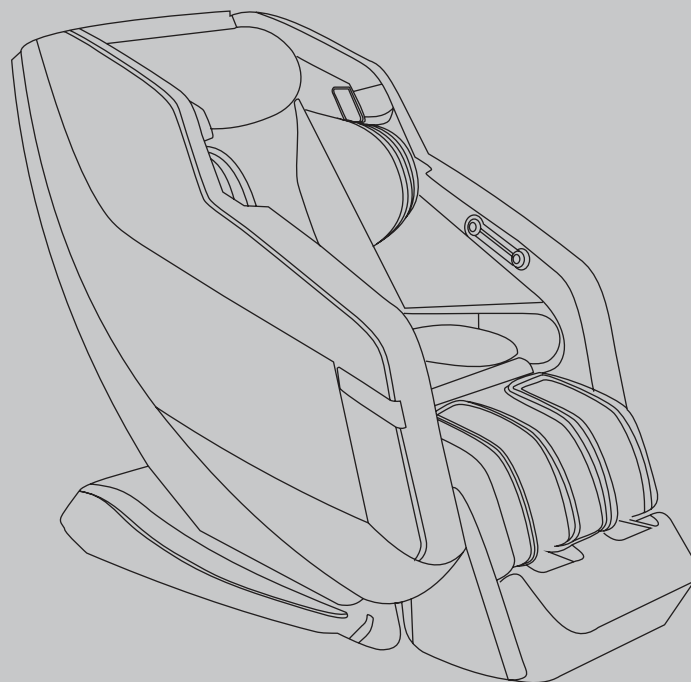

ASSEMBLY GUIDE

# SHARPER IMAGE®

## MASSAGE CHAIRS

**5 STEP 5:** Cut the panels on the back wall of the cardboard tray. This will create a runway to wheel your chair out onto the floor. **It's always recommended two people move the chair.** Using your foot as a support, lean the chair backwards towards you to tip it up onto the wheels built into the base. Make sure not to tip the chair too far back.

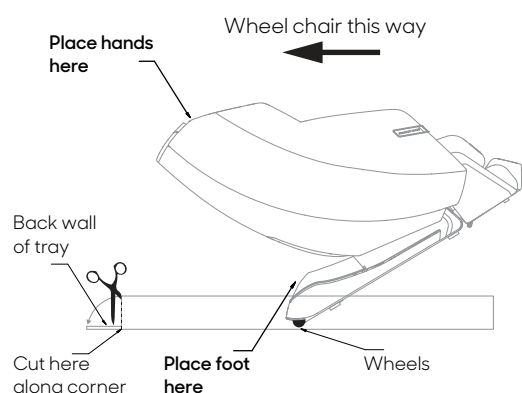

**6 STEP 6:** Connect the chair's power cord to a grounded 110V electrical outlet and plug it into the respective port on the back side of the base of the chair. Flip the main power switch on.

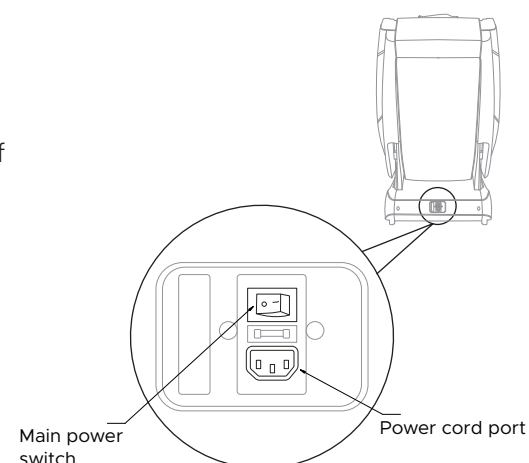

**7 STEP 7:** Your remote control should come already attached to the chair body. Remove the plastic wrapping from the remote control. To store the remote control in the chair, place it on to the magnetic remote holder located on the inside of the arm panel above the arm rest.

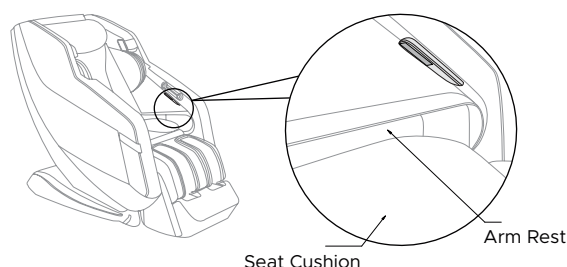

**8 STEP 8:** The arm rest of your chair comes with a unique feature: swing the arm rest up to reveal an arm massage sleeve. Once you are done, swing the arm rest back down to use it again as an arm rest.

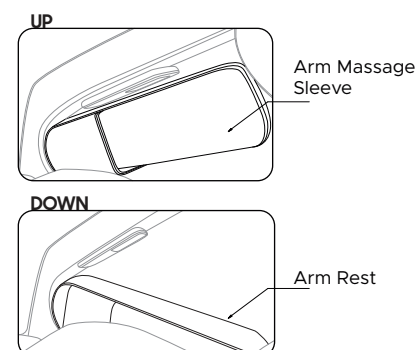

**If you plan to move your chair through a doorway that is less than 32" wide, you must first take off the arm panel/s. See below.**

**9 STEP 9:** Remove the top of the back cushion from the chair body by undoing the zippers on both sides and the top. Detach the lower half of the back cushion by removing from the velcro under the seat cushion.

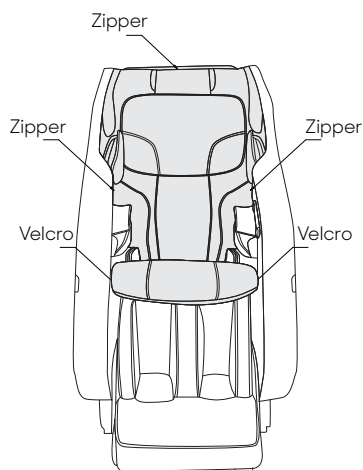

**10 STEP 10:** Using the screwdriver provided, remove the screws from the metal plate located on the inside of the left arm panel.

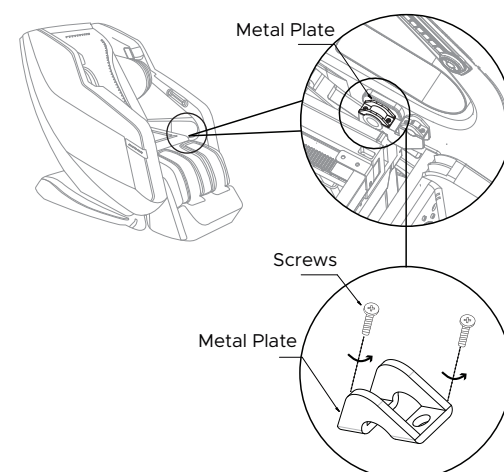

**11 STEP 11:** On the inside of the arm panel locate the L-Shaped air hose and the electrical wires. Pull out the L-Shaped air hose and unplug the electrical wires.

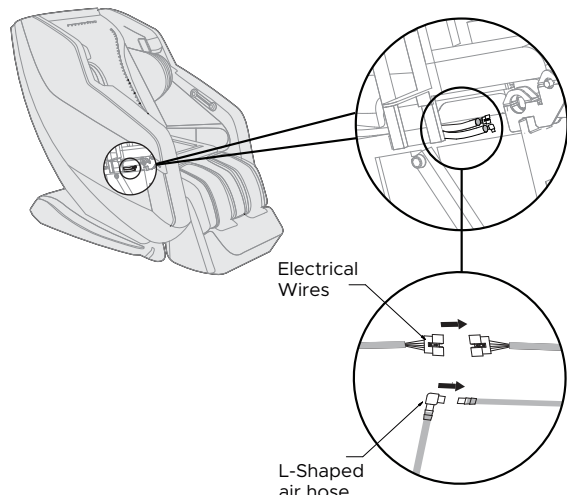

**12 STEP 12:** To remove the arm panel from the chair body, lift up the arm panel until you have removed it from the three docking sites on the chair body.

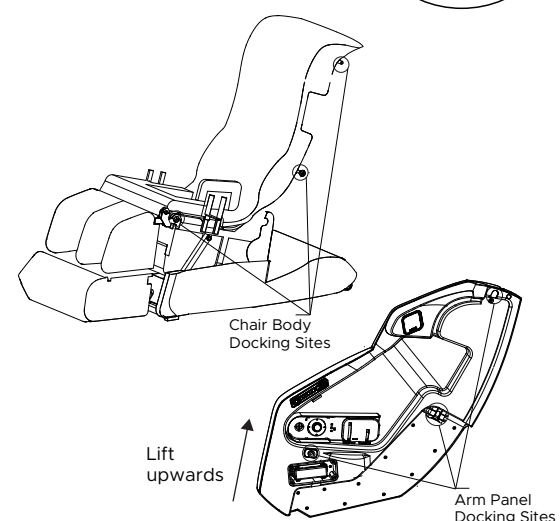

## To re-attach the arm panels...

**13 STEP 13:** Align and connect the three chair body docking sites with the docking sites on the inside of the arm panel (**location of docking sites shown in step 12**). On the inside of the arm panel, locate and connect the L-Shaped air hoses and plug the electrical wires together (**location of L-shaped air hoses and electrical wires shown in step 11**)

**14 STEP 14:** Using the screwdriver provided, on the inside of the left arm panel, re-attach the metal plate and screws from **step 10**. Attach the back cushion to the chair body by fixing it to the velcro underneath the seat cushion, and zipper it to the top and sides of the chair body (**location of velcro and zippers shown in step 9**)