

Deluxe 3D Massage Chair

RT8760
USER MANUAL

Thank you for your purchase of this product. Before using, please read this USER MANUAL carefully, and pay special attention to the safety precaution to ensure proper operation and use.

Please keep this USER MANUAL properly for further reference.

▶ CONTENTS

SAFETY PRECAUTIONS	1
NAME AND FUNCTION OF EACH COMPONENT	3
External structure	3
Internal structure	3
Controller	4
Instruction of Controller	5
Instruction of display screen menu	6
FUNCTIONS AND FEATURES	12
CONTROL VIA BLUE TOOTH	13
PREPARATION BEFORE USING	14
Installation Method	14
Installation position	18
Floor protection	18
Surrounding environment	18
Grounding	18
Move method	19
Turn on power supply	19
Massage chair commissioning	20
Before sitting in the chair	20
Legrest Extend and Retract	21
After using	21
PRODUCT STORAGE AND MAINTENANCE	22
TROUBLE SHOOTING	23
TECHNICAL SPECIFICATIONS	24

▶ TECHNICAL SPECIFICATIONS

Name: Deluxe 3D Massage Chair

Model: RT8760

Rated voltage: 220-240V~

Rated frequency: 50/60Hz

Rated power: 180W

Safety design: Class I

▶ TROUBLE SHOOTING

No.	Problem	Possible Cause	Solution
1	The sound “Xu Xu”, “Ta Ta” is heard.	It is a normal sound made by the working motor or the sound is produced when the massage ball is rubbed against the cloth cover.	It is normal and no need for treatment.
2	The machine can not be started up.	The power supply plug is detached.	Insert the power supply plug into the socket again.
		The power supply switch is not turned on.	Turn on the switch
		The fuse of massage chair blew out.	Replace a new one with the same mode
3	The airbag installed at seat cushion or legrest can not work.	To check whether there is air tube blockage.	To clear the air tube





If abnormal phenomenon still remains after above measures have been taken to the massage chair, please contact local distributor for repair and maintenance.

Note: Do not dismantle the product by yourself, and our company shall shoulder no responsibility to the damage of the product or the injury of people caused by improper use! Thanks your cooperation.



▶ SAFETY PRECAUTIONS

Safety Precautions

- ▶ Before using, please read this “SAFETY PRECAUTIONS” carefully to ensure proper operation.
- ▶ The following “SAFETY PRECAUTIONS” is of great help to your correctly use of this massage chair.
- ▶ To clearly indicate the degrees of danger and damage, the classes of accidents caused by incorrect use are classified into “WARNING” and “CAUTION”, instructions marked as followings should be strictly followed:



 WARNING	Improper operation may cause injury to users.
 CAUTION	Improper operation may cause users injury or product damage.
	Forbidden. Specific instruction will be indicated in the diagram drawings.(E.g, the left drawings means disassembly is not allowed.)
	Compulsory Specific instruction will be indicated in the diagram drawings.(e.g, the left drawings means to disconnect the power plug)

WARNING

 COMPULSARY	<p>We recommend that those with any of the following conditions should consult a doctor before using.</p> <ol style="list-style-type: none"> 1. Those who are using electronic medical instrument imbedded in the body, such as cardiac pacemaker etc. 2. Those that are being treated by doctors, especially those who feel uncomfortable. 3. Those who are malignant tumor patients, heart disease patients, acute patients. 4. Women who are pregnant or menstruating. 5. Those with osteoporosis or fracture spine. 6. Those with skin disease or those whose skins are injured. 7. Those whose body temperature is over 38 degrees (Febrile Phase).
 PROHIBITED	Do not allow the mentally disabled to use the chair alone. (It is OK under supervision)
	Do not allow children play on massage chair.
	Do not allow more than one person to use this massage chair at a time.
	If the power cord or power plug becomes damaged in any way you must disconnect from the mains supply immediately and consult an authorized service engineer for repair or replacement.
	Do not damage, process, excessively bend, pull hard, twist or knot power cord.
 NO DISASSEMBLY	Juveniles are not allowed to use this product.
	Anyone else, except maintenance personnel specified by our company, should not disassemble, maintain, or remodel this massage chair. If any problem, please contact local dealer immediately.

SAFETY PRECAUTIONS

CAUTION

 COMPULSARY	<ul style="list-style-type: none"> ◆ Please do not continuously use the massage chair over 20 minutes, and it is limited to massage a particular part of body in 5 minutes. ◆ Please put the massage chair on flat ground for use. ◆ When adjusting the legrest or backrest, please do not exert excessive force on it; in addition, keep children and pets well clear. ◆ When removing power plug, please hold the insulation plug, do not pull power cord. ◆ Please do not use the power supply that is beyond the specified electric voltage, as this may cause fire disaster or damage massage chair. ◆ Before using, please uncover the back cushion to check whether backrest or fabric is damaged; if damaged, please stop using this massage chair immediately, and contact franchiser for repair immediately. Please do not operate the controller with damp hands, and do not put heavy objects on controller. ◆ Only people less than 120kgs are acceptable. ◆ Please do not use other therapeutic equipments together with this massage chair. ◆ During use, if you feel uncomfortable, please stop use immediately and consult your doctor. ◆ This massage chair is designed and intended for non commercial household use only, do not use the massage chair for medical treatment. ◆ The massage chair is equipped with heating function, so people who are insensitive to heat must use it carefully. ◆ Always switch off power and remove the plug from the mains socket immediately after use and before cleaning. ◆ To avoid causing discomfort, do not use the massage chair immediately after meals.
 PROHIBITED	<ul style="list-style-type: none"> ◆ In case that PU cover, like back cushion or cloth cover is broken, please stop using the chair at once, and contact the distributor or repair man for help. ◆ Do not fall into sleep on massage chair, when the massage chair is working. ◆ Do not use the massage chair when you are drunk or feel bad. ◆ If the upholstery becomes dirty, please use only known good quality leather cleaner, do not use chemical cleaners, petrol or detergents etc, and do not spray pesticide on it. ◆ Do not sit on backrest, legrest, or armrest to avoid accidental injury or machine fault. ◆ Please do not smoke while using the massage chair.
 REMOVE PLUG	<ul style="list-style-type: none"> ◆ Before maintenance, please pull out power plug. In addition, please do not insert or unplug the power plug with damp hands, to avoid electric shock. ◆ When the massage chair is not in use, please switch off power and remove the plug from socket. When power is off, please cut off power supply immediately and pull out the power plug from socket.

PRODUCT STORAGE AND MAINTENANCE

Maintenance

- ▶ Please twist the cotton cloth which has been dipped in neutral detergent before wiping the back cover, hand rest, legrest, air tube and some other plastic components, then use a dry cotton cloth to wipe them again.
- ▶ Use dry cloth to wipe the controller, DVD, and power supply box.
- ▶ Use a piece of cloth that has been dipped with neutral detergent to wipe the back cushion and pillow, then use a piece of wet cloth to wipe them, and finally put them to a well-ventilated place for natural drying.

Caution

- ▶ Make sure to pull out the power supply plug firstly before maintenance. Do not use wet hands to pull out the plug to avoid electric shock. When clean the back cover, please be cautious of detergent entering into the power supply box!
- ▶ Do not iron the upholstery.

Storage method

- ▶ Wipe off dust and dirt from the product after use, if the product is not to be used for a long period of time, please cover the product with a dust cover (self provided).

Caution

- ▶ Do not store the product under direct sunlight or in places of high temperature. This may cause the color of the upholstery to fade.

Kind reminding

During daily use, please check whether the following symptoms exist:



- ▶ Scorched smell exists.
- ▶ When touch the wire, the power is on, but sometimes off.
- ▶ The power supply cord is hot.
- ▶ Other abnormal symptom

Caution

- ▶ Please stop using the massage chair to avoid breakdowns and accidents occurring if any above symptom exists.
- ▶ Turn off the power supply switch and pull out the power supply plug, and then contact the local distributors or headquarters for repair and maintenance.
- ▶ Except all the normal operation and maintenance mentioned above, any other repair and maintenance can only be operated by our authorized dealer or service agent.

PREPARATION BEFORE USING

Legrest Extend and Retract

- ▶ Under the possible slope of legrest, press  or  to adjust the relative position of leg and legrest manually when legrest is static in order to get the best massage.

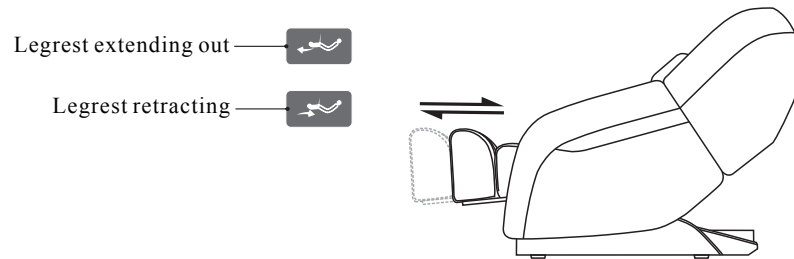

- ▶ Legrest can be extended or retracted automatically or manually according to different position and height, because of sensor inside

WARNING

- ▶ Do not play in the chair and conduct improper operation.
- ▶ Before adjusting the angle between calf and backrest parts you need to make sure no obstacles is around.
- ▶ Do not insert leg, foot or other goods into chair's clearance when leg parts extend or reset.
- ▶ Do not get down from the chair when the chair is in the reset state.

After using

- ▶ Please power off the chair and unplug the chair power cable from the power supply socket after using well the massage chair.
- ▶ Put well the controller inside of the pocket.
- ▶ Please power off the chair and unplug the chair from the power supply socket when the chair is not in use, to avoid children to start the chair accidentally.
- ▶ Please store well the chair if it is not in use for a long time.

NAME AND FUNCTION OF EACH COMPONENT

External structure

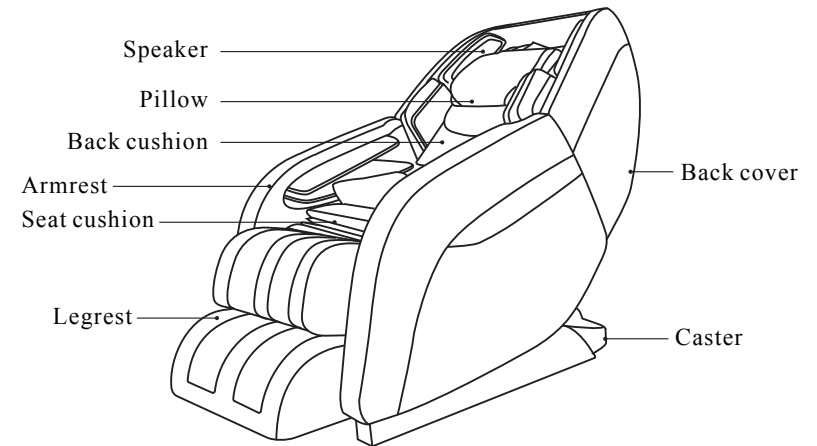

Internal structure

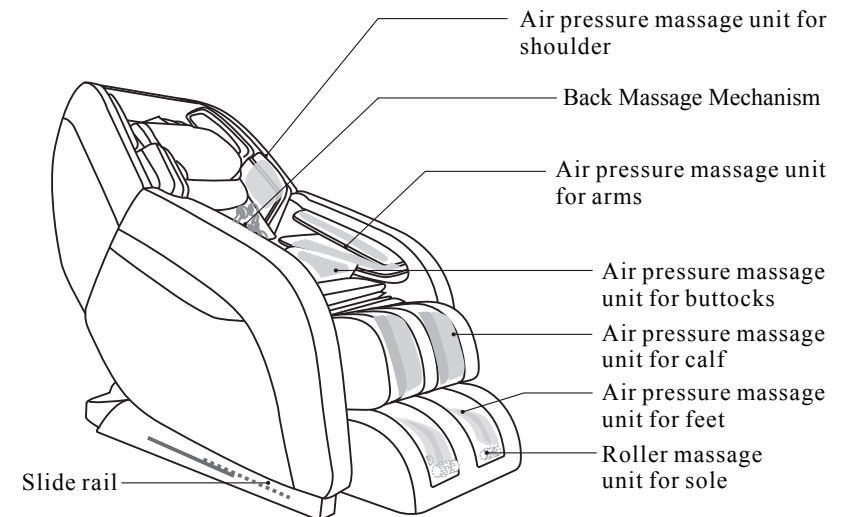

▶ NAME AND FUNCTION OF EACH COMPONENT

Controller

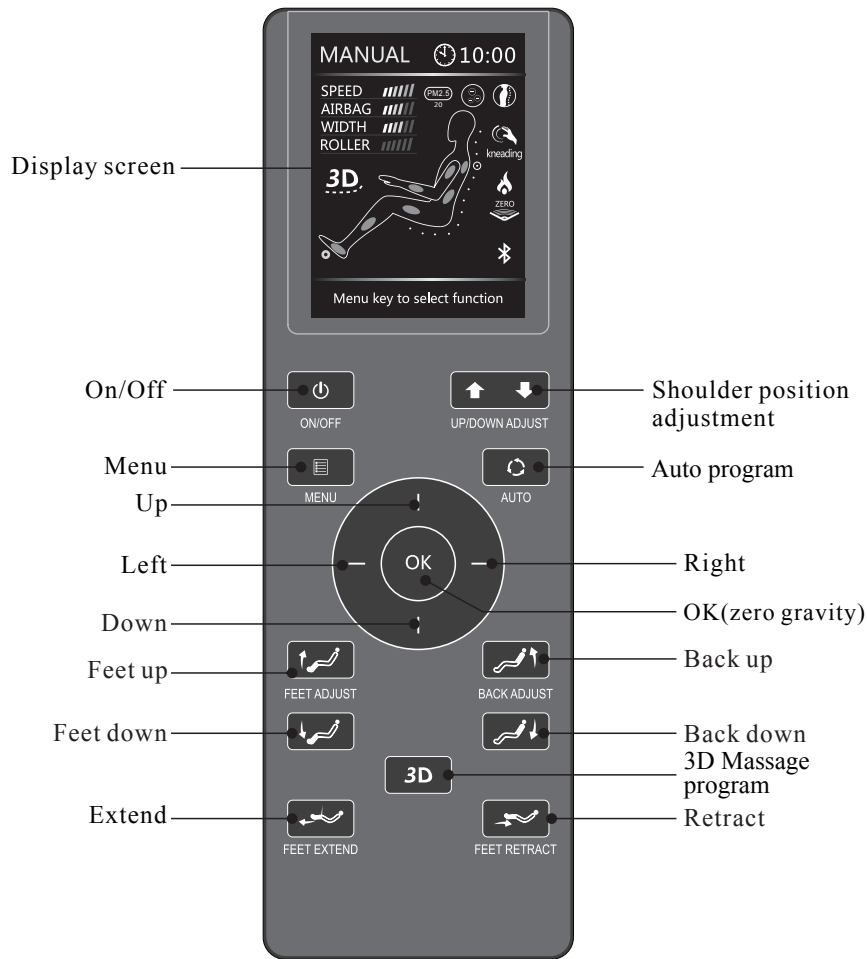

▶ PREPARATION BEFORE USING

Massage chair commissioning

- ▶ Before commissioning, please make sure there is enough space around the chair. Then use the controller to recline down the chair backrest to the limit position, rise up the legrest to the highest position and stretch out to the limit length.
- ▶ Testing all functions work normally, then power off the chair, return back to original position.
(How to select the program, please refer to “ Controller instruction” and “display screen menu instruction”)

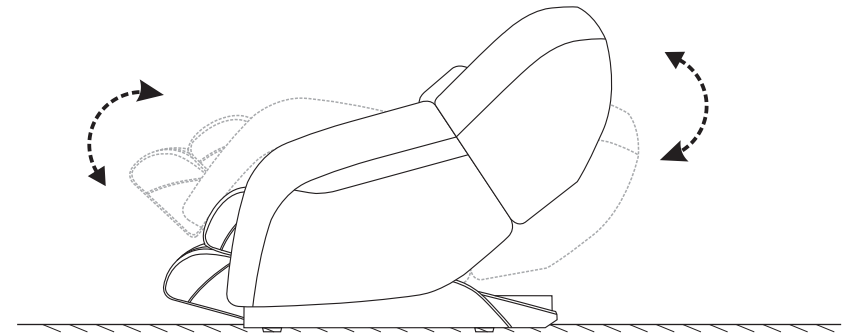

Before sitting in the chair

- ▶ Make sure the legrest is well installed.
- ▶ Make sure the chair is in original position, if any part is not in initial position, please power on/off again to make the whole chair go back to original position.

⚠ Caution

- ▶ If the legrest rises up, please do not seat on the chair.
- ▶ Do not make the legrest to suffer from heavy loading suddenly, or it may damage the legrest mechanism.

PREPARATION BEFORE USING

Move method

- ▶ There are moving rollers at the bottom of the chair.
- ▶ Raise the back to the highest point.
- ▶ Switch off and plug out the chair.
- ▶ Lift the front part of the chair as showed in the figure(one person raise the front part via holding moving holder, another person push the chair when holding the top of the chair) , move the chair by the rollers.

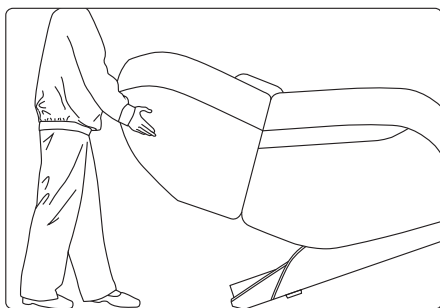

⚠ Caution

- ▶ Don't move it when there is people in it.
- ▶ Don't use the armrest while moving the chair, only hold the moving holder in the back and front

Turn on power supply

- ▶ Plug the power cord into three core socket with well grounding.
- ▶ Power on the chair by pressing the button at the lower part of the exterior of the right armrest .

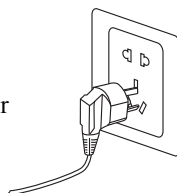



⚠ Caution

- ▶ Before switching on the chair, please make sure there is no damage on the power wire and other exposed wires.
- ▶ Make sure the power switch is off before the chair is connected to electricity.

NAME AND FUNCTION OF EACH COMPONENT

Instruction of Controller

-  **On/Off**
 - ▶ When power is on, click this button, display screen is lightening, then click up/down button to choose the auto mode, manual mode, 3D massage, air pressure massage, heat and set menu.
 - ▶ Click this button again to turn off all functions. The default working time is 20 minutes

-  **Menu**
 - ▶ Click this button to choose auto mode, manual mode, 3D massage, air pressure massage, heat and set menu.

-  **Shoulder position adjustment**(mechanism up and down adjustment)
 - ▶ Under manual point mode, press the up or down keyboard to place the exact massage point.
 - ▶ Under auto mode body sensor, press this keyboard to micro adjust shoulder place.

-  **Auto programs**
 - ▶ When massage chair is working, press auto button to enter auto program menu, you can choose sports refresh, extention, rest&sleep, working relief, neck&shoulder, waist&spine, boss nursing, queen slimming or soul spa.(3D massage excluded). (See the LCD menu for detail)

-  **Direction adjustment**
 - ▶ Under menu and auto mode, press the button to adjust direction. When program is determined, press the middle OK button to confirm it and enjoy the chosen massage.
 - ▶ During the massage, press OK button to switch over zero gravity. Press up or down button to adjust mechanism speed. Press left or right button to adjust airbag force.

-  **3D massage**
 - ▶ Under manual mode, press 3D button to adjust the 3D force.

-  **Feet up**
 - ▶ Press this button, the legrest will be moved up to the top position, releasing this button, it will stop.

-  **Feet down**
 - ▶ Press this button, the legrest will move down to the lowest position, releasing this button, it will stop.

▶ NAME AND FUNCTION OF EACH COMPONENT



Back up

▶ Press this button, the backrest will be moved up to the original position, release this button, it will stop.



Back down

▶ Press this button, the Backrest will be moved down to the lowest position, release this button, it will stop.



Legrest extend

▶ Press this button, the legrest will be extended to the longest position, releasing this button, it will stop.



Legrest retract

▶ Press this button, the legrest will be retracted to the original position, releasing this button, it will stop.



WARNING

▶ Press power button after use it to make the chair in reset state. Please press any buttons in the remote controller to stop reset. Press the power button again to continue the operation or enter into massage state.

Instruction of Display screen menu

▶ Auto mode

When electricity is connected, press power button, LCD is on. Press auto to enter auto program menu, you can choose sports refresh, extention, rest&sleep, working relief, neck&shoulder, waist&spine, boss nursing, queen slimming or soul spa. (See the menu picture below)

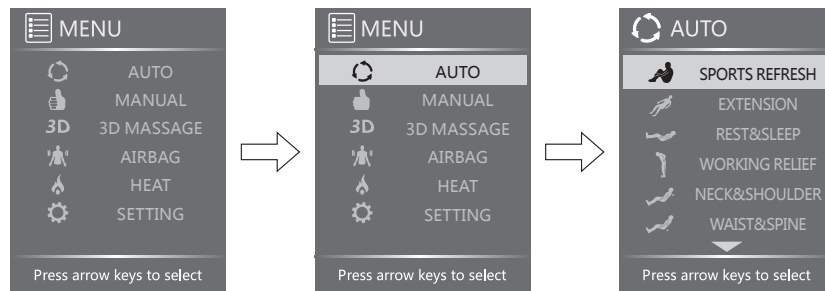

Sports refresh: This is designed for the muscles after sports activities and exercise. It can ease and relax muscles after intense exercise, especially promote the body circulation system to improve the muscle recovery after exercise.

Extention: This massage comes from Thai massage. the strong kneading and stretch of the body can effectively stretch legs, waist and other parts, and it is the best choice to relax tired muscles and increase physical vigor.

▶ PREPARATION BEFORE USING

Installation position

Safety distance for the periphery of massage chair.

- ▶ Please make sure there is adequate space for installation this product:
Back: minimum 10cm from the wall or any other blocks;
Front: minimum 60cm from any blocks;
- ▶ In order to prevent from signal interference, please keep at least 1m away from the TV, radio and other video and audio devices.

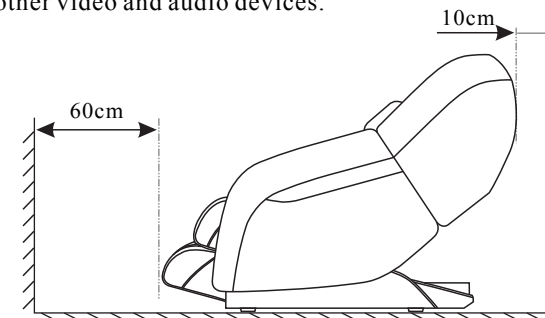

Floor protection

- ▶ Please put carpet or other pad under the massage chair, in order to avoid any unpredictable impression on the floor.

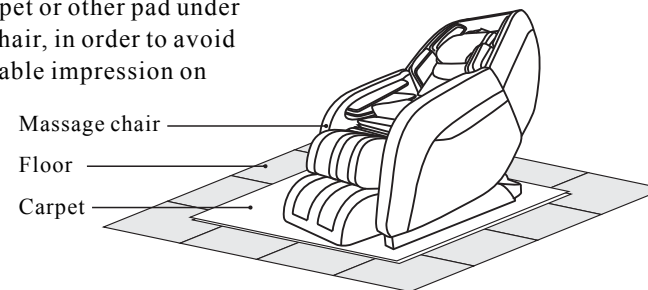

Surrounding environment



Keep the massage chair away from damp places (such as bathroom) to avoid it is affected with damp and electric leakage.



Keep the massage chair away from high temperature sources in case of causing fire accident or damage to the cortex.

Grounding

This massage chair belongs to Level One electrical appliance, make sure to use three-core power supply socket and to guarantee the ground wire connected to the power supply socket has obtained good ground connection to avoid electric leakage, electric shock and some other negative effect during use.

PREPARATION BEFORE USING

Step 5 Installation of controller unit

- ▶ Connect the data line of the controller to the port on the inner side of right armrest(pay attention to the convex-concave between connector and port); then fix the screw cap. (see the figure below)

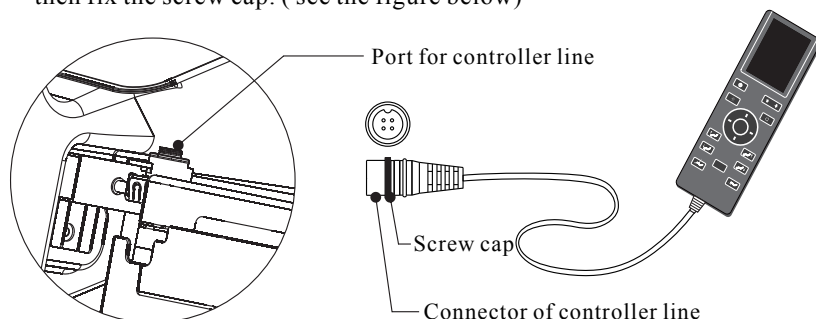

Step 6 Other Accessories

- ▶ Connect the power wire connector to the port on the outer side of right armrest;
- ▶ Switch on the chair, and use the controller to raise the backframe to normal position.

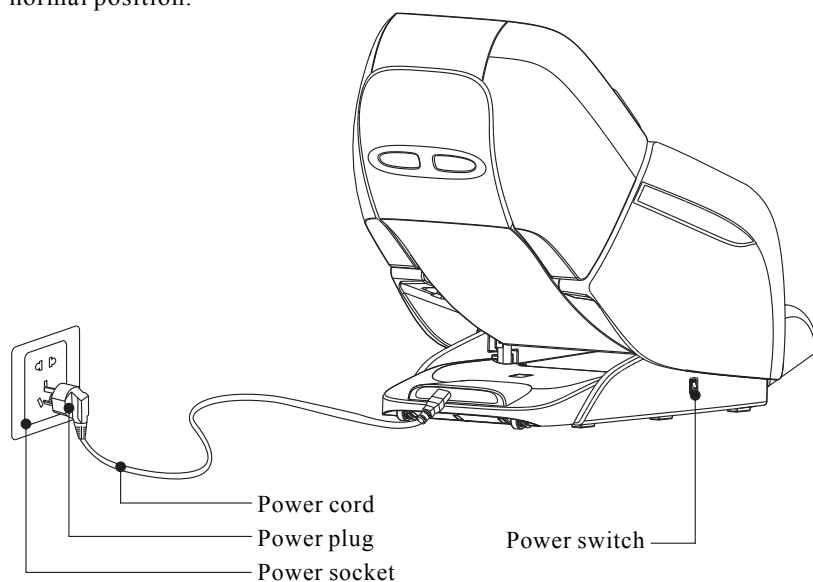

NAME AND FUNCTION OF EACH COMPONENT

Rest and sleep: To improve the quality of lunch break and sleep; The mild massage kneads body parts from heavy strength to light one, from light to no strength to relieve tired body gradually.

Working relief: This is an exclusive program for white collars, who work long time at desk and often make business trip, it can ease muscles and recuperate body.

Neck and Shoulder: To relieve neck and shoulder pain symptom. 80% of the massage time will focus on the neck and shoulder. The curve design of the chair backrest makes the massage rollers completely touch the shoulder and neck. So it can effectively relieve your fatigue of these parts.

Waist and Spine: To relieve the pain of lumbar vertebra. 80% of the massage time will focus on the lumbar vertebra and the rollers will conduct specific massage to relieve the sense of tension and keep the health of this part.

Upper Back: Massage intensity is heavier; Massage area mainly focus on shoulder and neck. This mode is designed for office staffs who work at desk habitually, and this mode is aiming at relieving muscle pain of shoulder and neck.

Lower Back: Massage intensity is gentler; Massage area mainly focus on the waist and back. This mode is designed for woman who want to keep slim, and is beneficial to promote metabolism.

Soul spa: This mode is suitable for short leisure massage at morning or noon in order to help invigorating muscle.

Gentle Care: Mild & gentle massage, mainly focus on Neck&shoulder, Waist&back and Sole to relieve fatigue. The main massage techniques are kneading, rolling, scraping and tapping.

Air Soothing: By specific speed changing massages shoulder & back. To avoid sensitive acupoints, back rollers move up&down more frequently to relax muscle.

▶ Manual Programs:

- Press Menu button, choose Manual and press it to enter manual programs.
- Press up or down button to choose mode, part, width, speed, roller or zero.

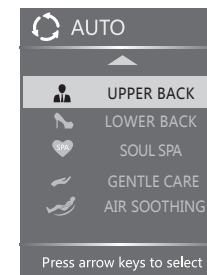

▶ NAME AND FUNCTION OF EACH COMPONENT

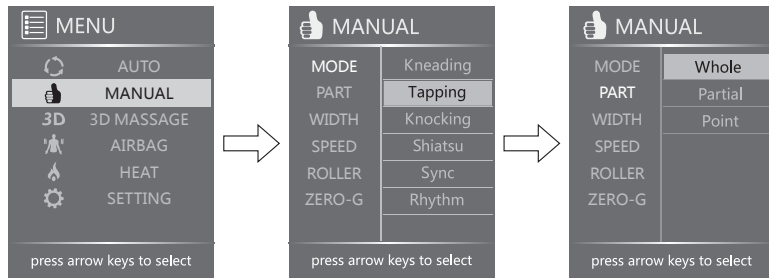

Mode: Under mode function, press right button first, then press up or down button to circulation choose massage manipulation of kneading, tapping, knocking, shiatsu, sync, or rhythm.

Part: Under Part function, press right button first, then press up or down button to circulation choose whole, partial or point. Back massage mechanism is by whole, partial and point

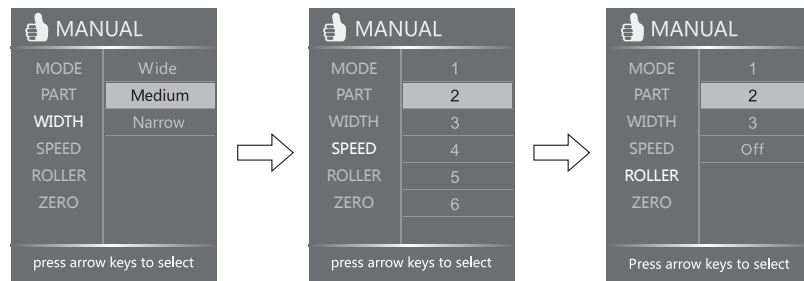

WIDTH: Under Width function, press right button first, then press up or down button to circulation choose Wide, Medium or Narrow.

SPEED: Under SPEED function, press right button first, then press up or down button to circularly choose speed from one to six.

ROLLER: Press MENU button first, then choose ROLLER, adjust the roller speed from 1 to 3 or stop the rollers by pressing up or down button.

ZERO GRAVITY: Zero gravity creates a completely relaxing, naturally comfortable massage position: Somatological design makes back, buttocks and leg stay in a certain angle like lying in space capsule, under which the body pressure is thoroughly released and the muscle come into completely relaxing status.

▶ 3D MASSAGE

Press MENU button first, then choose 3D, adjust the 3D MODE (Deep shiatsu, healthy breath, massage extend), massage force and part.

▶ PREPARATION BEFORE USING

▶ After the calf is well connected with the axis, fasten it by the lock on the left and right side. (see the figure below)

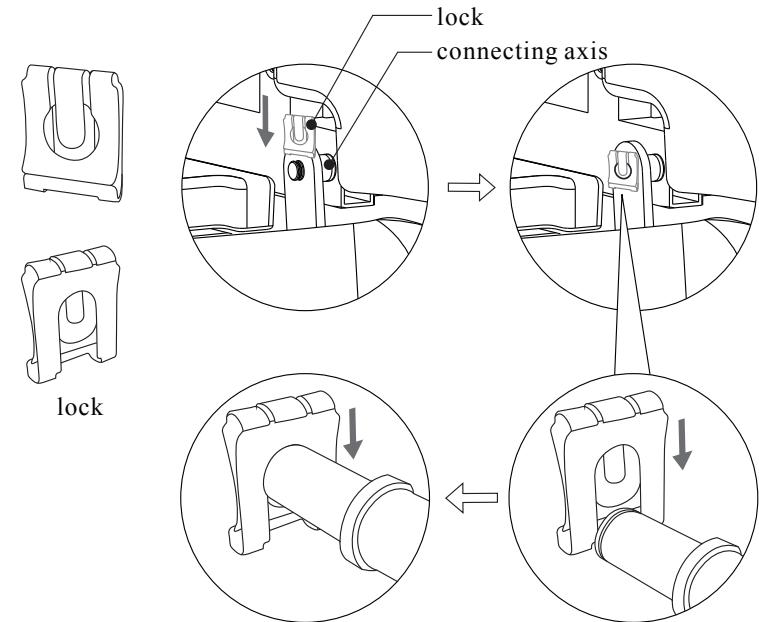

▶ Lift the components of the calf part, push those plugs of calf components (including air tube plug, air vents plug, extension connector) into the corresponding slots on the seat base until it is felt to engage, as illustrated below.

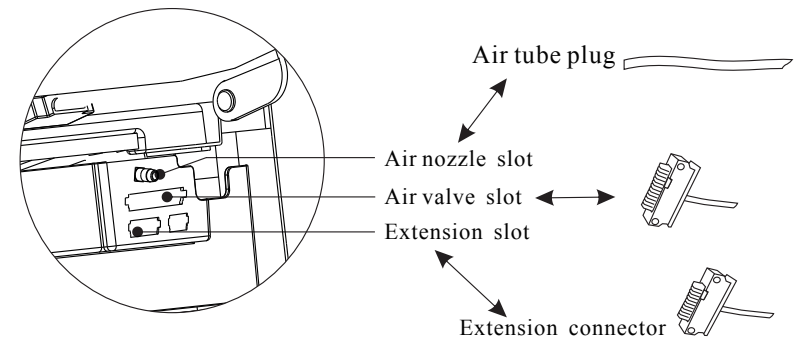

▶ PREPARATION BEFORE USING

Step 3: Installation of chair leg part.

- ▶ Lift the components of calf part, and fit the circle of hook on the coupling shaft, please keep all parts balance when connecting, then so do the another side.

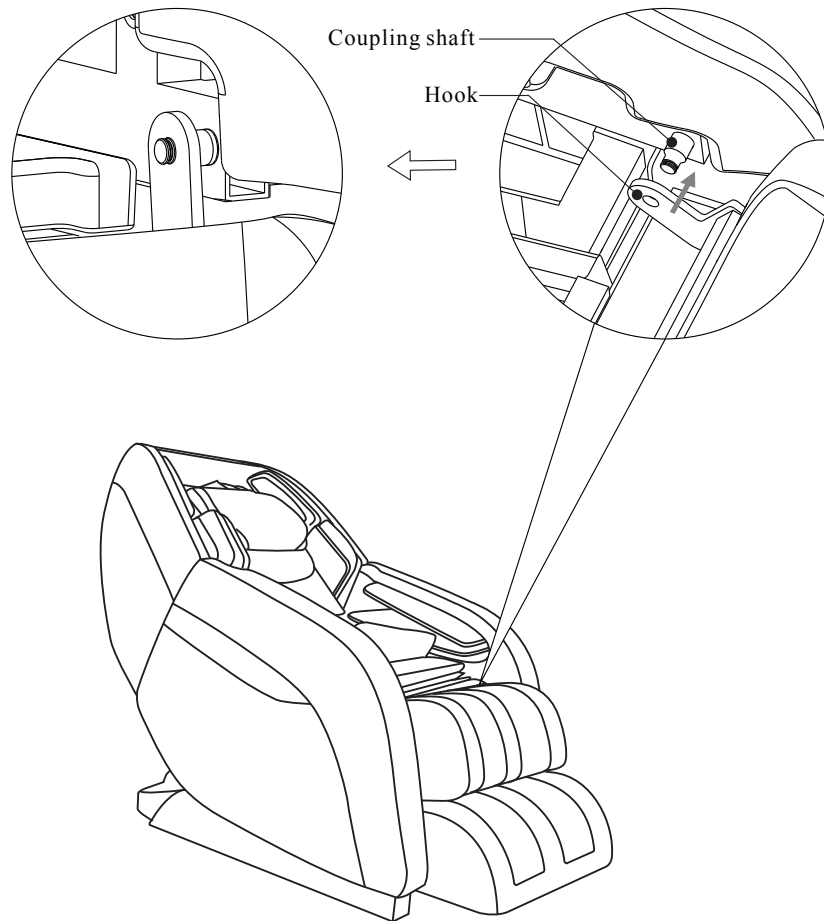

▶ NAME AND FUNCTION OF EACH COMPONENT

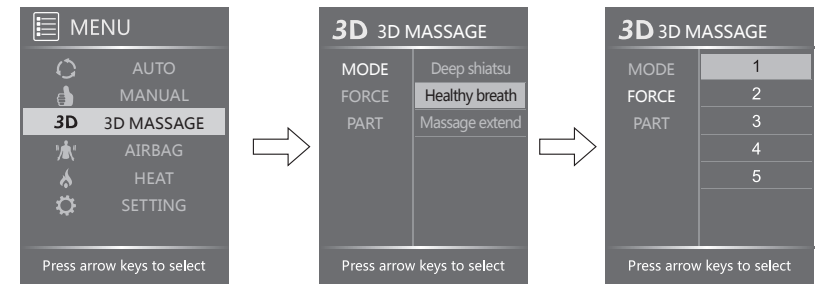

Deep shiatsu: deep shiatsu on the back for 10 minutes;
Healthy breath: 5 minutes breath health works along with chair mechanism's rhythm for breathing in and out, which does good to the user's health.

Message extend: 5 minutes message extend.

FORCE: Under manual, 3D massage force is adjustable from 1 to 5 grades.

Part: Under Part function, press right button first, then press up or down button to circulation choose whole, partial or point. Back massage mechanism is by whole, partial and point.

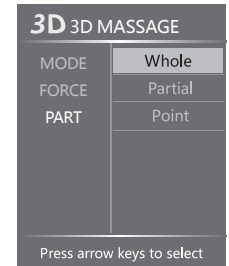

▶ AIRBAG

Press MENU button first, then choose AIRBAG, press up or down button to choose airbag place and force.

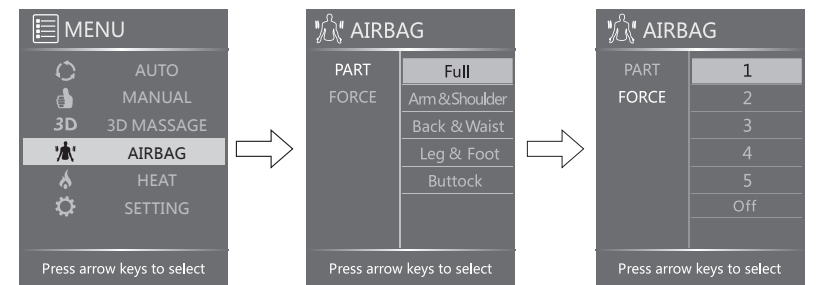

PART:

Under AIRBAG PART function, press right button first, then press up or down button to choose full, arm&shoulder, back&waist, leg&foot, or buttock.

FORCE:

Under AIRBAG FORCE function, press right button first, then press up or down button to choose airbag force from 1 to 5 grades and stop the airbag.

▶ NAME AND FUNCTION OF EACH COMPONENT

▶ Heat

Click “MENU”, choosing “HEAT”, then click right to choose on or off.

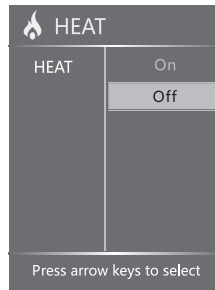
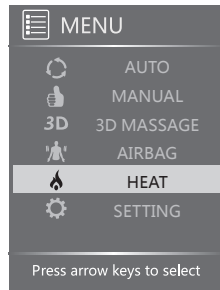

▶ SETTING

Press MENU button, choose SETTING, then press up or down button to set time, language or bluetooth.

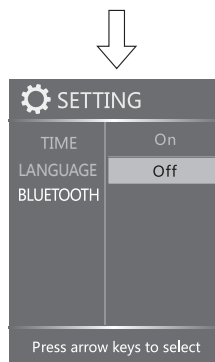
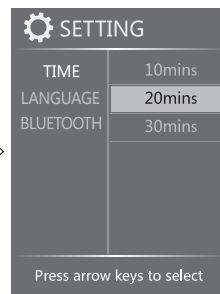
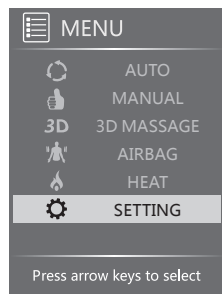

TIME: Under SETTING TIME function, press right button, then press up or down button to choose 10minutes, 20minutes or 30 minutes. The default setting is 20minutes.

LANGUAGE: Under SETTING LANGUAGE function, press right button, then press up or down button to set CHINESE or ENGLISH menu.

BLUETOOTH: Under SETTING BLUETOOTH function, then press up or down button to START or STOP bluetooth.

MEMO: All the above settings are remembered even when the machine is cut off suddenly.

▶ PREPARATION BEFORE USING

Installation method

Step 1: Take out each part of the chair

- ▶ Open the carton, take out all of leather covers of chair and accessories box carefully.
- ▶ Check all the accessories with the list one by one to make sure all accessories are complete.

Step 2: Installation of Armrest

- ▶ Connect the air tube on seat to the air nozzle on the armrest.
- ▶ Hang the rear hook of armrest to the connecting rod of the back rest, and connect the armrest to the side of seat frame, then push it down to the corresponding point. (Figure 1)
- ▶ Fix the front of the armrest with one screw, and the rear of the armrest is fixed with two screws. (Same Installation on the other side.)

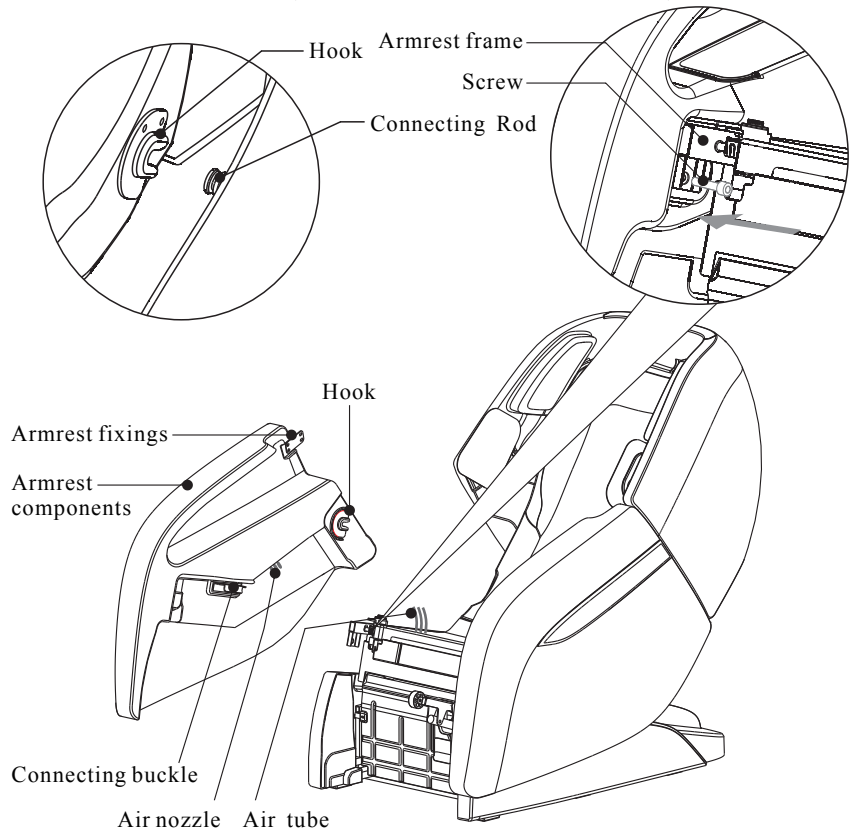

▶ CONTROL VIA BLUE TOOTH

Software

- ▶ Please ask for software from seller, then install on the computer or mobile. (Refer below pics.)

Android System

- ▶ Install well RT8760 touch screen operation software, press setting button of the computer or mobile, press wireless and web set→blue tooth→scan blue tooth device→ RT8760, then match well. When displaying “matching well audio device”, find out RT8760, start the program. Then press setting menu→blue tooth connecting→matched well device→RT8760 for operating the massage chair.

⚠ Caution

- ▶ When matching blue tooth, please make sure the chair is in power on status, otherwise it can't search the chair.
- ▶ If searching I-STAR, but can't match well, please try connecting match.
- ▶ Please pay attention to Android System updating on our homepage.

Equipment requirements

- ▶ Flat PC or other intelligent mobiles which must be with blue tooth function.
- ▶ With high than V4.0 Android System.

▶ NAME AND FUNCTION OF EACH COMPONENT

Note:

1. Under auto mode or manual mode, it will go back to home page as below drawing 10 seconds after without any operating.

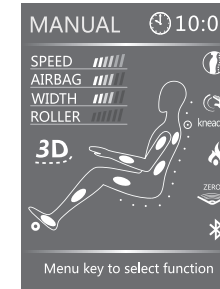

Home page in manual mode



Home page in auto mode

⚠ Caution

- ▶ During working, click “MENU” twice, it will go back to home page immediately.
- ▶ In the home page, under manual mode or auto mode, click the left and right button to adjust air pressure intensity; under manual mode, click up and down, to adjust massage wheels speed.
- ▶ Click “AUTO” to choose auto program directly.

⚠ Caution

- ▶ Please do not disassemble the product to avoid any defective problems.
- ▶ Please do not split water and other liquid into the controller to avoid malfunction of keys and error code.
- ▶ Please do not put heavy things on the controller or power cable.

▶ MEMORY FUNCTION

1: Storing a memory program:

After selecting all of your wanted functions in the manual mode. go to the Auto page and scroll to the bottom of the page. Here you will see Memory one and Memory two. Select either one or two then select “Save”.

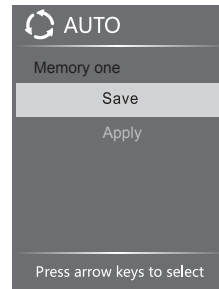
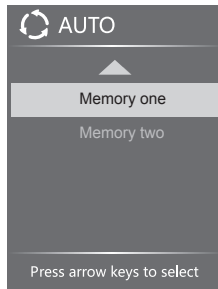

2: Loading a memory program

Go to the Auto page and scroll to the bottom of the page. Select Memory one or Memory two and then select “Apply”. The chair will now apply the program you created in the Manual mode.

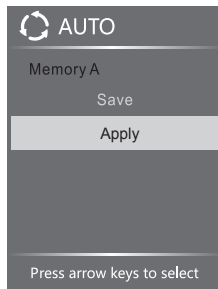

▶ FUNCTIONS AND FEATURES

1: Sliding

Two slide rails at the bottom of chair, after choosing auto or manual program, massage chair will get down and move forward 30cm to save massage using space. further more, it will be good for users to relieve fatigue completely by lying in the chair.

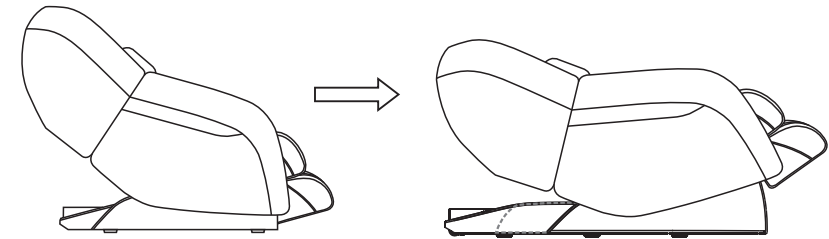

2: ZERO GRAVITY

Zero gravity creates a completely relaxing, naturally comfortable massage position: Somatological design makes back, buttocks and leg stay in a certain angle like lying in space capsule, under which the body pressure is thoroughly released and the muscle will be relaxed completely. Bring users to enjoy the zero gravity.

3: 3D massage mechanism

New design of 3D mechanism and movement perfectly correspond to the somtological principle.

4: AUTO/MANUAL EXTEND LEGREST

Legrest can extend 17cm to match different height auto/manually.

5: AIRBAG MASSAGE

This massage chair has set several airbag at different place (arm, back, waist, shoulder, buttocks, leg and feet)

6: ROLLER MASSAGE FOR SOLE

Three-row rollers massage on feet conduct an all-around shiatsu massage onto the sole.

7: DIVERSIFIED MASSAGE MODES

Diversified massage modes: knocking, tapping, kneading/knocking, kneading, shiatsu and kneading on the leg. which act as a professional massagist.

8: BLUETOOTH AUDIO

Product is designed with bluetooth connection function. It can play music by connecting with Andriod system, iphone, ipad.

9: L-SHAPE SUPER LONG MASSAGE TRACK