

Box 3: Footrest

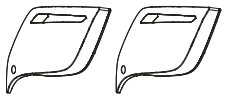

Box 2: Arm Panels (2)



Accessory Box



Shoulder Panels (2)



Chair Body

& Accessory Box

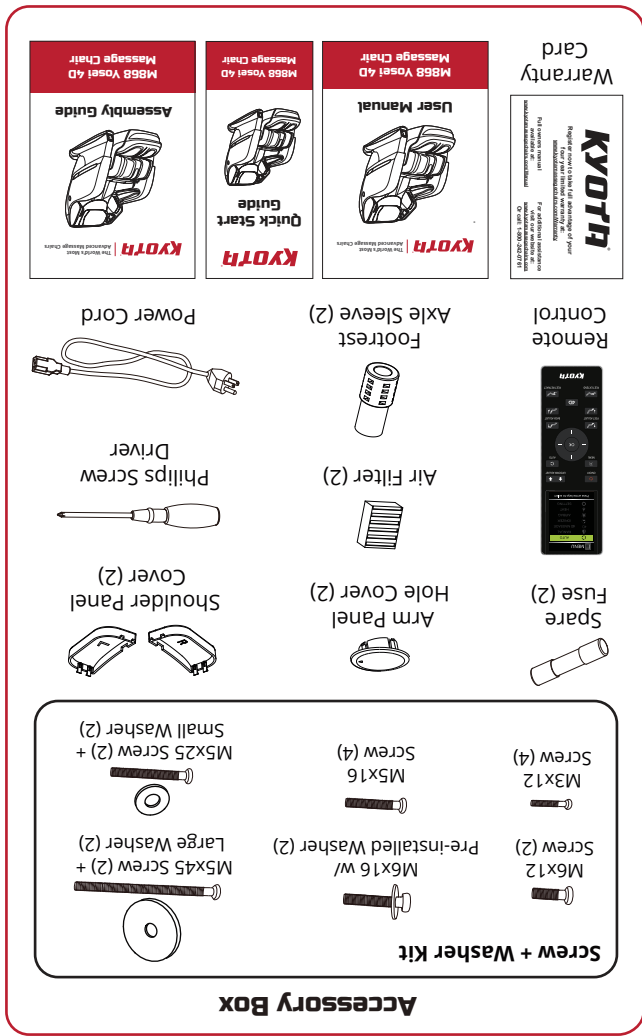

STEP 1: Carefully check box contents to the detail below, making sure all contents are accounted for. If anything is missing, please contact Kyota Massage Chairs at 800 242-0761. Do not return to the place of purchase.



Alternatively, scan the QR code to go directly to the URL above. www.kyotamassagechairs.com/assembly-tutorials

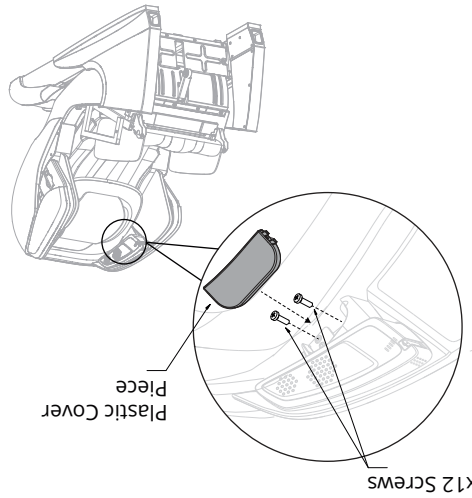

Step 4: To secure the shoulder panel to the chair body, locate the 2 screw holes on the inside of the shoulder panel underneath the speakers and insert two M3x12 screws into the screw holes. Tighten using the screwdriver provided. Finish by inserting the plastic cover piece over the top of the two screw holes.

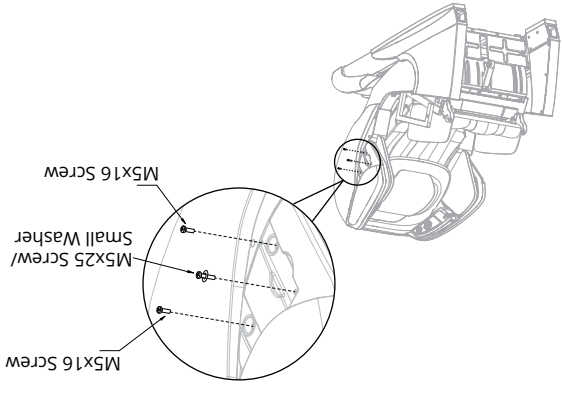

Step 3: Locate the 3 screw holes on the outside of the shoulder panel. Insert the two shorter M5x16 screws and the longer M5x25 screw and small washer into the top hole. Tighten using the screwdriver provided.

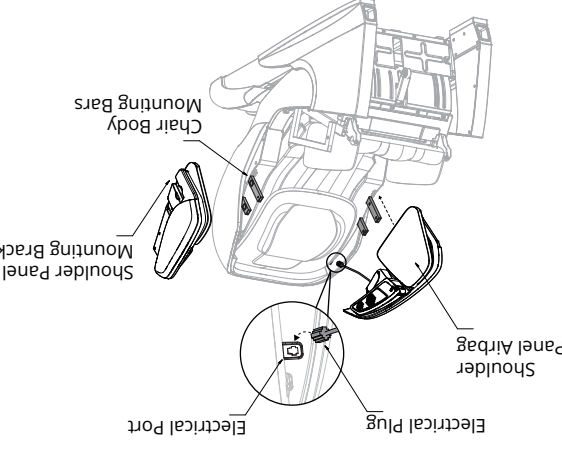

Step 2: Before attaching the shoulder panels, ensure the airbag is toward the front of chair. Connect the electrical plug to the port on the chair body by pushing it in until it clicks. Slide the shoulder panel mounting bracket onto the chair body mounting bars, ensuring that the fabric is out of the way and doesn't get pinched.

Step 15: Lift the axle cover on both footrest hangers. Carefully lift the footrest, placing it in on the footrest hangers; make sure the footrest is centered. To secure the footrest to the chair body, close the axle covers and screw the saved footrest hanger bolts back into the footrest hanger.

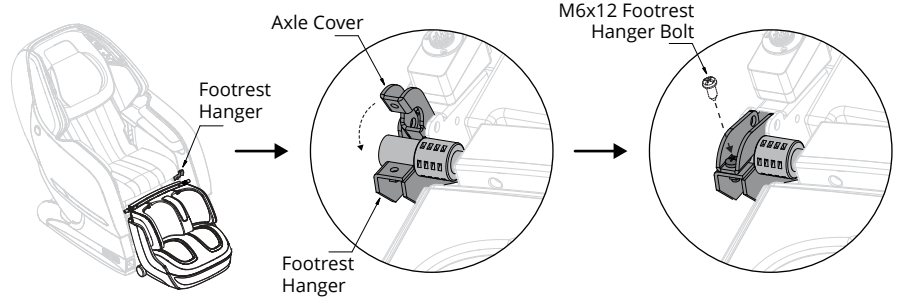

Step 16: Attach the velcro tab on the top of the footrest flap to the velcro tab on the edge of the chair body seat cushion. Zipper the seat cushion and the footrest together as shown.

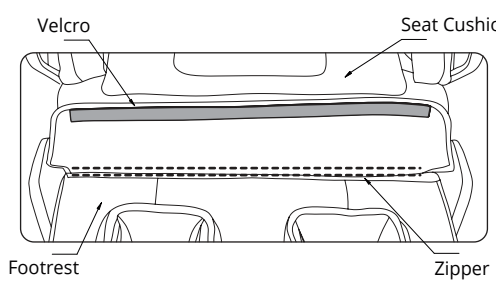

Power on the remote and select AUTO program to start a session. Review chair for smooth operation. If things are not operating correctly, review all assembly steps. Call Kyota support at 800-242-0761 if you need live US-based support. You are done; time for a Massage!



Register your product at www.kyotamassagechairs.com/warranty/registration to ensure it is in our system. This will simplify the warranty process should you ever need it. Alternatively, scan the QR code to go directly to the URL above.

KYOTA The World's Most Advanced Massage Chairs®

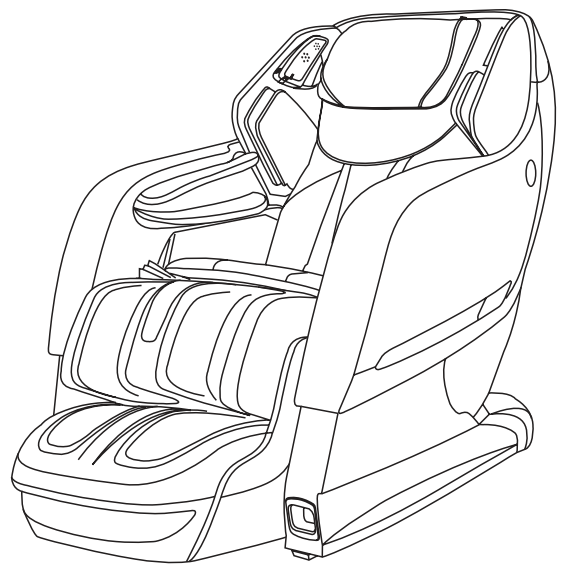

Assembly Guide

M868 Yosei 4D Massage Chair

5 Step 5: Determine left and right arm panels and position them on corresponding side of the chair. Attach the 2 chair body electrical plugs to their respective ports on the arm panel, and connect the air hose to the air hose nozzle.

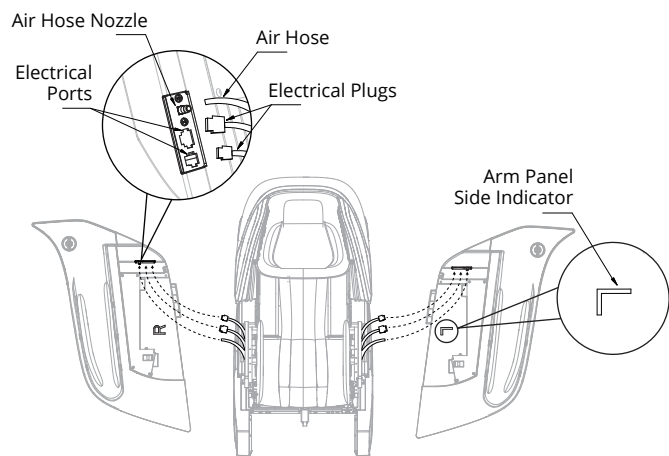

6 Step 6: To attach the arm panel to the chair body, align the groove on the inside of the arm panel with the chair body mounting bracket and push down.

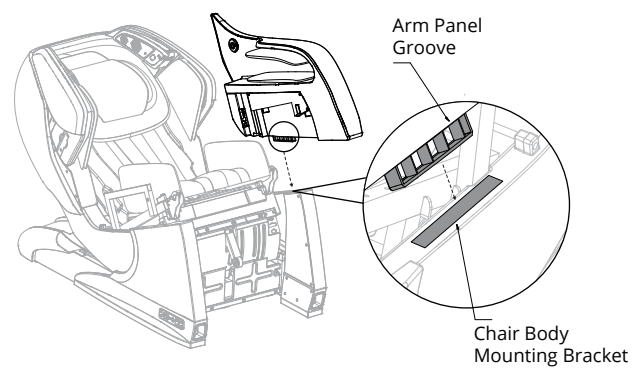

7 Step 7: Insert an **M5x45 screw and large washer** into the screw hole located inside the circular cut-out on the outside of the arm panel. Tighten using the screwdriver. Attach the arm panel cap found in the accessory box. Each cap is labeled with its respective side, ensure the correct cap is placed in the correct arm panel. To secure the arm panel cap, place it into the cut-out with the arrow facing up, then twist clockwise until you hear the cap snap into place.

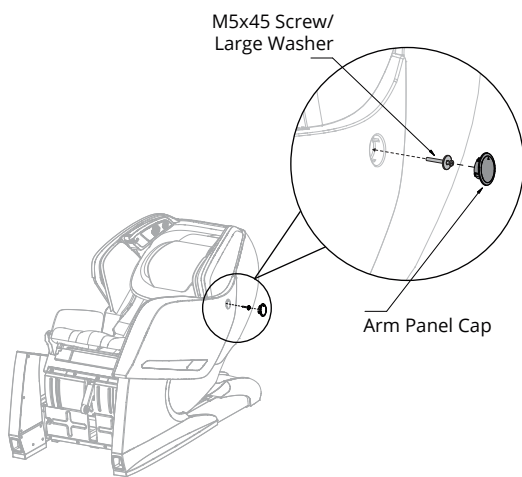

8 Step 8: Locate the square cut out with a screw hole found on the inside of the arm panel underneath the hip airbag. Peel back the hip airbag, then insert an **M6x16 with pre-installed washer** screw into the screw hole and tighten using the screw driver. **Repeat steps 5-8** on other arm panel.

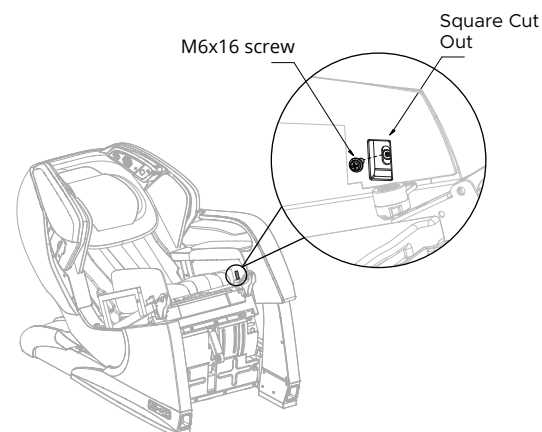

9 Step 9: Plug the remote control cord into the remote control port located on the front right of the chair body. Ensure the **arrow** on the remote control cord lines up with the **arrow** on the remote control port before inserting. Screw on metal ring to fasten. Do not force.

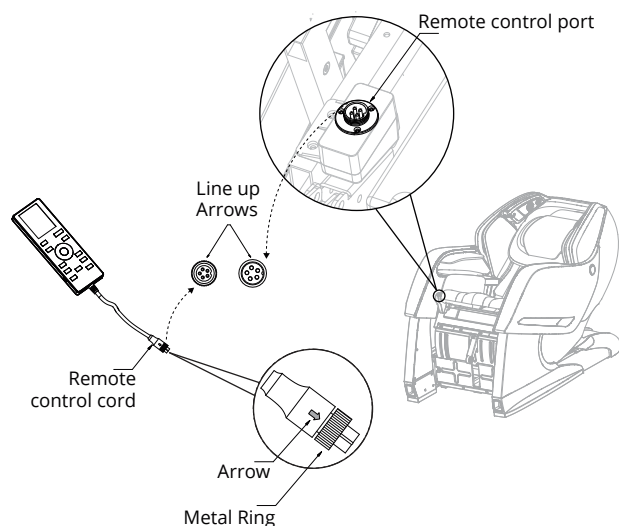

10 Step 10: Connect the chair power cord to a grounded 110V electrical outlet and plug it into the respective port on the side of the base of the chair. Flip the main power switch to on.

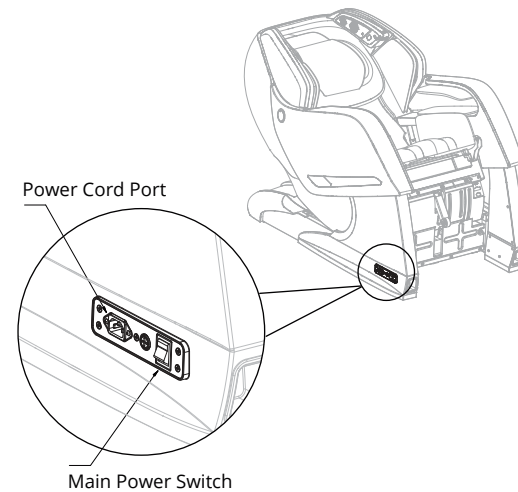

11 Step 11: Press the power button on the remote control twice. Once to turn on the remote control, and again to upright the chair out of the shipping position.

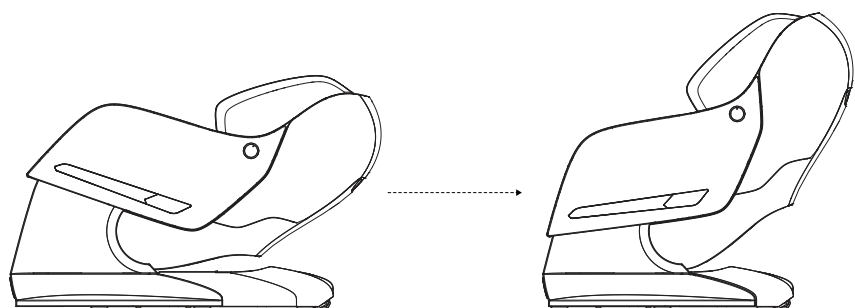

12 Step 12: Remove footrest from packaging and position in front of chair body. Connect footrest by attaching the electrical plugs from the footrest into their respective ports on the body of the chair - **make sure to match the correct size plug to the correct port**. Ensure the thumb release is facing up and push in until it snaps. Slide the air hose onto the white air nozzle.

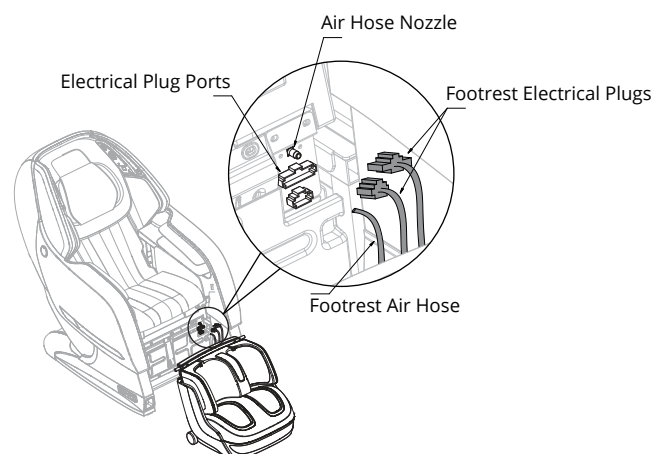

13 Step 13: Locate the two footrest axle sleeves found in the accessory box. Slide the axle sleeves onto the ends of the footrest axle, making sure the thicker side of the axle sleeve goes onto the axle first.

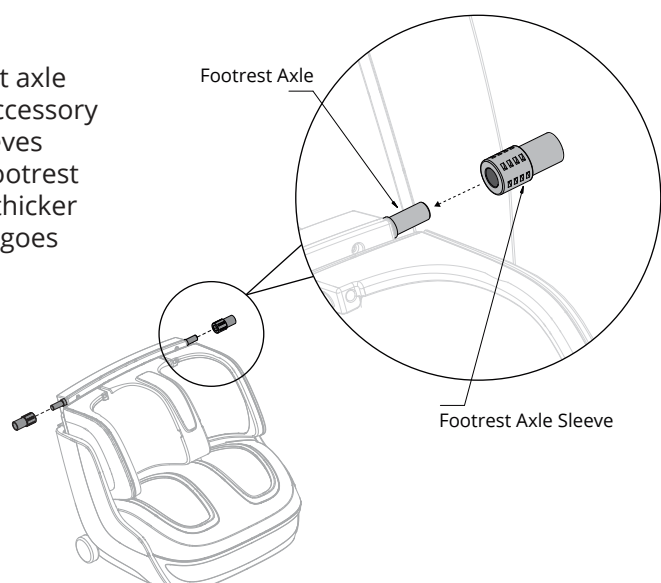

14 Step 14: Remove the protective covering from the footrest hanger in the footrest well. The protective covering should slide straight off as shown. Discard after removing.

