



FEATURES

- Oil lubricated rotary vane vacuum pump, nominal speed 282 cf/h (8 m³/h);
- Time controled vacuum level;
- Maximum vacuum 99.8% (2 millibars);
- 12,4" sealing bar, easily removable for cleaning;
- Removable sealing bar lifting device, with sealing cap for cleaning
- Waterproof digital control panel with six keys and 3+3 digit display;
- 10 editable programs;
- Program for vacuum packaging ("Jars"-key) in containers using a special valve connection;
- Adjustable sealing intensity;
- Pump oil dehumidification program;
- Resettable oil change alarm;
- Analog vacuum gauge for displaying the vacuum level
- AISI304 Stainless steel vacuum chamber and bodywork; pump oil drain of the machine body with cover, which prevents the penetration of impurities or insects inside;
- High-thickness blued PMMA (Plexiglass) lid with polished and rounded edges; opens automatically at the end of the cycle;
- Chromed aluminum die-cast hinges;
- Thermal welding protection system;
- Accessory "Easy" for external vacuum in embossed bags;
- 3 PE-filling plates for product adjustment and cycle speed up;

DESCRIPTION

The basic model Multiple 315H, made entirely of AISI304 stainless steel, equipped with a digital control panel, stands out for its extreme robustness, ease of use and compactness. Its versatility makes it possible to package the products in the chamber, in external containers via the suction device and in embossed envelopes outside the chamber. The quality and proven reliability of the machine and its components derives from the over twenty-year widespread presence on the global market, in all areas and all sectors.



SEALING BAR 12.4 inch
VACUUM PUMP 282 cf/h

ACCESSORIES

- Vacuum bags for storage, cooking, "cook & chill"; embossed bags;
- Stainless steel cart with castors and shelf
- Inclined stainless steel plate for liquid packing
- Suction device for external containers;



Intertek Intertek

According to:
UL197 / NSF Hygienic standards

PROJECT	DATE	APPROVED
ITEM	QTY	

VACUUM PACKAGING MACHINES MULTIPLE315H

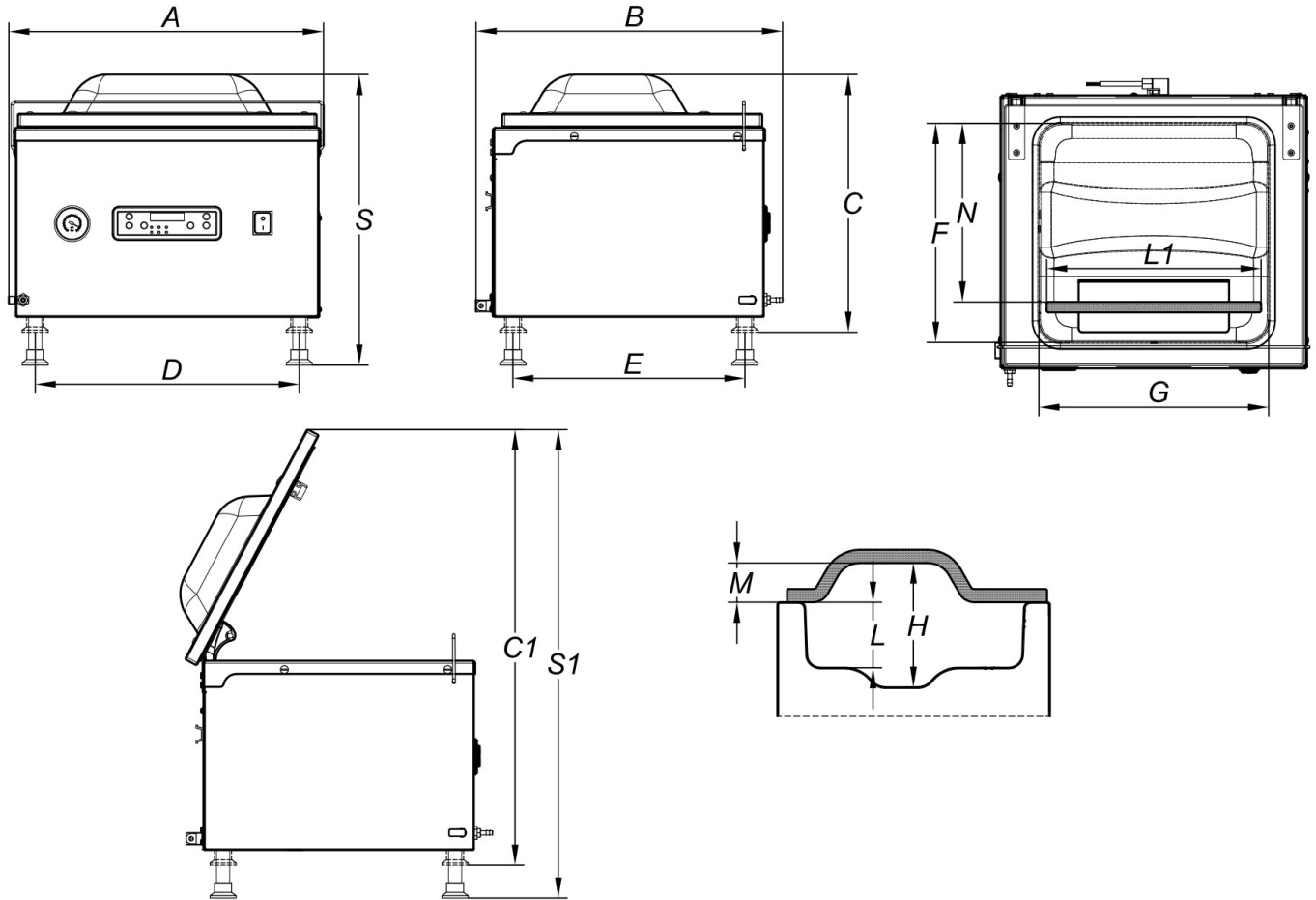

SPECIFICATIONS

Length of seal L1	inch	12,4
Nominal pump speed	cf/h	282
Final pressure	mbar	2
Chamber size (FxGxH)	inch	13,1x13,8x7,5
Useful chamber space (N)	inch	10,7
Tank depth (L)	inch	3,9
Chamber volume	Usgal	3,96
Power	W	620
Electrical voltage/Frequency/Phases	V/Hz	110v / 60Hz / 1Ph+N+PE
Power cord and plug		118,11 inch / Nema 5
Current	A	5,63
Housing materials		AISI304
Vacuum chamber material		AISI304
Lid material		PMMA (plexiglas)
Overall dimensions (AxBxS)	inch	18,9X18,5X17,5
Overall dimensions (AxBxC)	inch	18,9x18,5x15,5
Maximum height with open lid (S1)	inch	28,1
Maximum height with open lid (C1)	inch	26,2
Distance between supports (DxE)	inch	15,9x14
Weight (with filling plates)	lbs	82,7
Noise level	dB(A)	58
Environmental operating temperature (min-max)	°F	53,6-104