

Assembling Instruction

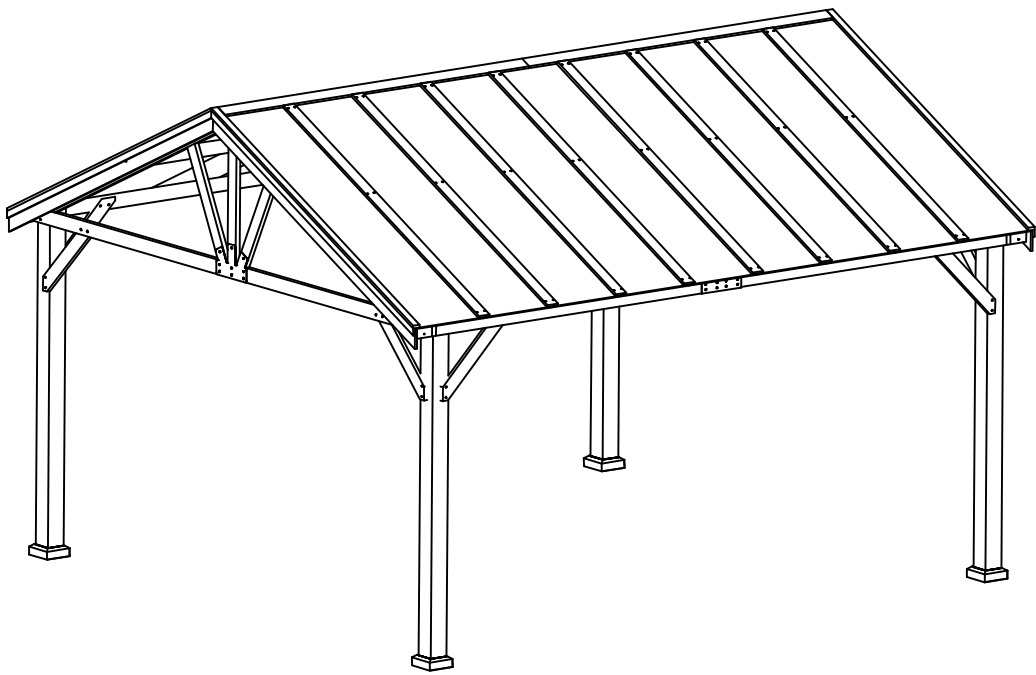

ITEM#: XWG208





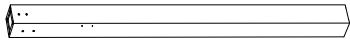
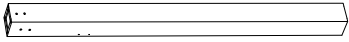

SKU: XWG208

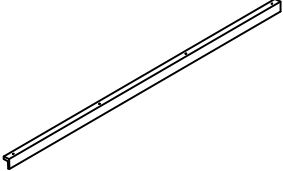
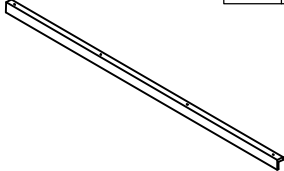
- ATTENTION:
1. Please check the manual carefully and make sure you have received all the parts.
 2. If there is any missing, please let us know the letter of the parts you need.
 3. If there is any damage, please send clear photos to us, we will check and offer you best solution soon.

Parts List (Box A)

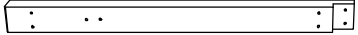
 <p>AA X2</p>	 <p>BB X2</p>	 <p>LL X16</p>
 <p>NN X2</p>	 <p>OO X2</p>	

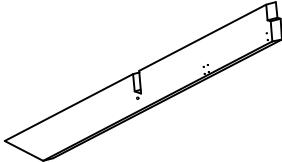
Parts List (Box B)

 <p>EE X4</p>	 <p>FF X2</p>	 <p>GG X2</p>
 <p>HH X2</p>	 <p>II X2</p>	 <p>JJ X2</p>

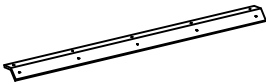
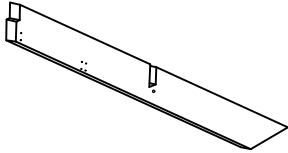
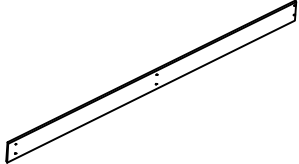
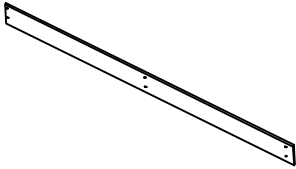

Parts List (Box C)

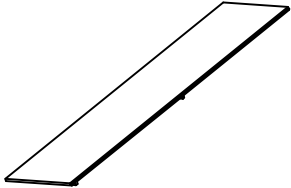
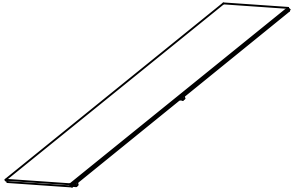
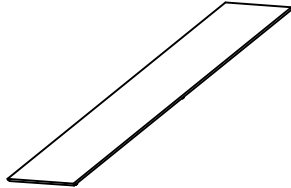



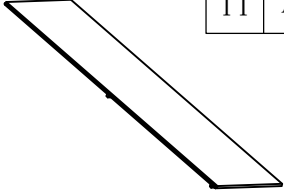
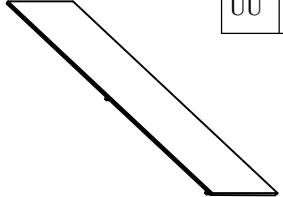
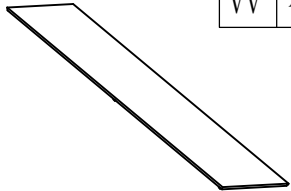









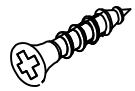
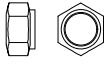

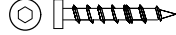
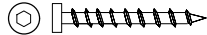
		
--	--	--

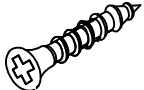
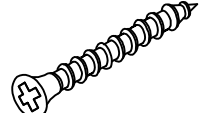

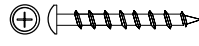
Parts List (Box D)

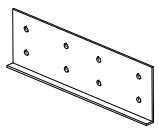
		
---	---	---

Parts List (Box E)

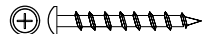
		
---	---	---

CC		x4		DD		x4	
							
A	x16+(1)	B	x58+(1)	C	x16+(1)	D	x48+(2)
M8*165mm		M8*45mm		M8*55mm		M4*20mm	
							
E	x90+(2)	F	x82+(2)	G	x16+(1)	H	x32+(1)
M8		ø20*1.4mm		M6*40mm		M6*55mm	
							
I	x1	J	x16+(1)	K	x6+(1)	L	x100+(2)
M6		M5*30mm		M5*80mm		M4*25mm	
							
M	x36+(2)	N	x4	O	x4	P	x10
M4*50mm		173*173mm		160*160mm		300*93mm	
							
Q	x2	R	x8	S	x4	T	x64+(2)
M8		ø8*180		M6*89mm		M4*60mm	
							

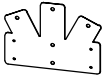
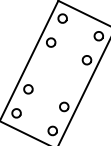
<table border="1" data-bbox="347 206 507 291"> <tr> <td>U</td> <td>x4</td> </tr> <tr> <td colspan="2">M6*65mm</td> </tr> </table> 	U	x4	M6*65mm		<table border="1" data-bbox="662 206 798 291"> <tr> <td>V</td> <td>x12</td> </tr> <tr> <td colspan="2">ø8*30</td> </tr> </table> 	V	x12	ø8*30		<table border="1" data-bbox="960 206 1093 291"> <tr> <td>W</td> <td>x3</td> </tr> <tr> <td colspan="2">200*100mm</td> </tr> </table>  <p>Asphalt tile</p>	W	x3	200*100mm		<table border="1" data-bbox="1264 206 1396 291"> <tr> <td>X</td> <td>x2</td> </tr> <tr> <td colspan="2">300*230mm</td> </tr> </table> 	X	x2	300*230mm	
U	x4																		
M6*65mm																			
V	x12																		
ø8*30																			
W	x3																		
200*100mm																			
X	x2																		
300*230mm																			
<table border="1" data-bbox="375 510 507 593"> <tr> <td>Y</td> <td>x6</td> </tr> <tr> <td colspan="2">80*38mm</td> </tr> </table> 	Y	x6	80*38mm																
Y	x6																		
80*38mm																			

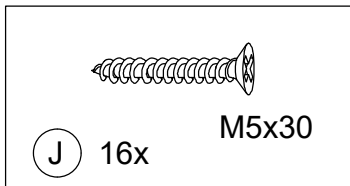
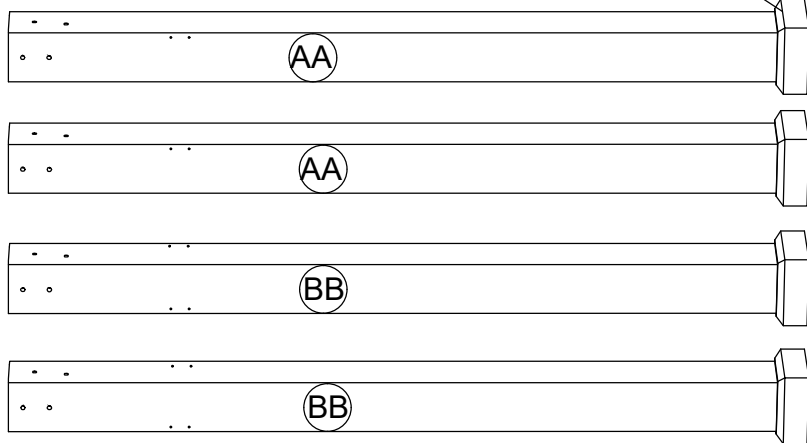
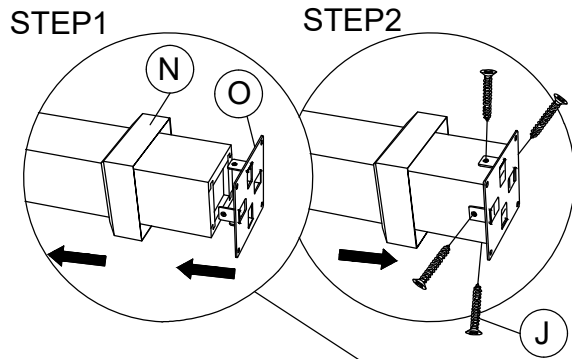
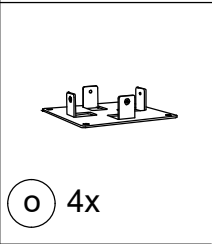
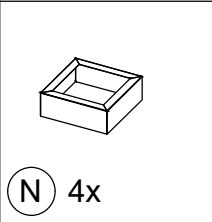
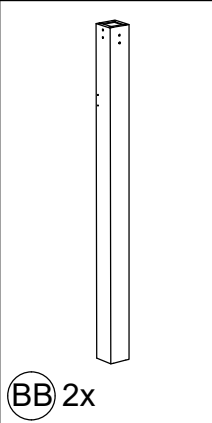
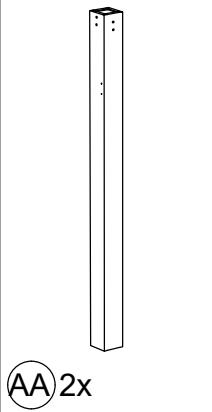

Step1

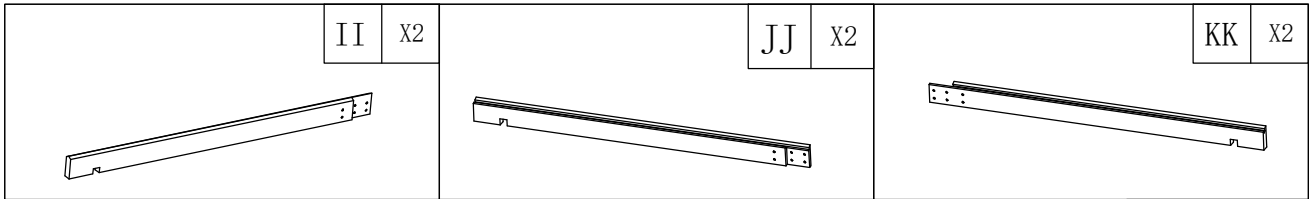

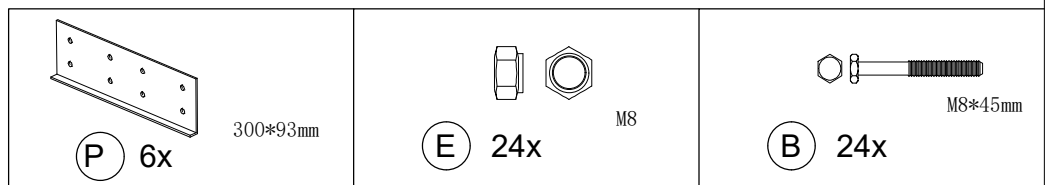
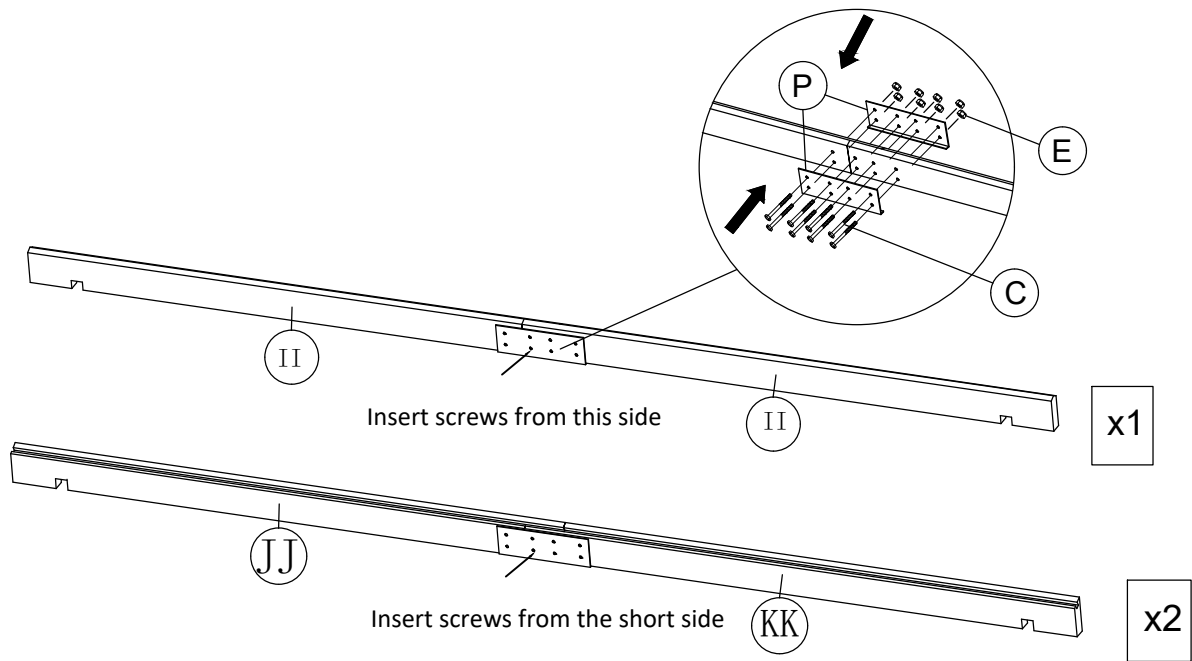

Step2



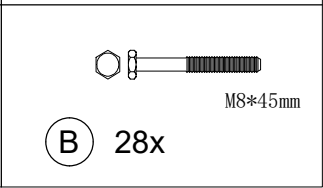
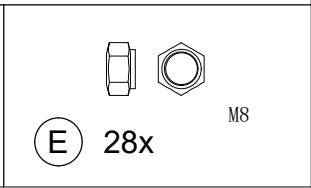
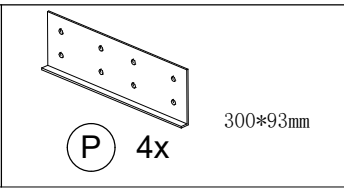
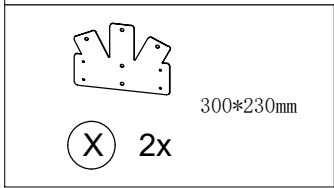
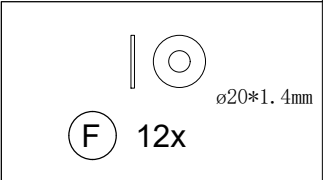
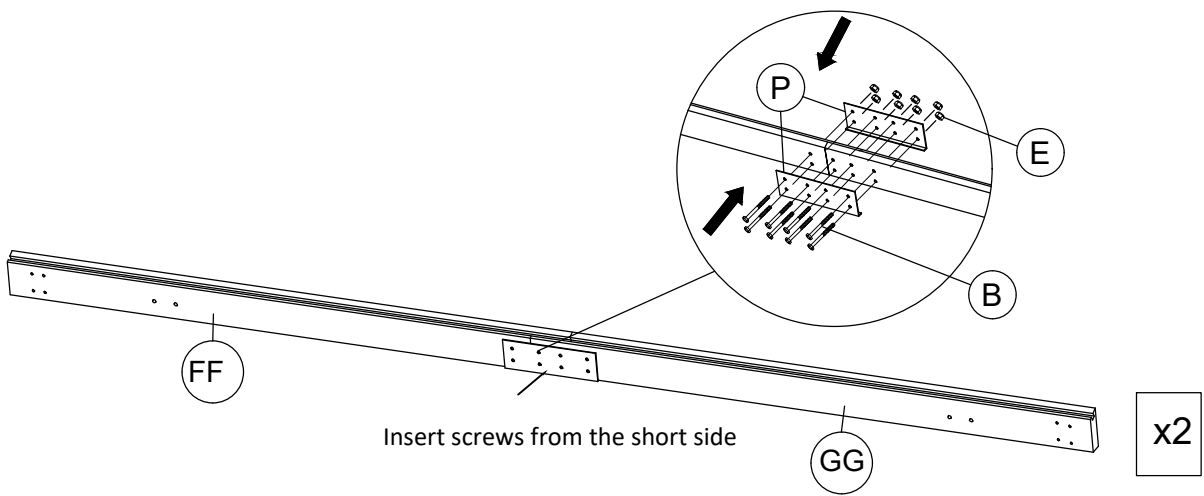
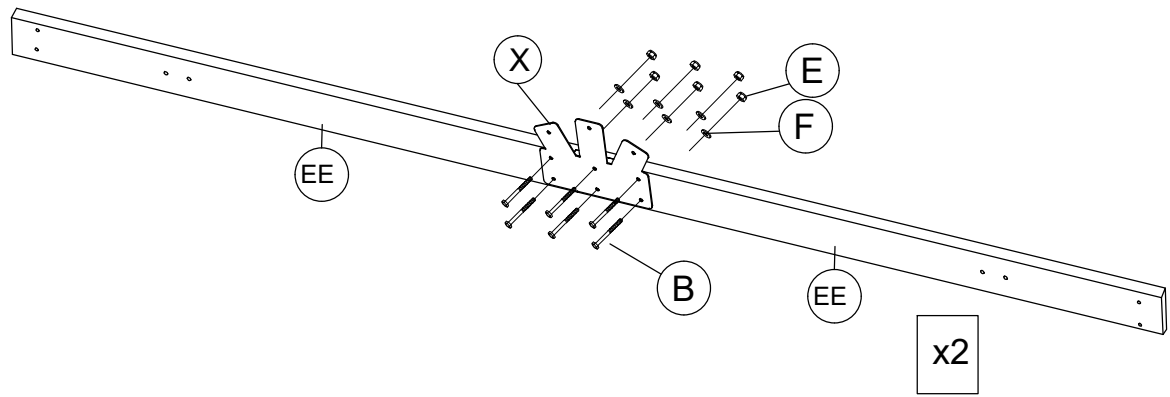

<table border="1"> <tr> <td>EE</td> <td>X4</td> </tr> </table> 	EE	X4	<table border="1"> <tr> <td>FF</td> <td>X2</td> </tr> </table> 	FF	X2	<table border="1"> <tr> <td>GG</td> <td>X2</td> </tr> </table> 	GG	X2
EE	X4							
FF	X2							
GG	X2							

Step3

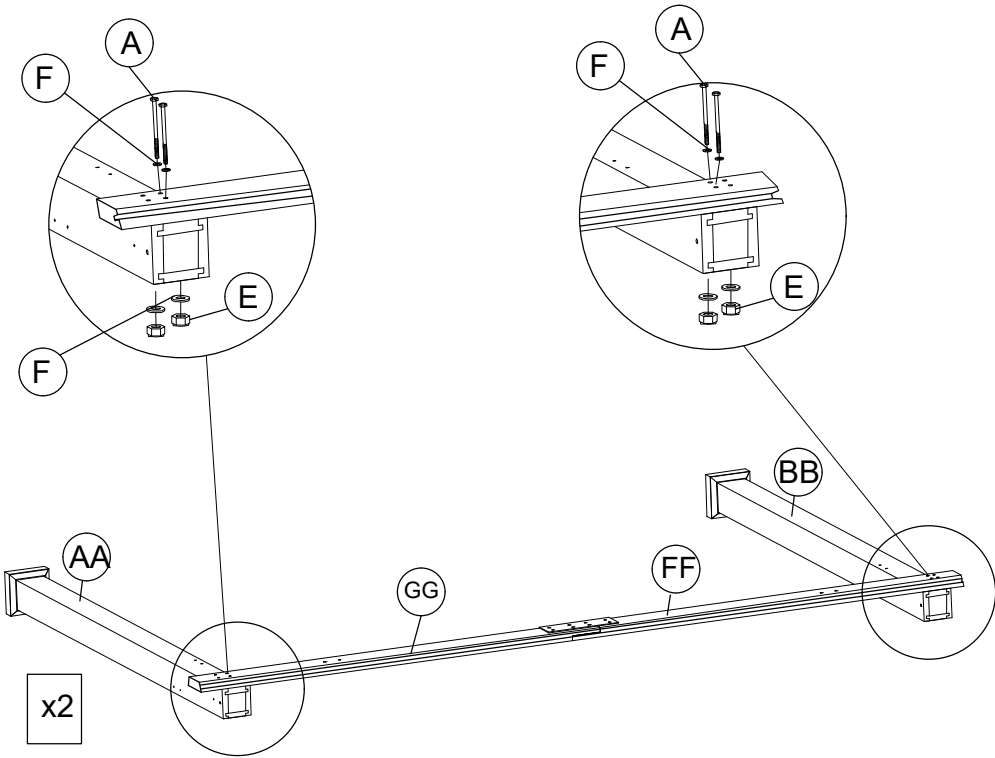

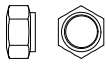

 (A) 8x M8*165mm	 (F) 16x $\phi 20 \times 1.4 \text{mm}$	 (E) 8x M8
---	---	---

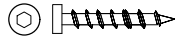
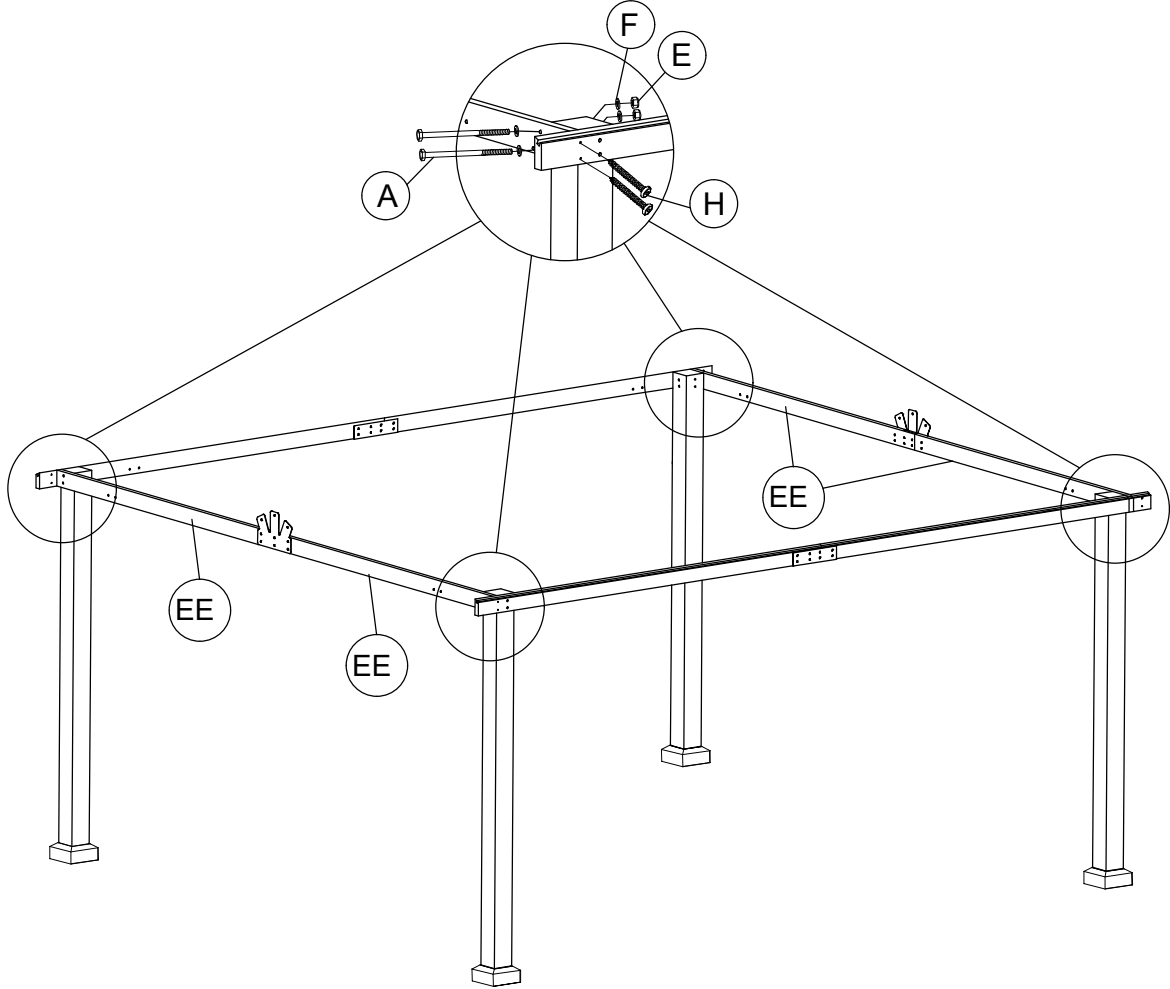

M6*55mm

(H) 8x



M8*165mm

(A) 8x



ø20*1.4mm

(F) 16x

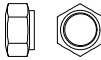

M8

(E) 8x

CC X4

DD X4

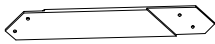

Step6

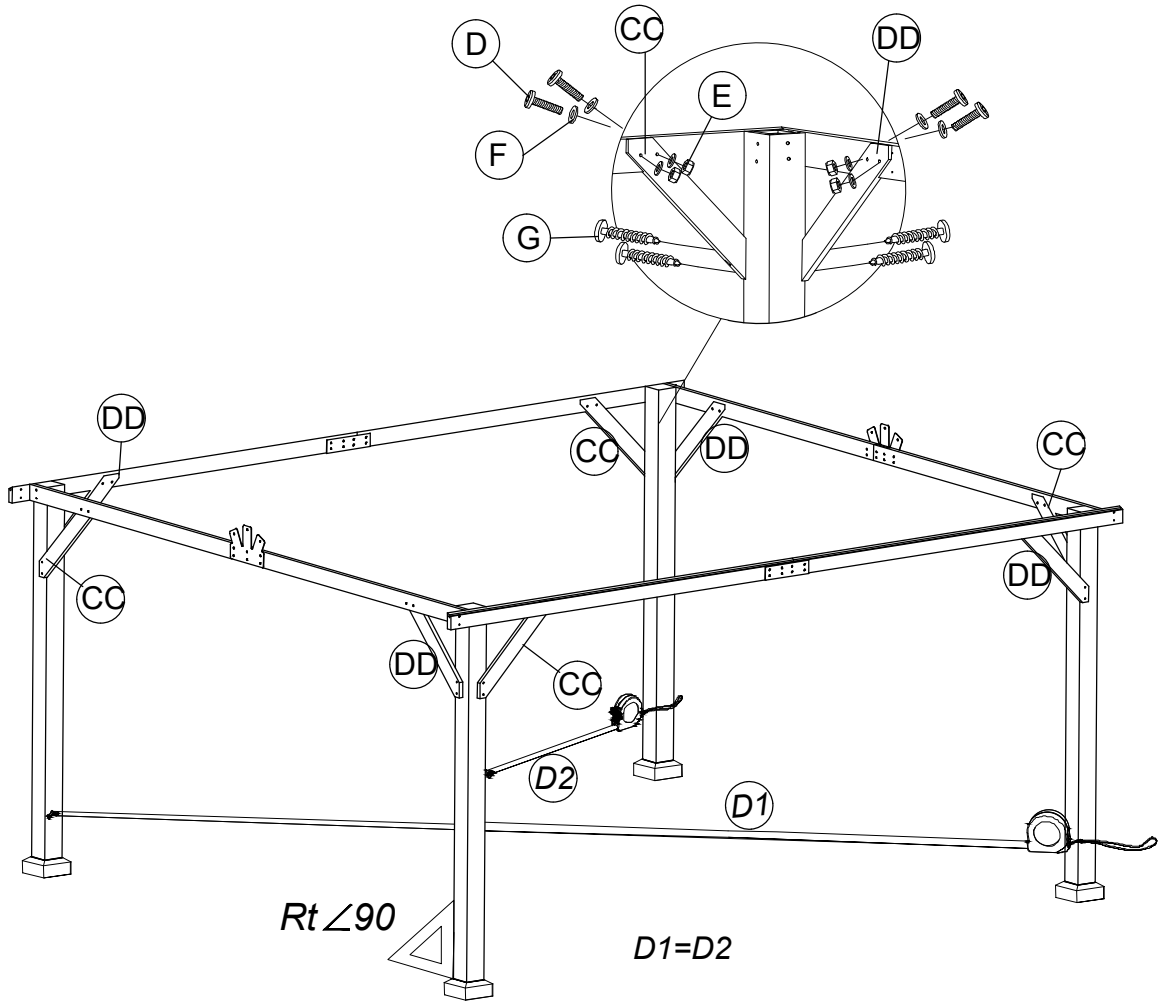

M8*55mm

(C) 16x



$\phi 20 \times 1.4 \text{mm}$

(F) 32x

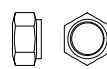

M8

(E) 16x

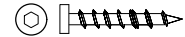

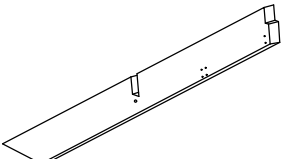
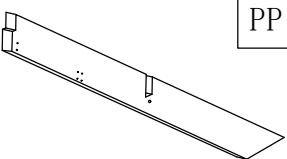
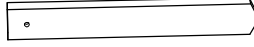
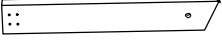
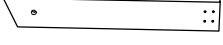

M6*40mm

(G) 16x

	HH	x2		PP	x2		WW	x2
	XX	x2		YY	x2			

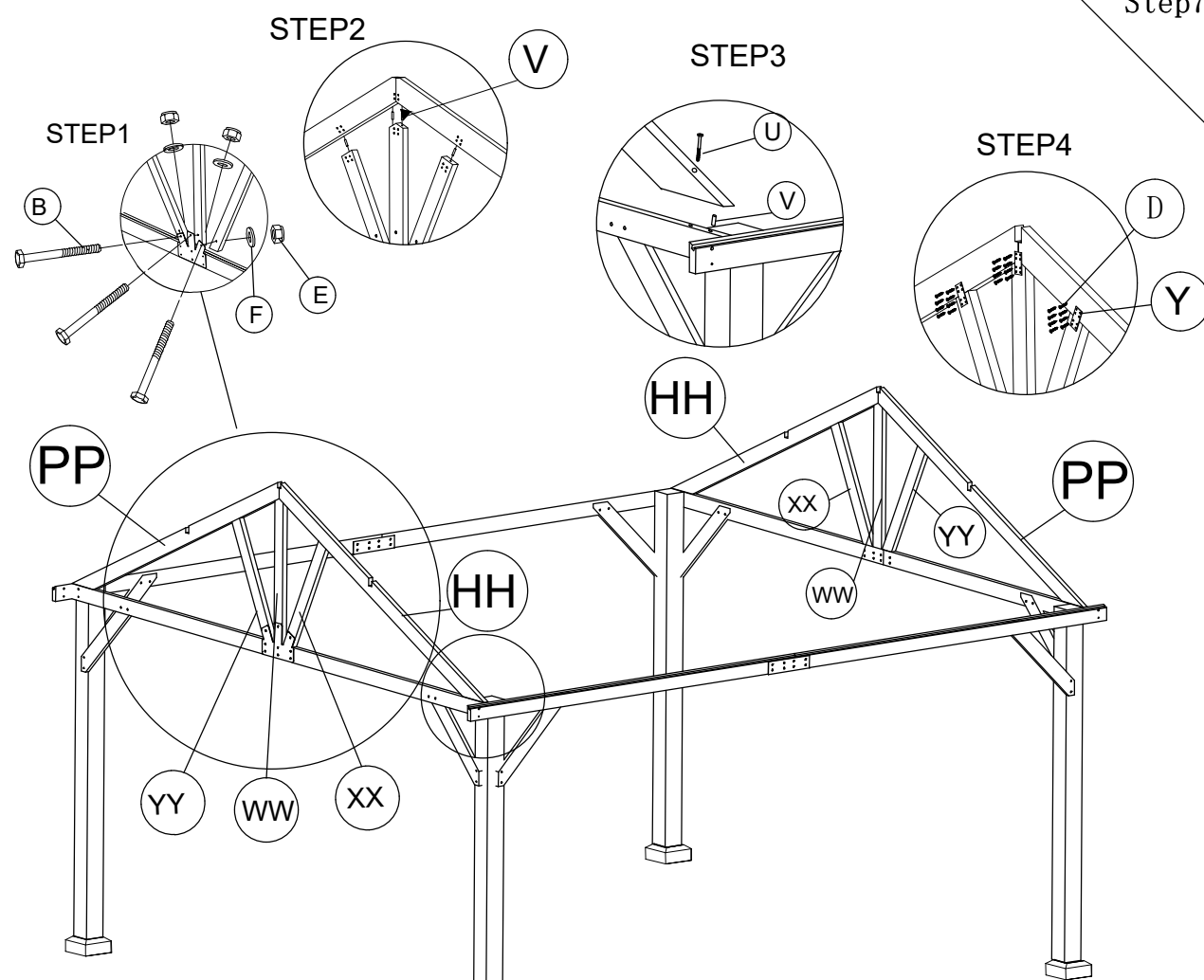
Step7

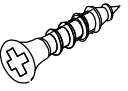
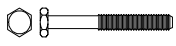
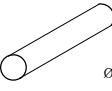
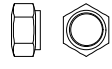
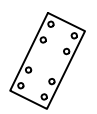
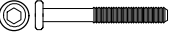

	M4*20mm		M8*45mm		ø20*1.4mm		M8
(D) 48x		(B) 6x		(F) 6x		(E) 6x	
	80*38mm		M6*65mm		ø8*30		
(Y) 6x		(U) 4x		(V) 12x			

Step8

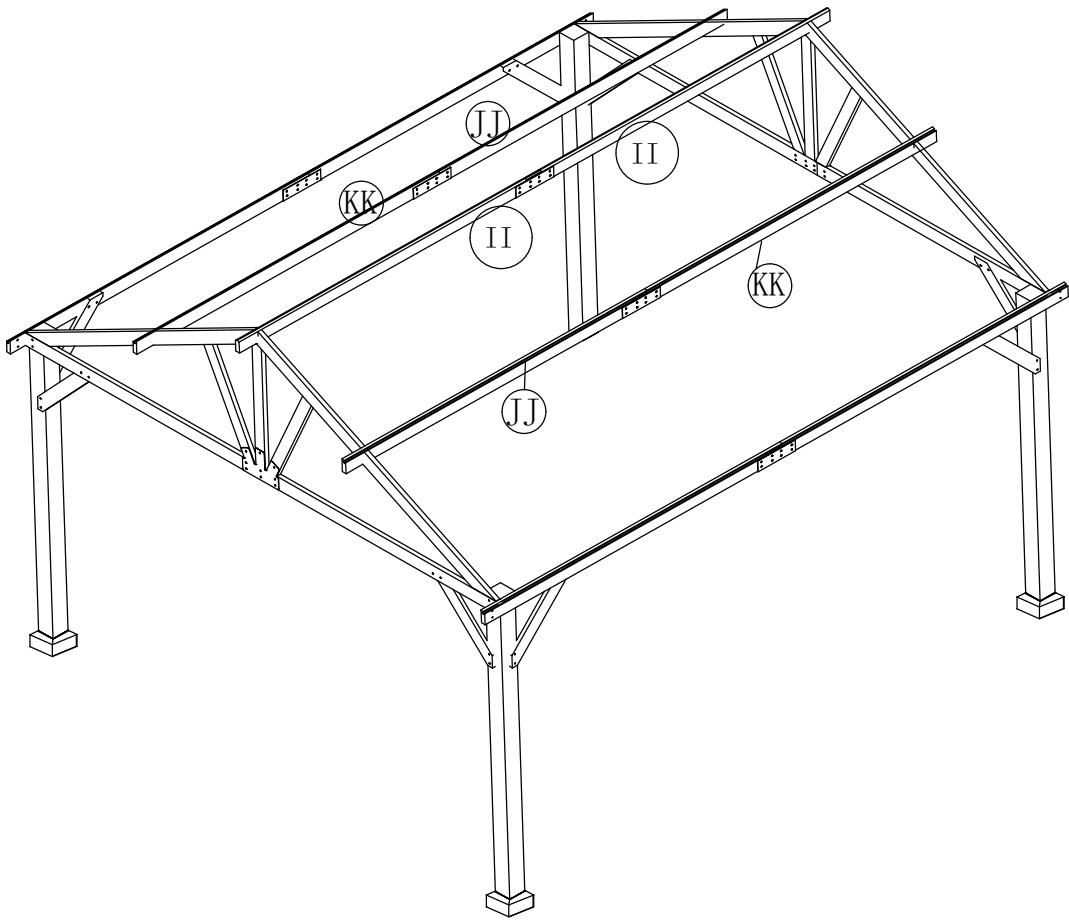

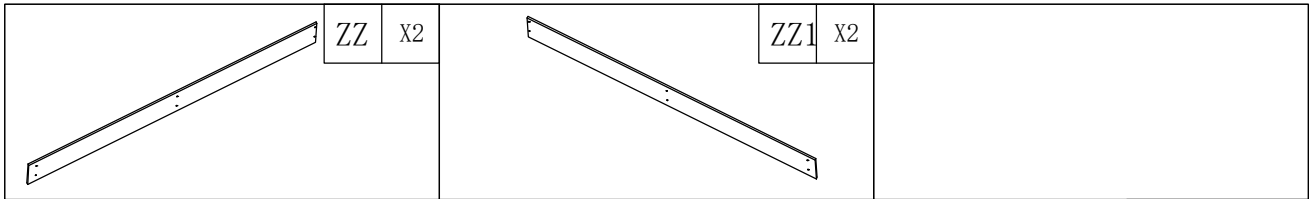

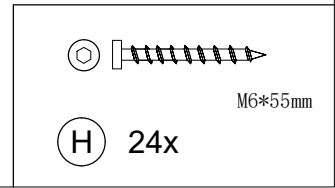
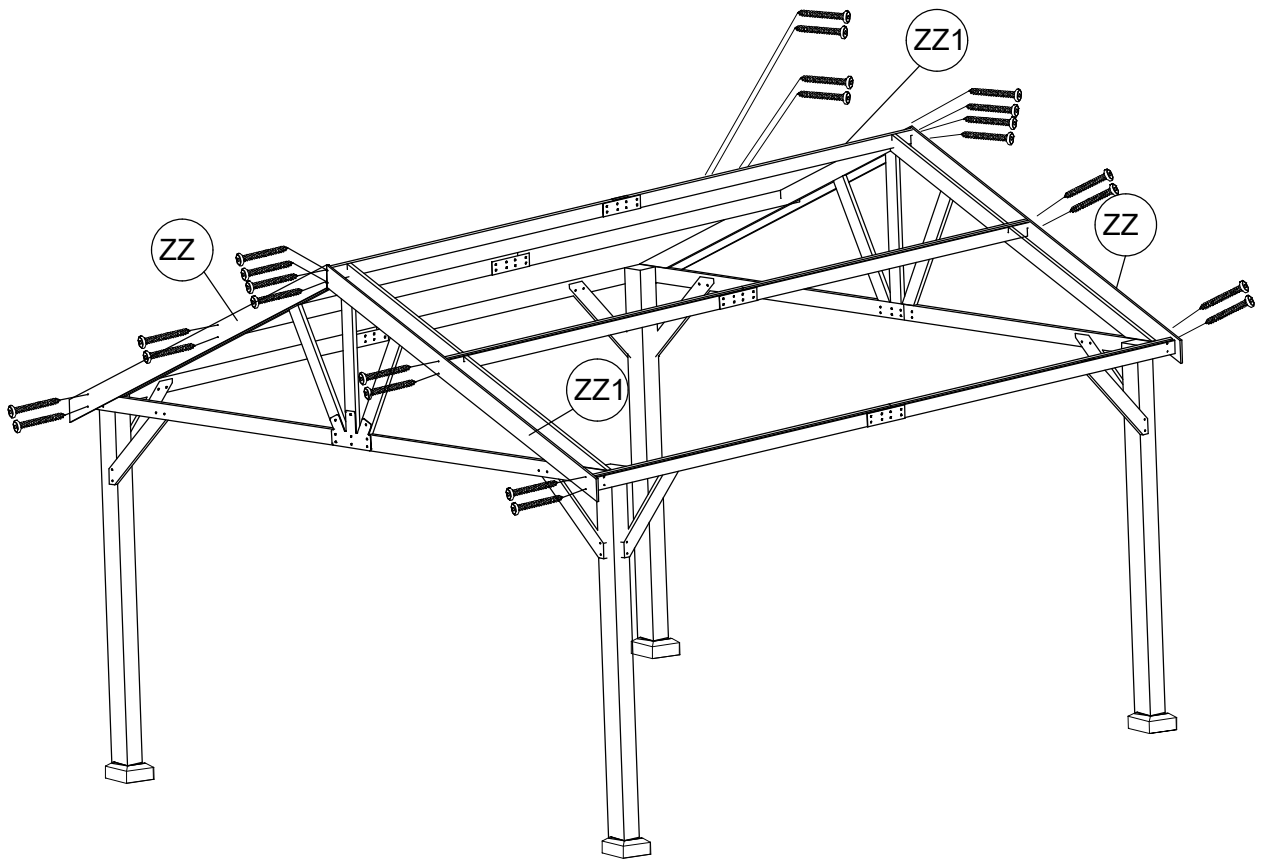

Step9

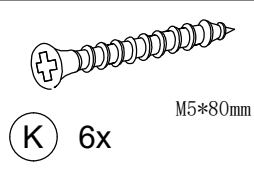
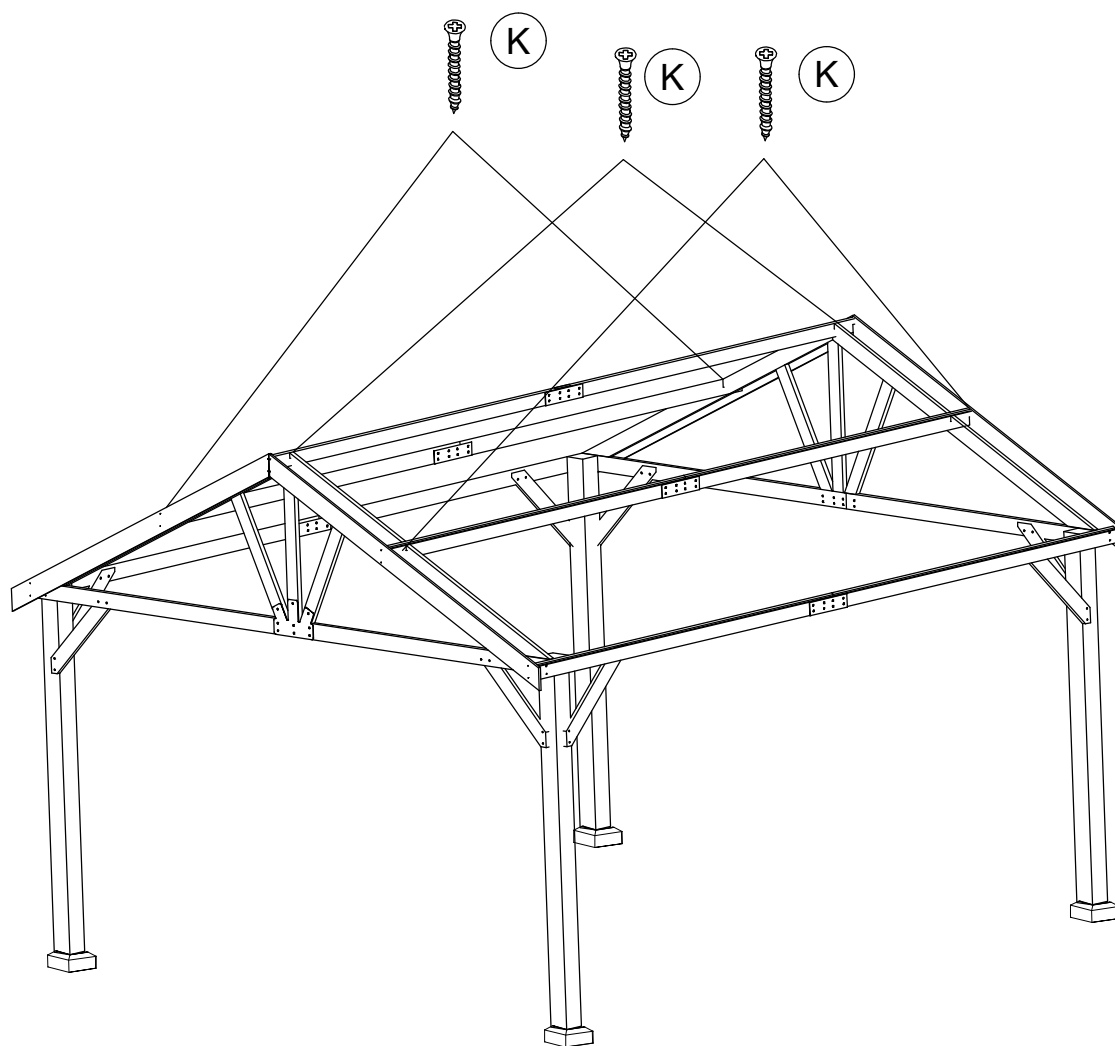

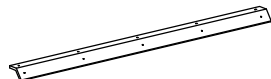

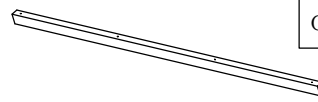
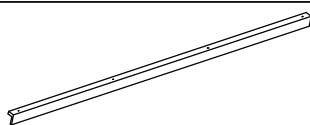
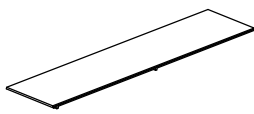
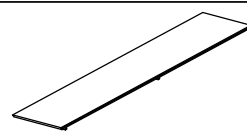
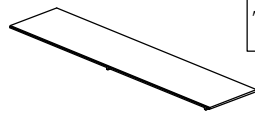
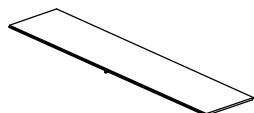
	MM X1		LL X10		OO X1
	NN X1		QQ X1		RR X5
	TT X1		UU X5	Step11	

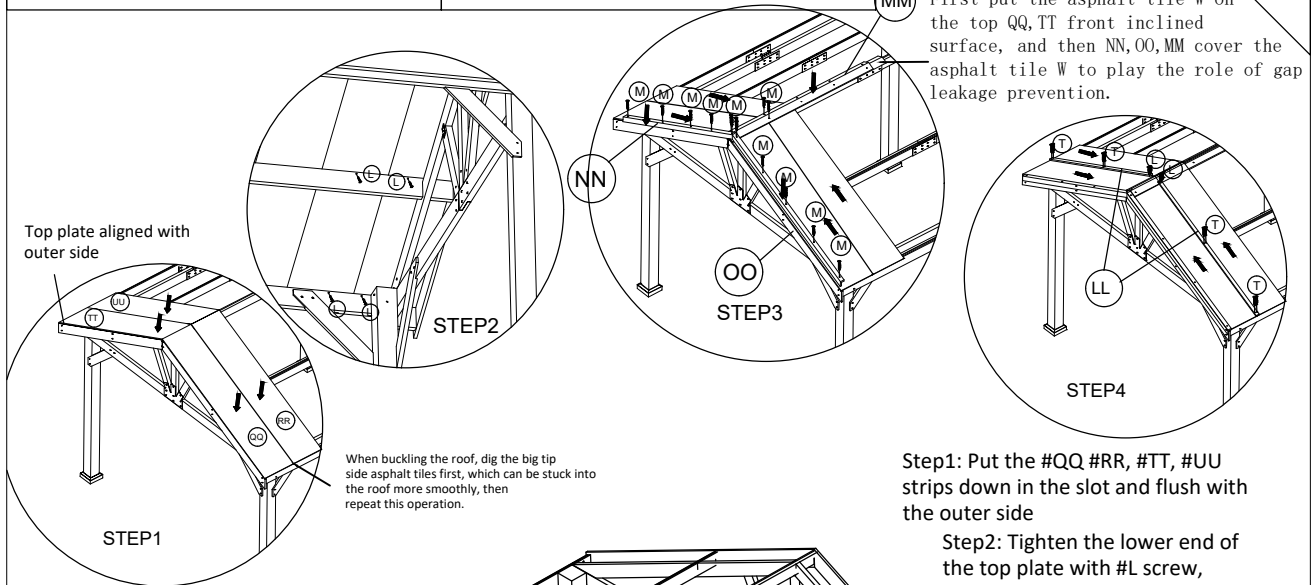

When buckling the roof, dig the big tip side asphalt tiles first, which can be stuck into the roof more smoothly, then repeat this operation.



Step1: Put the #QQ #RR, #TT, #UU strips down in the slot and flush with the outer side

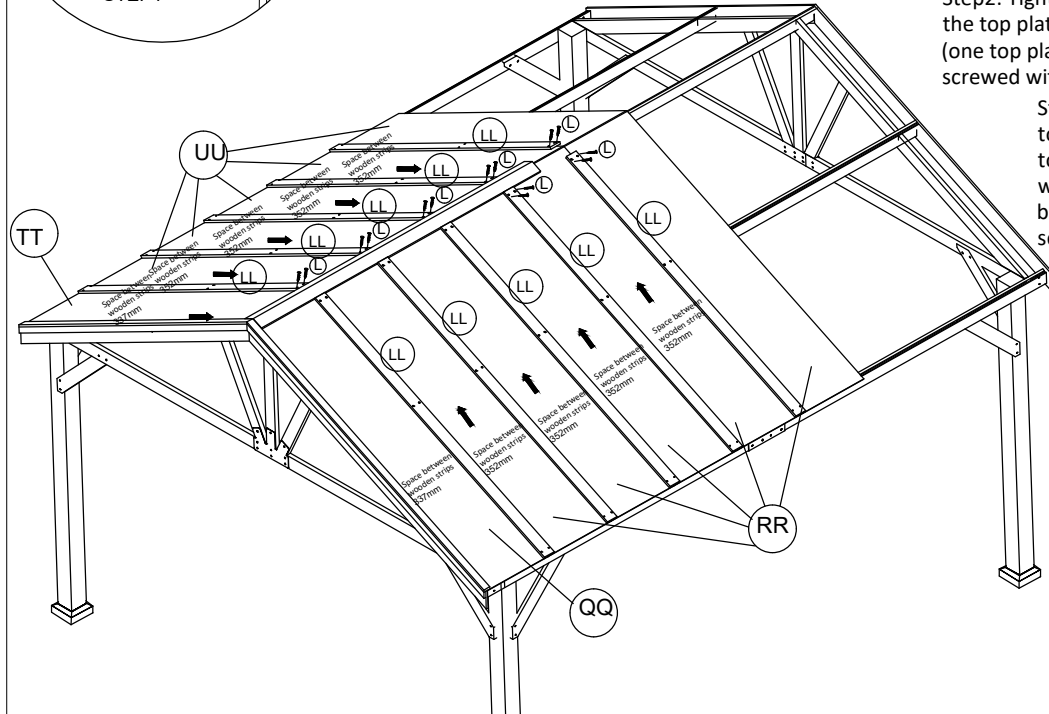

Step2: Tighten the lower end of the top plate with #L screw, (one top plate needs to be screwed with 2 screws)

Step3: #MM cover at the top. #NN and #OO need to be aligned closely with the top plate and beveled side and then screw on the #M screws

Step4: Put the #LL strip on the joint of the two top plates (the side with the smaller distance between the hole and the edge faces #MM), align the upper end with #MM, and then screw on the #T, #L screws. Then repeat this operation, insert the top plate #RR, #UU, tighten the lower end of the top plate with #L screw, then put #LL strip, and screw on #T, #L screw

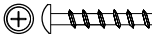
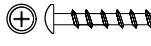

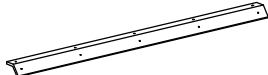
			
Asphalt tile	M4*25mm	M4*50mm	M4*60mm
(W) 2x 200*100mm	(L) 44x	(M) 20x	(T) 40x

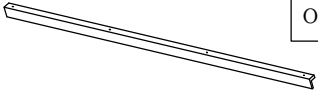
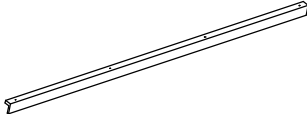
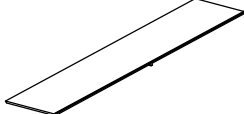
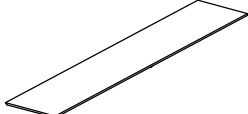
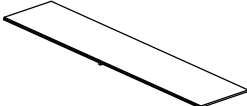
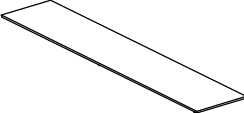
	MM X1		LL X6		OO X1
	NN X1		RR X2		SS X1
	UU X2		VV X1	Step12	

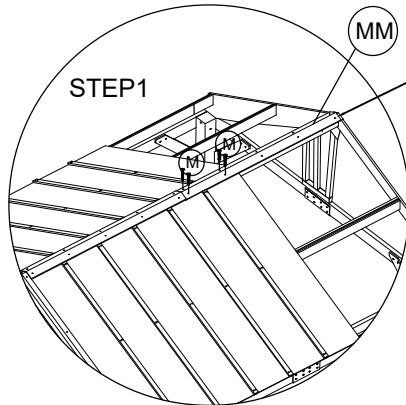

#MM top cover asphalt shingles, and long side facing outwards

Step1: #MM cover at the top. Repeat the previous step, put the #LL strip, screw #T, #L screws, align the #OO, #NN cover with the top plate and the beveled side, then screw #M screws

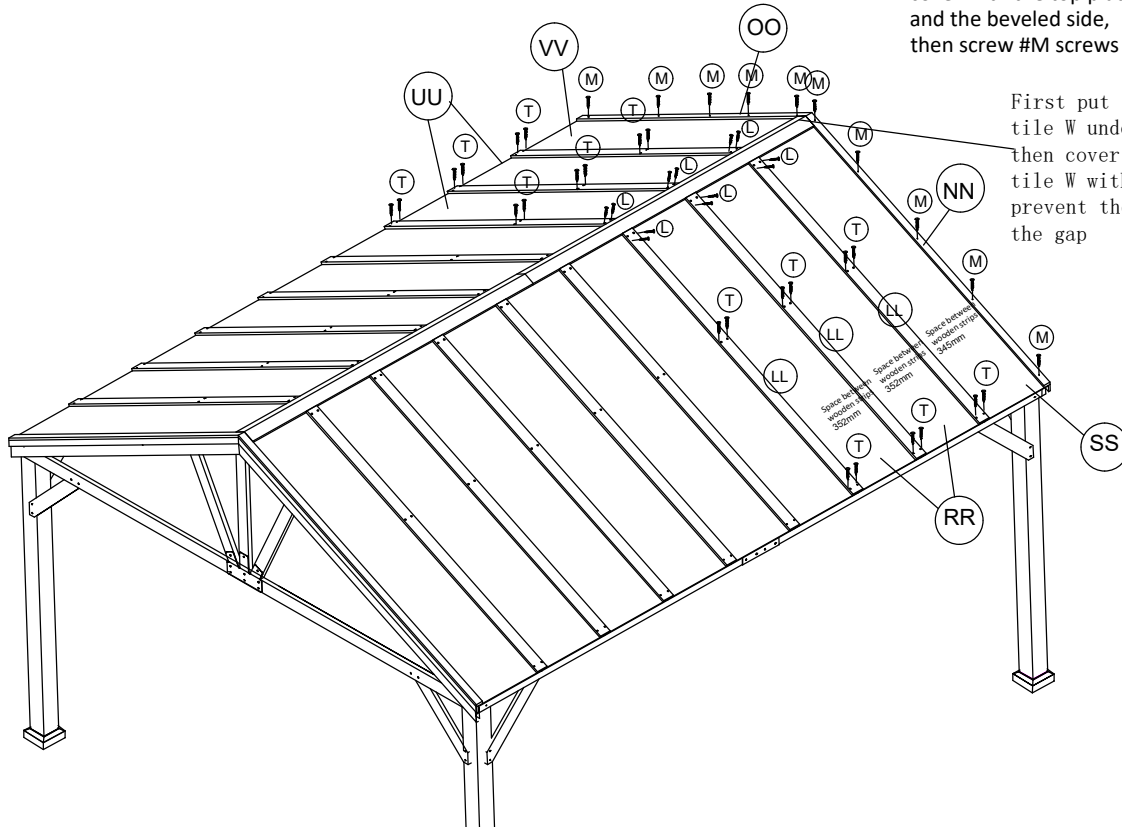

First put the asphalt tile W under MM, and then cover the asphalt tile W with MM, NN, OO to prevent the leakage of the gap

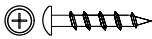
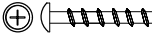
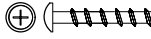
 Asphalt tile (W) 1x 200*100mm	 (L) 12x M4*25mm	 (M) 20x M4*50mm	 (T) 24x M4*60mm
---	--	---	--

Step13

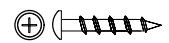
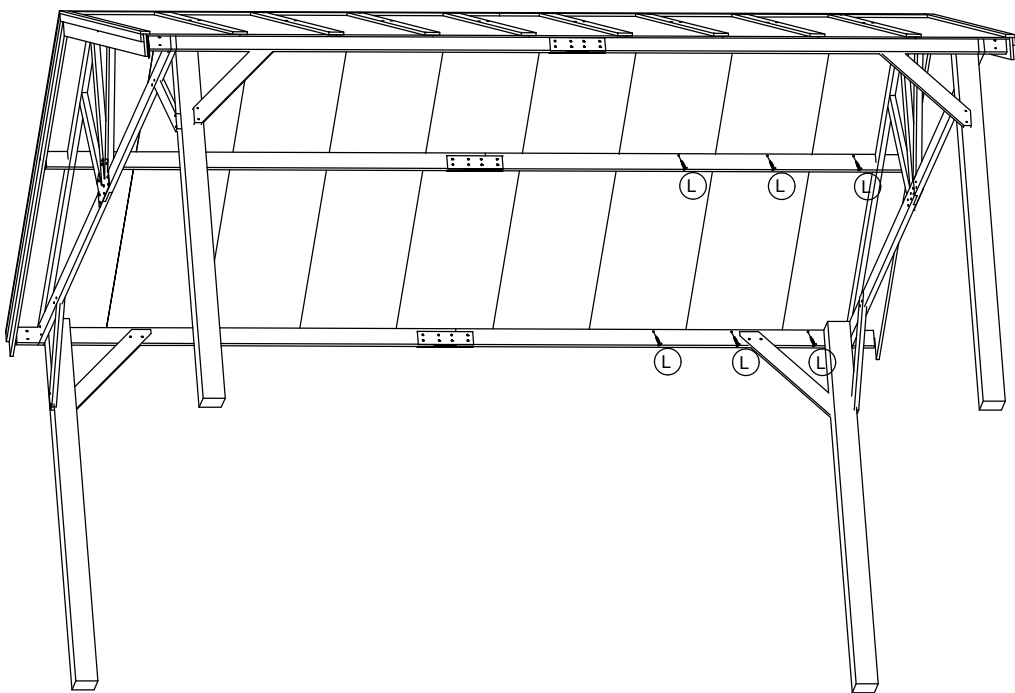

M4*25mm

L 12x

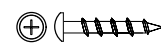
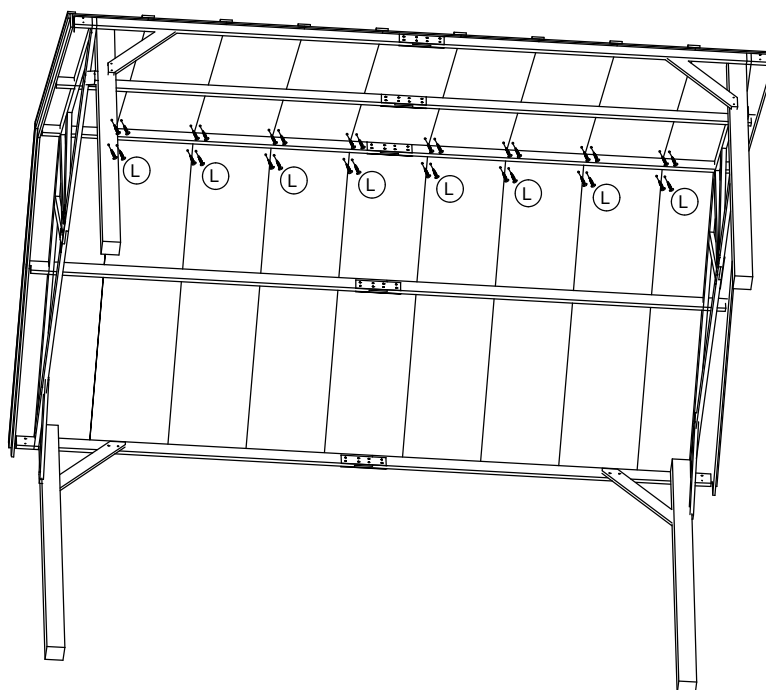

M4*25mm

L 32x

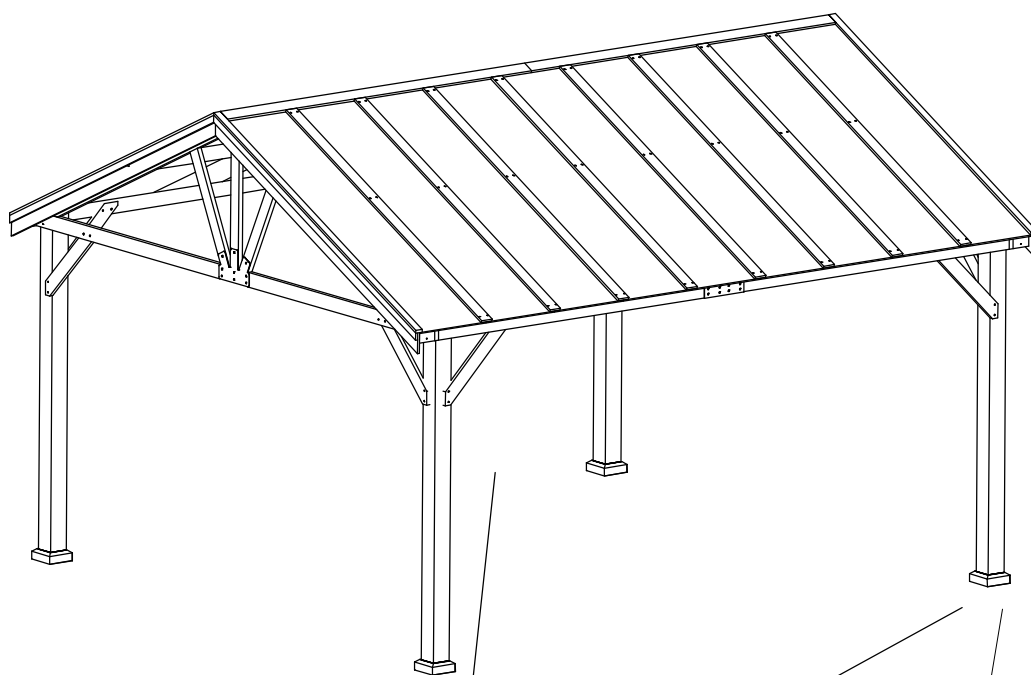

#S hooks can be freely assembled under the wooden beam

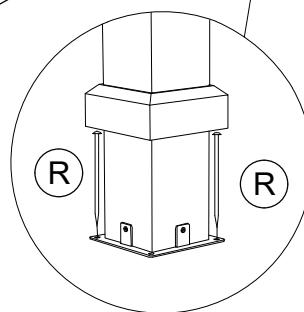
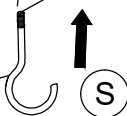

*You can choose where to mount the hooks according to your needs, but be careful when screwing the hooks into the wood or you may crack the wood slightly

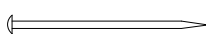
 M6*89mm S 4x	 ø8*180mm R 8x
--	---