

INSTRUCTION MANUAL

SKU: XWG-203-2

12FT x 20FT GAZEBO

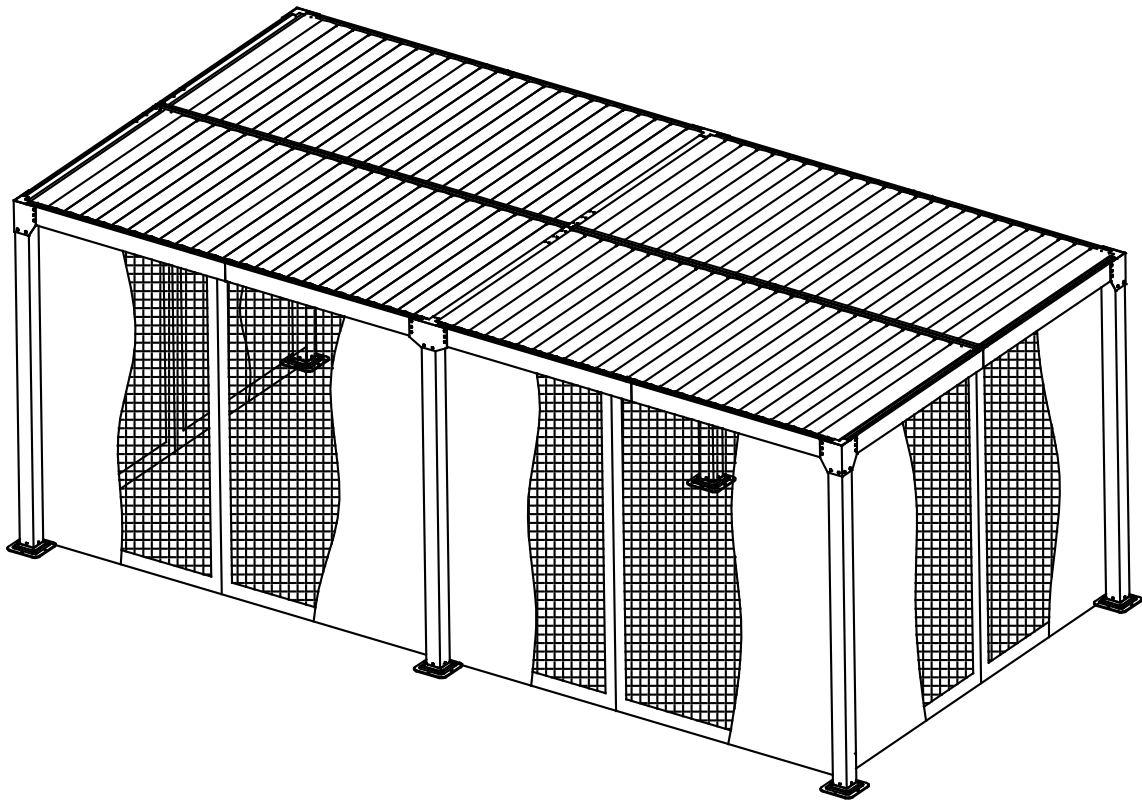

Note: The gazebo needs to be installed in cooperation with six people. The following tools are not included and needed for assembly:



Pistol Drill



Tape Measure

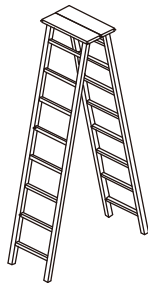

2 m Adjustable Ladder

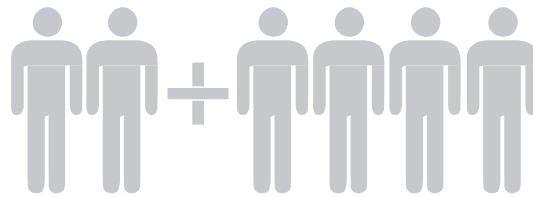

6 people







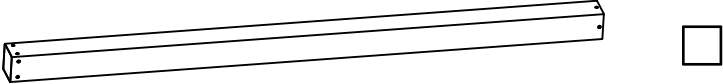

Warning

1. A 6 person assembly is required for this gazebo.
2. Please take appropriate actions as heavy rain, wind and snow can damage the gazebo. If necessary please disassemble and store for later use.
3. In snowy conditions, please do not allow the thickness of the snow to be more than 1.97 inches on the roof, this should be cleared as soon as possible for your safety. When the wind speed reaches 61.2km/h, please take measures to avoid the wind.

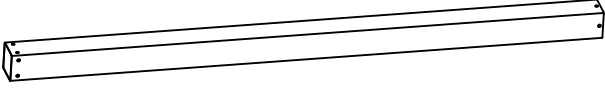

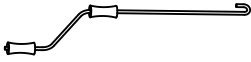

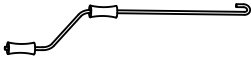
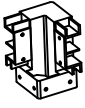
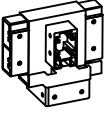



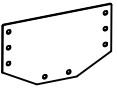
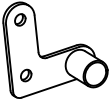
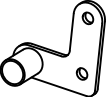

ATTENTION:

1. Please check the manual carefully and make sure you have received all the parts.
2. If there is any missing, please let us know the letter of the parts you need.
3. If there is any damage, please send clear photos to us, we will check and offer you the best solution soon.



Parts List (BOX A)

PART NO	DESCRIPTION	QTY	PART NAME
A		4	STANDING POLE
A1		2	STANDING POLE
F		2	MIDDLE BEAM FLUME COVERED
F1		1	MIDDLE BEAM FLUME COVERED
I		8	JOINT LEVER
J		2	CRANK
K		4	PLASTIC 4 CORNERS
K1		2	PLASTIC 4 CORNERS
L		4	MIDDLE BEAM FITTING
M		4	TURBINE (LEFT)
N		4	TURBINE (RIGHT)



Parts List (BOX A)

PART NO	DESCRIPTION	QTY	PART NAME
O		6	FOOT PLATE
P		4	FOOT TUBE PACKAGE
P1		2	FOOT TUBE PACKAGE
Q		4	FIXTURE (LEFT)
R		4	FIXTURE (RIGHT)
S		8	SIDE BEAM U TUBE
T		4	MIDDLE BEAM U TUBE
U		8	FLAT ALUMINUM BAR CONNECTOR
X		4	REVOLVING PART
PP		1	GLUE
LL		136	
MM		48	







Parts List (BOX B)

PART NO	DESCRIPTION	QTY	PART NAME
G		2	LOUVER BOARDS
H		60	LOUVER BOARDS

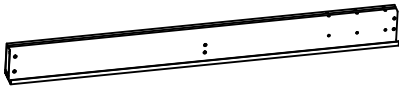

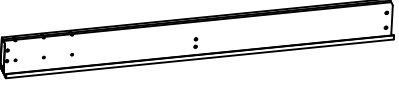









Parts List (BOX C)

PART NO	DESCRIPTION	QTY	PART NAME
G		2	LOUVER BOARDS
H		60	LOUVER BOARDS

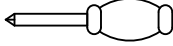
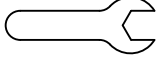

Parts List (BOX D)

PART NO	DESCRIPTION	QTY	PART NAME
E	 	2	BEAM (BACK)
E1	 	2	BEAM (BACK)
E2	 	2	BEAM (MEDDLE)





Parts List (BOX D)

PART NO	DESCRIPTION	QTY	PART NAME
AA	 M6*18	84+2	
BB	 M6*15	116+2	
CC	 M6*13	8	
DD	 M4*12	10	
EE	 M6*10	196+3	
FF	 M6	16	
GG	 M6*40	8	
HH	 M4*20	4	
II	 4mm  4mm  4mm	3	
JJ		1	
KK	 10mm	1	
NN	 M6*50	24	

Parts List (BOX E)

PART NO	DESCRIPTION	QTY	PART NAME
D		2	BEAM (MEDDLE)
D1		2	BEAM (MEDDLE)

Parts List (BOX F)

PART NO	DESCRIPTION	QTY	PART NAME
B		2	BEAM (LEFT)
B1		2	BEAM (LEFT)
C		2	BEAM (RIGHT)
C1		2	BEAM (RIGHT)

Parts List (BOX G)

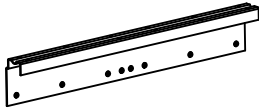
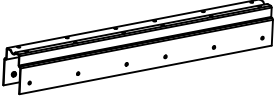
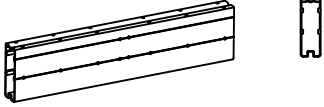

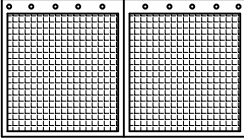
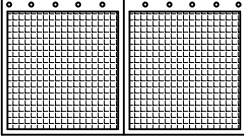
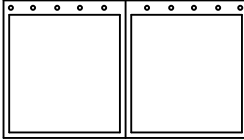
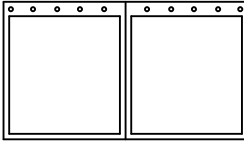

PART NO	DESCRIPTION	QTY	PART NAME
V		6	
W		2	
W1		1	

Parts List (BOX H)

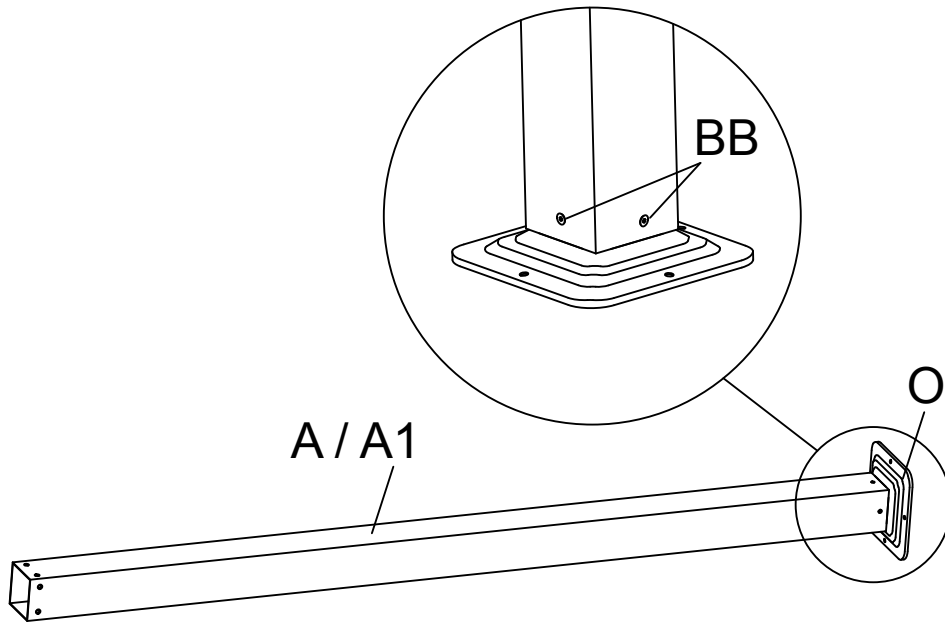
PART NO	DESCRIPTION	QTY	PART NAME
Y		4	NET
Y1		2	NET
Z		4	COVER
Z1		2	COVER

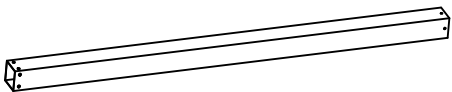
1

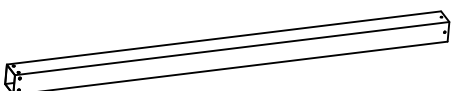

A	4		BB	24	 M6*15
A1	2		O	6	

2

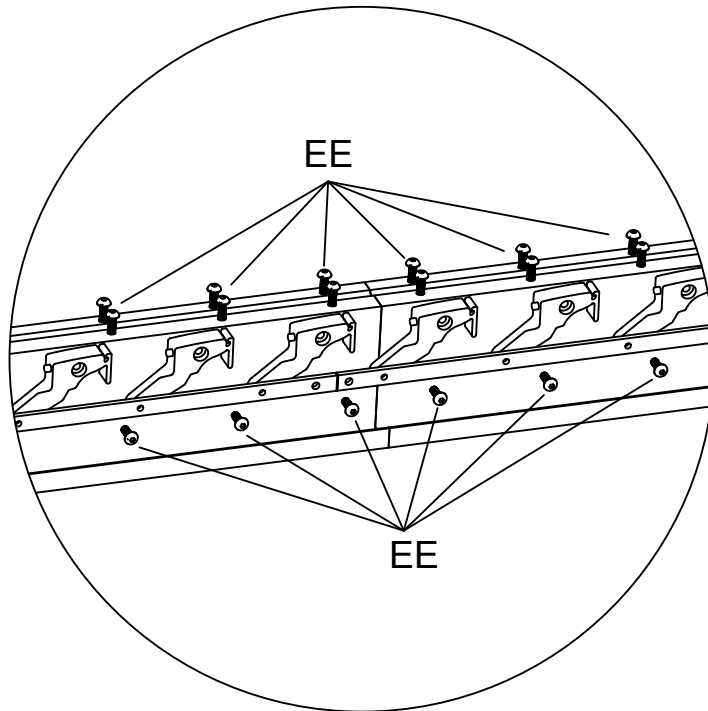
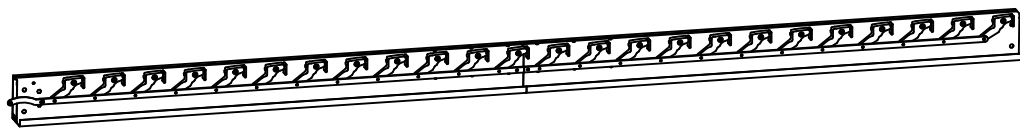
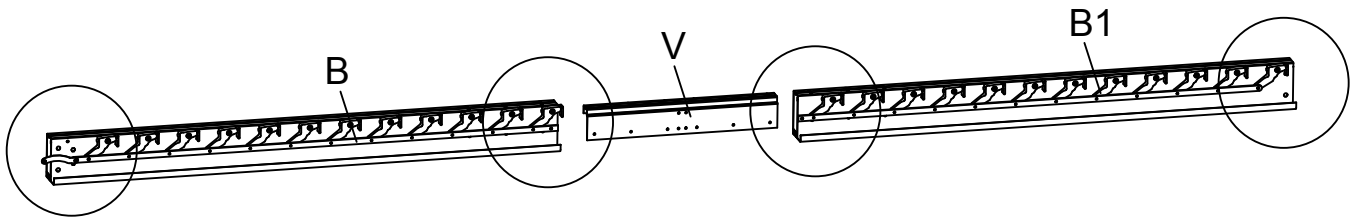
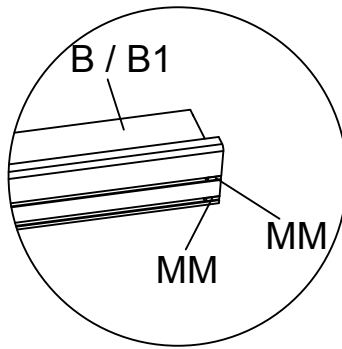
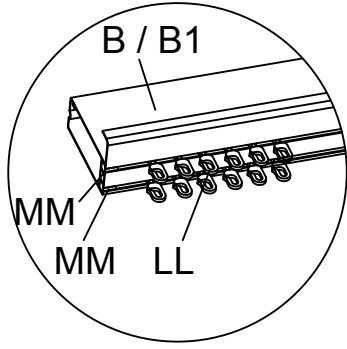

X2

B	2		V	2	
B1	2		EE	36	
LL	48		MM	16	

3

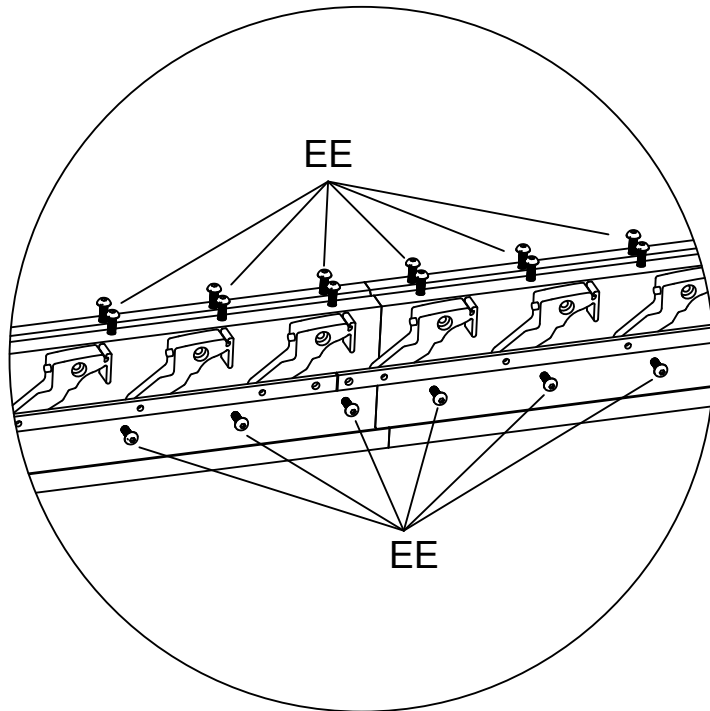
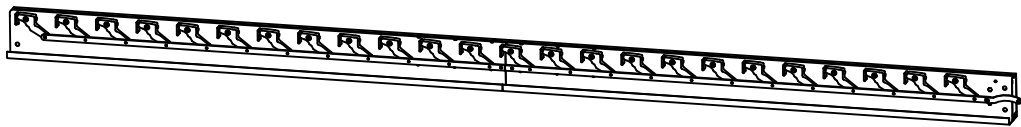
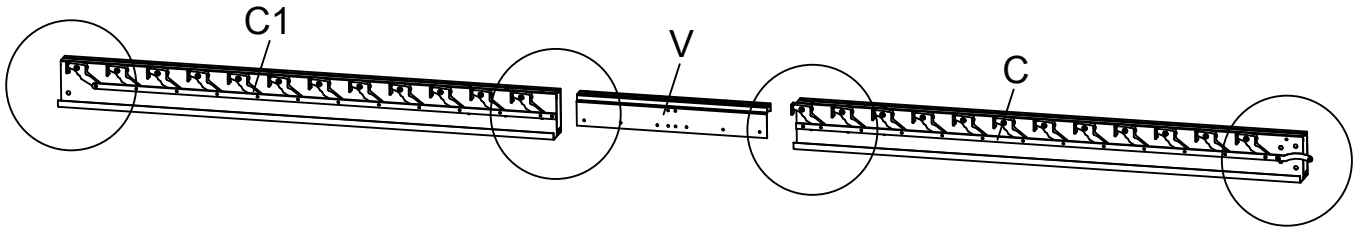
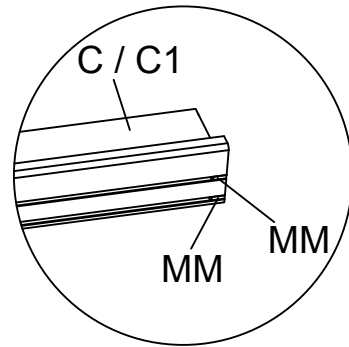
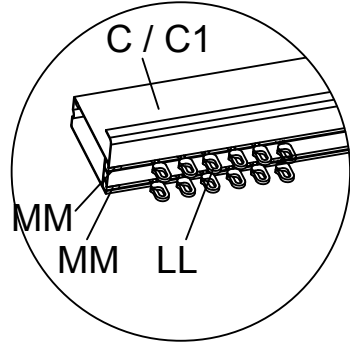

X2

C	2		V	2	
C1	2		EE	36	
LL	48		MM	16	

4

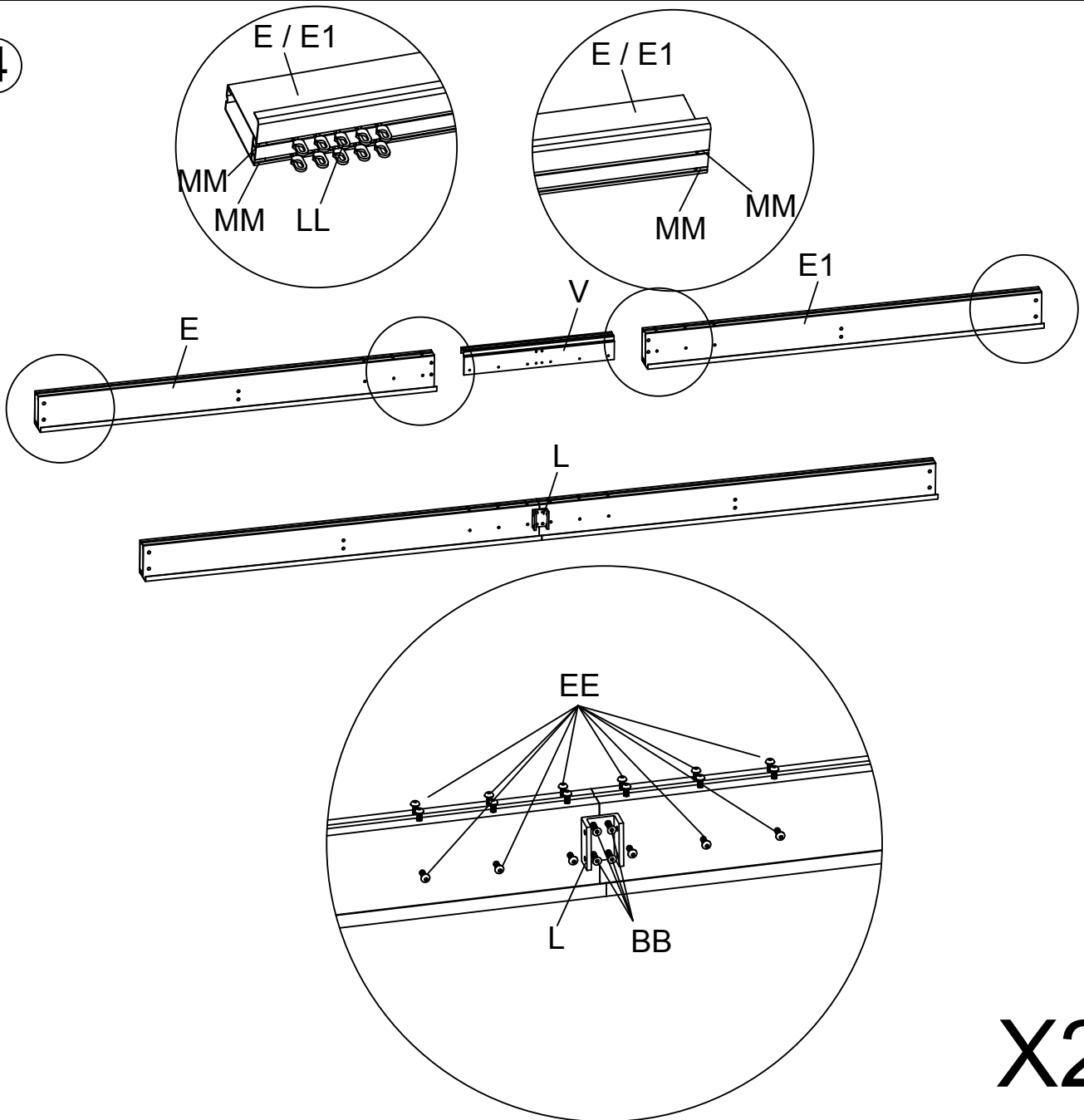



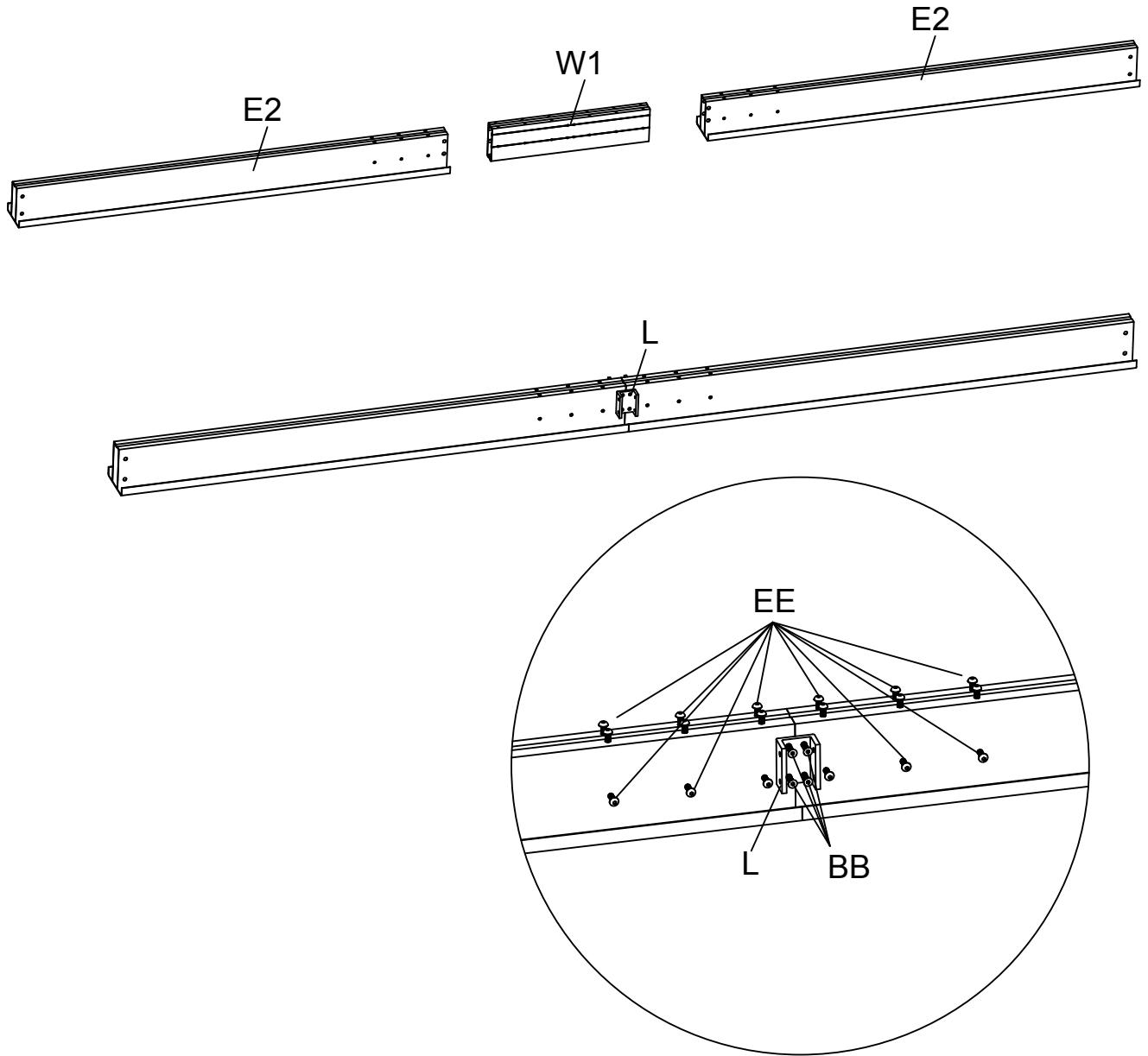

X2

E	2		V	2	
E1	2		BB	8	M6*15
L	2		EE	36	M6*10
LL	40		MM	16	

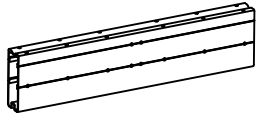
5



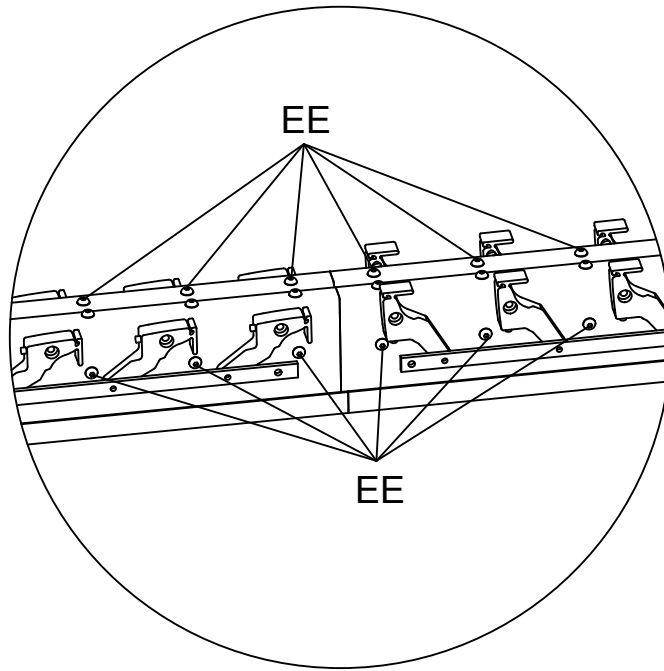
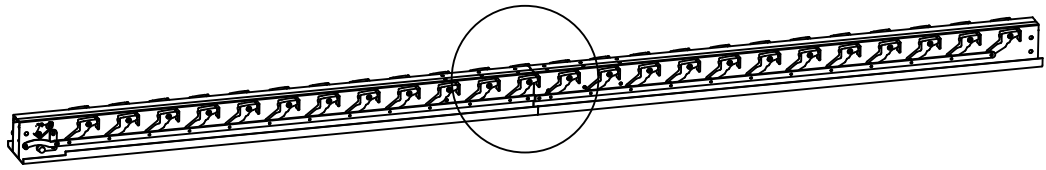
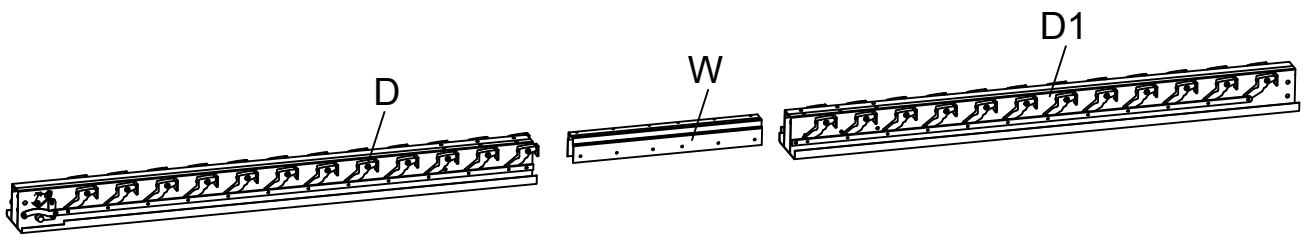

E2	2		W1	1	
L	2		BB	8	 M6*15
EE	24	 M6*10			

6



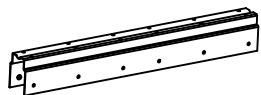



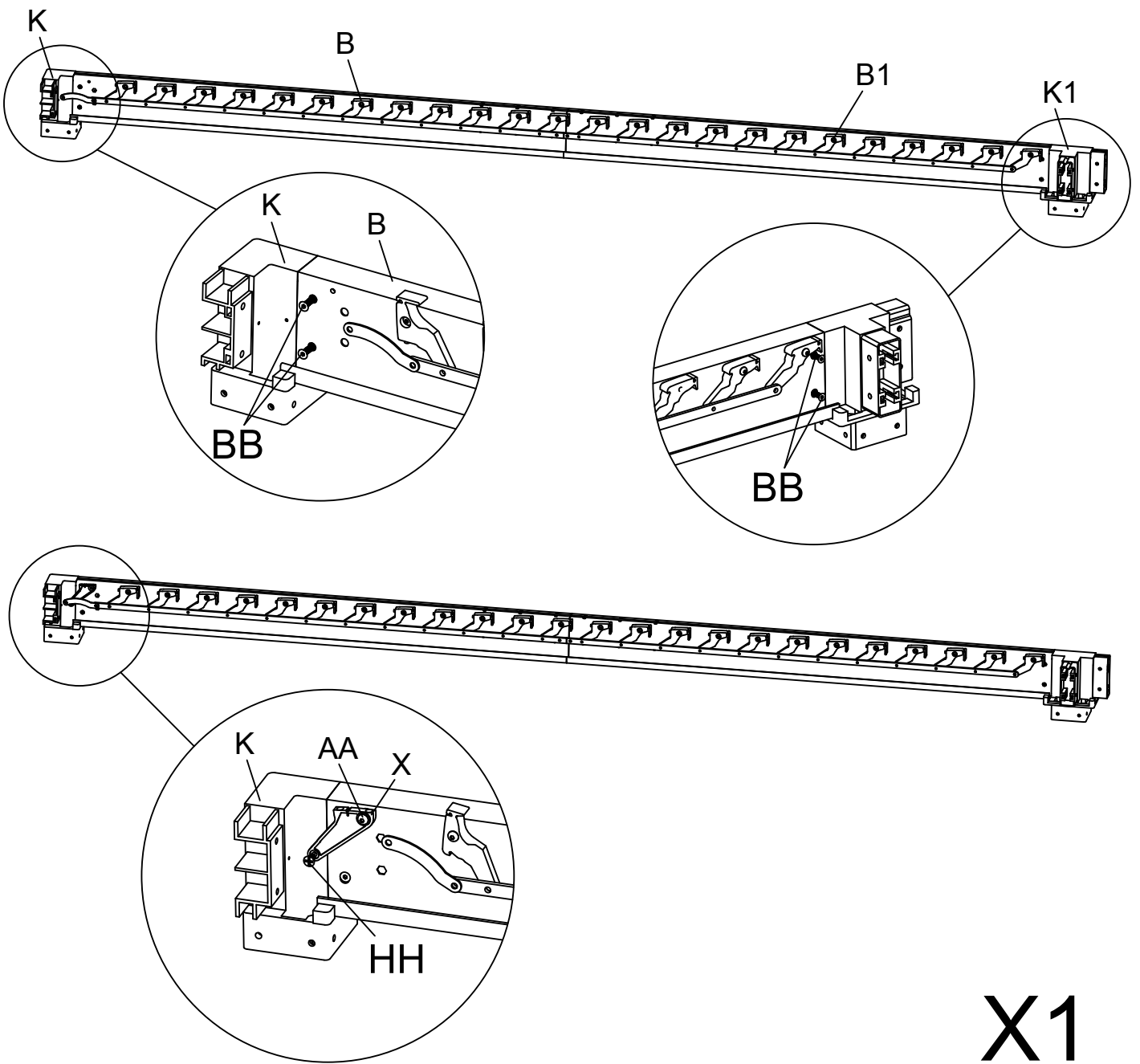

X2

D	2		W	2	
D1	2		EE	48	 M6*10

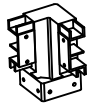
7

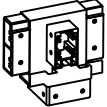

X1

K	1		AA	1	 M6*18
K1	1		BB	4	 M6*15
X	1		HH	1	 M4*20

8

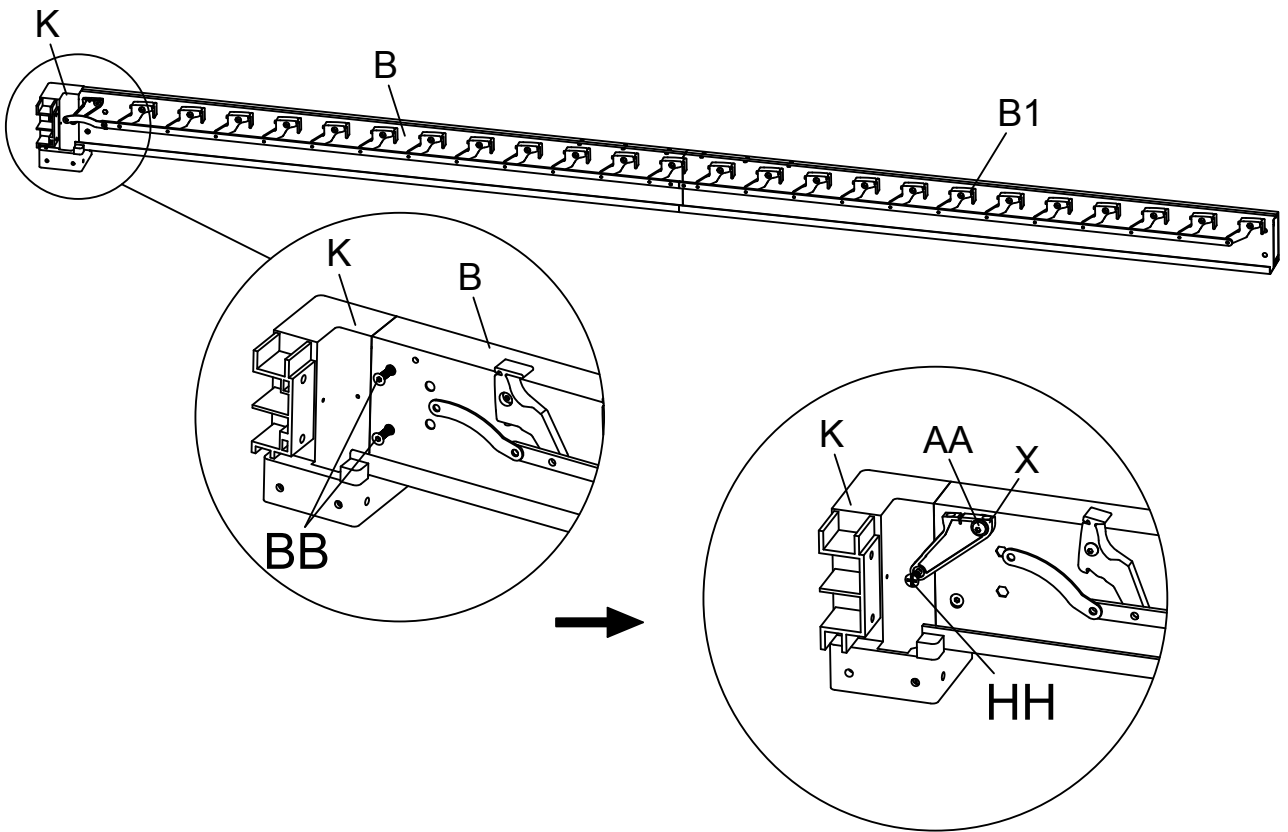

X1

K	1		AA	1		M6*18
X	1		BB	2		M6*15
			HH	1		M4*20

9

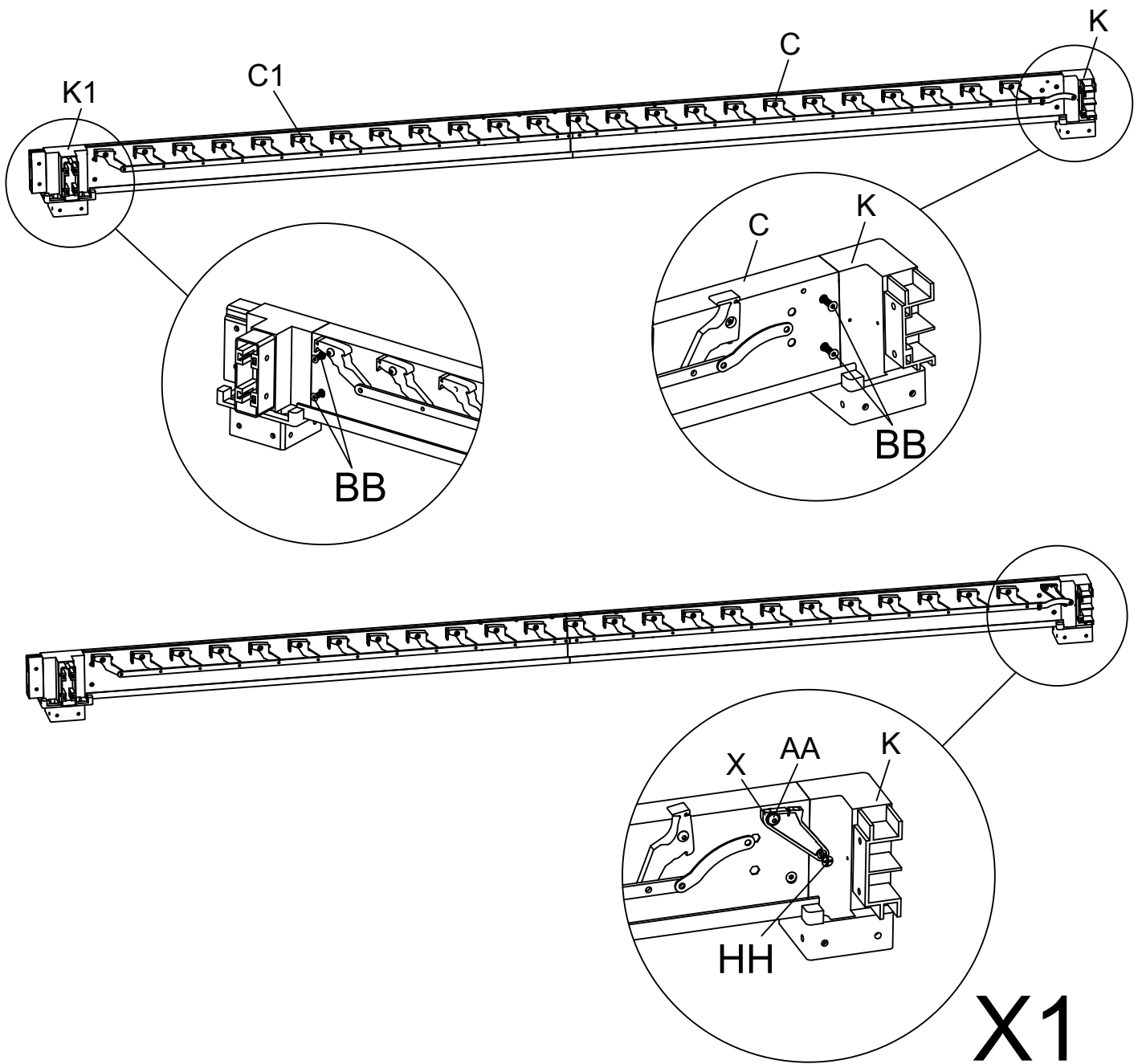



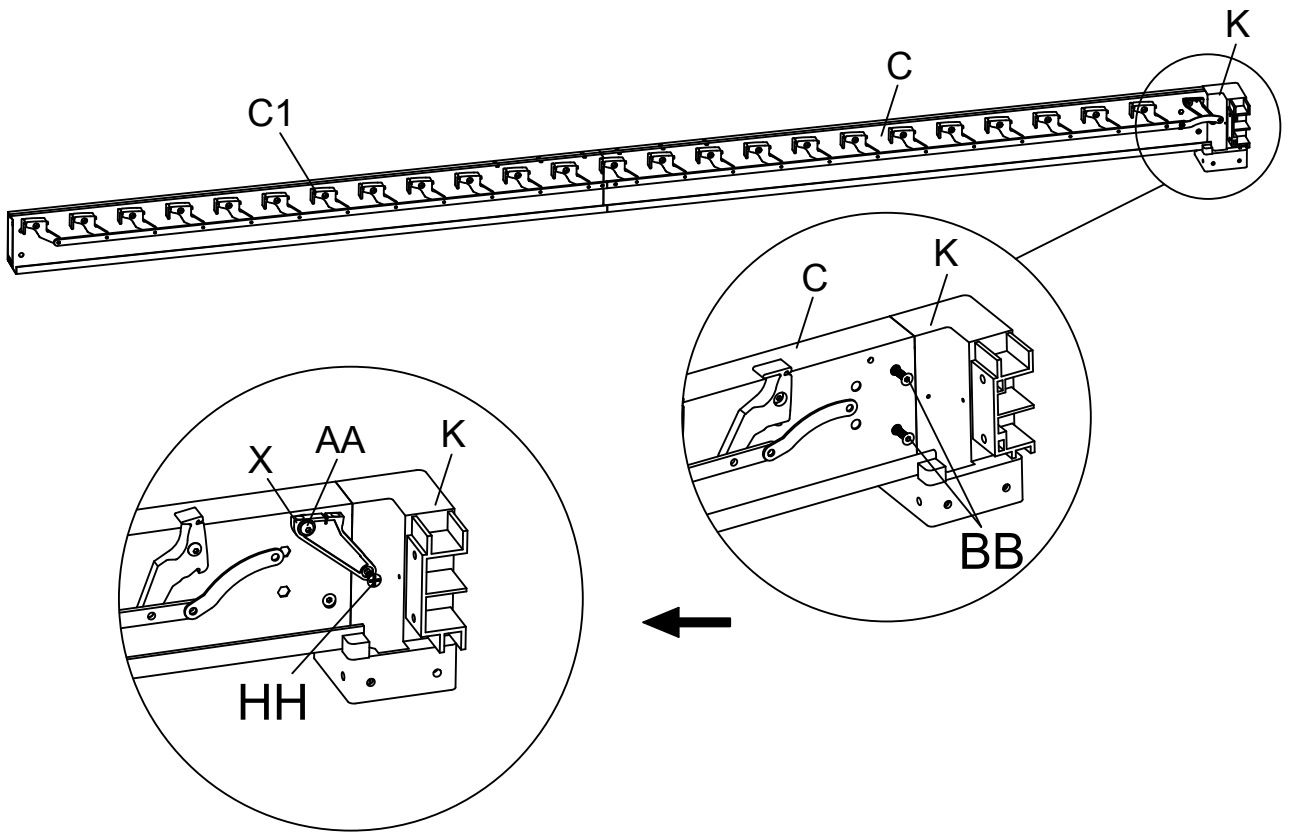

K	1		AA	1		M6*18
K1	1		BB	4		M6*15
X	1		HH	1		M4*20

10



X1

K	1		AA	1	 M6*18
X	1		BB	2	 M6*15
			HH	1	 M4*20

11

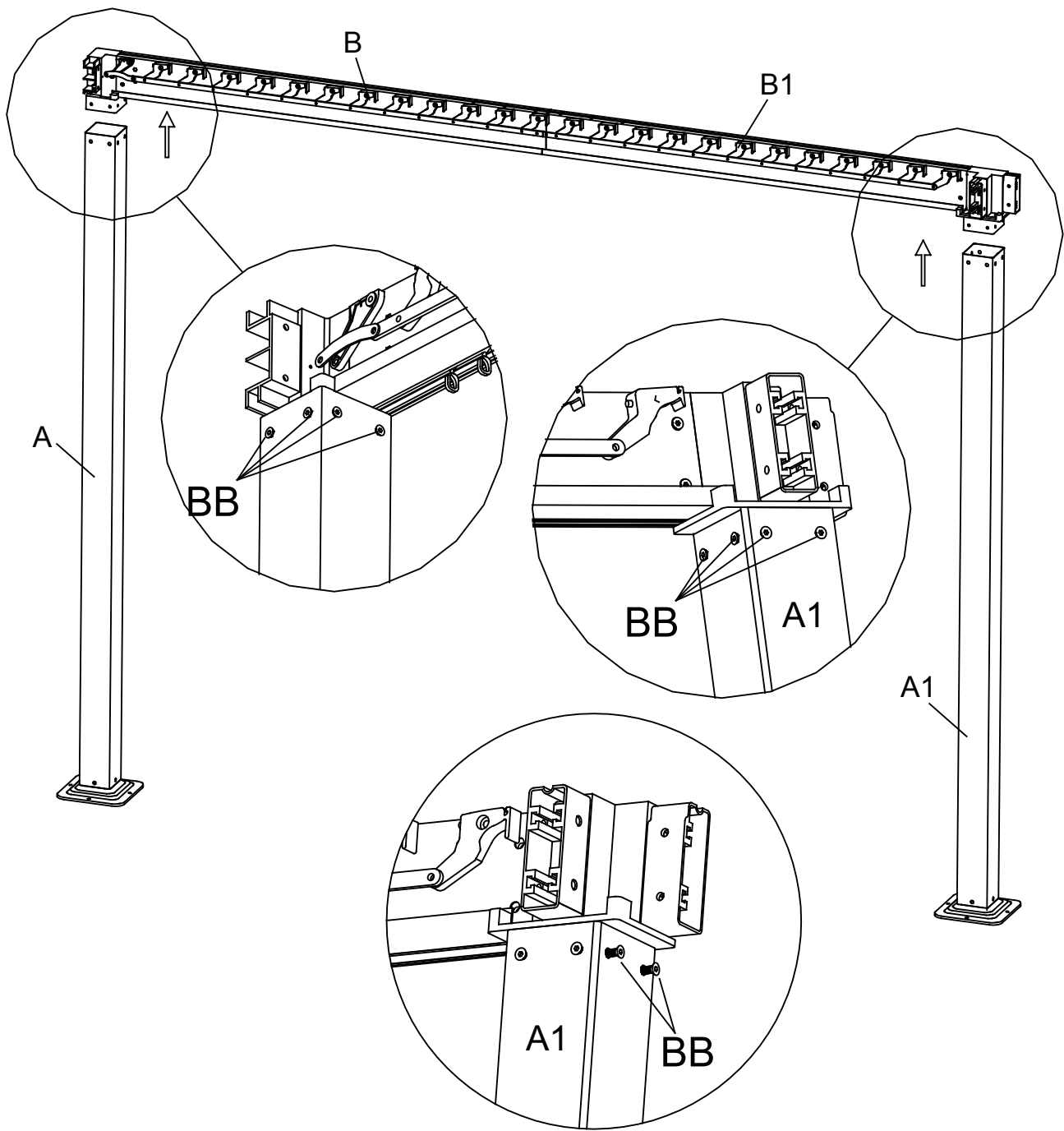

BB	10	 M6*15
----	----	---

12

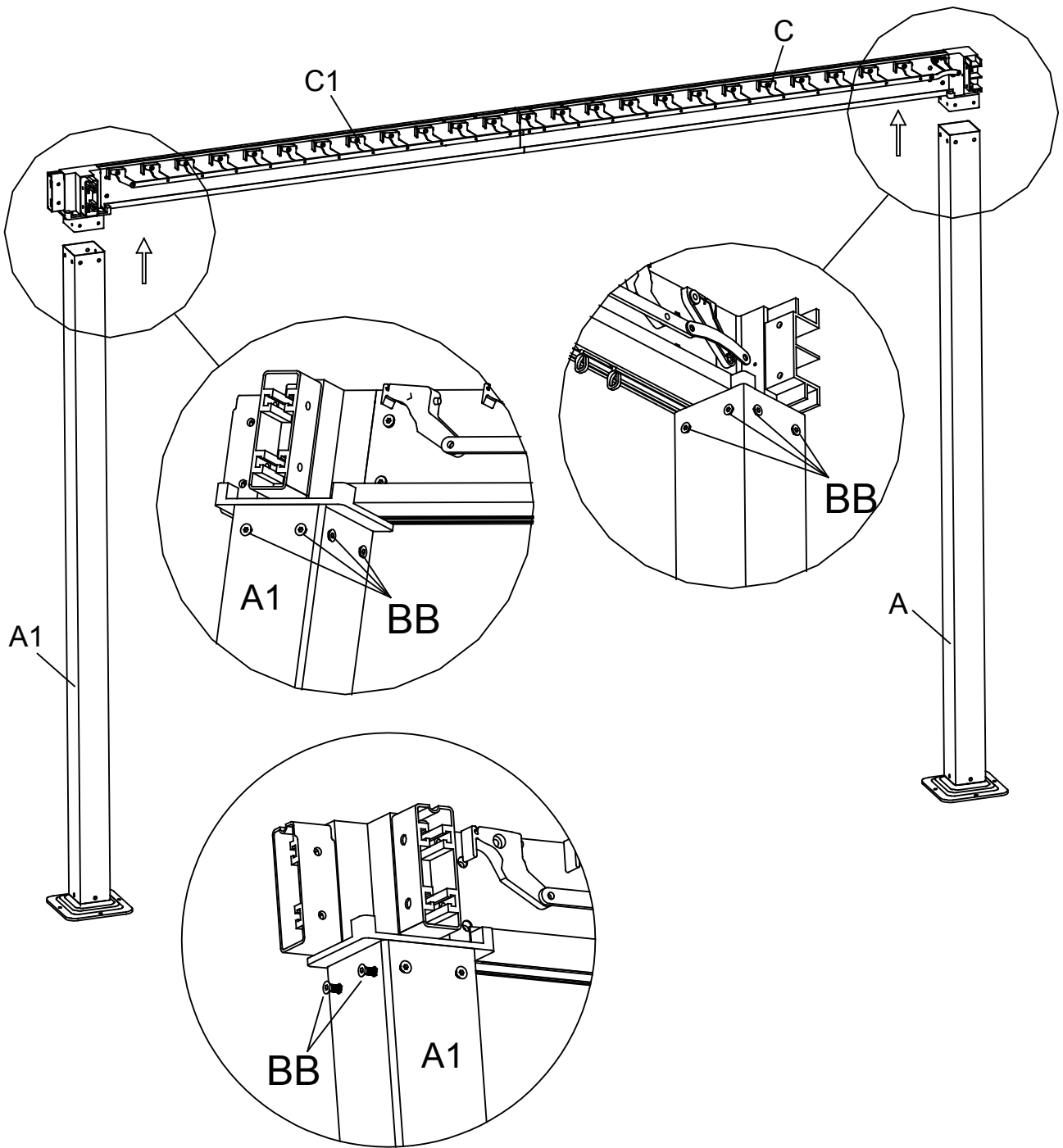

BB	10	 M6*15
----	----	---

13

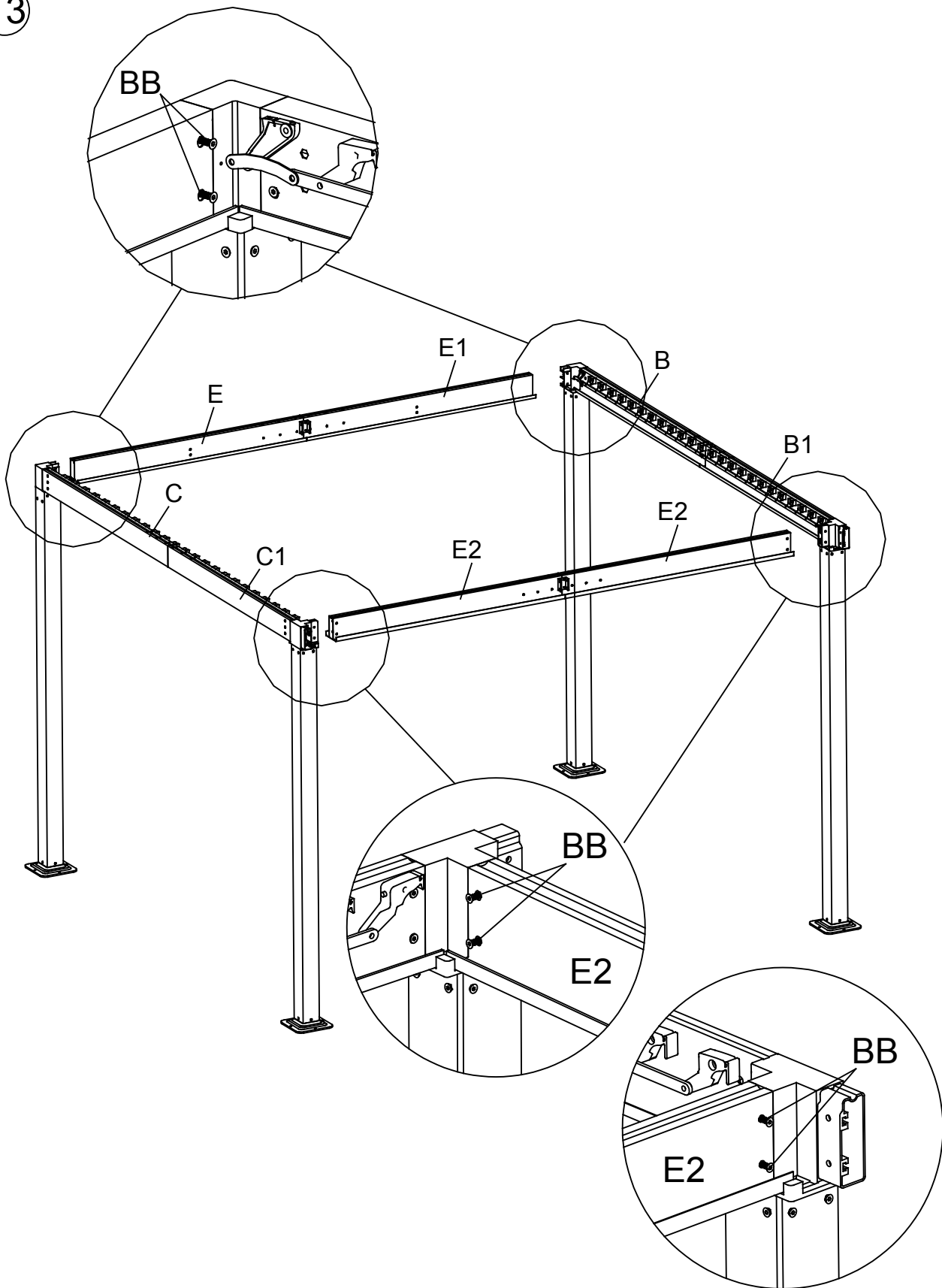

BB	12		M6*15
----	----	---	-------

14

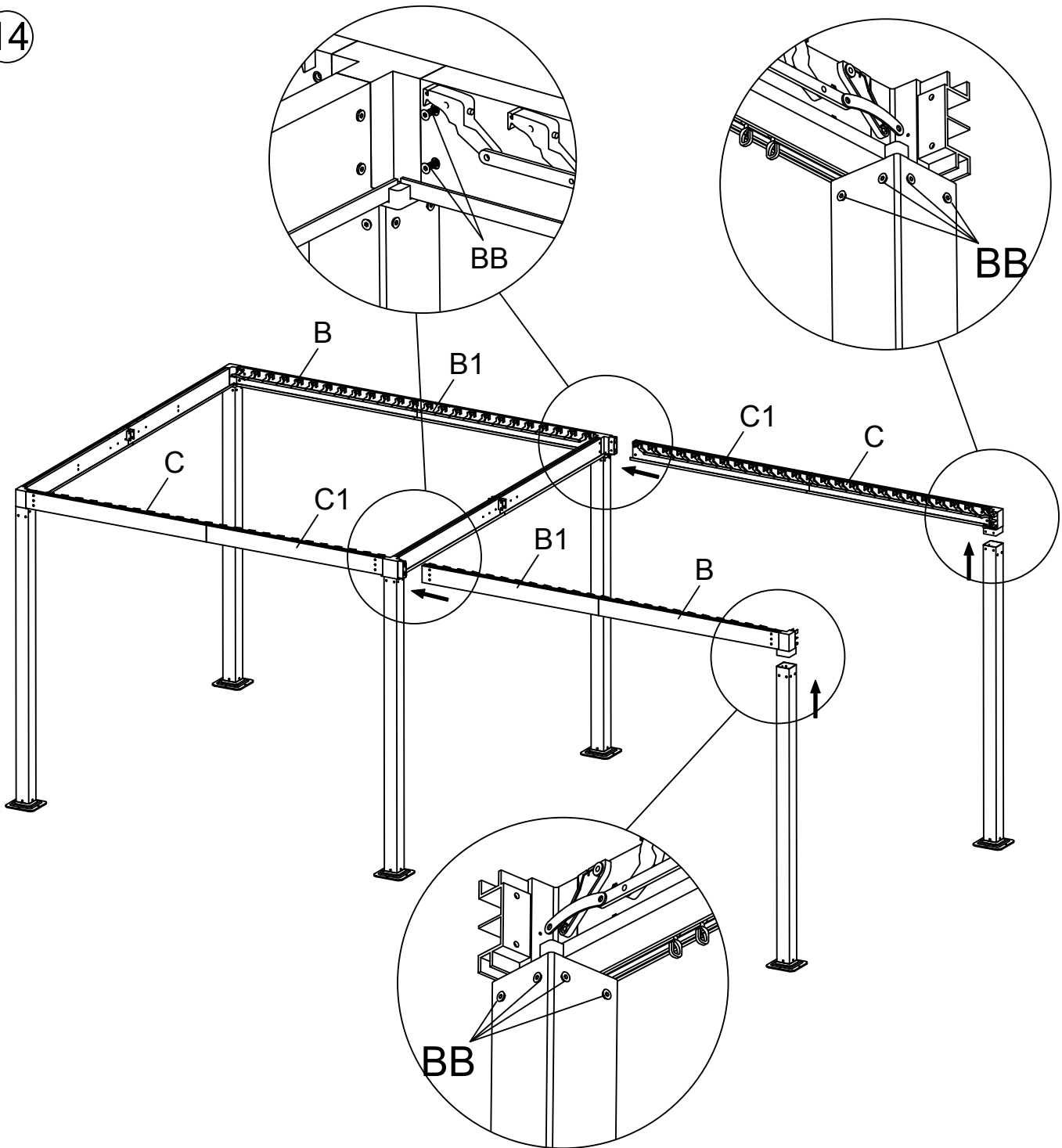

BB	12		M6*15
----	----	---	-------

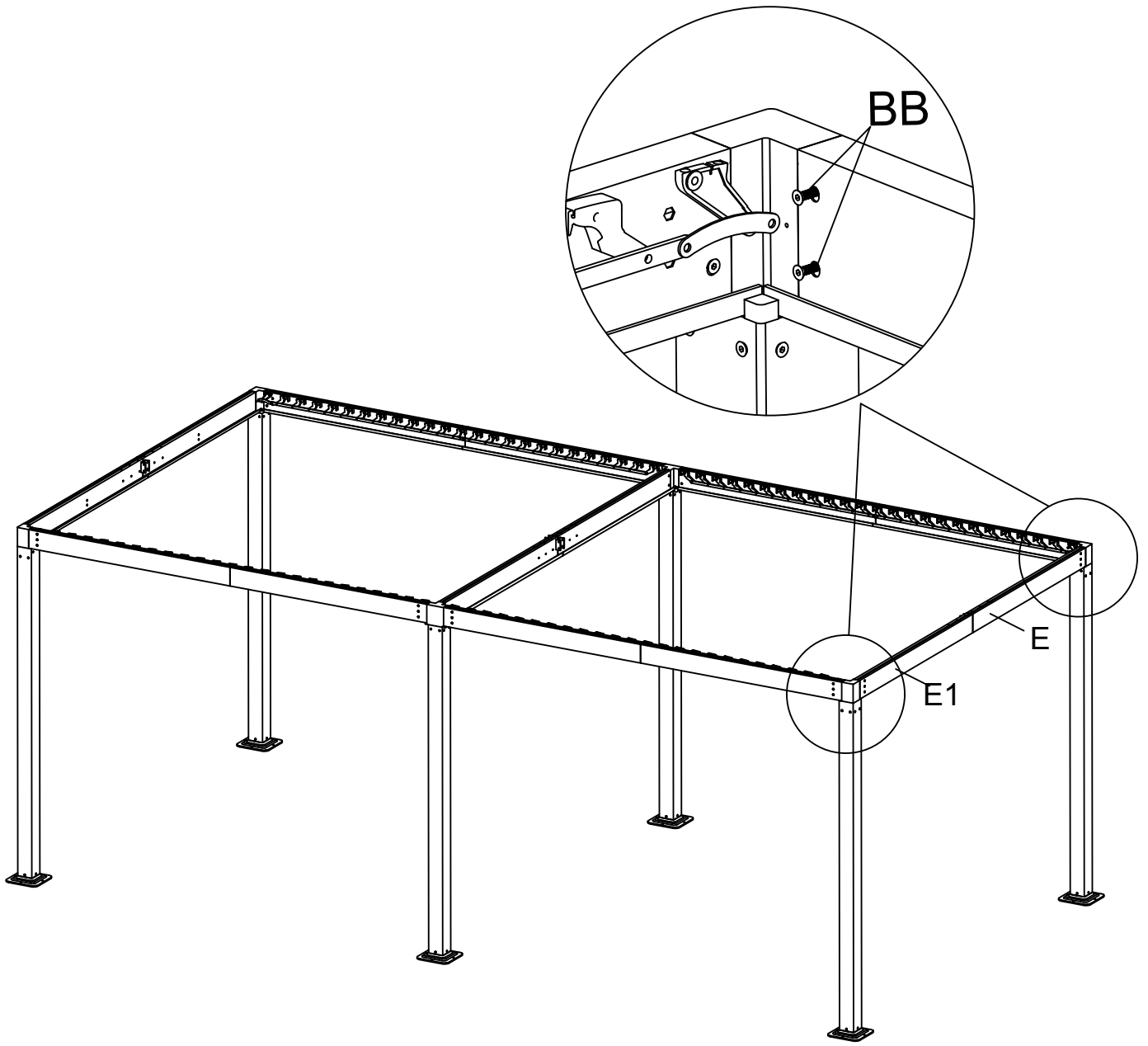

15



BB	4	 M6*15
----	---	---

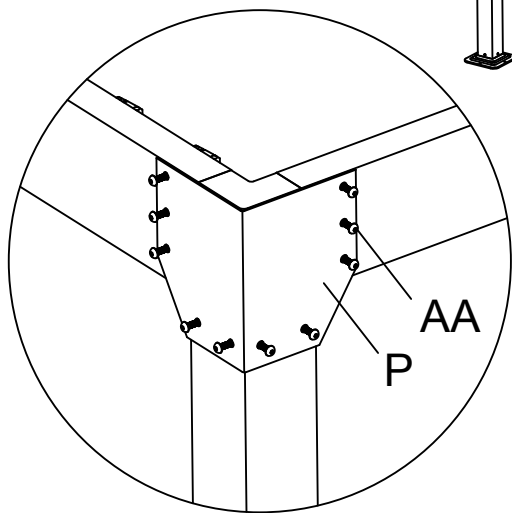
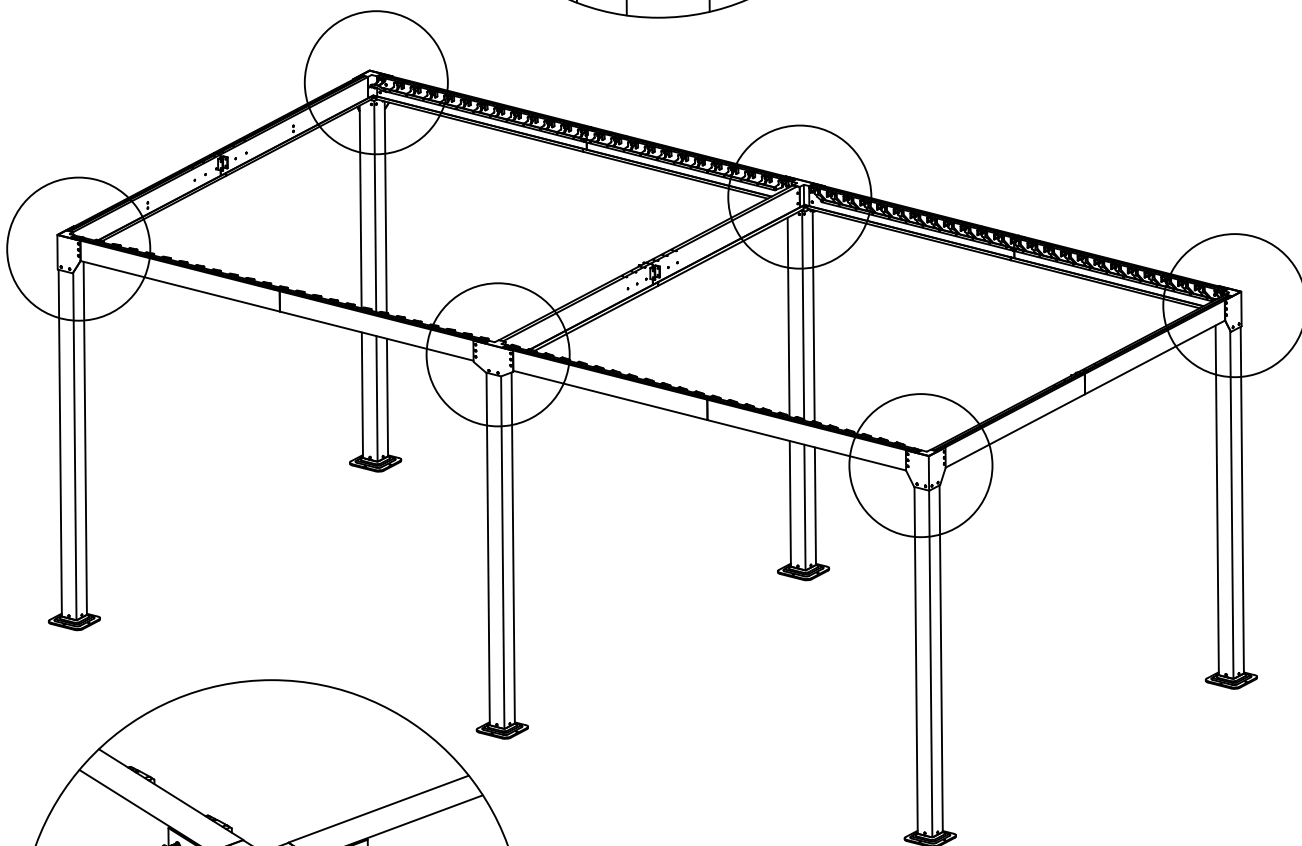
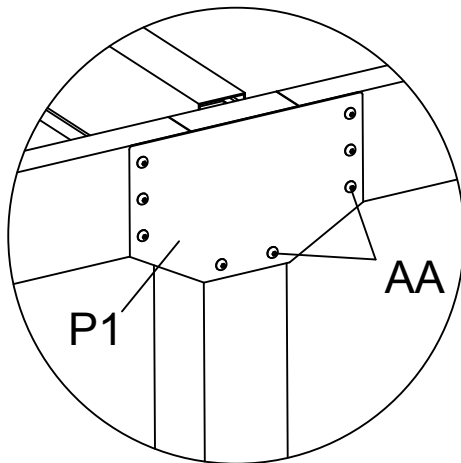

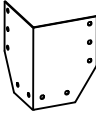
16

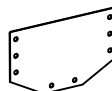

P	4		AA	56	 M6*18
P1	2				

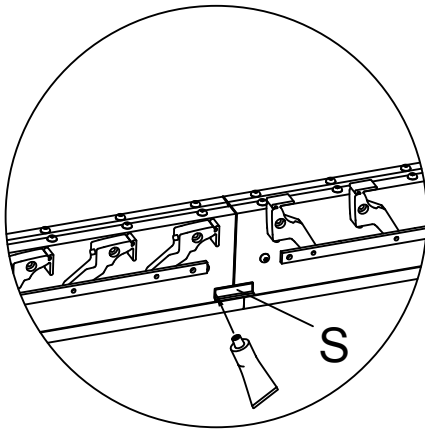
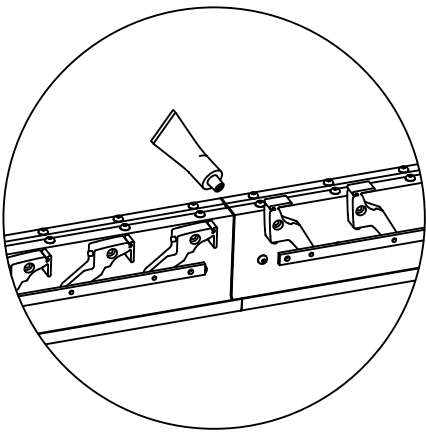
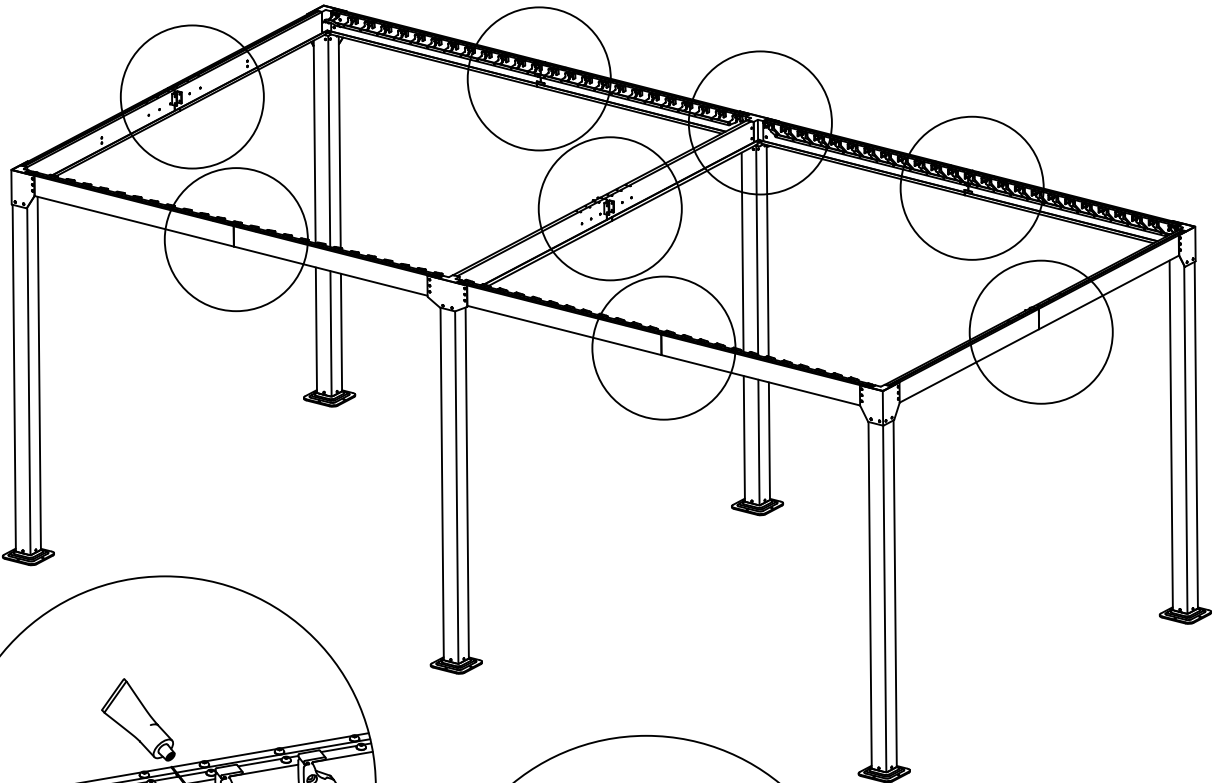
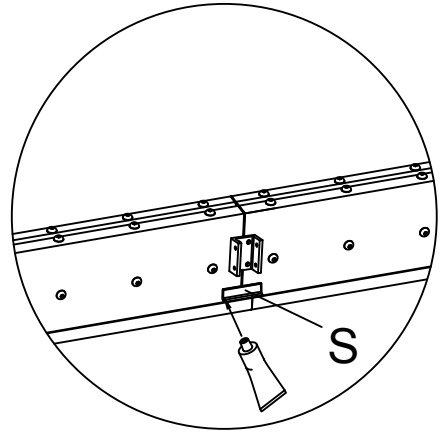
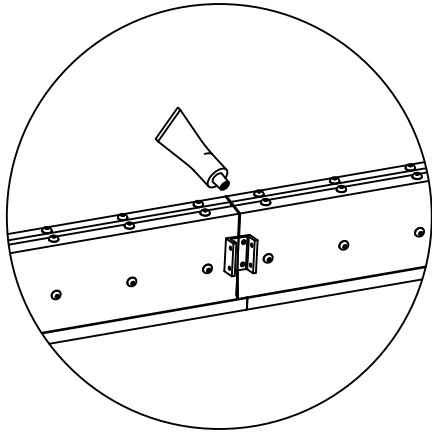
17



S	8		PP	1	
---	---	---	----	---	---

18

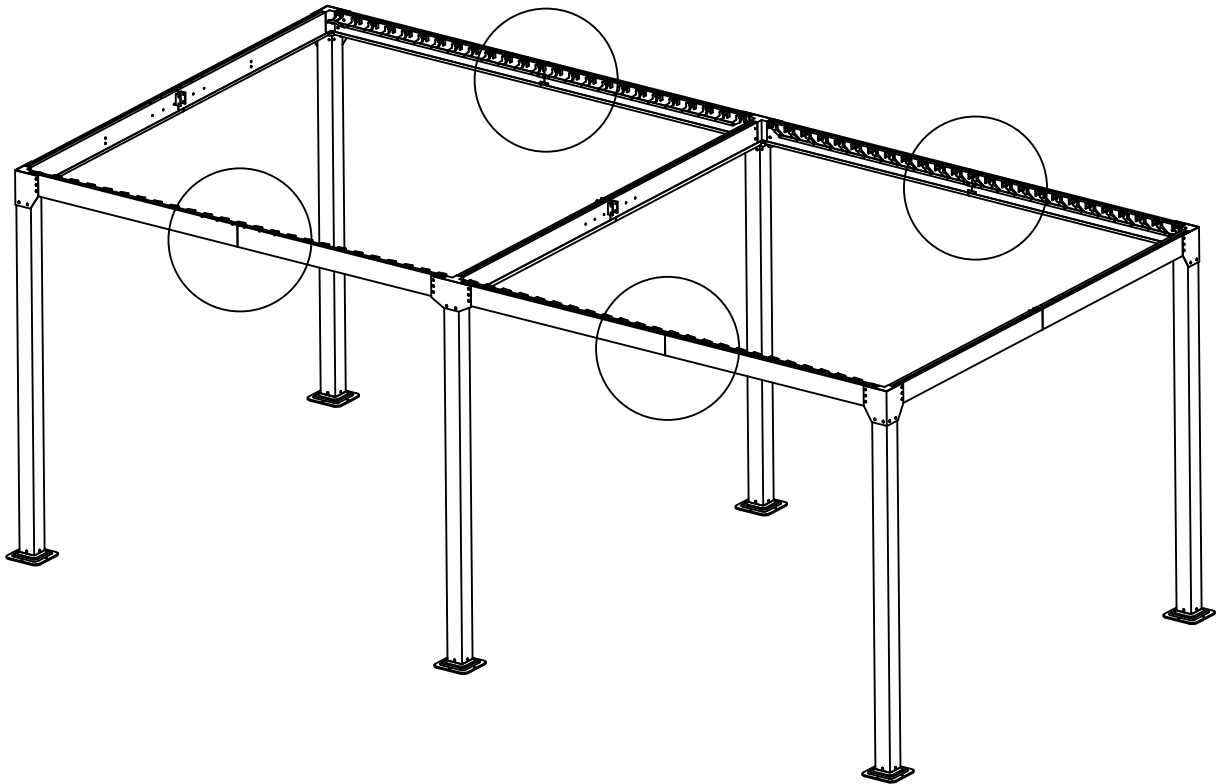
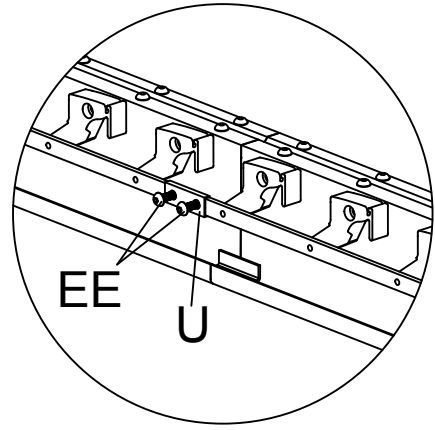



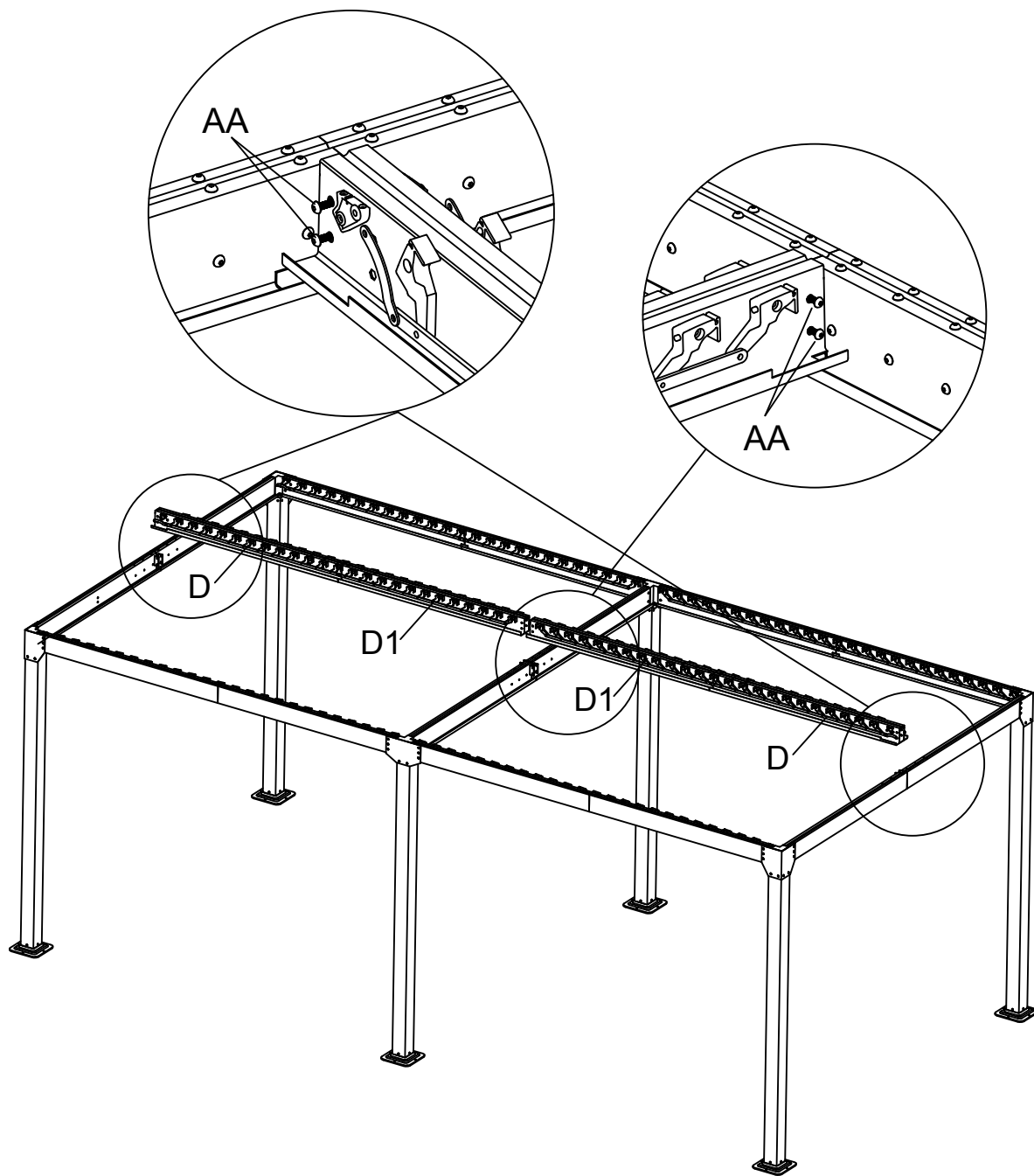

U	4		EE	8	 M6*10
---	---	---	----	---	---

19

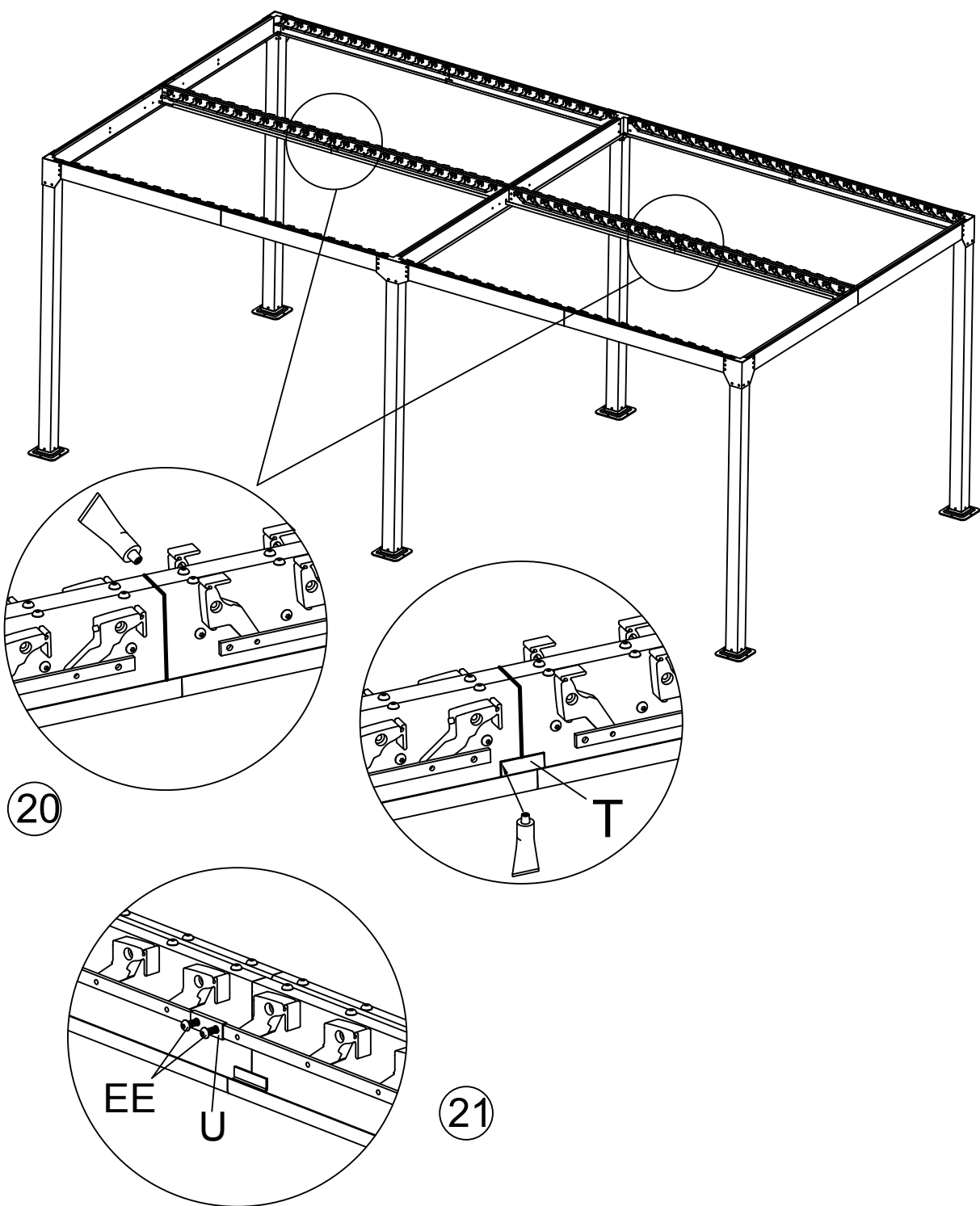



AA	16	 M6*18
----	----	---

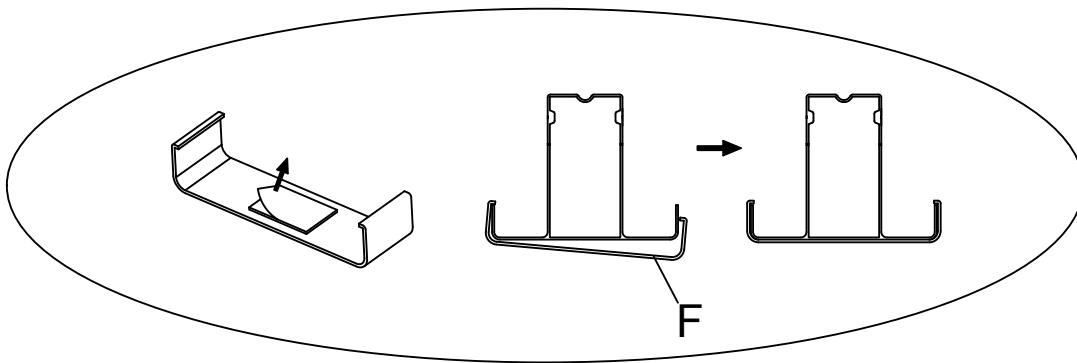
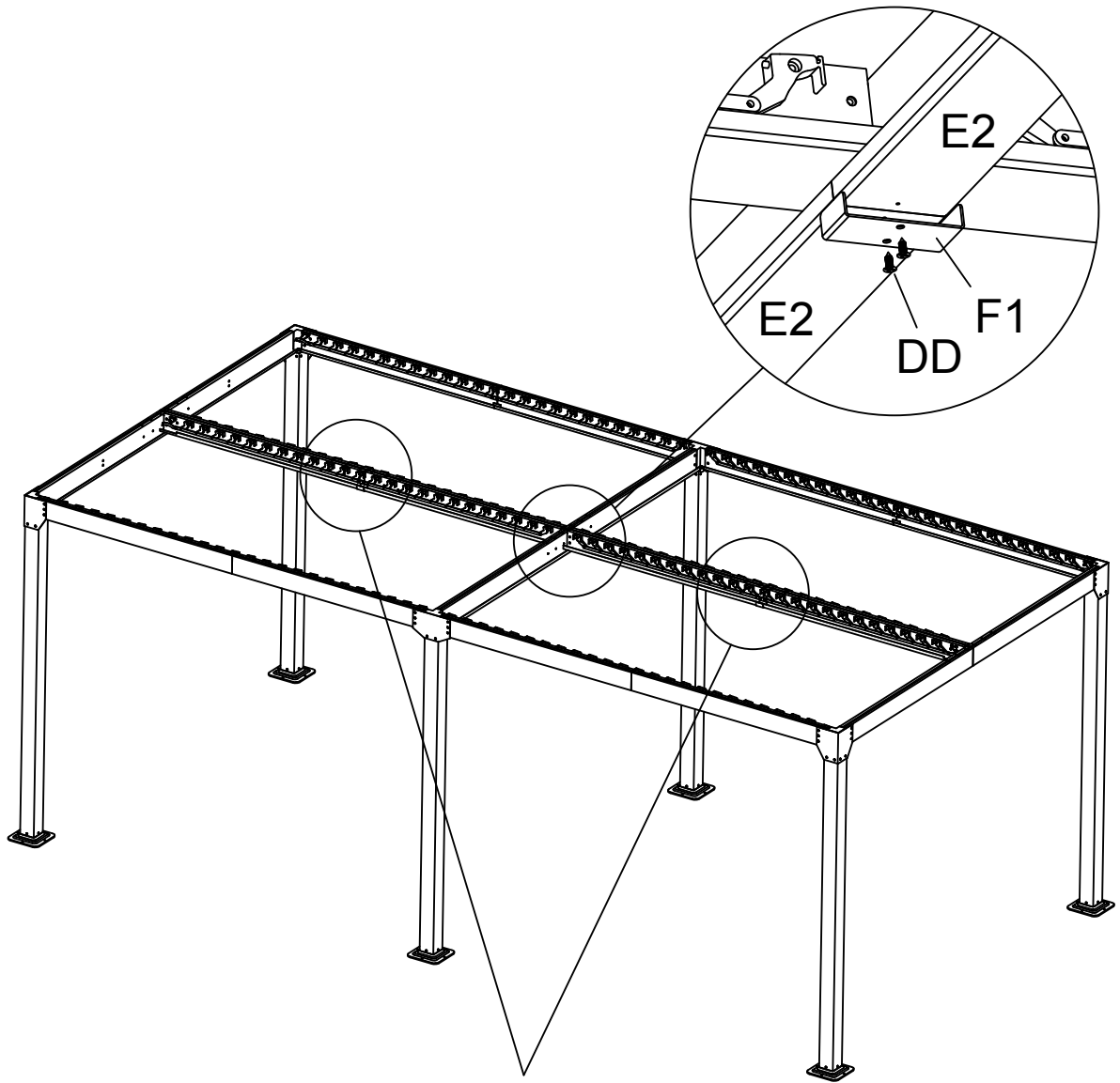

T	4		PP	1	
U	4		EE	8	 M6*10

22

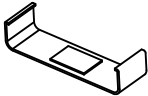

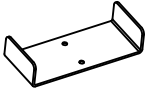
F	2		DD	2	 M4*12
F1	1				

23

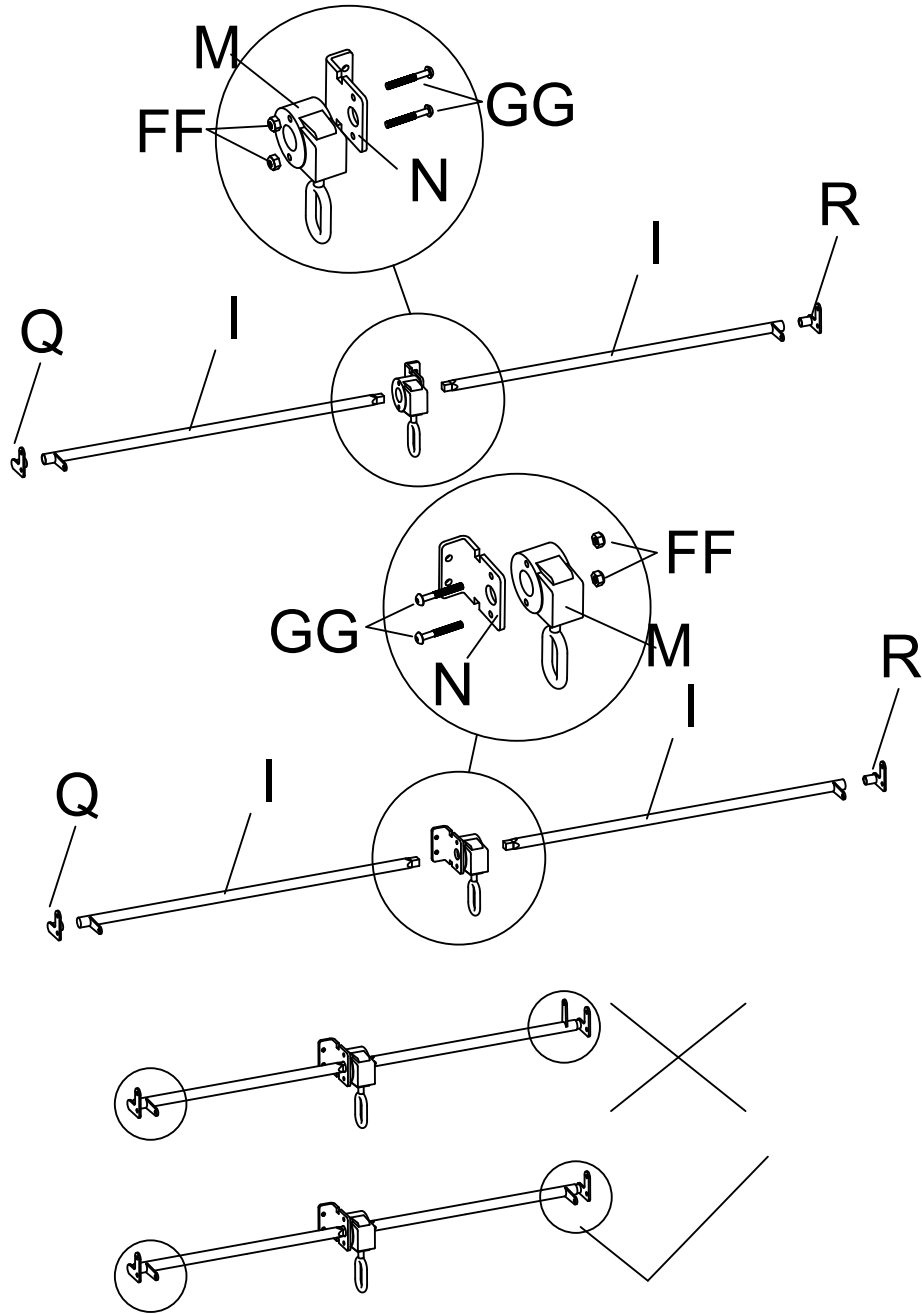

X2

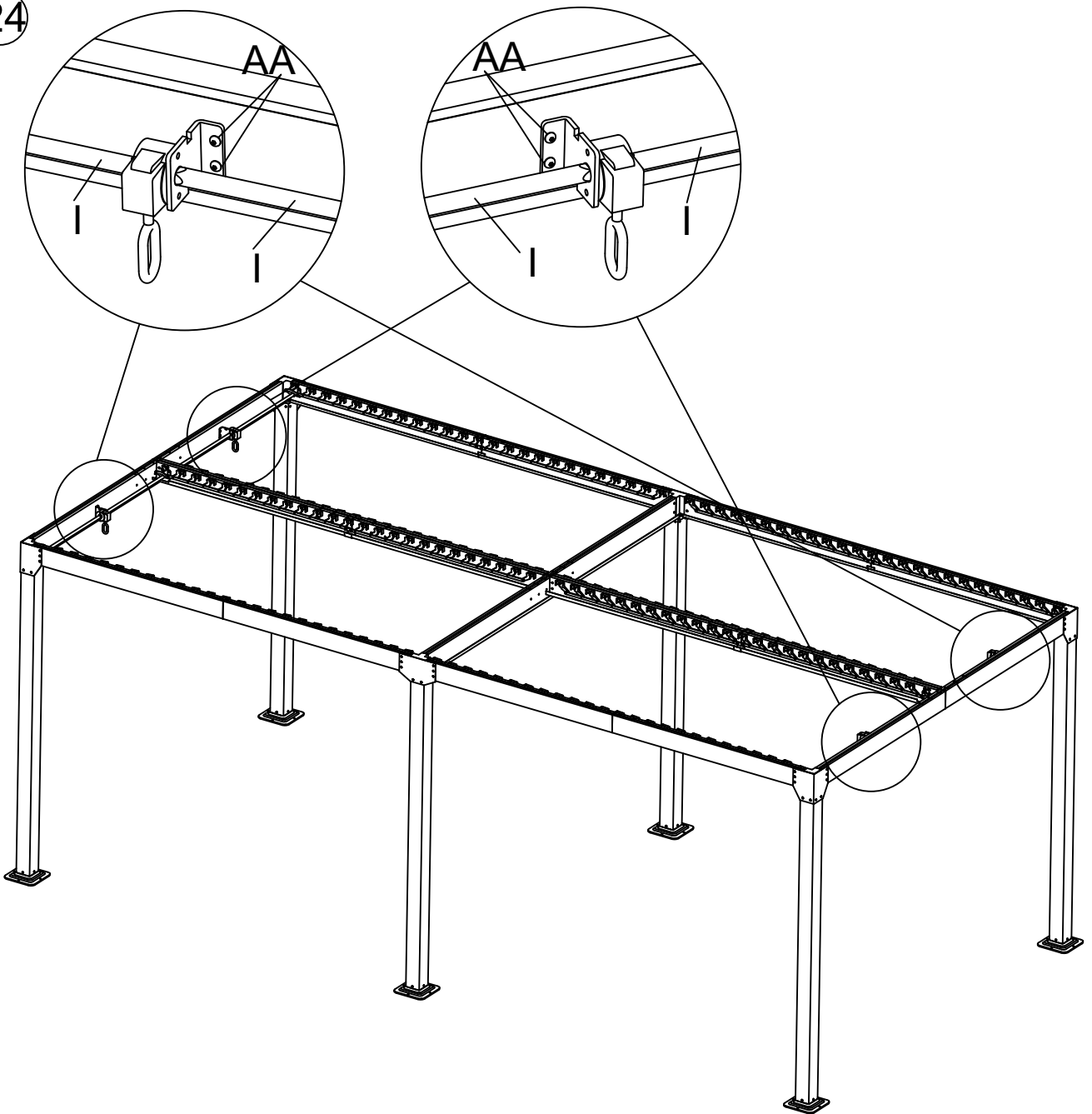

I	8		M	4	
Q	4		N	4	
R	4		GG	8	
FF	8				

24

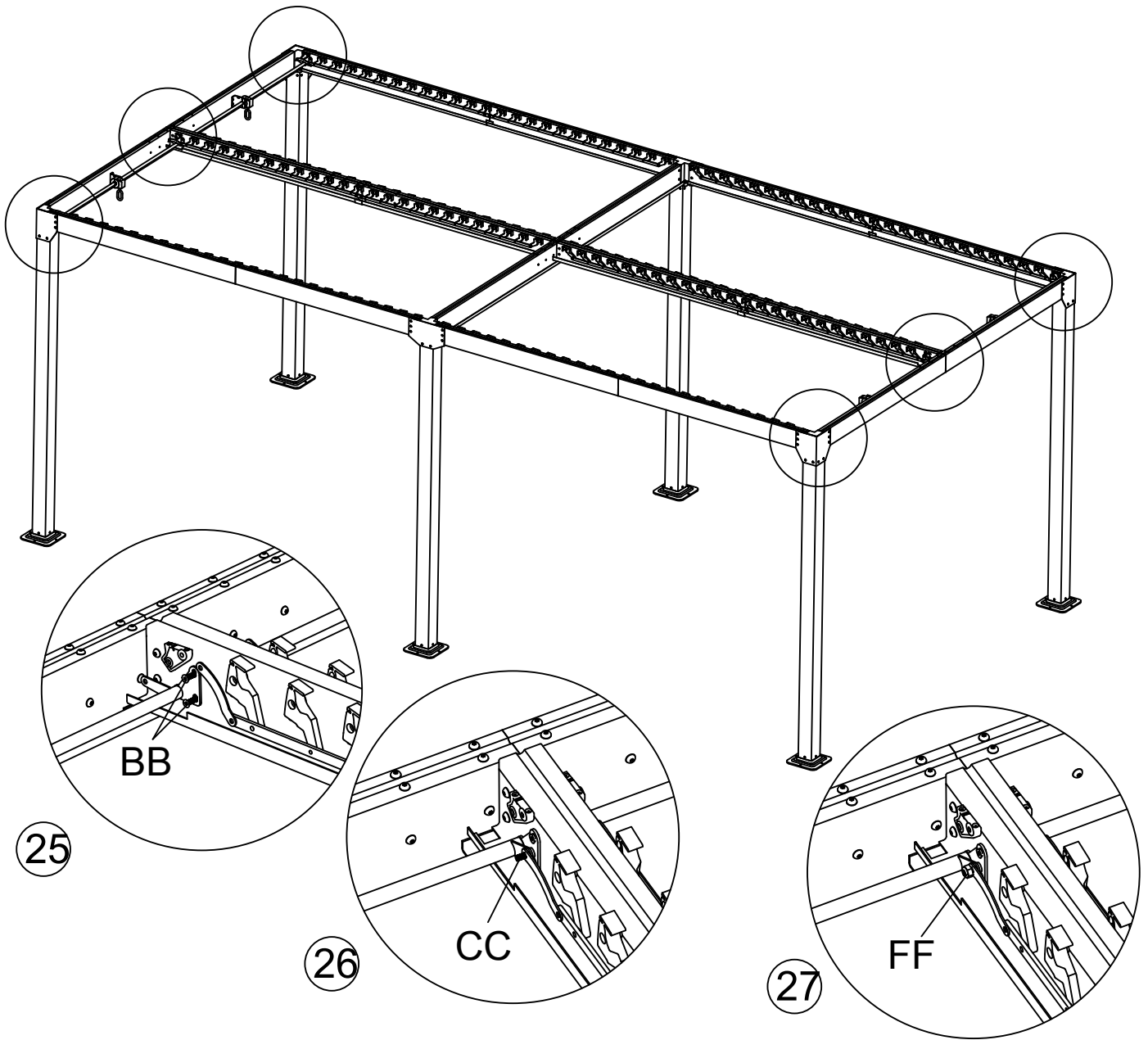

AA	8	 M6*18
----	---	---



BB	16	 M6*15	FF	8	 M6
CC	8	 M6*13			

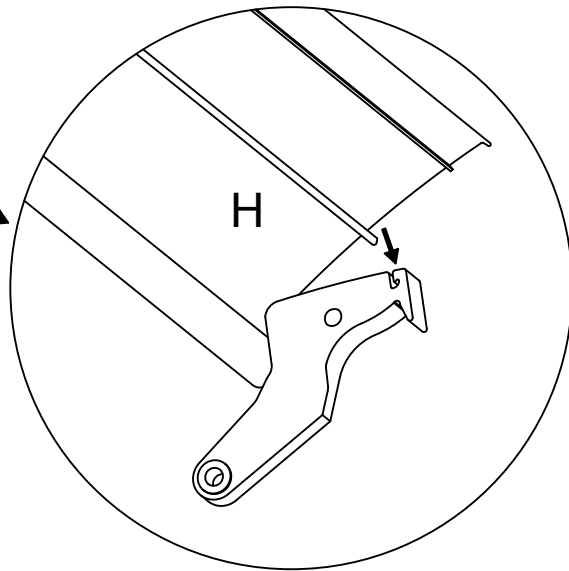
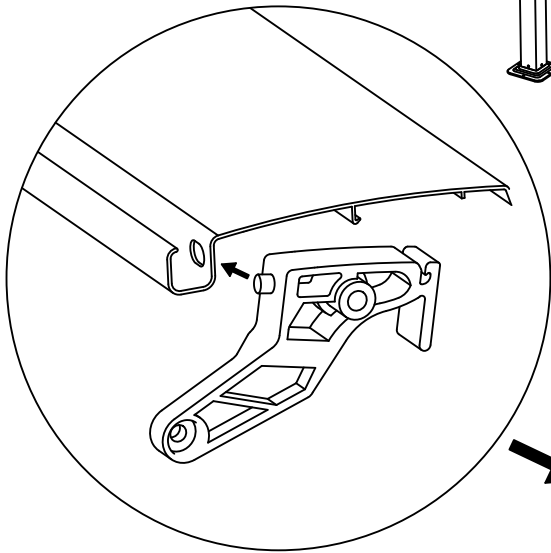
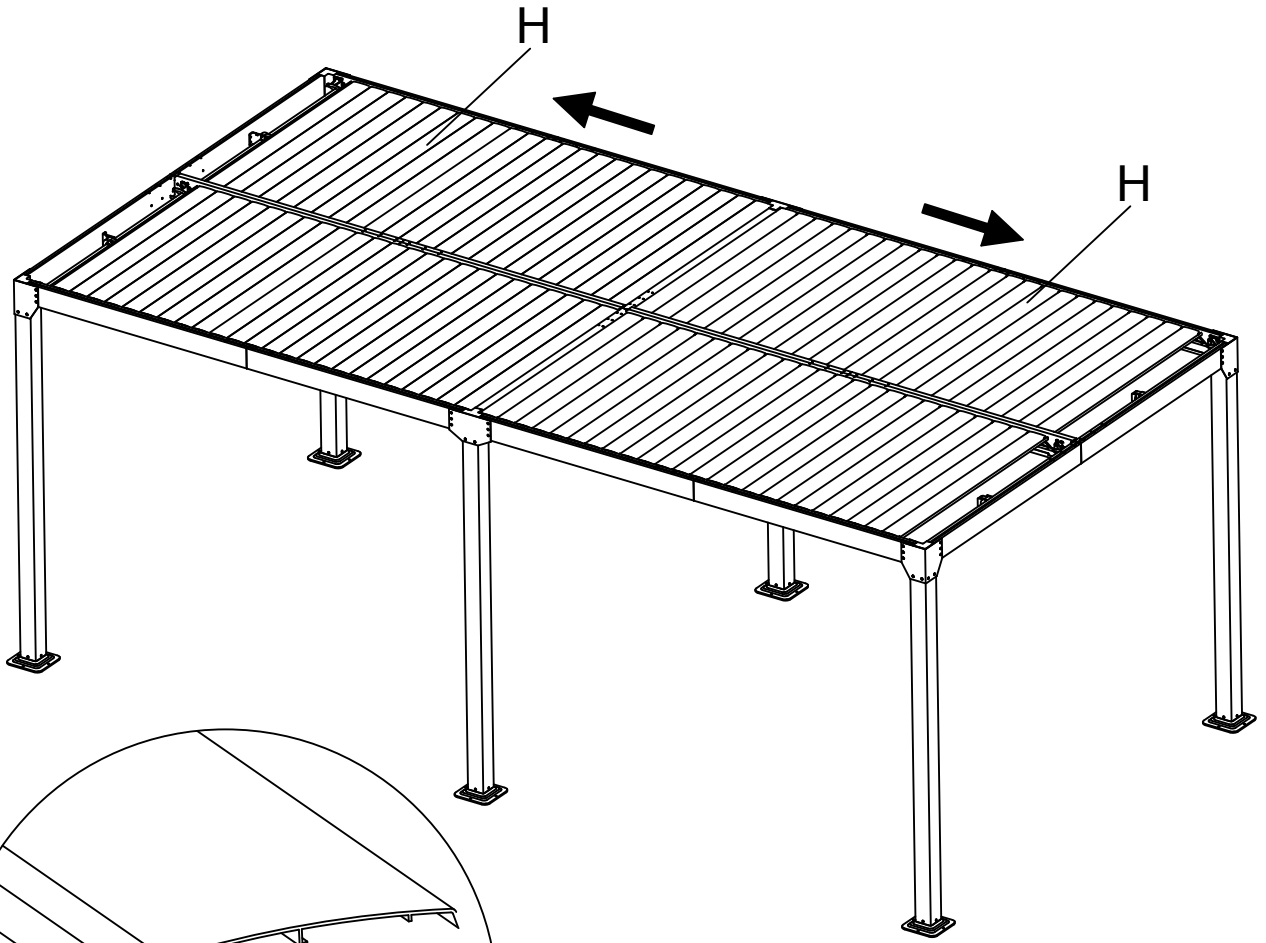

28

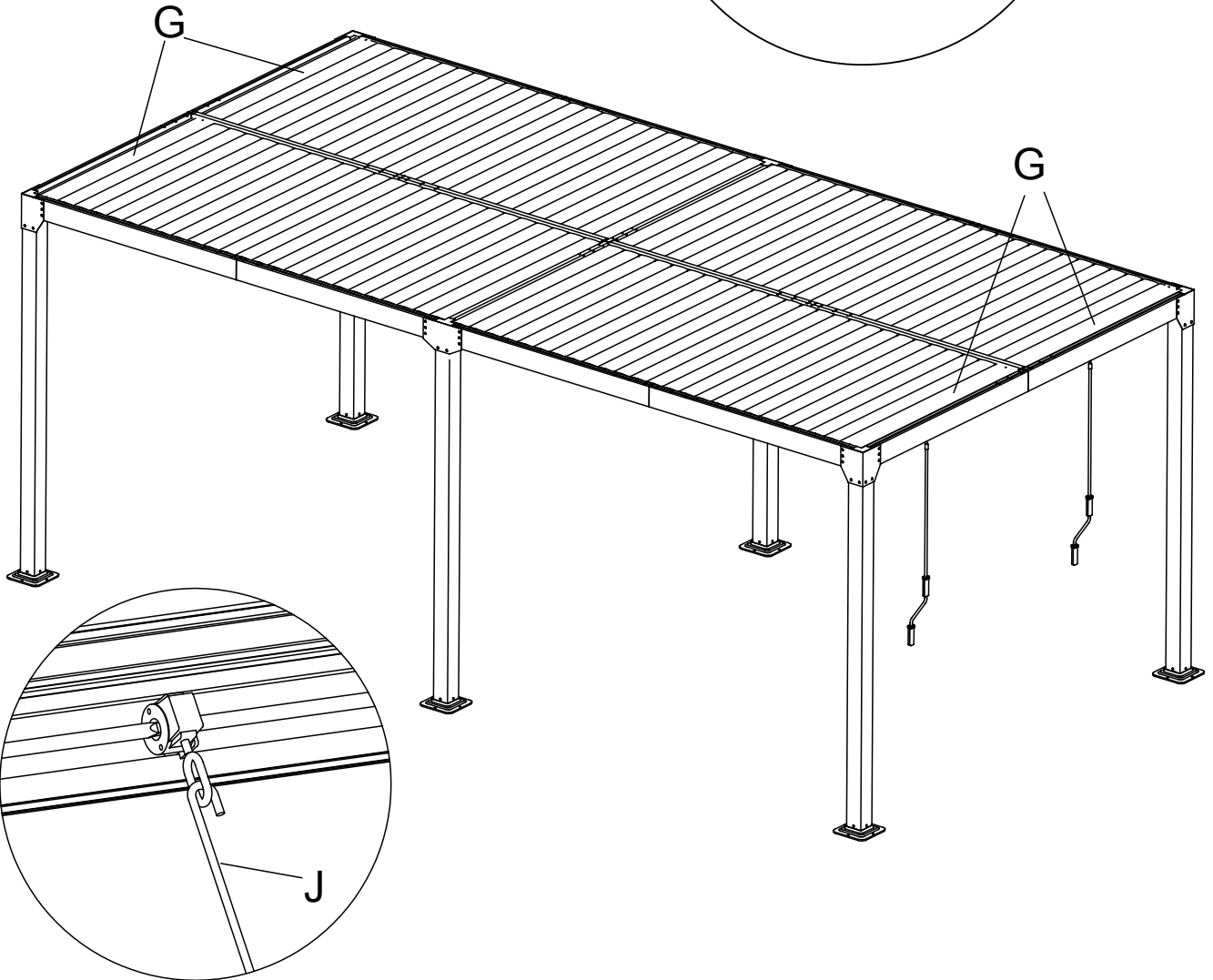
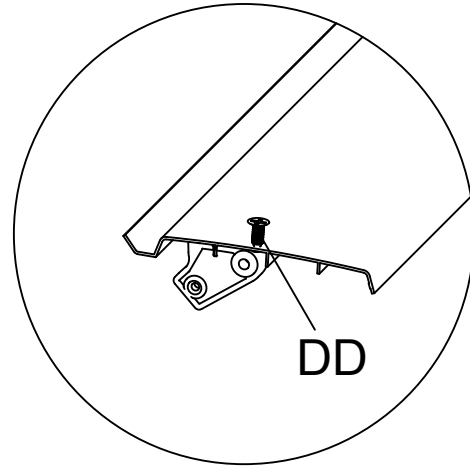

H	120	
---	-----	--

29

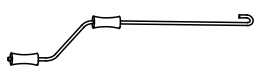

G	4		DD	8	 M4*12
J	2				

30

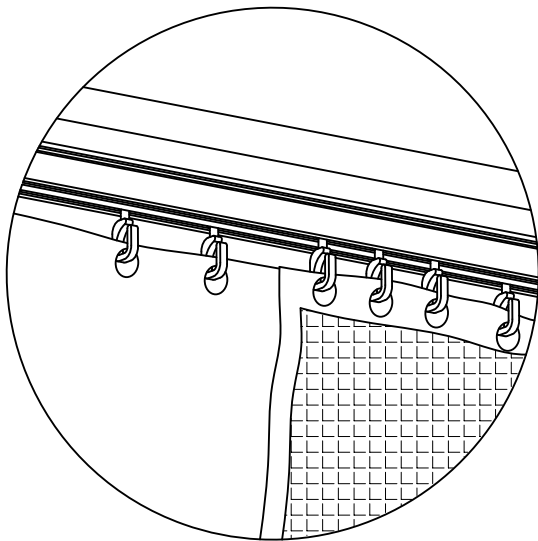
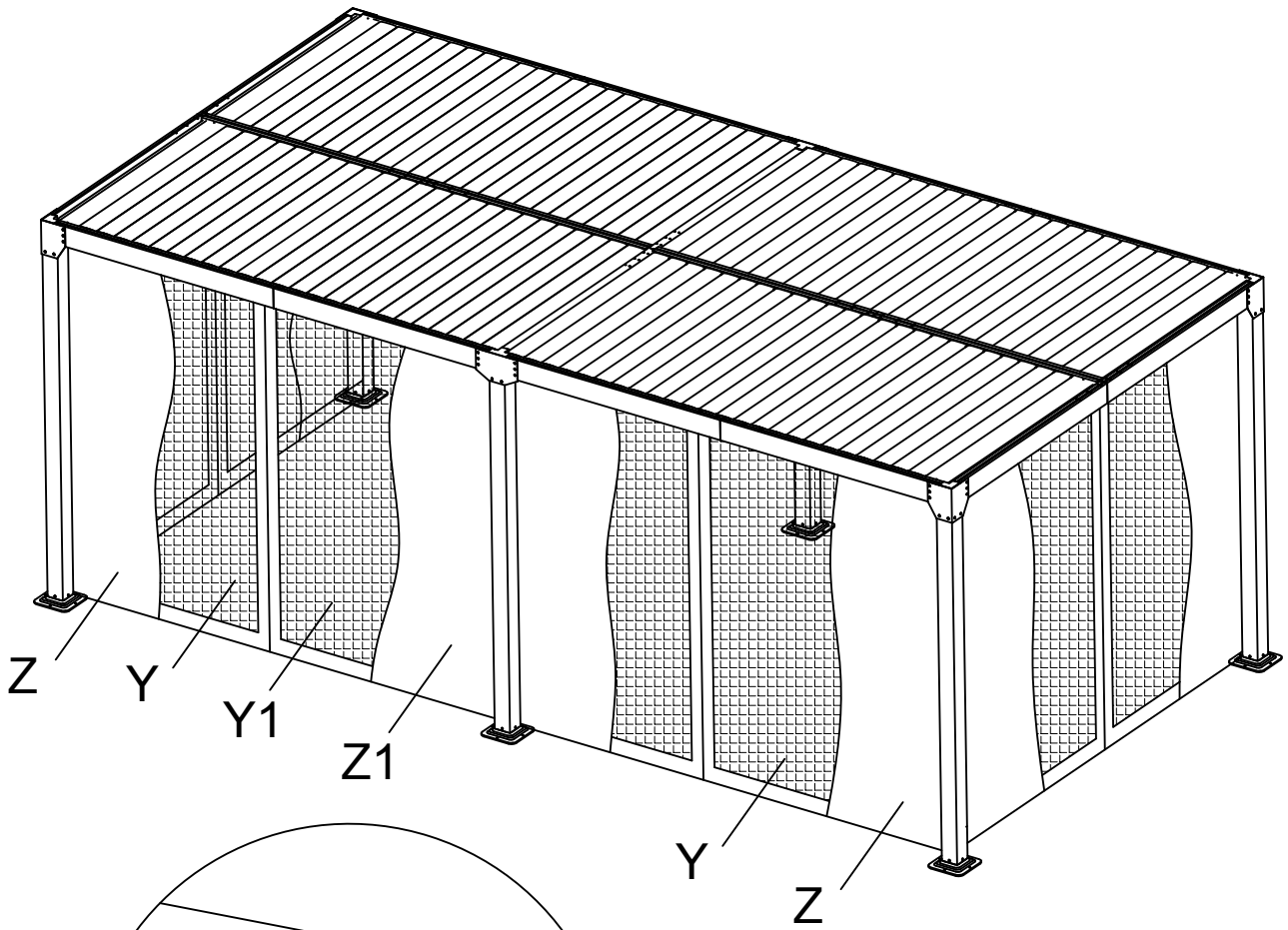

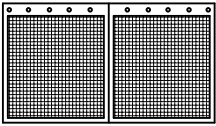
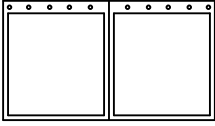
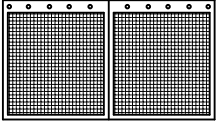
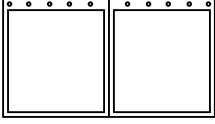
Y	4		Z	4	
Y1	2		Z1	2	

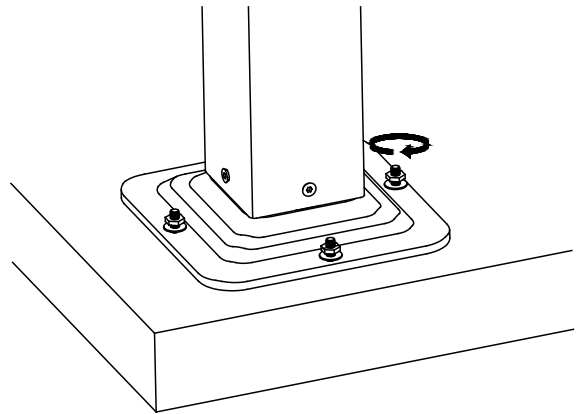
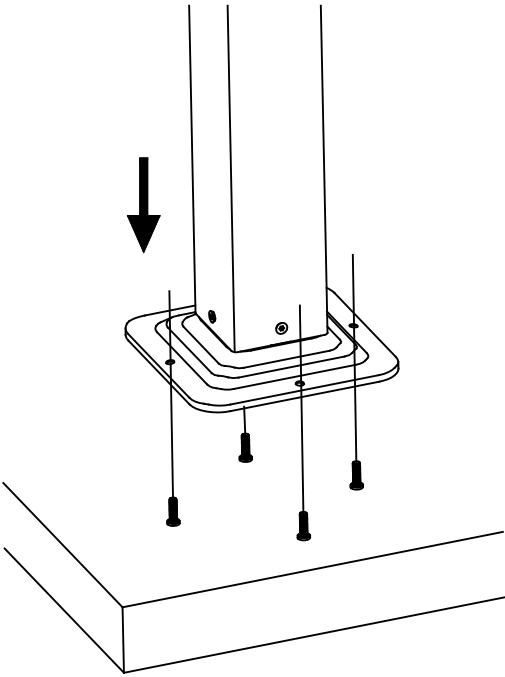
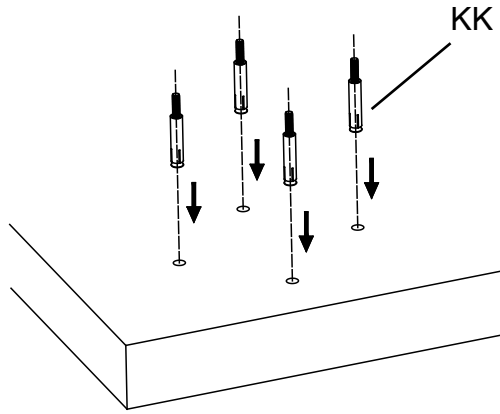
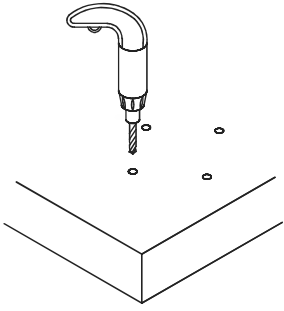

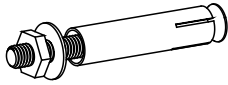
KK	24	
----	----	---