

13 x 15 FT

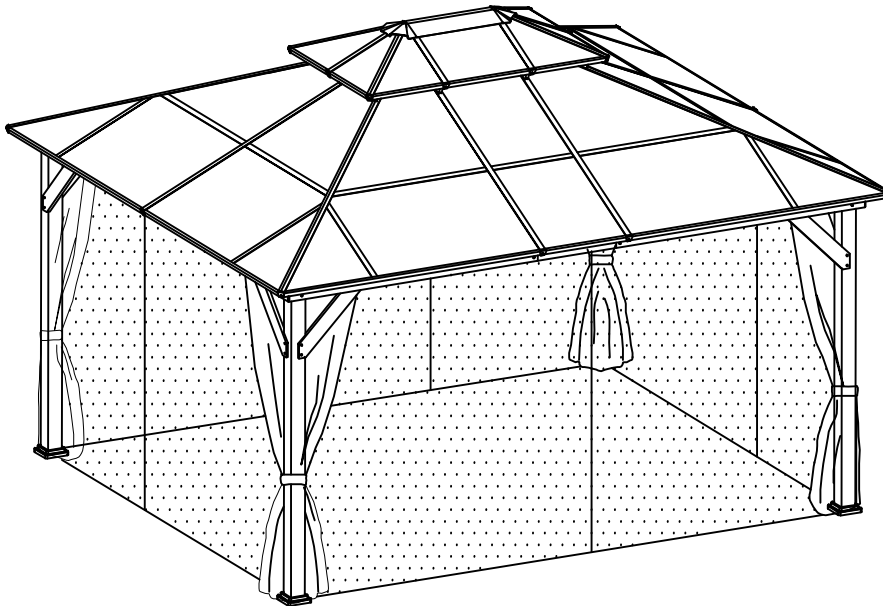

JFG017



At least need 4 people work together

REQUIRED TOOLS



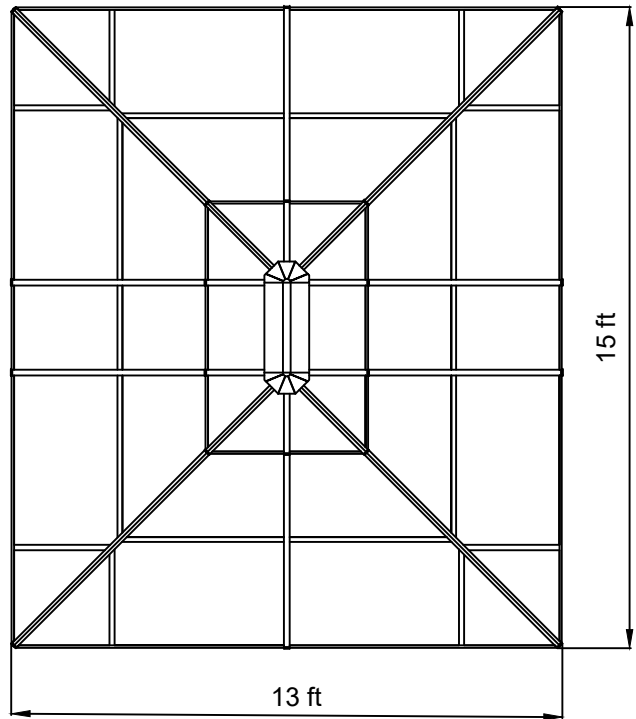
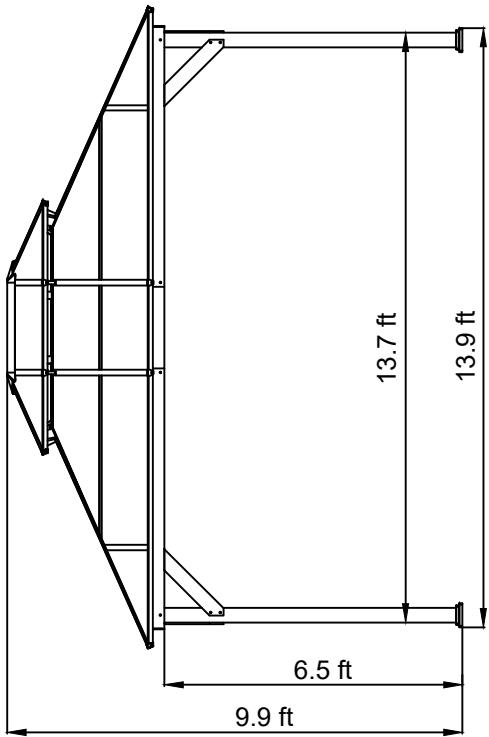
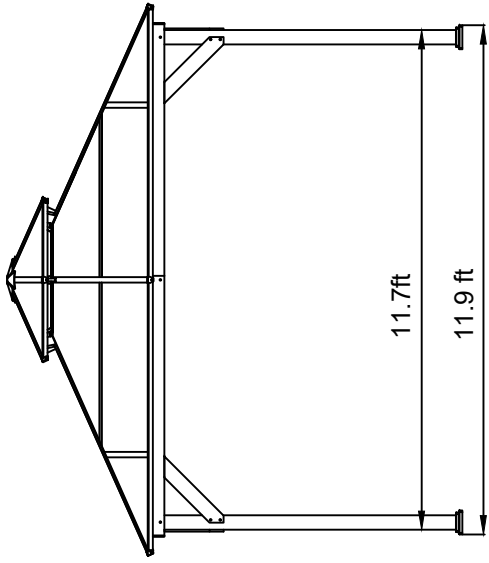

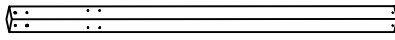

100 4x

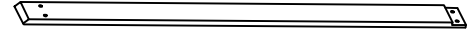

115 6x

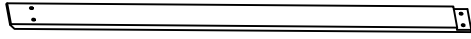

116 2x



103 4x



108 4x

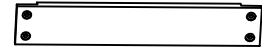

109 2x

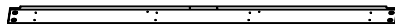

117 2x

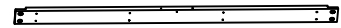

118 2x

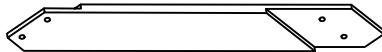

10 4x

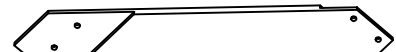

11 4x



A 4x

23-B001



B1 4x

23-B028



C1 6x

23-B029



D5 2x

23-B022

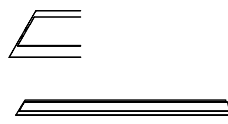

D6 4x

23-B030

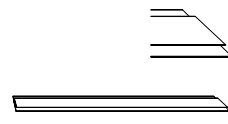

D7 4x

23-B031



D8 4x

23-B007



D9 4x

23-B008



E9 4x

23-B023

















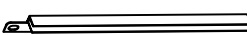

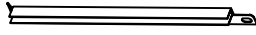
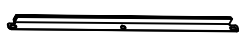

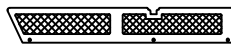

E10 4x

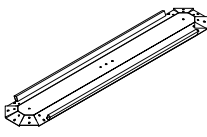
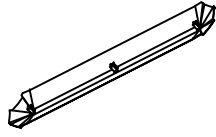
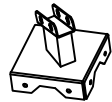



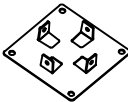

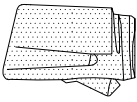
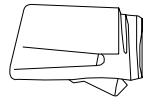

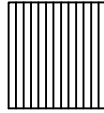
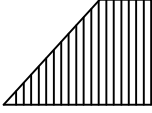
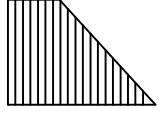
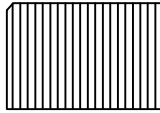
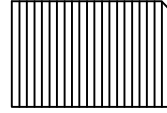
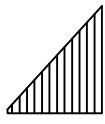
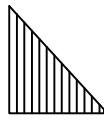
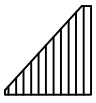
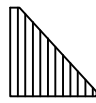

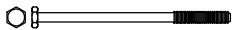

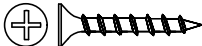

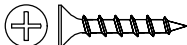

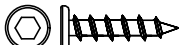



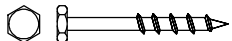

23-B034

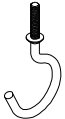
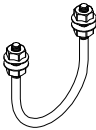

E11 4x

23-B035

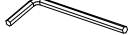
  E12 4x 23-B036	  E13 4x 23-B037	  E14 4x 23-B038	  E15 4x 23-B039
 E8 2x 23-B024	 G3 4x 23-B040	 G4 4x 23-B041	 H5 2x 23-B042
 H6 2x 23-B043	 H7 2x 23-B044	 L3 1x	 M3 1x
 J 4x	 K 6x	 N 12x	 N1 12x
 P 4x	 P1 4x	 X2 4x	 Y2 4x
 R 104x	 S7 6x	 S8 4x	 S9 4x
 S10 4x	 S11 4x	 S12 4x	 S13 4x
 T4 4x	 T5 4x		

 M10*160 (AA) 8x	 M6 (BB) 16x	 M5*40 (CC) 72x	 M6 (DD) 18x
 M5*30 (EE) 54x	 M8*35 (HH) 16x	 M8*35 (II) 16x	 M8*25 (KK) 28x
 M10 (LL) 8x	 M8 (MM) 16x	 M10 (NN) 24x	 M10*80 (OO) 8x
 M6x15 (QQ) 58x	 M5x15 (SS) 12x	 M6x35 (TT) 8x	 (ZZ) 2x
 (VV) 1x	 M6x10 (XX) 10x	 (PP) 8x	 M3 Drill (RR) 2x
 M6 (Z1) 2x	 M10 (Z4) 2x	 M8 (Z2) 2x	 M6 (Z5) 2x

<1>

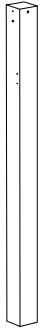

100 4x

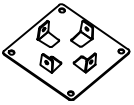

P 4x



P1 4x

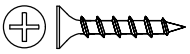

M5*30

EE 16x

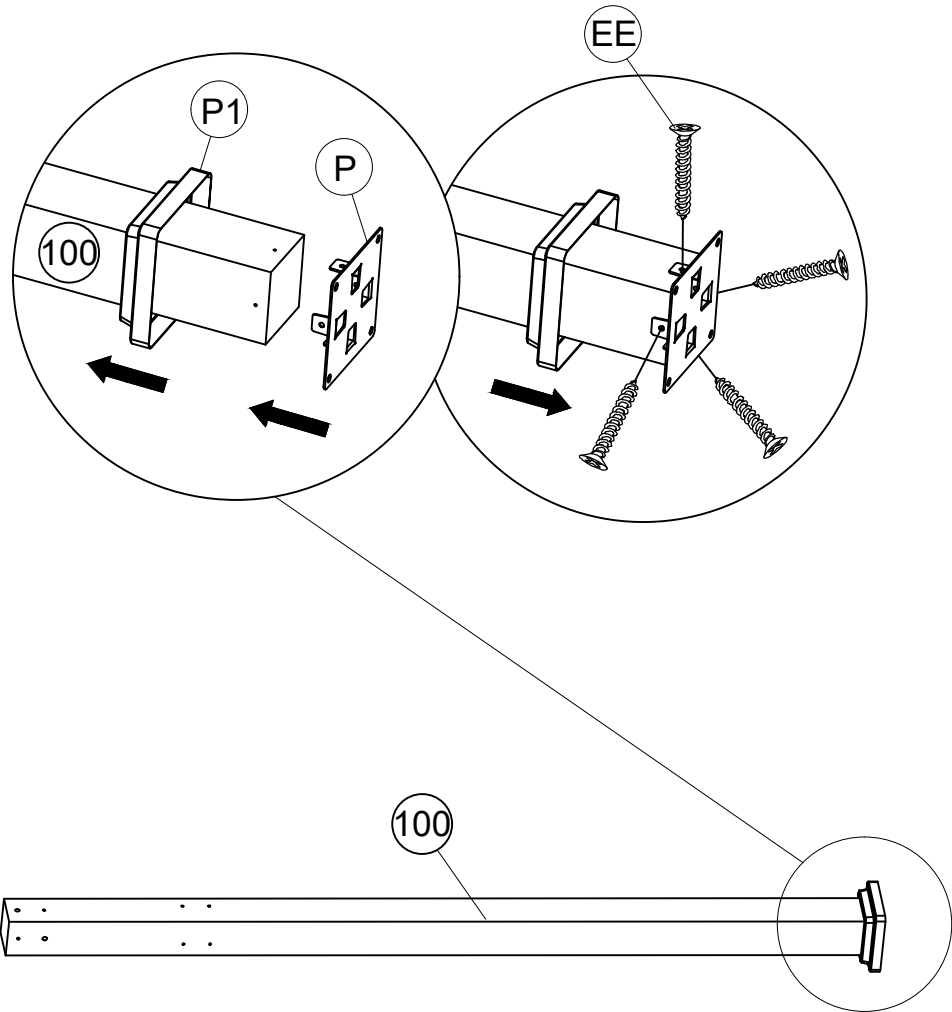

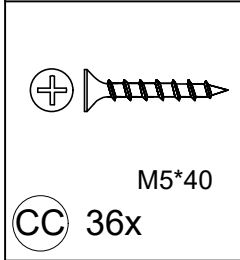
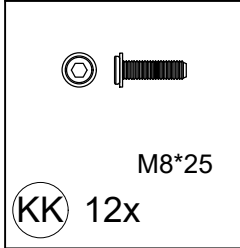
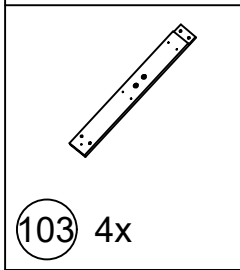
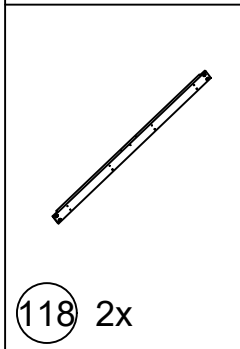
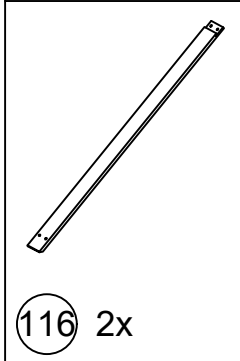
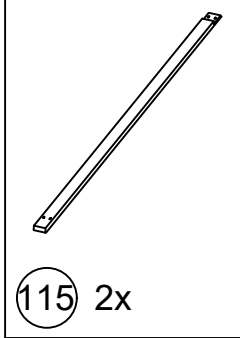

8

<2>

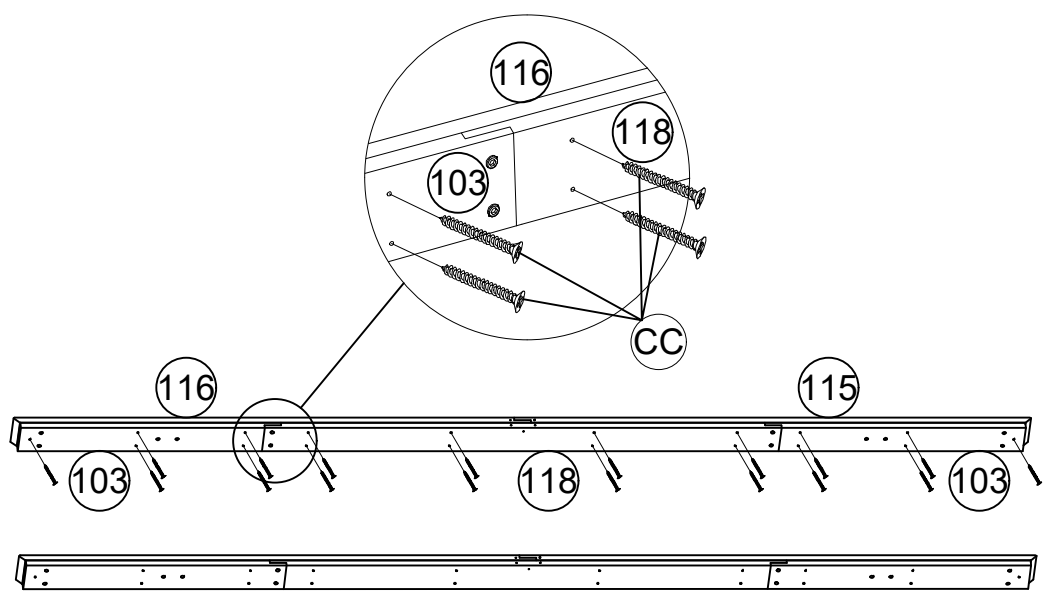
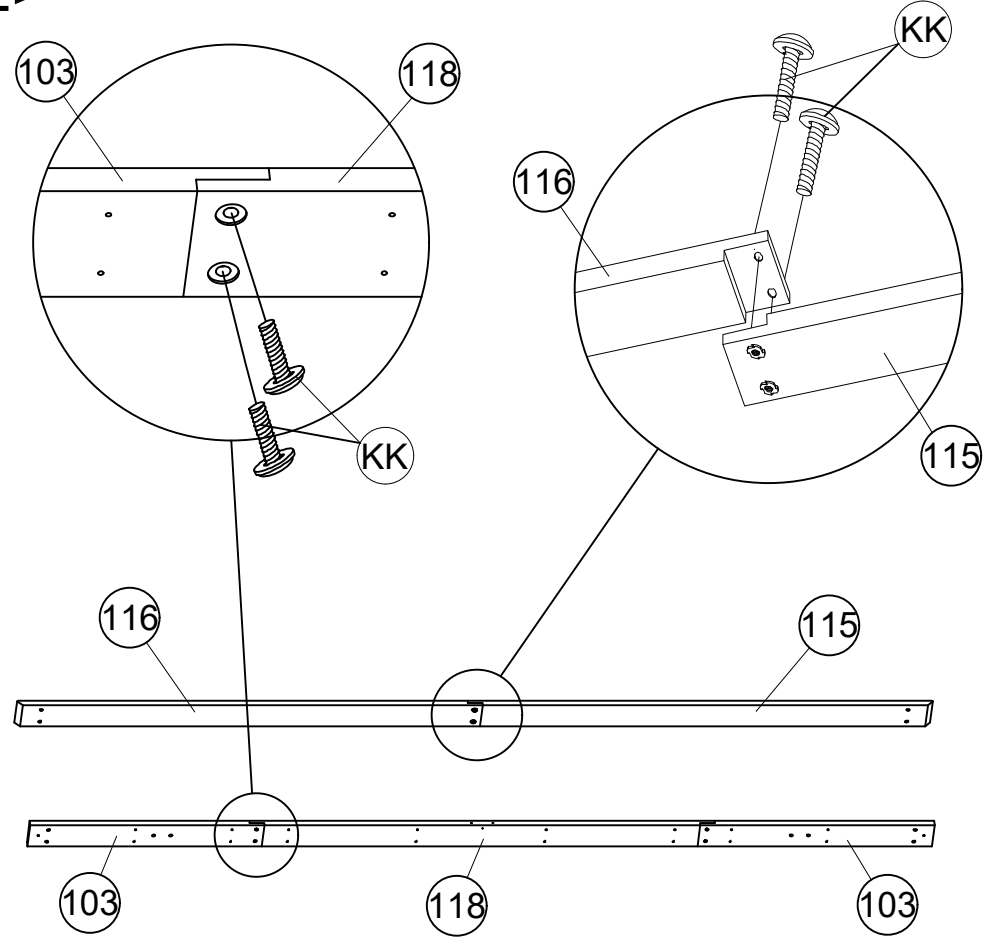

Connect the outer beams (116,115) and inner beams (103,118) separately with screw KK, and then combine the outer beams and inner beams together with self-tapping screw CC.

Attention:

Pay attention to the side of Beam (116) and Beam (115) when join them with Beam (118) and Beam (103) .

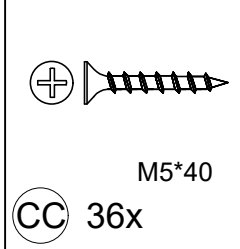
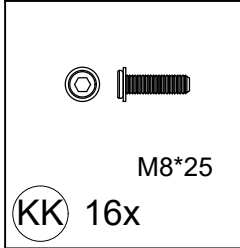
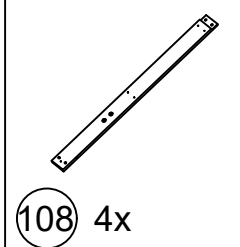
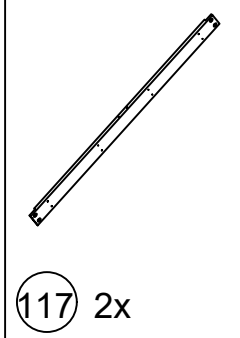
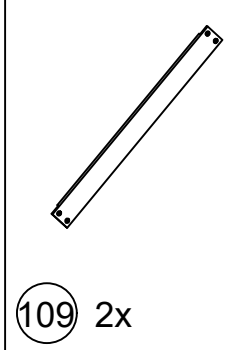
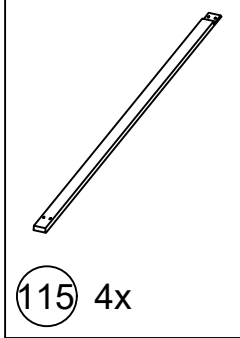

9

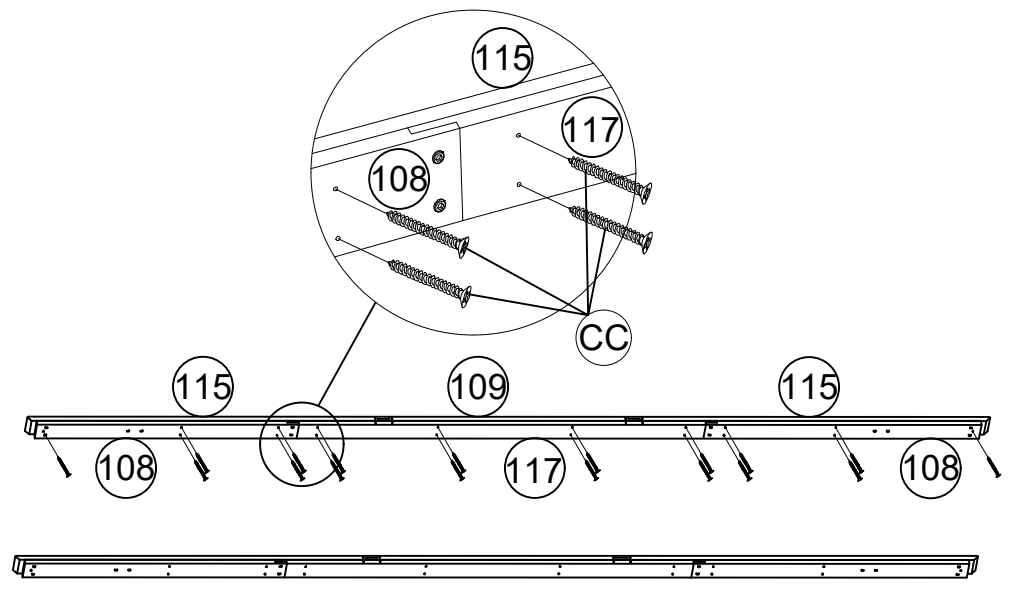
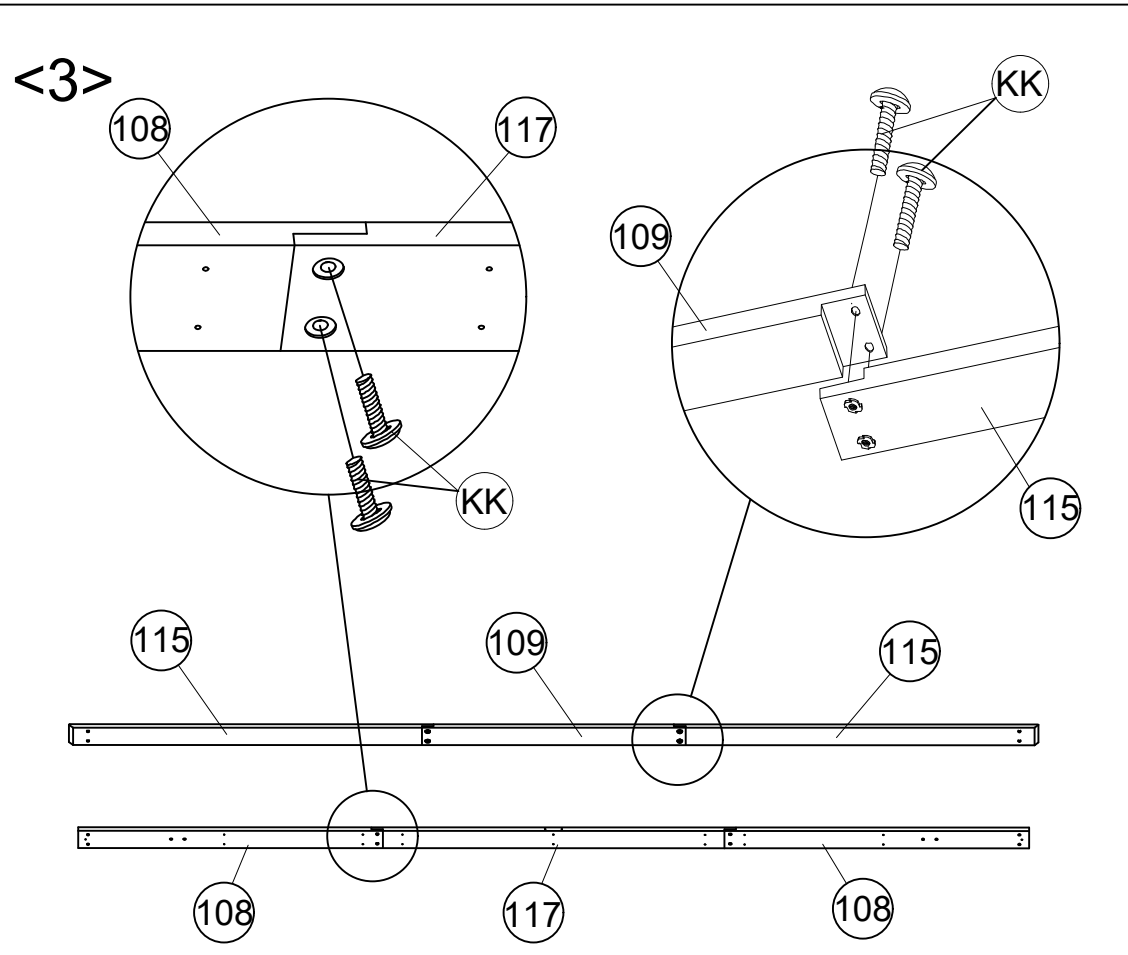

Connect the outer beams (115,109) and inner beams (108,117) separately with screw KK, and then combine the outer beams and inner beams together with self-tapping screw CC.

Attention:

Pay attention to the side of Beam (115) and Beam (109) when join them with Beam (117) and Beam (108) .

<4>

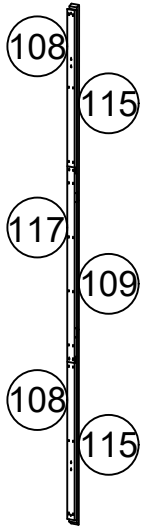

2x

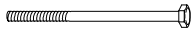

M10*165

AA 4x

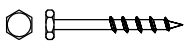

M10*80

OO 4x



M10

NN 12x



M10

LL 4x

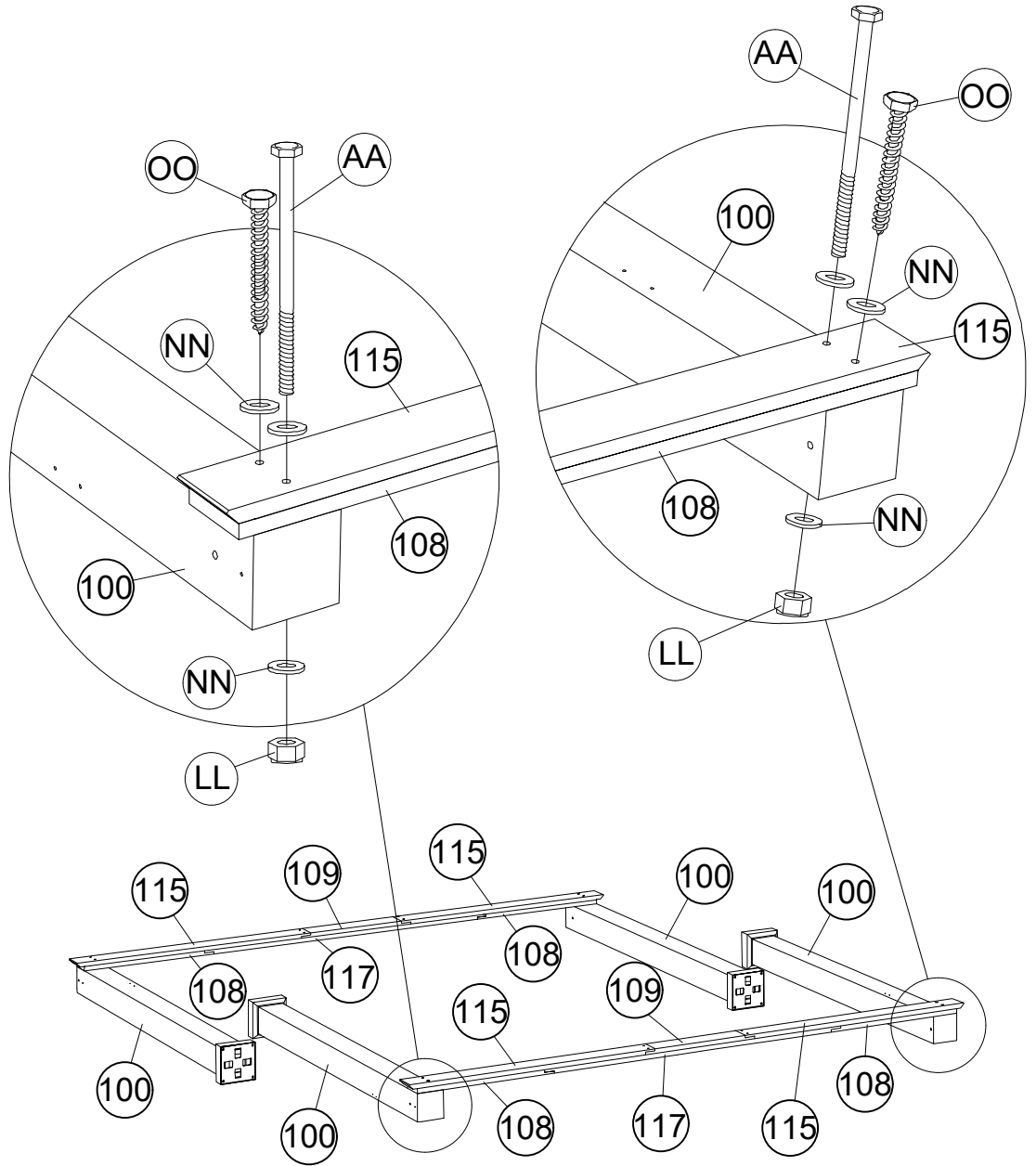

10

<5>

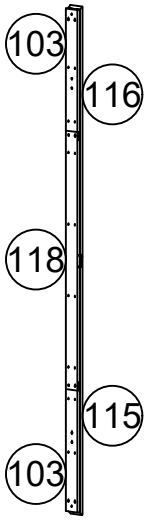

2x

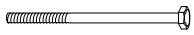

M10*165

AA 4x



M10*80

OO 4x



M10

NN 12x



M10

LL 4x

11

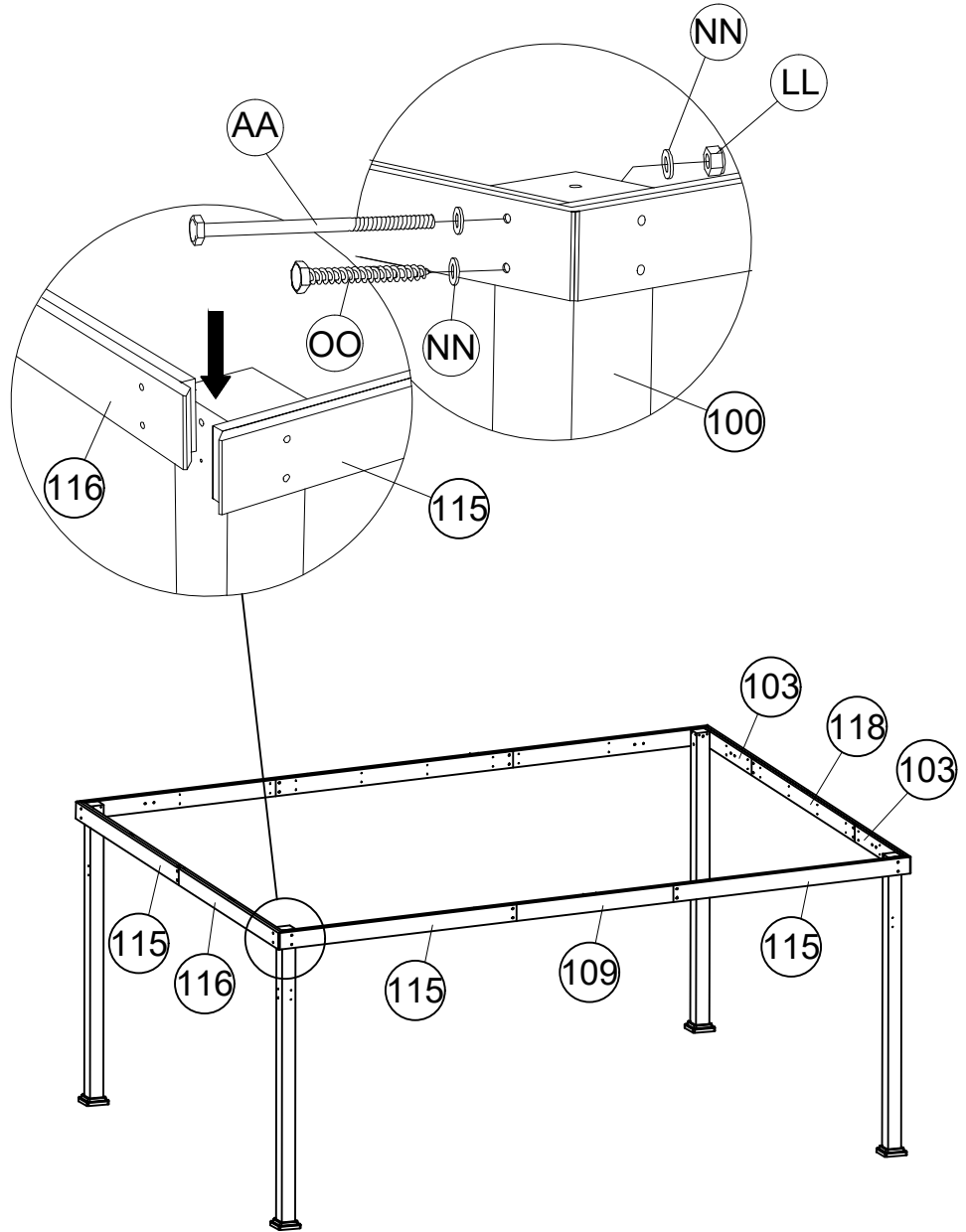

<6>

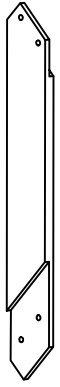

10 4x

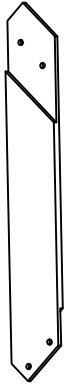

11 4x



M8*35

HH 16x

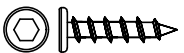

M8*35

II 16x



M8

MM 16x

I d1=d2

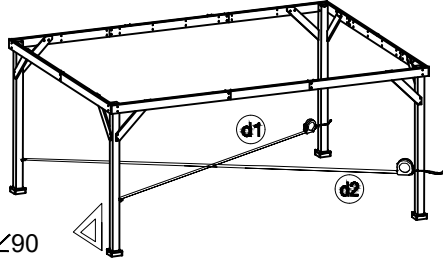

Rt ∠90

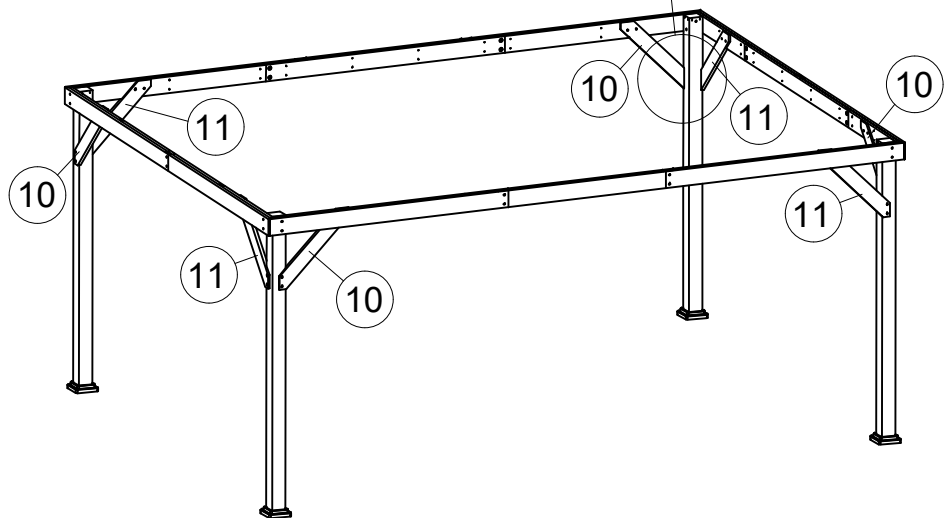
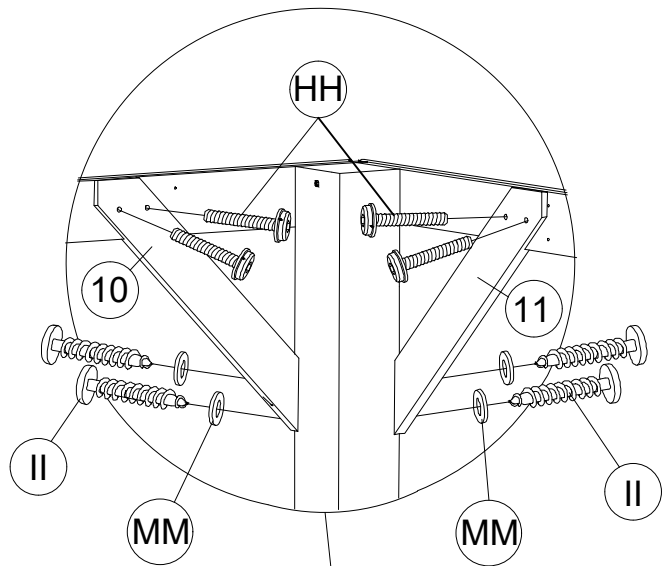

12



J 4x

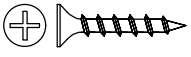

M5*30

EE 16x

<7>

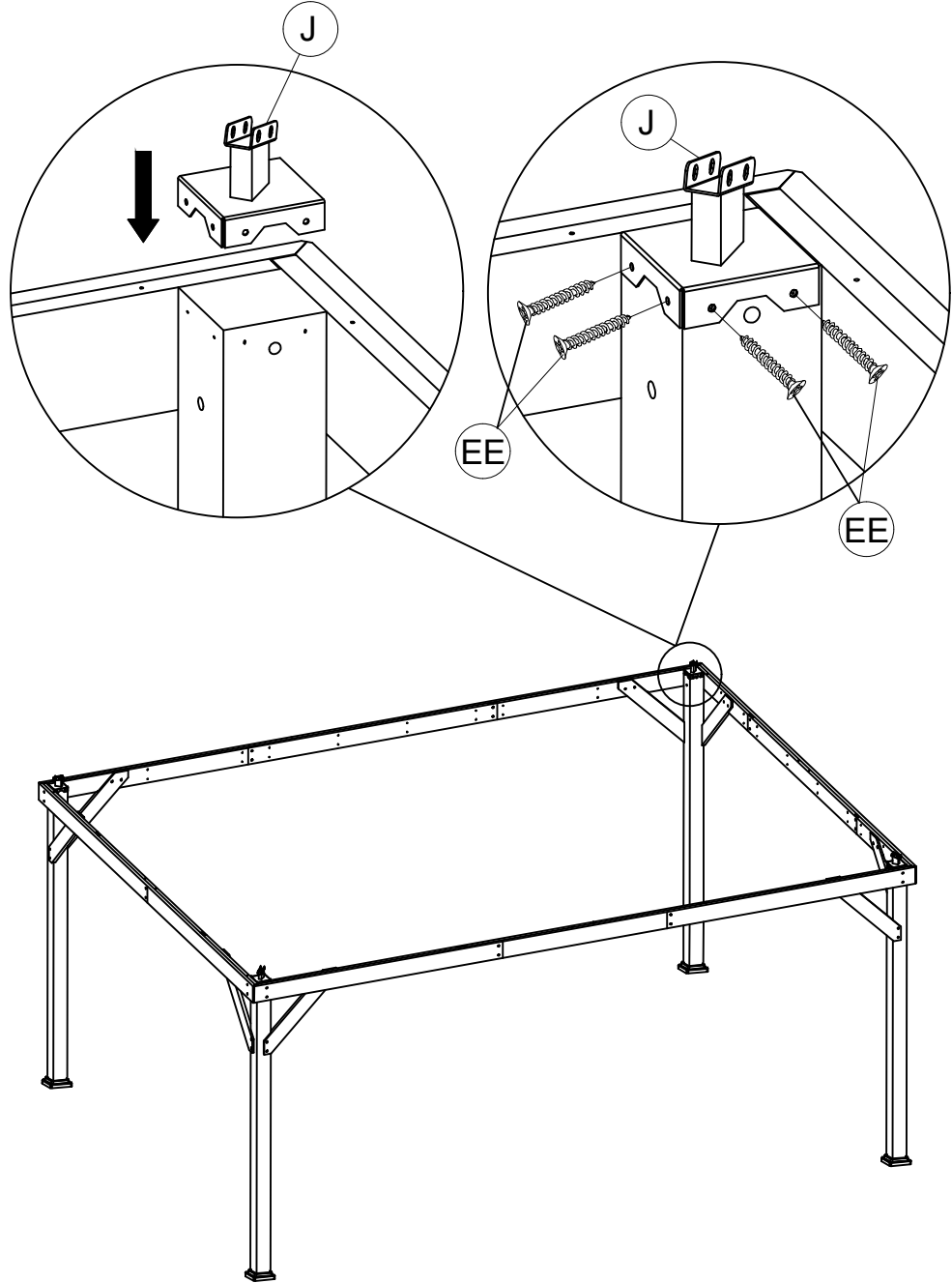

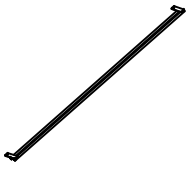

G3 4x



G4 4x



M5*30

EE 16x

<8>

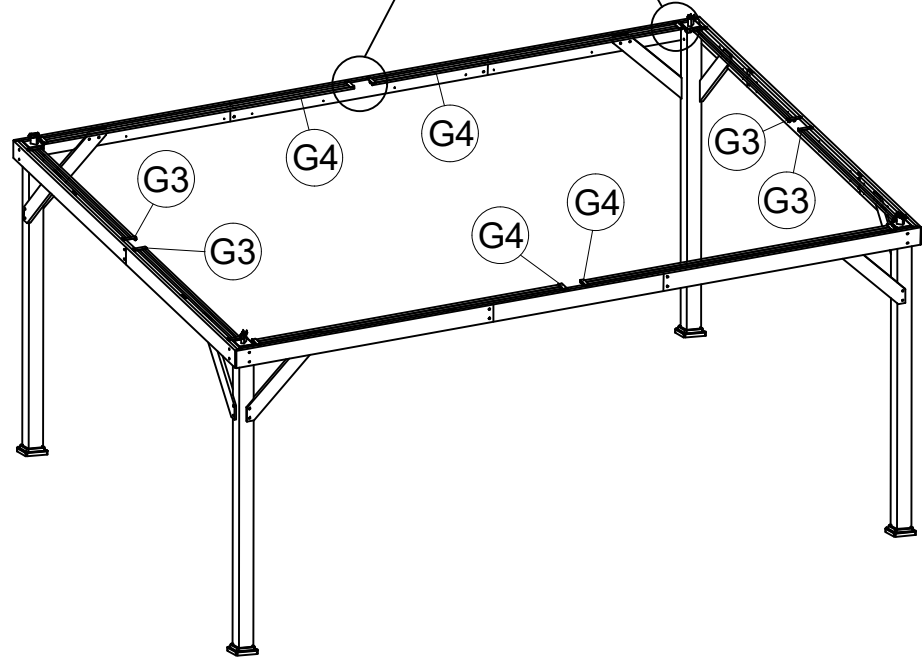
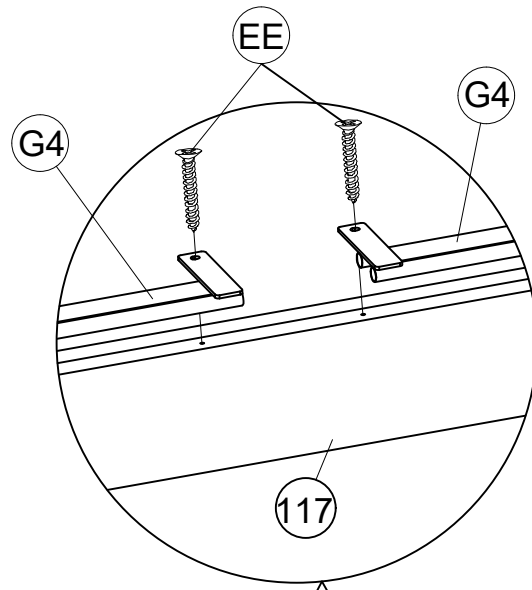

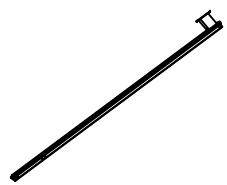

A 4x



B1 4x

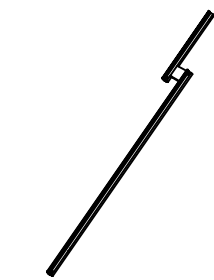

C1 6x

<9>

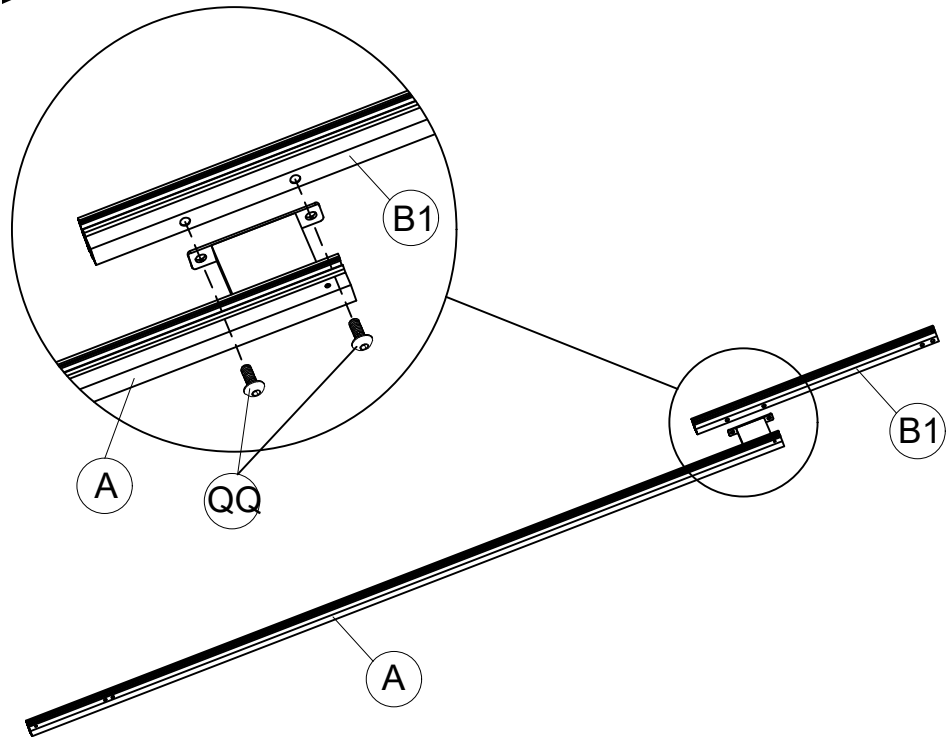

K 6x



QQ 8x
M6x15



SS 12x
M5x15

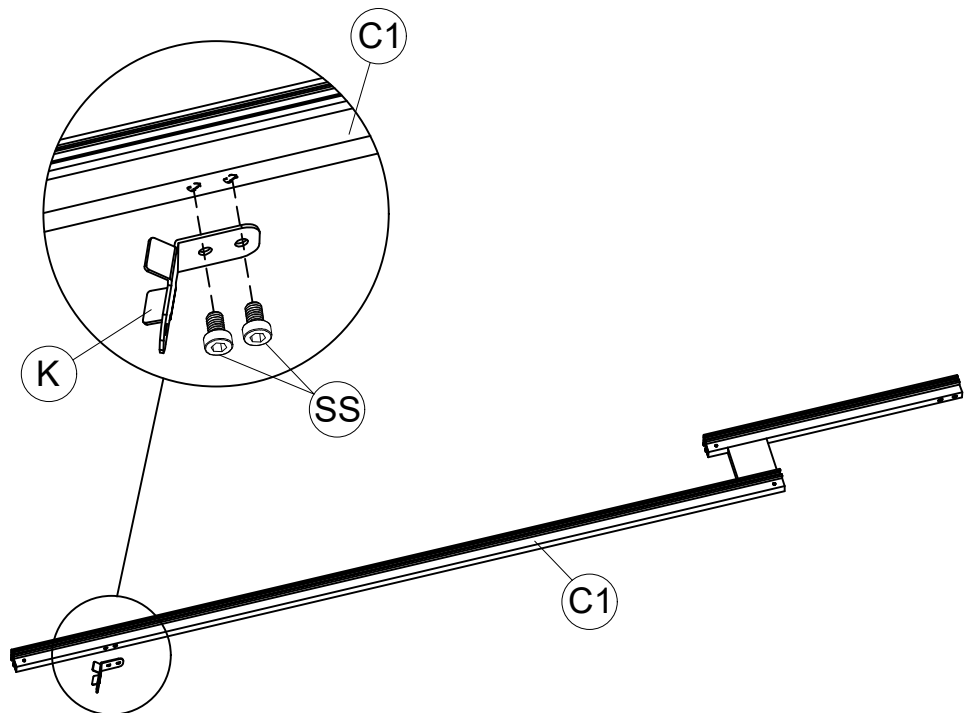

15

<10>

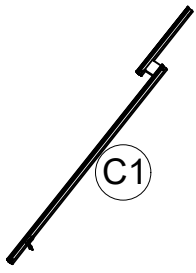

4x

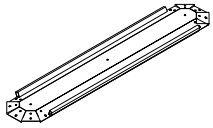

L3 1x



M6x15

QQ 8x

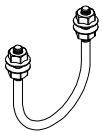

VV 1x

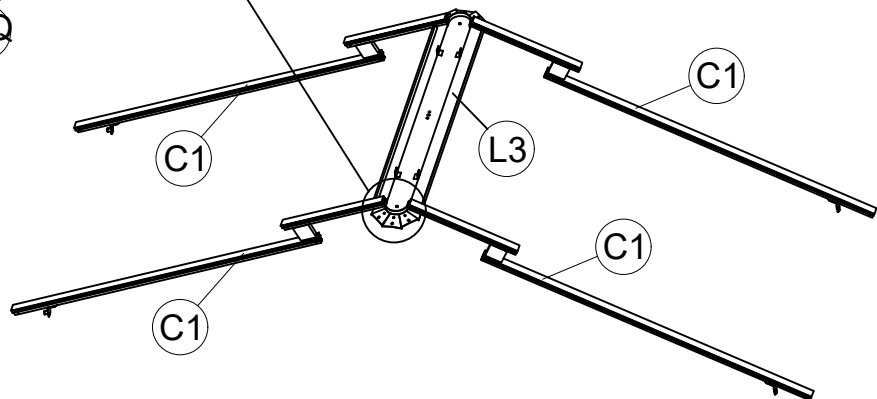
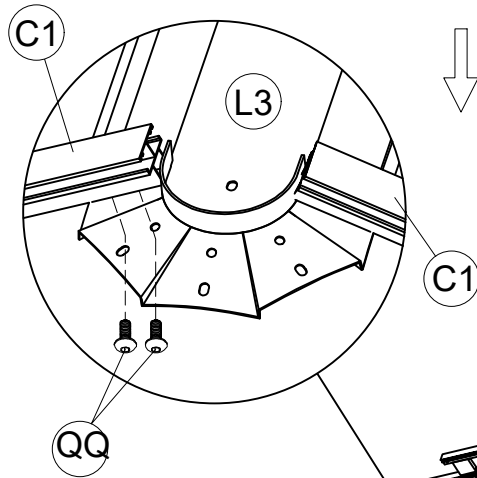
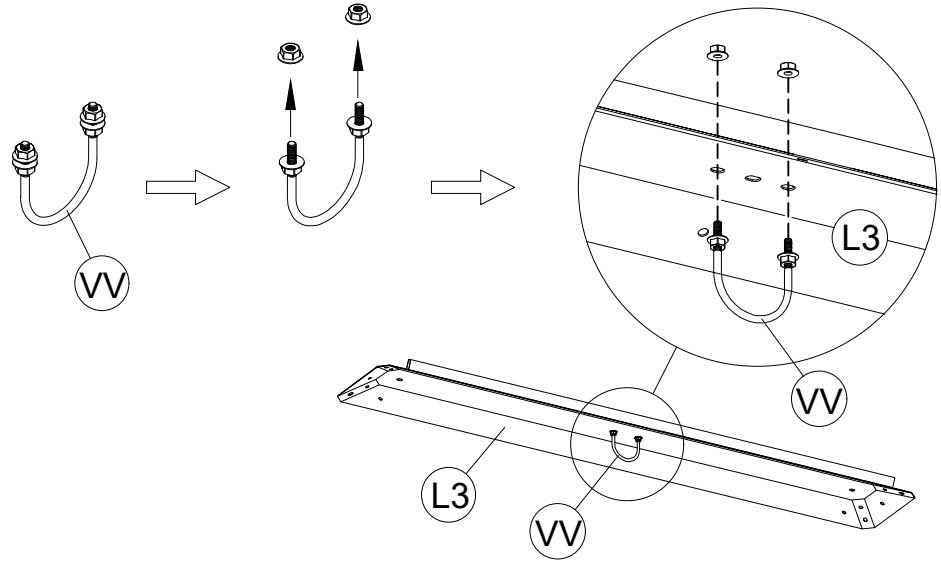

16

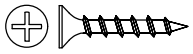

M5*30

EE 4x

<11>

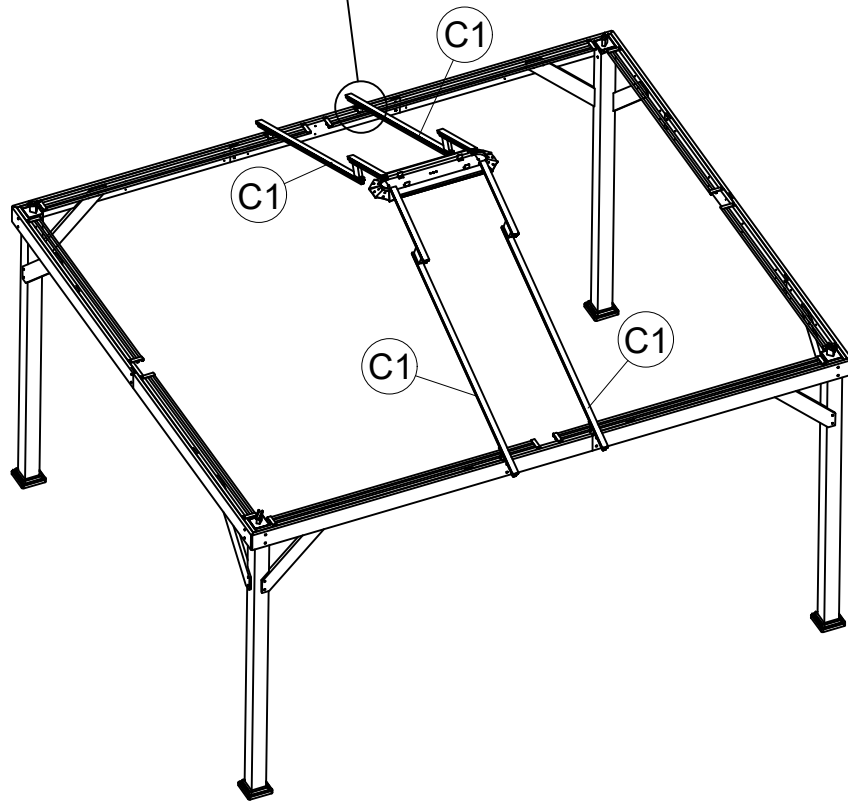
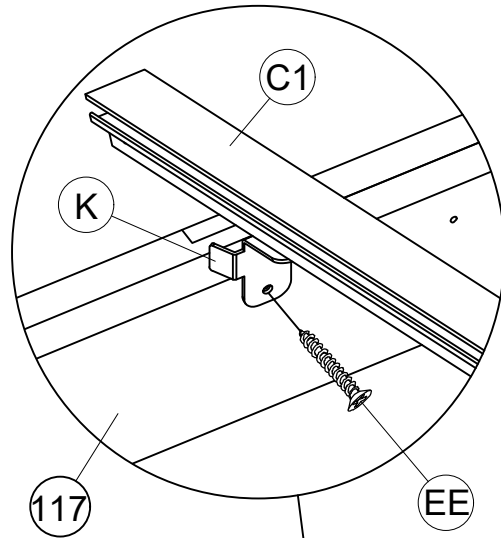

<12>

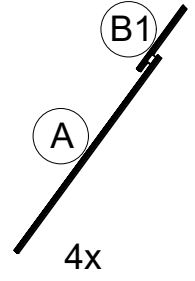
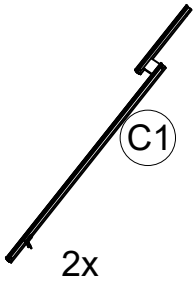

QQ 12x

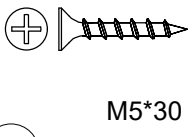

EE 2x

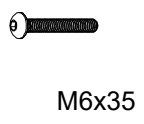

TT 8x



DD 8x



BB 16x

18

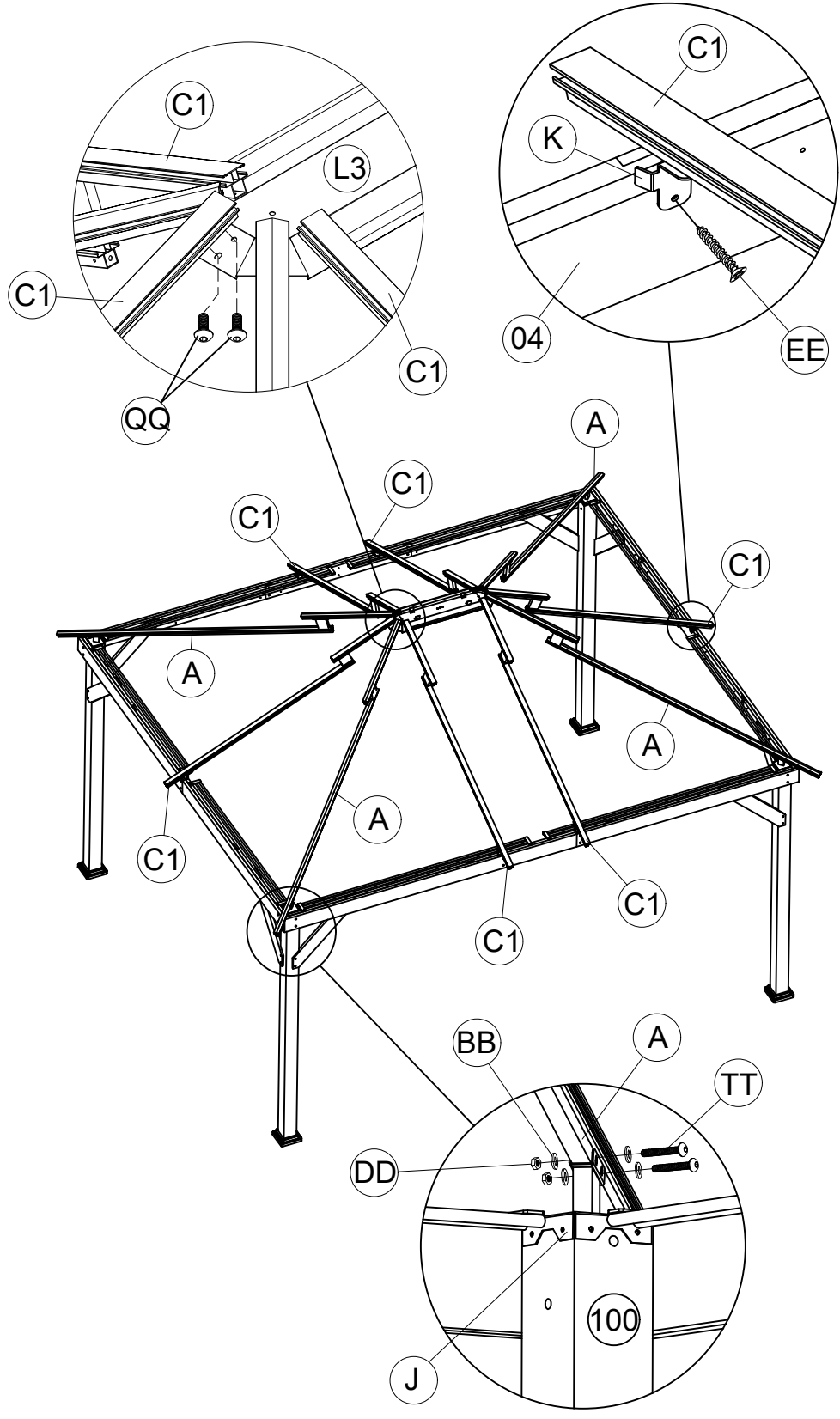

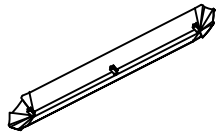

M3 1x



ZZ 2x

<13>

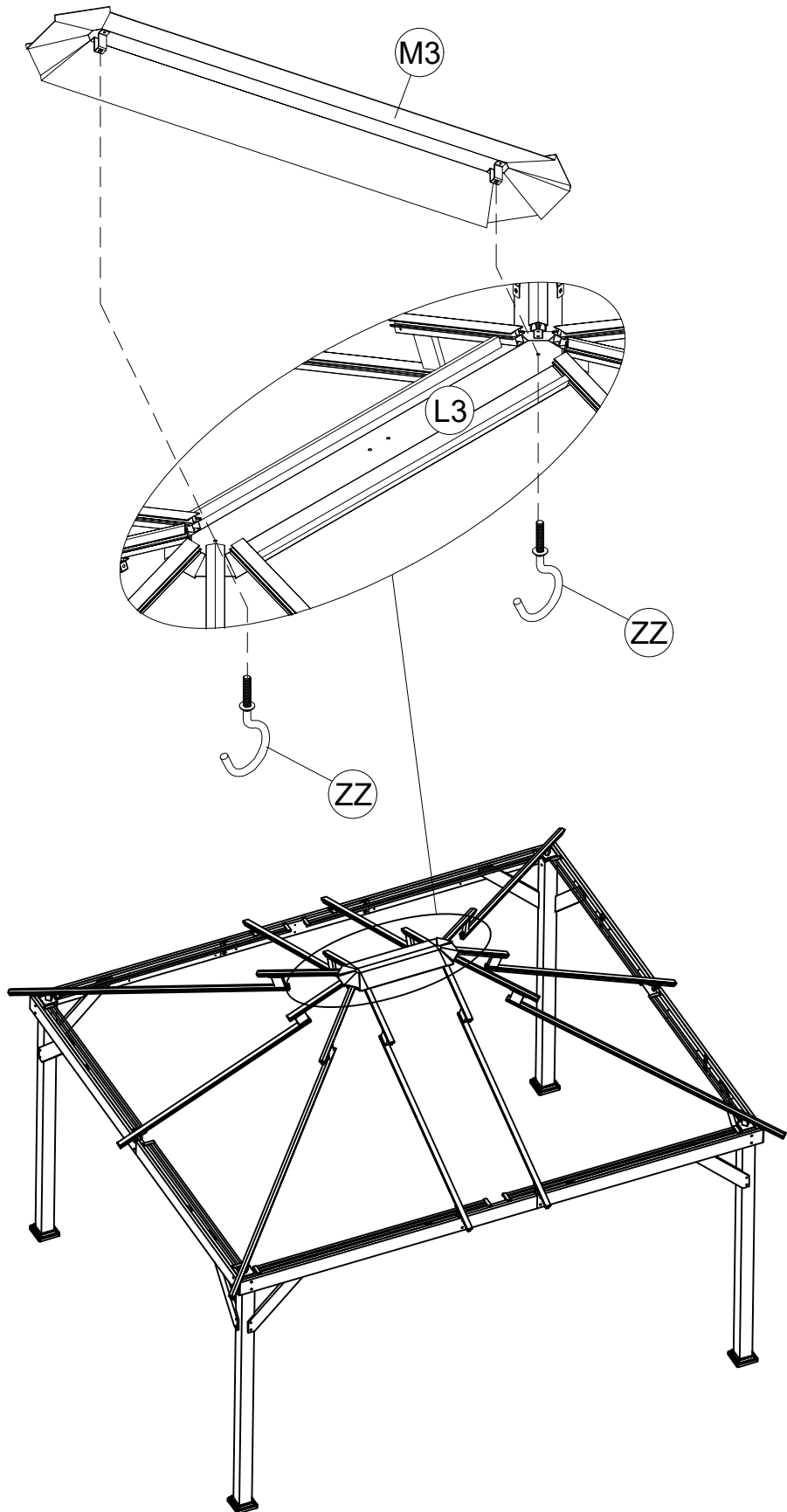



T4 4x



T5 4x

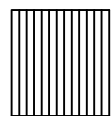

S7 2x

<14>

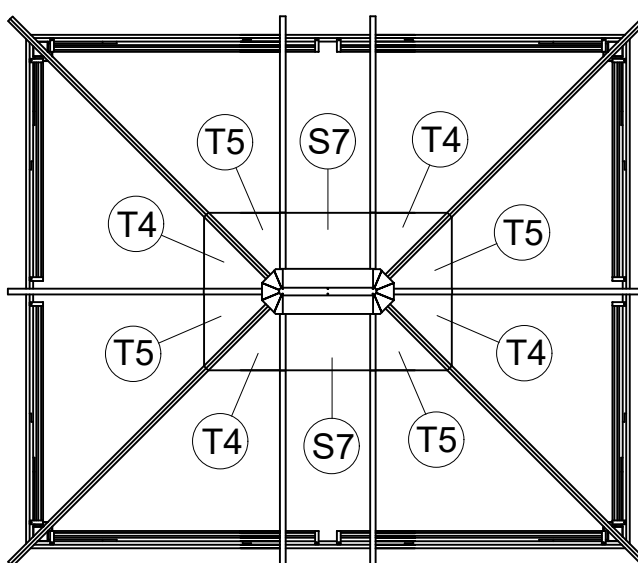
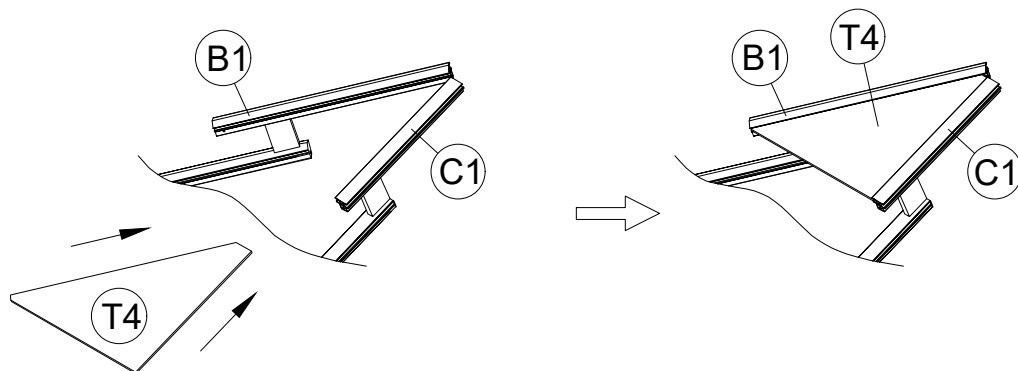
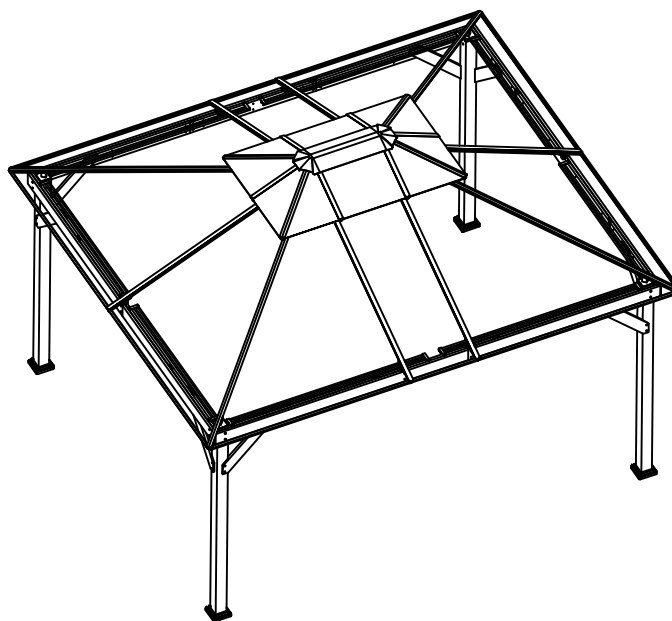

<15>

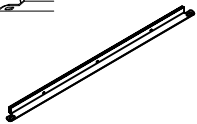

E9 2x



E12 4x

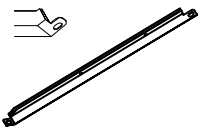

E13 4x



N 4x



N1 6x



M6x15
QQ 10x

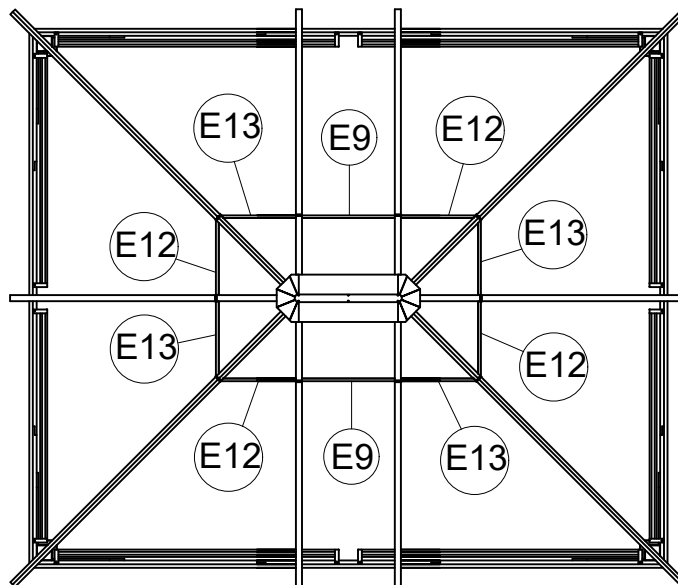
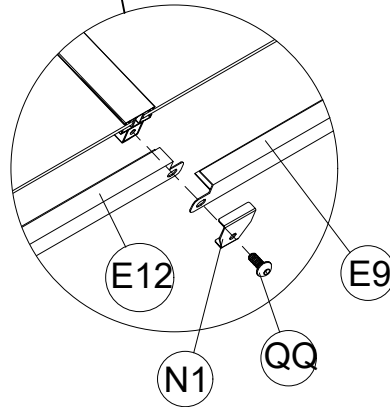
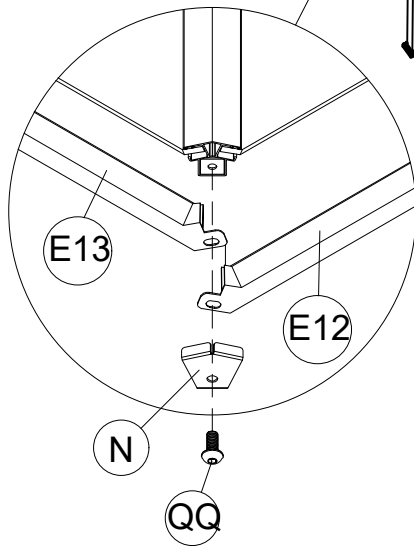
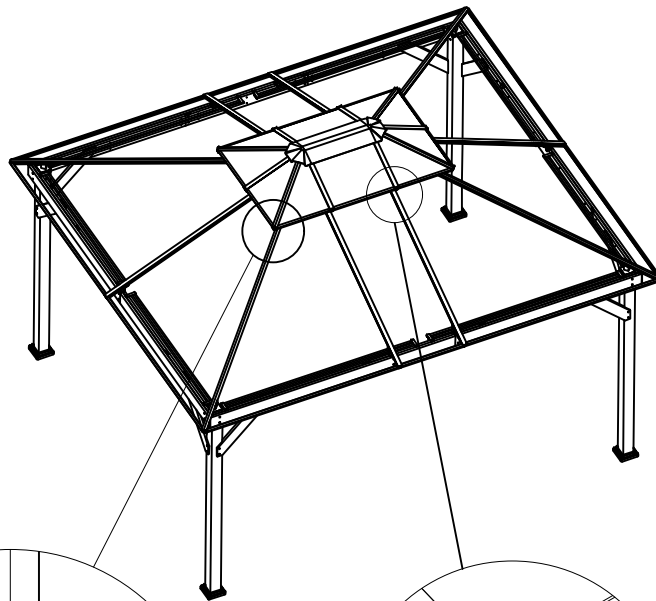

<16>

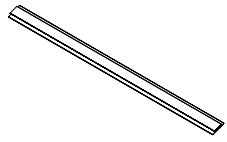

D5 2x

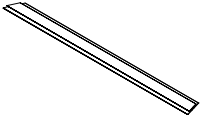

D6 4x

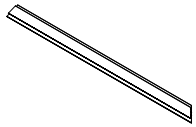

D7 4x

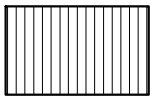

S7 2x

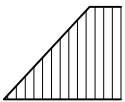

S8 4x

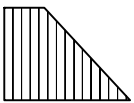

S9 4x

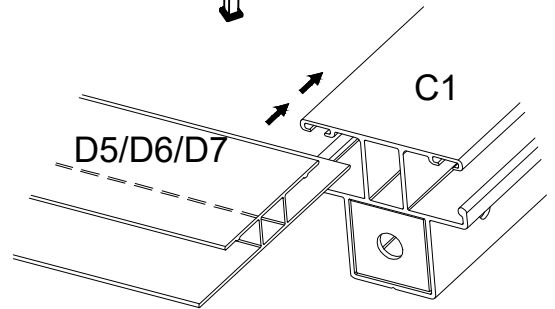
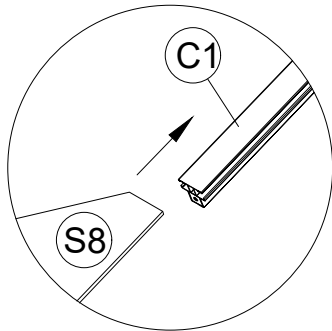
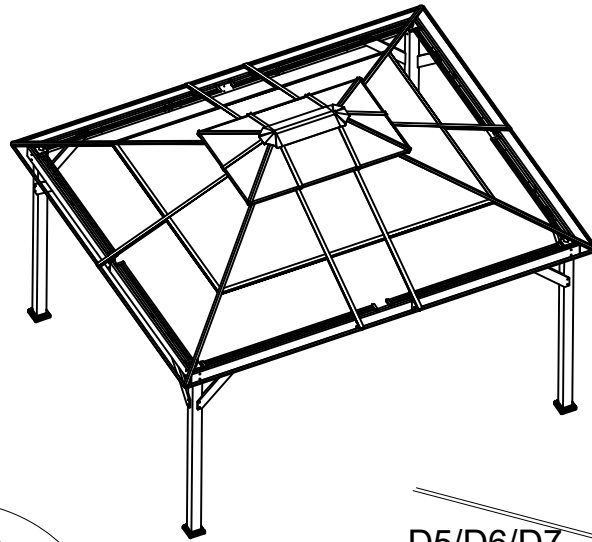

Note:

When D6 or D7 or D5 slide into the C, the wide side must be face down and narrow side face up, otherwise will cause water leaking

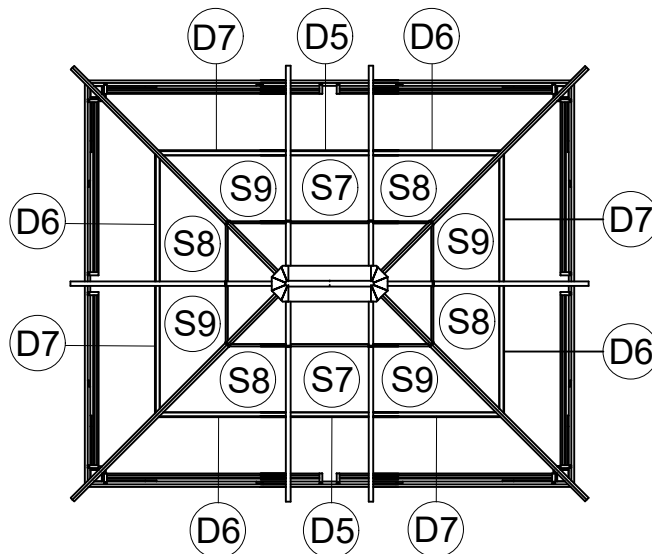
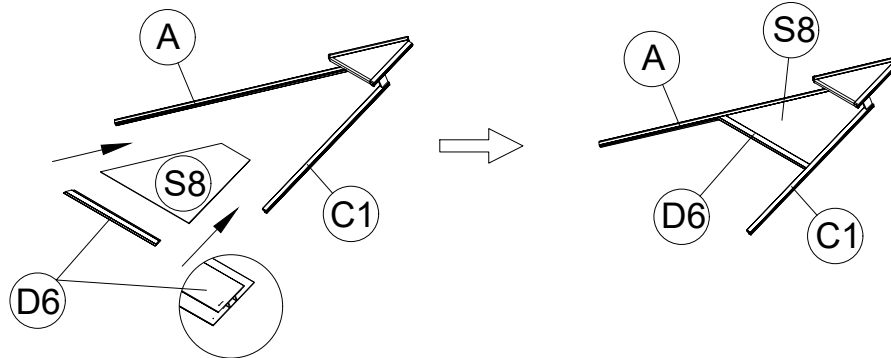

<17>

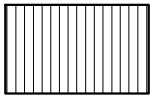

S7 2x

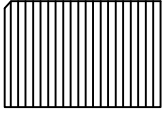

S10 4x

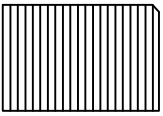

S11 4x

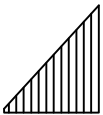

S12 4x

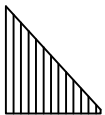

S13 4x



D8 4x



D9 4x

23

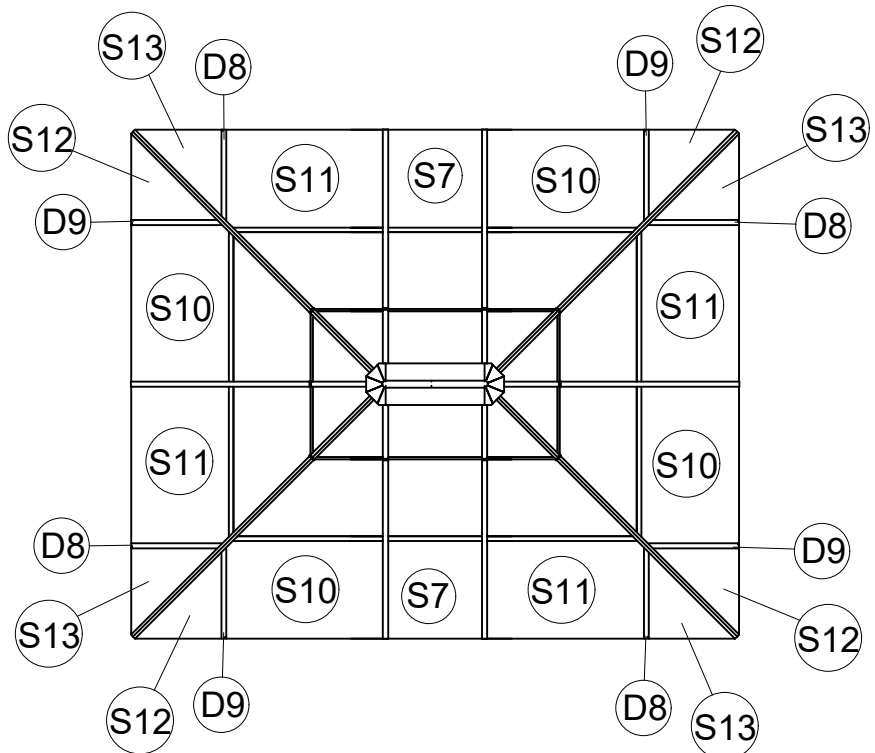
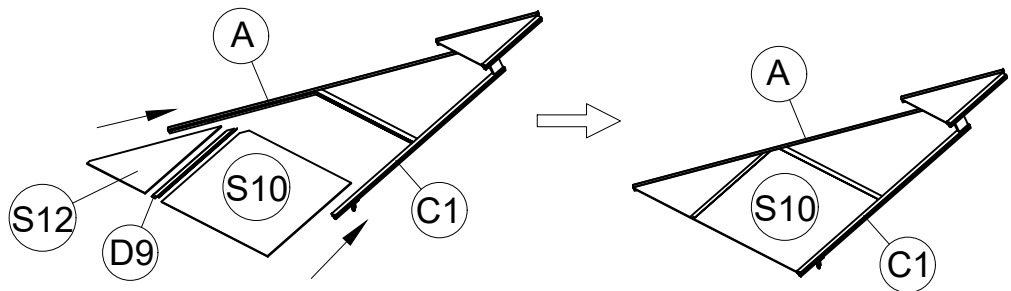
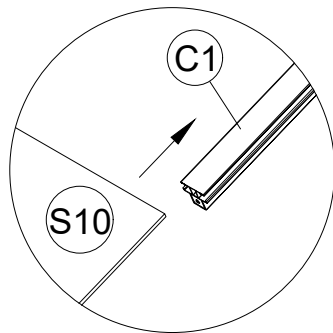
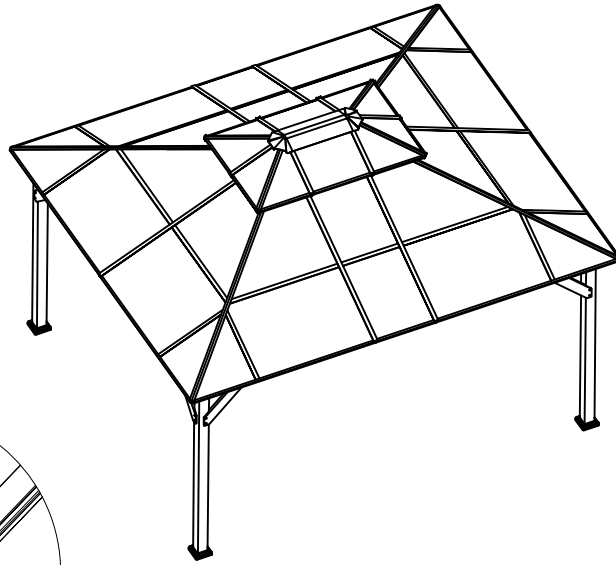

<18>

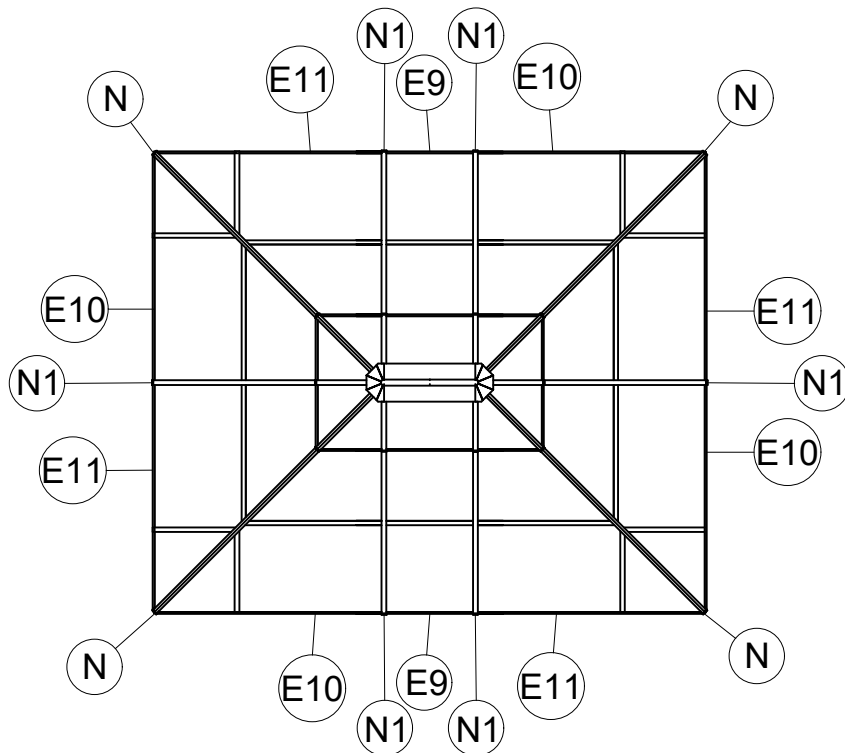
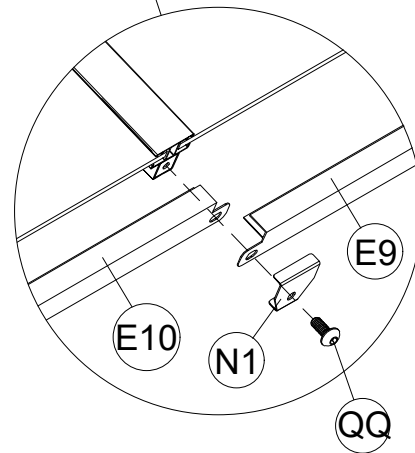
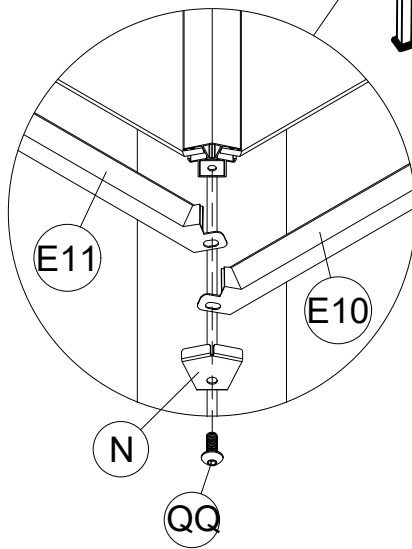
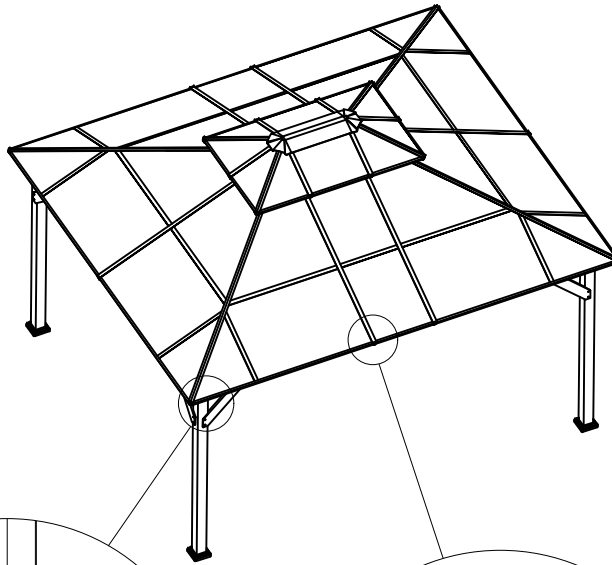

E9 2x

E10 4x

E11 4x

N 4x

N1 6x

QQ 10x
M6x15

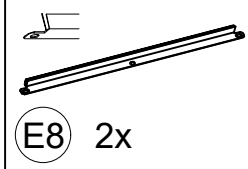

E8 2x

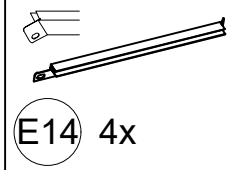

E14 4x

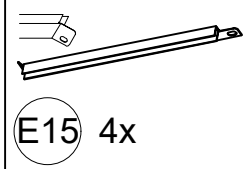

E15 4x

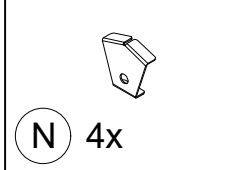

N 4x

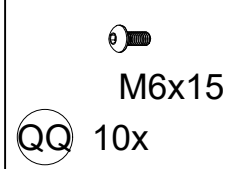

M6x15
QQ 10x

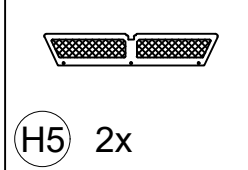

H5 2x

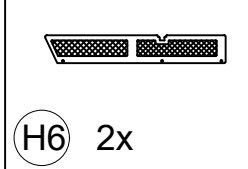

H6 2x

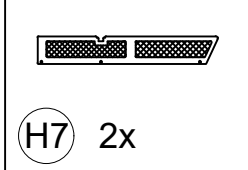

H7 2x

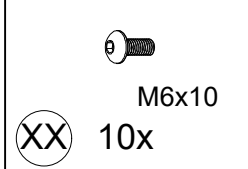

M6x10
XX 10x



Nut M6
DD 10x

25

<19>

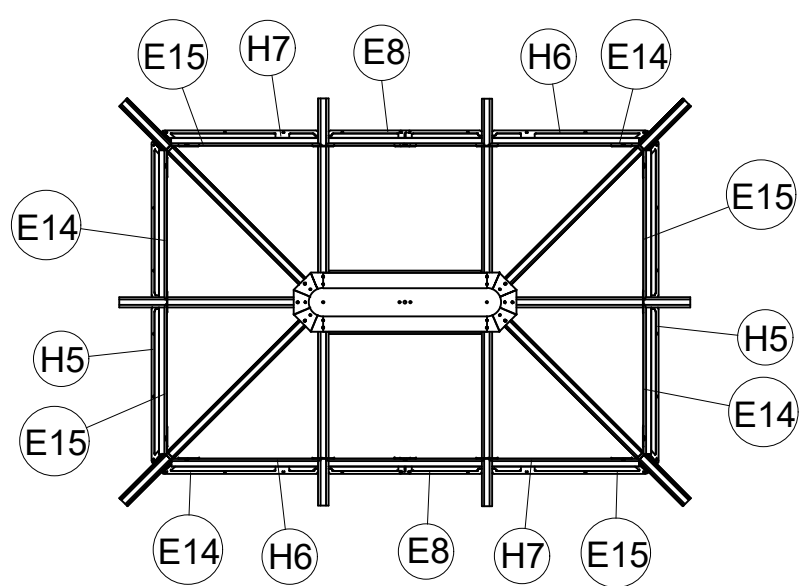
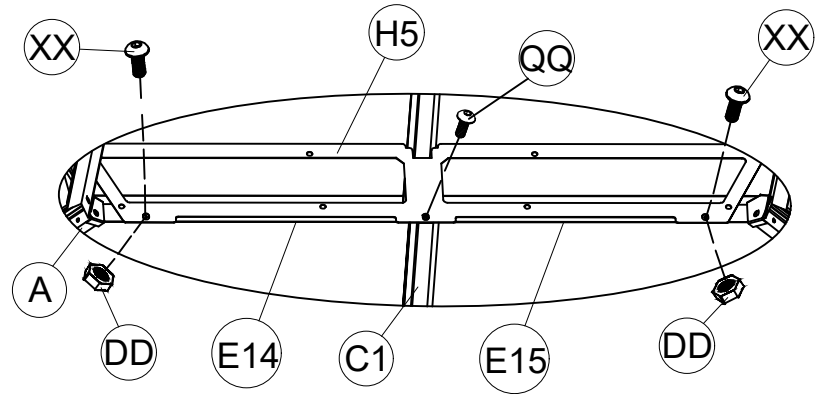
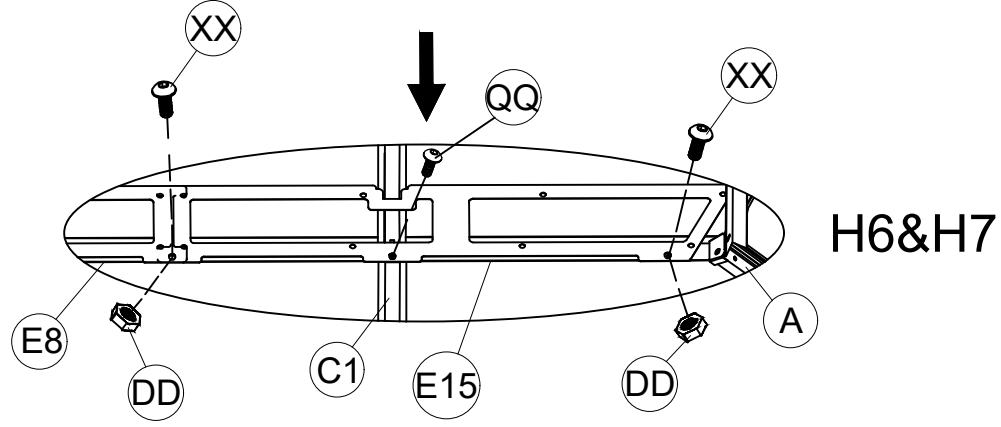
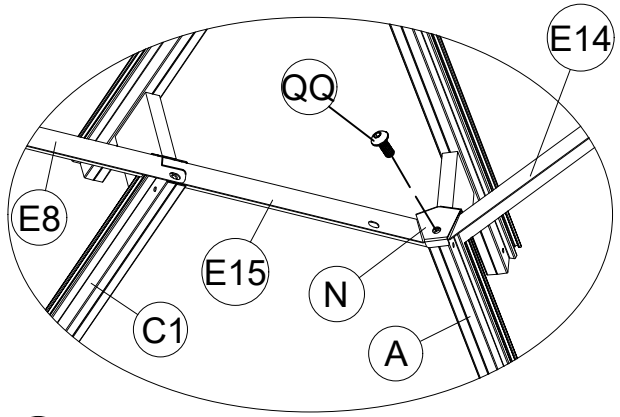

Upward view of the roof

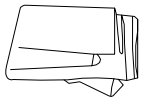

<20>

Y2 4x



R 52x

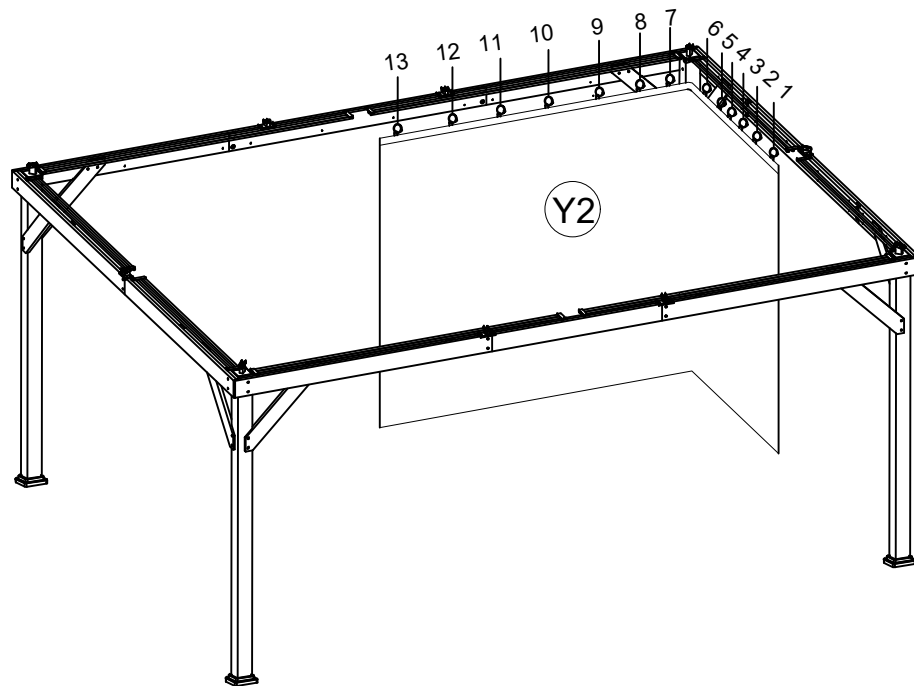
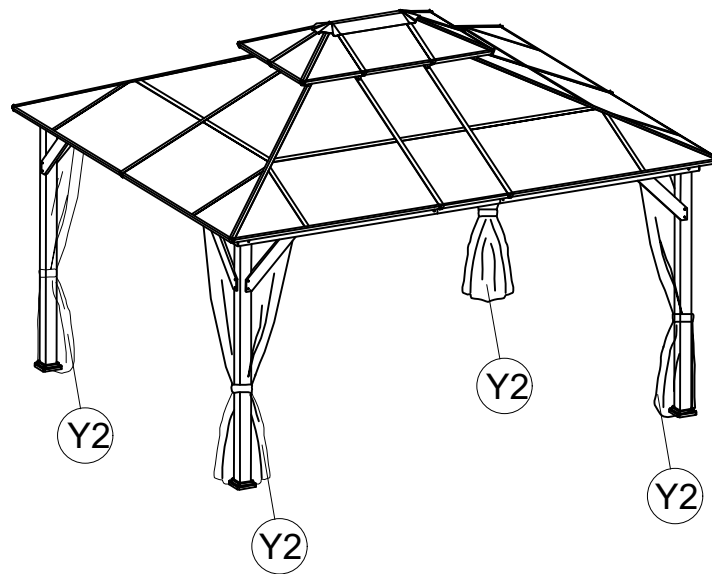
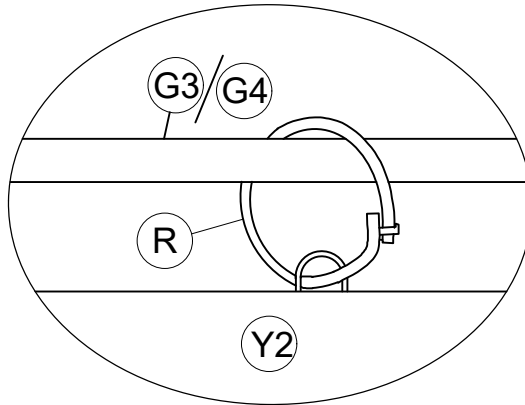

26

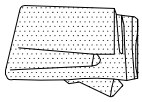

<21>

X2 4x



R 52x

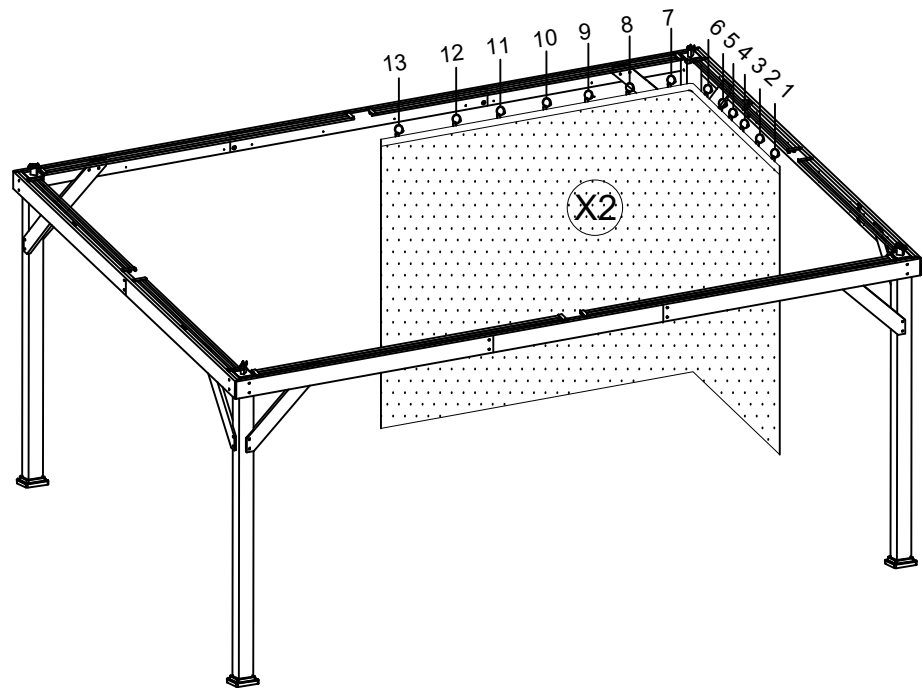
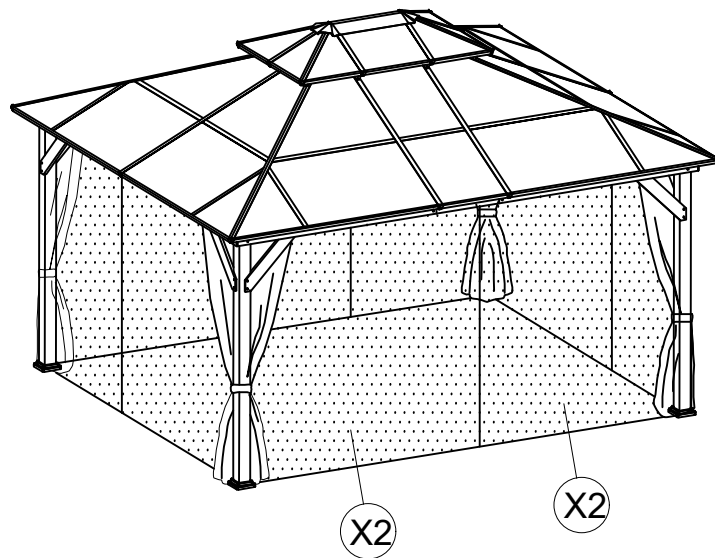
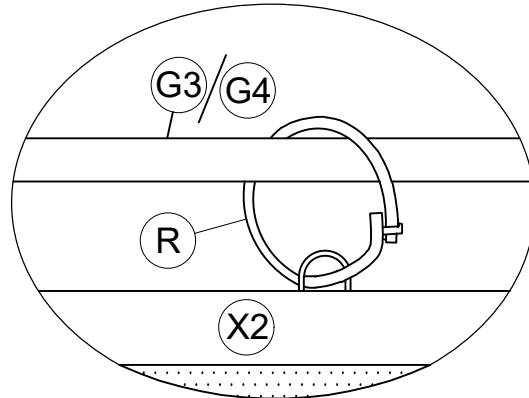



<22>

PP 8x

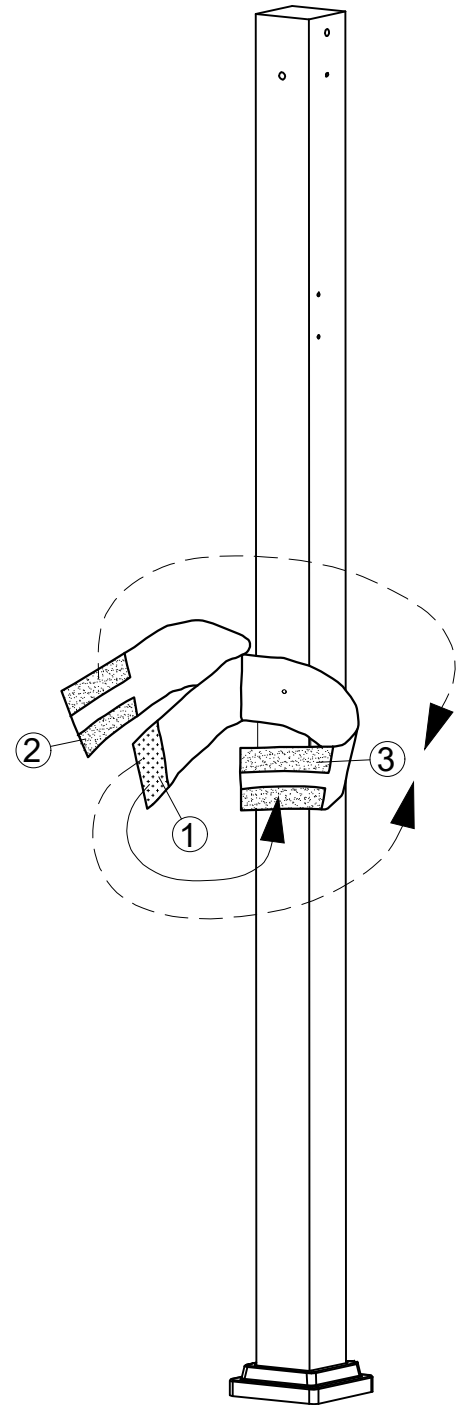
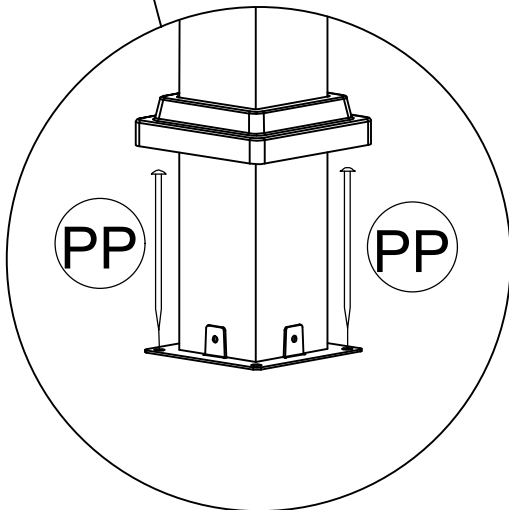
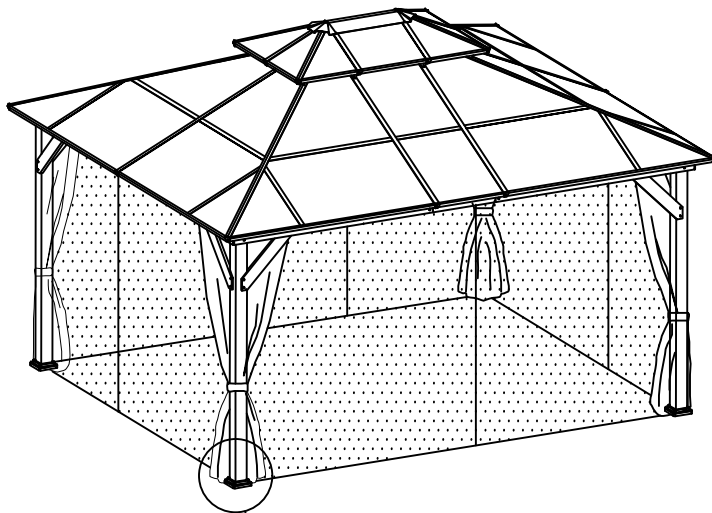

Note:

1. 1 stick 2 tie X and Y together
2. 1 stick 3 towards back tie Y
3. 1 stick 3 towards front tie X