

12 x 14 FT

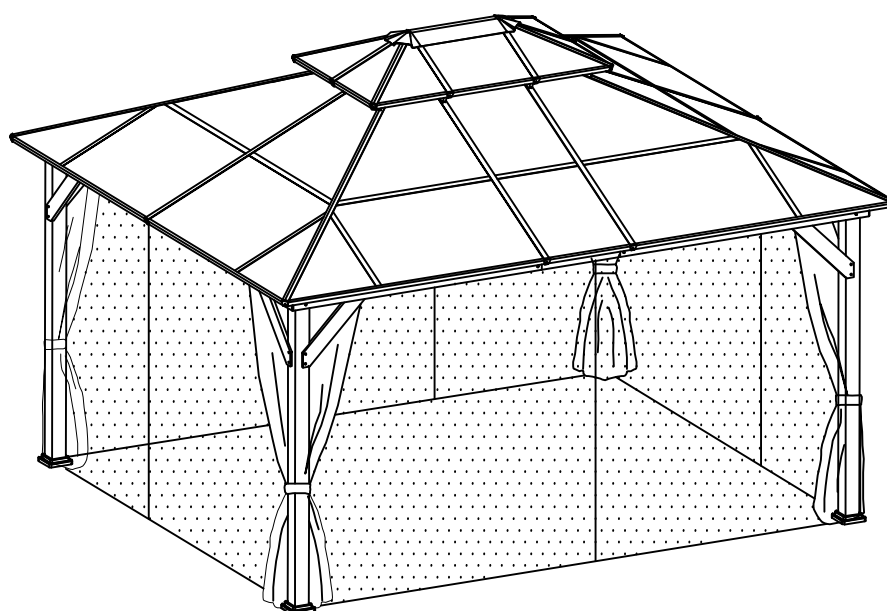

JFG016



At least need 4 people work together

REQUIRED TOOLS



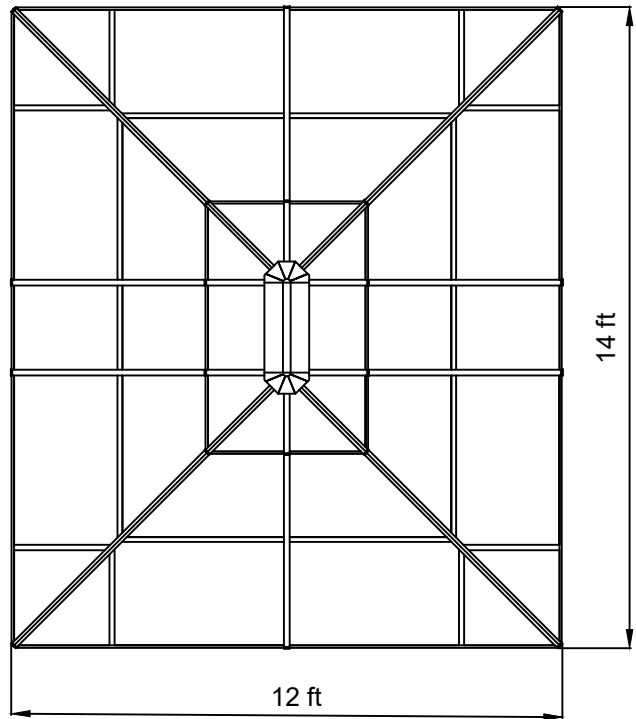
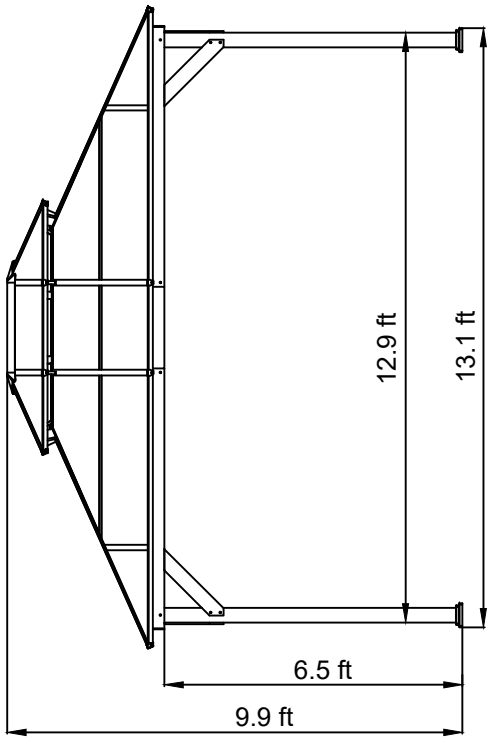
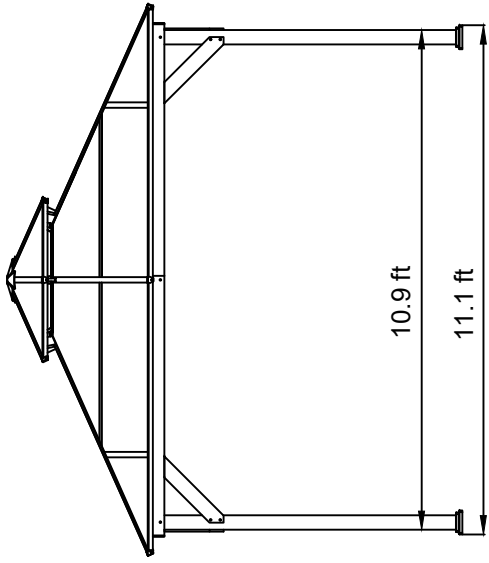

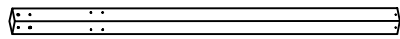

100 4x

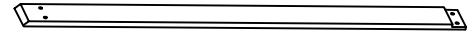

101 6x

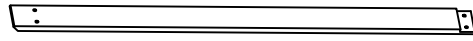

102 2x



103 4x

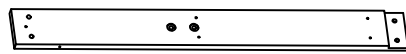

108 4x

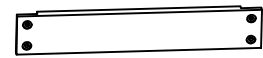

109 2x

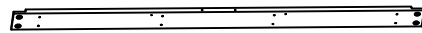

110 2x

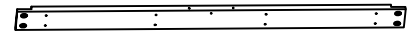

107 2x

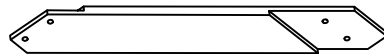

10 4x

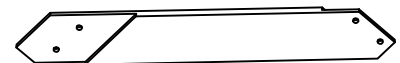

11 4x



A 4x

23-B001



B 4x

23-B002



C 6x

23-B003



D5 2x

23-B022



D1 4x

23-B005



D2 4x

23-B006



D3 4x

23-B007



D4 4x

23-B008



E9 4x

23-B023

















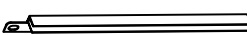

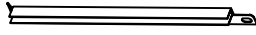
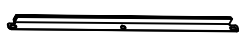

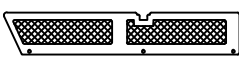

E1 4x

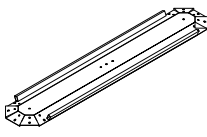
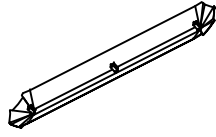
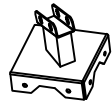



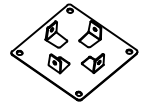

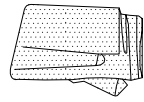

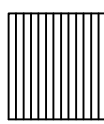
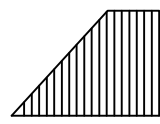
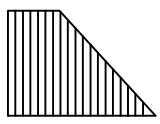
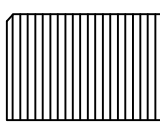
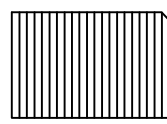
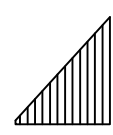
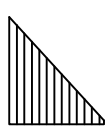
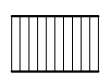
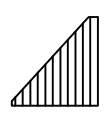
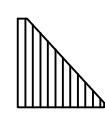

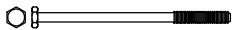

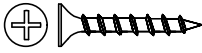

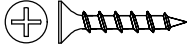

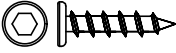

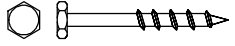

23-B010

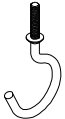
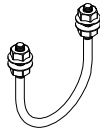

E2 4x

23-B011

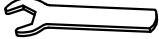
  E3 4x 23-B012	  E4 4x 23-B013	  E5 4x 23-B014	  E6 4x 23-B015
 E8 2x 23-B024	 G 4x 23-B017	 G2 4x 23-B025	 H 2x 23-B019
 H3 2x 23-B026	 H4 2x 23-B027	 L3 1x	 M3 1x
 J 4x	 K 6x	 N 12x	 N1 12x
 P 4x	 P1 4x	 X1 4x	 Y1 4x
 R 104x	 S7 4x	 S1 4x	 S2 4x
 S3 4x	 S4 4x	 S5 4x	 S6 4x
 T3 2x	 T1 4x	 T2 4x	

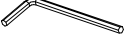
 M10*160 (AA) 8x	 M6 (BB) 16x	 M5*40 (CC) 72x	 M6 (DD) 18x
 M5*30 (EE) 54x	 M8*35 (HH) 16x	 M8*35 (II) 16x	 M8*25 (KK) 28x
 M10 (LL) 8x	 M8 (MM) 16x	 M10 (NN) 24x	 M10*80 (OO) 8x
 M6x15 (QQ) 58x	 M5x15 (SS) 12x	 M6x35 (TT) 8x	 (ZZ) 2x
 (VV) 1x	 M6x10 (XX) 10x	 (PP) 8x	 M3 Drill (RR) 2x
 M6 (Z1) 2x	 M10 (Z4) 2x	 M8 (Z2) 2x	 M6 (Z5) 2x

<1>

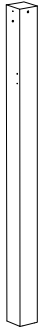

100 4x

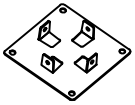

P 4x



P1 4x



M5*30

EE 16x

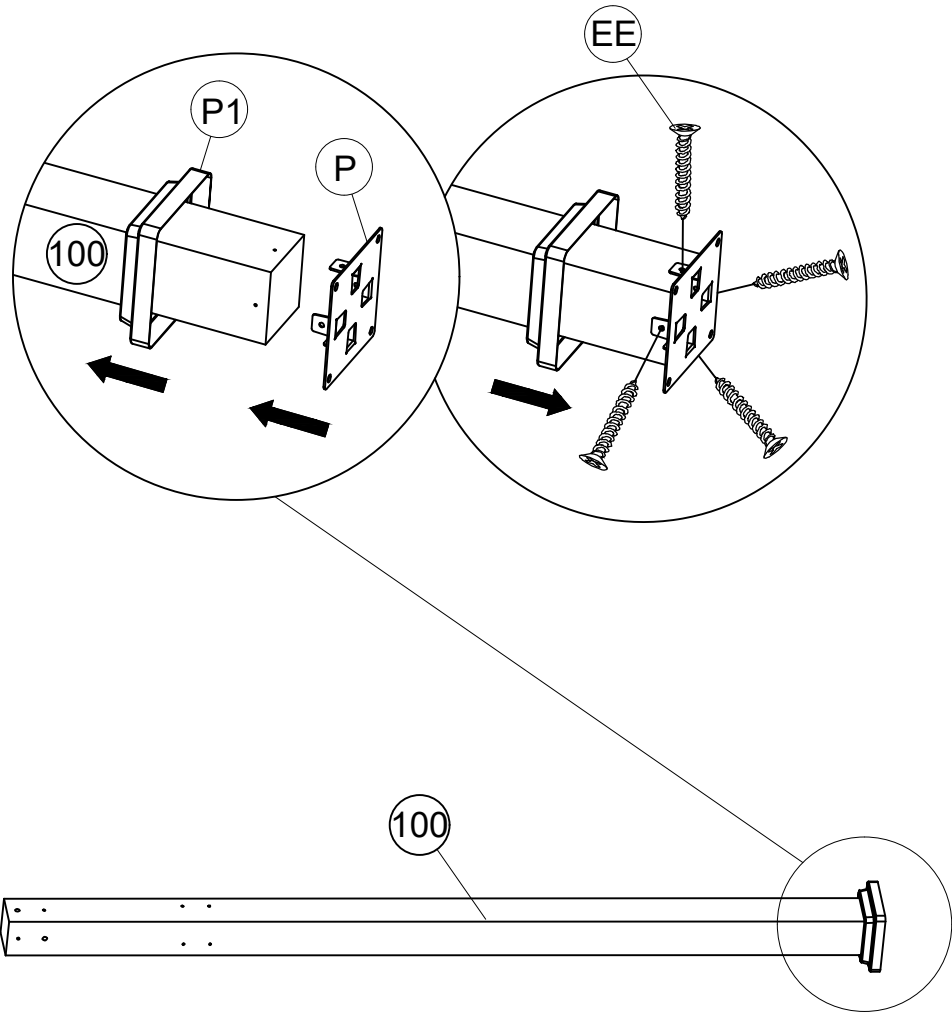

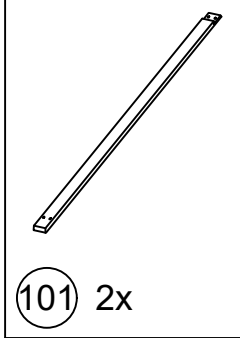

101 2x

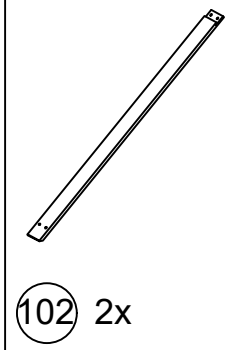

102 2x

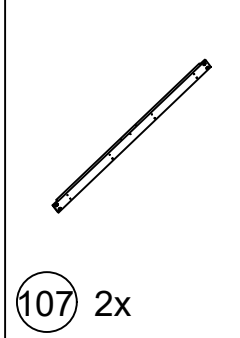

107 2x

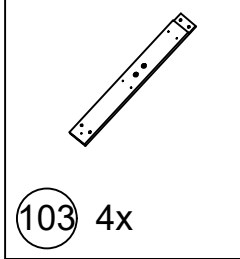

103 4x

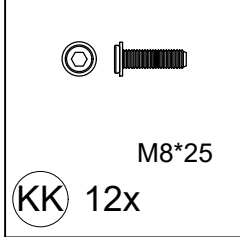

M8*25

KK 12x

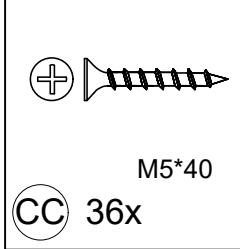

M5*40

CC 36x

<2>

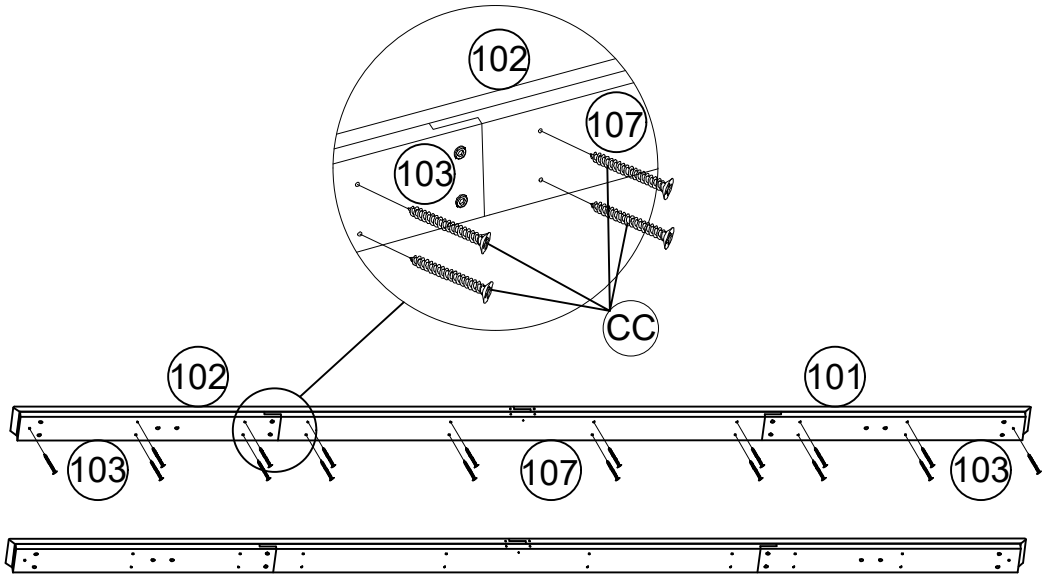
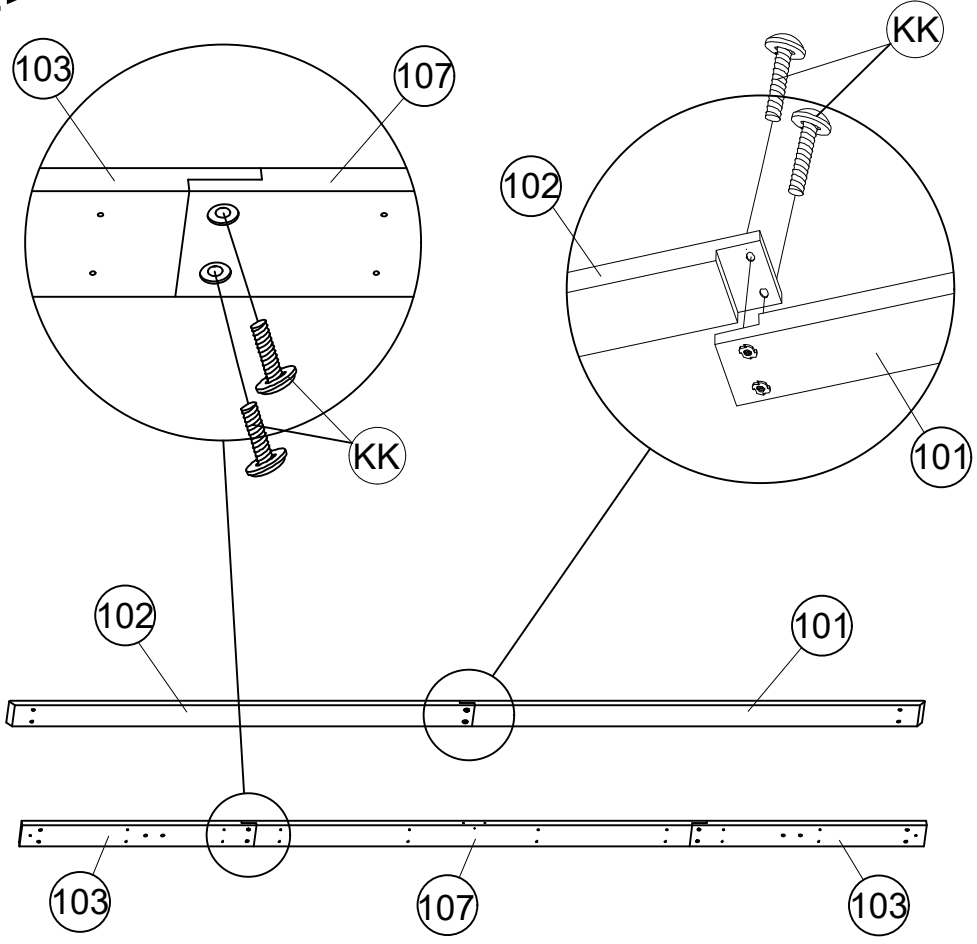

Connect the outer beams (102,101) and inner beams (103,107) separately with screw KK, and then combine the outer beams and inner beams together with self-tapping screw CC.

Attention:

Pay attention to the side of Beam (102) and Beam (101) when join them with Beam (107) and Beam (103) .

8

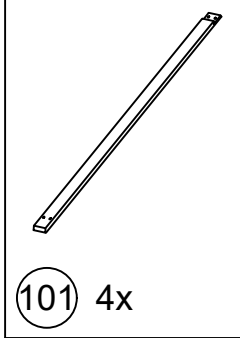

101 4x

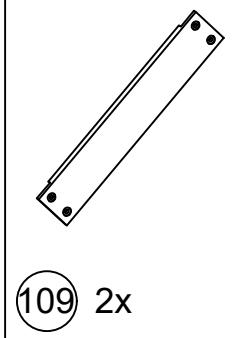

109 2x

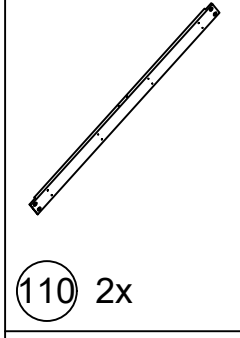

110 2x

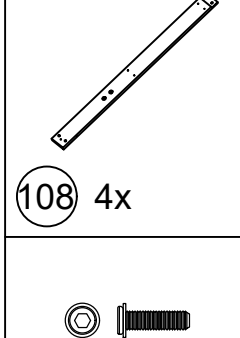

108 4x

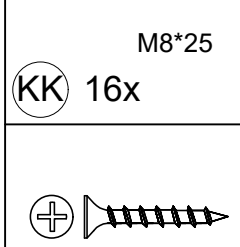

M8*25
KK 16x

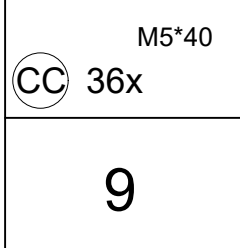

M5*40
CC 36x

9

<3>

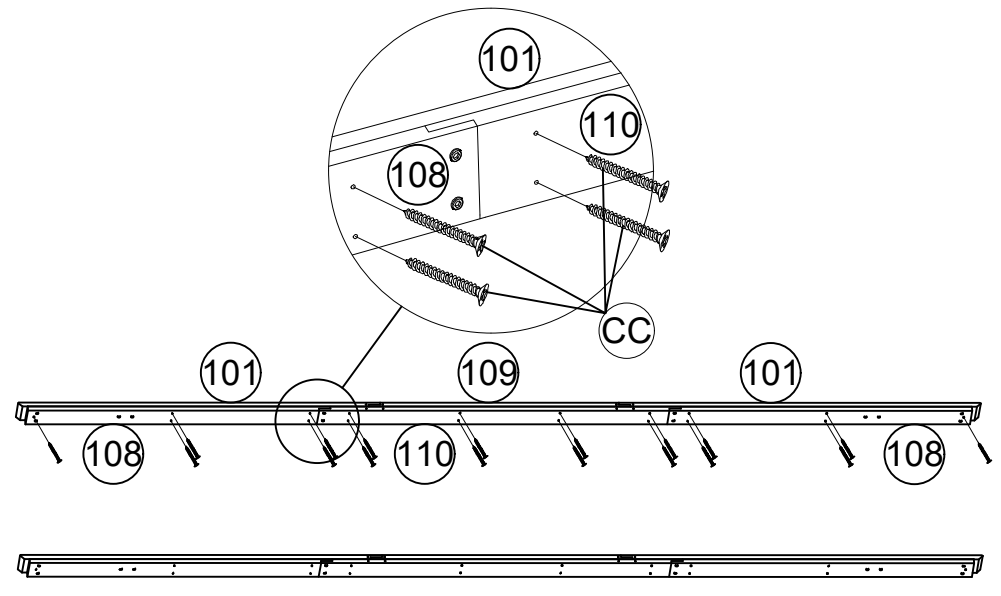
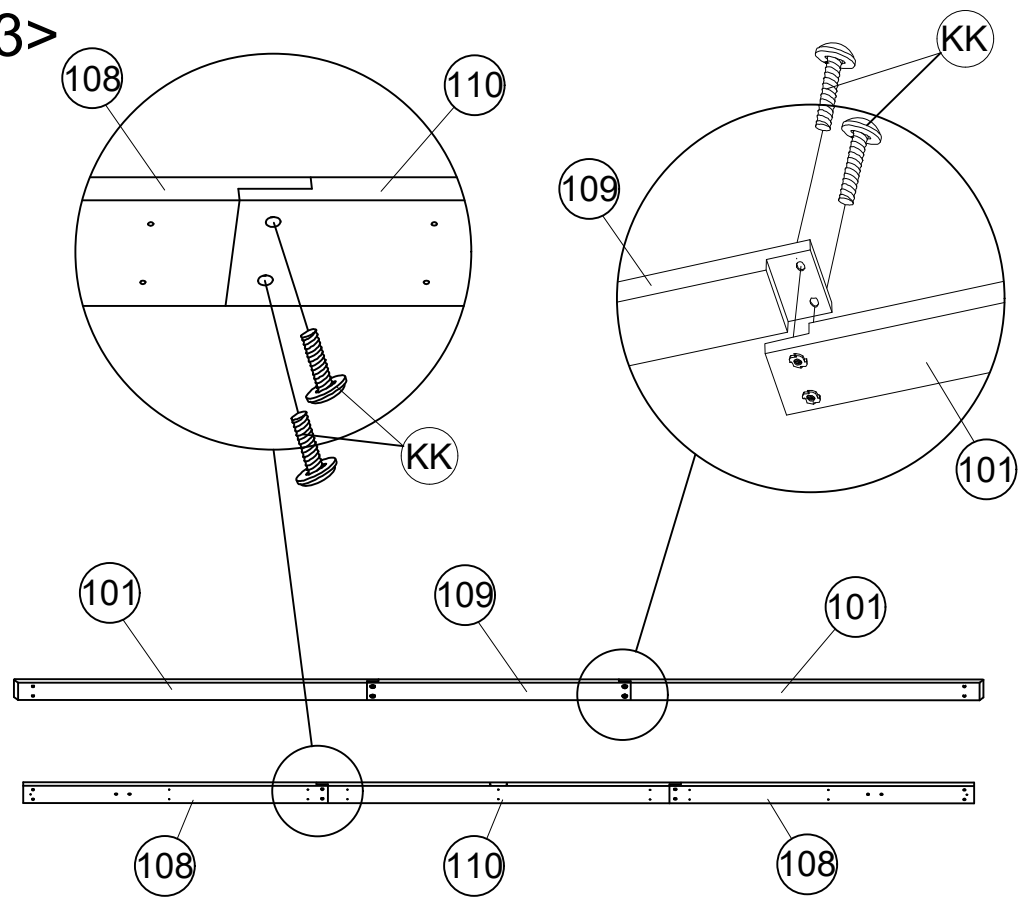

Connect the outer beams (101,109) and inner beams (108,110) separately with screw KK, and then combine the outer beams and inner beams together with self-tapping screw CC.

Attention:

Pay attention to the side of Beam (101) and Beam (109) when join them with Beam (110) and Beam (108) .

<4>

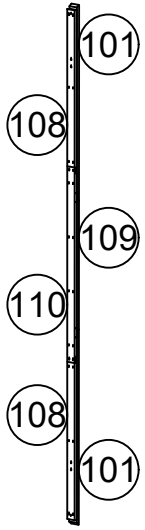

2x

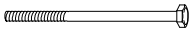

M10*165

AA 4x

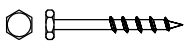

M10*80

OO 4x



M10

NN 12x



M10

LL 4x

10

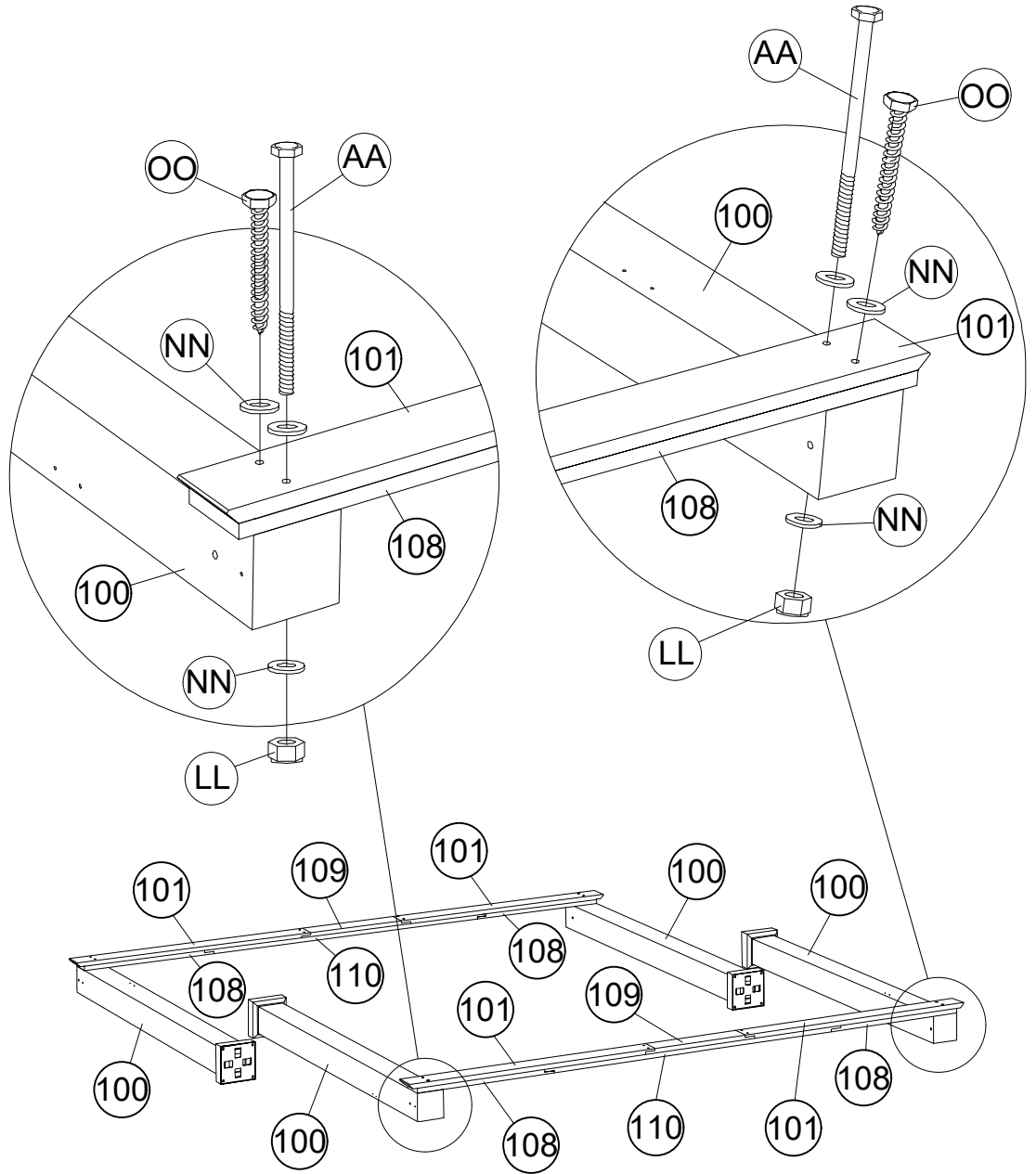

<5>

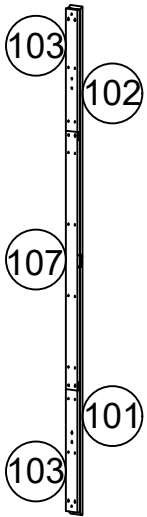

2x

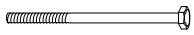

M10*165

AA 4x

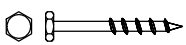

M10*80

OO 4x



M10

NN 12x



M10

LL 4x

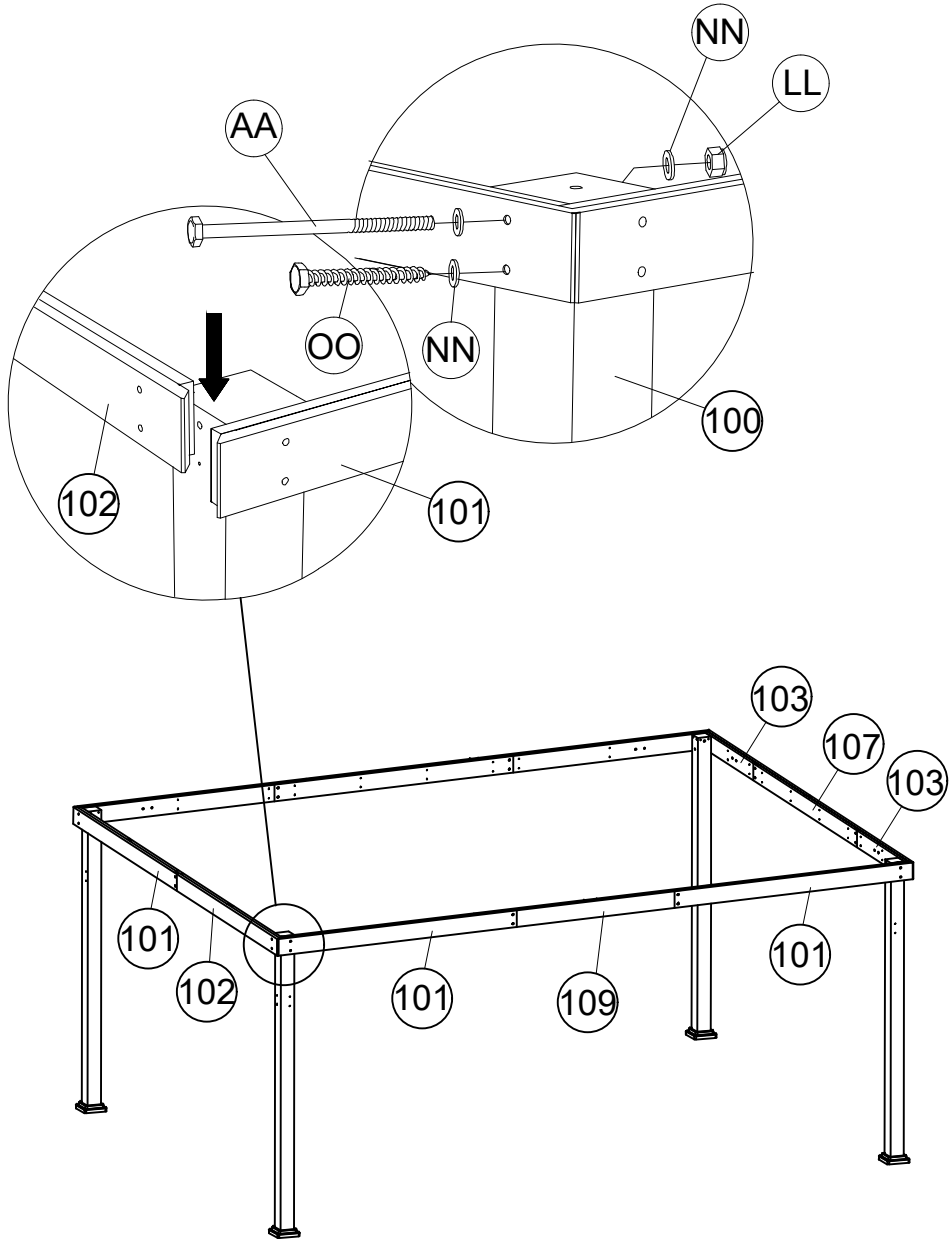

11

<6>

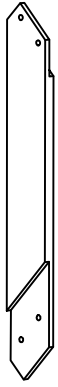

10 4x

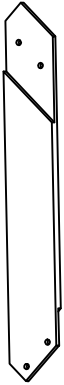

11 4x



M8*35

HH 16x

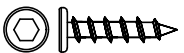

M8*35

II 16x



M8

MM 16x

I d1=d2

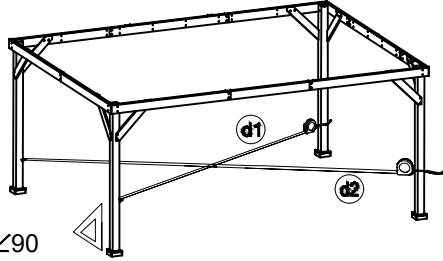

Rt ∠90

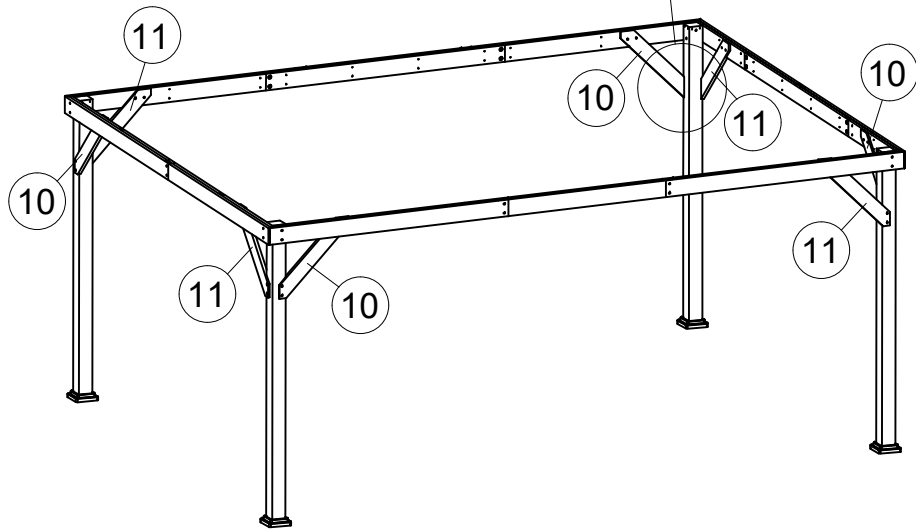
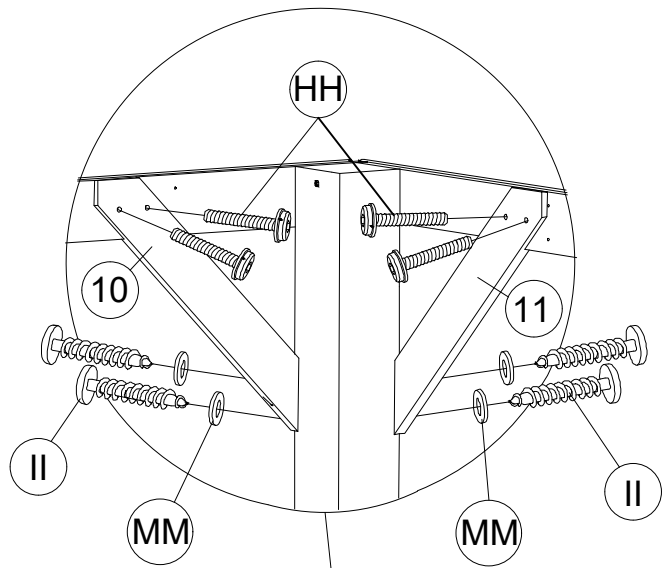

12



J 4x

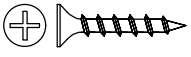

M5*30

EE 16x

<7>

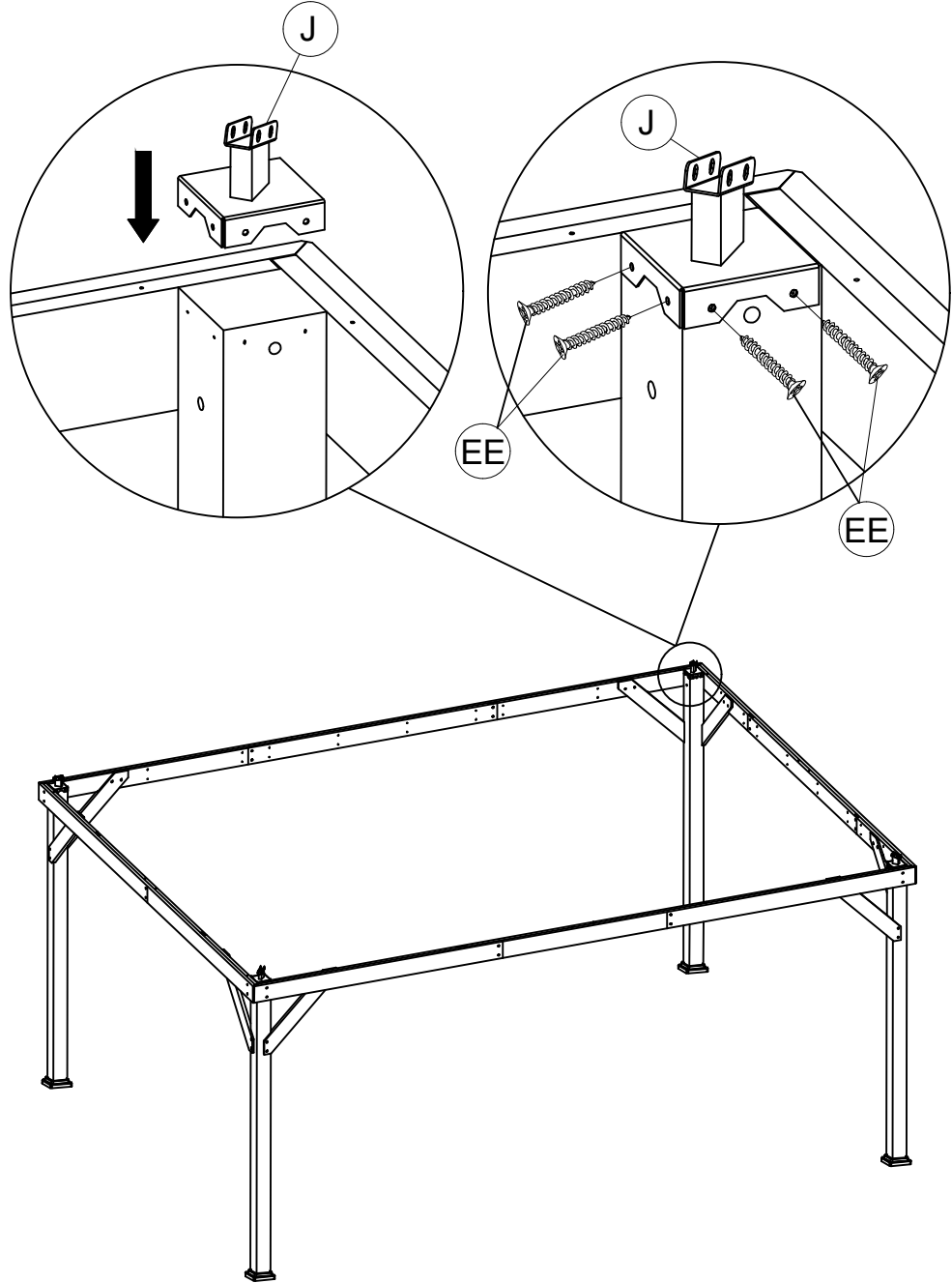

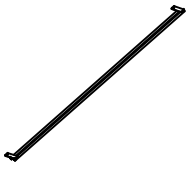

G 4x



G2 4x



M5*30

EE 16x

<8>

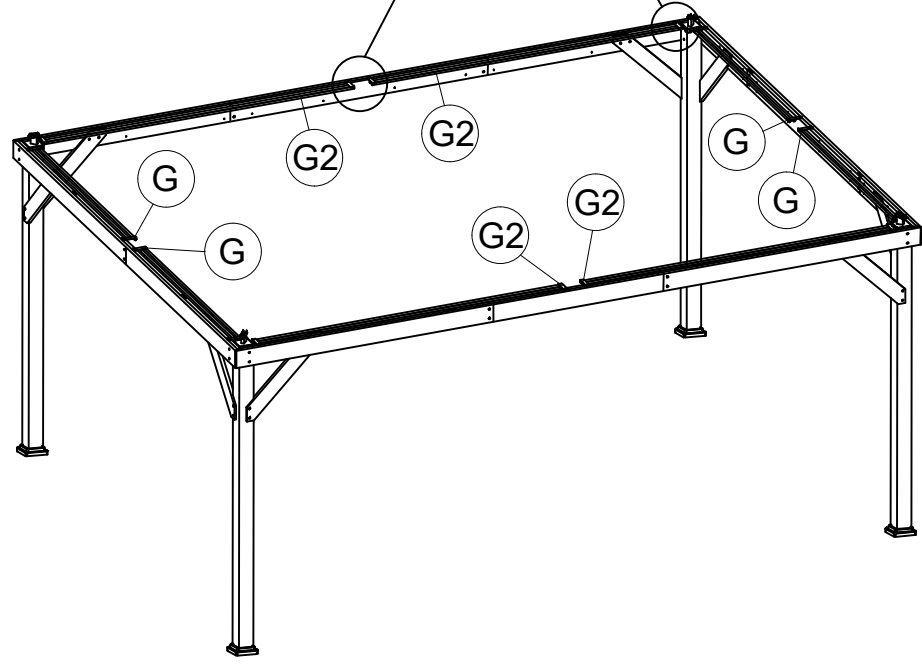
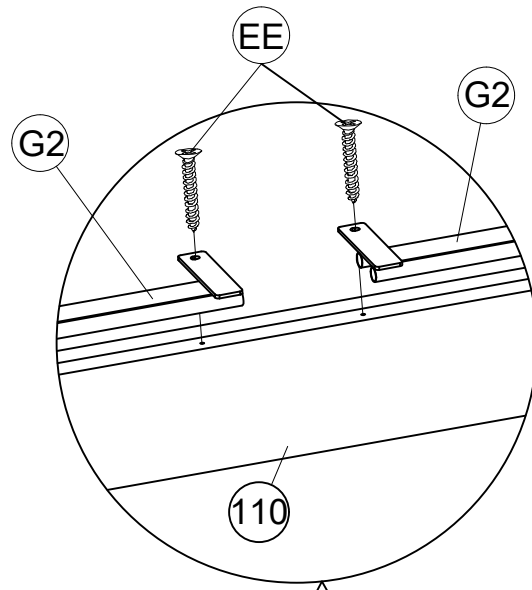

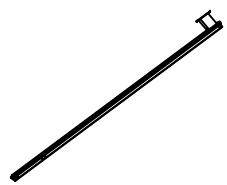

A 4x



B 4x

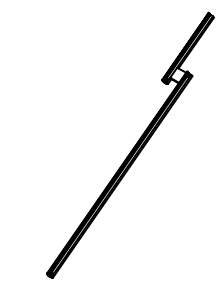

C 6x

<9>

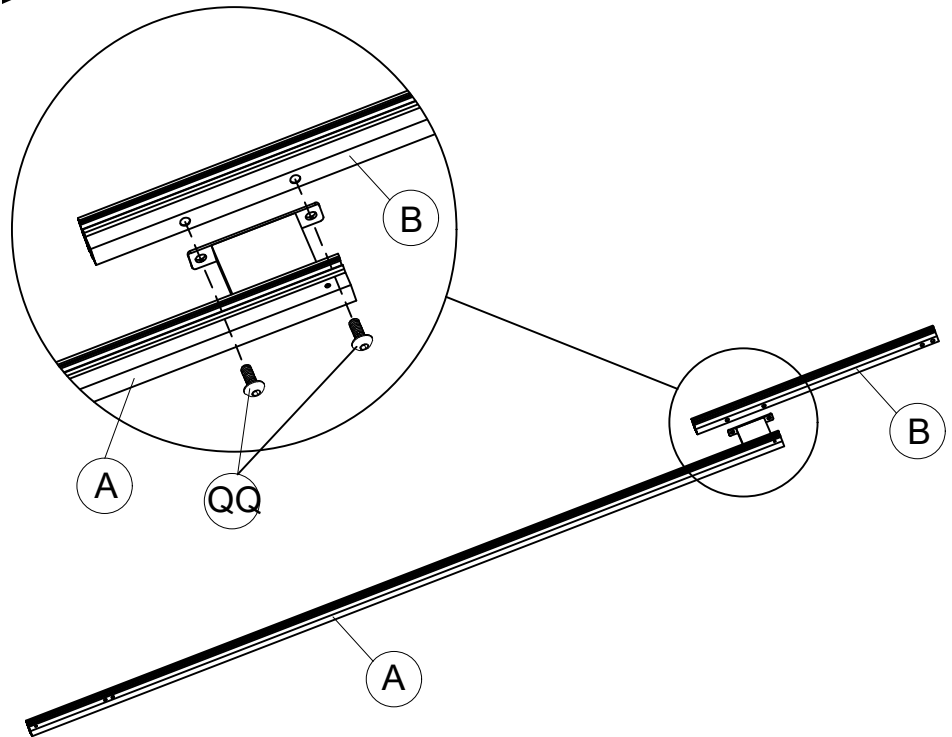

K 6x



QQ 8x
M6x15



SS 12x
M5x15

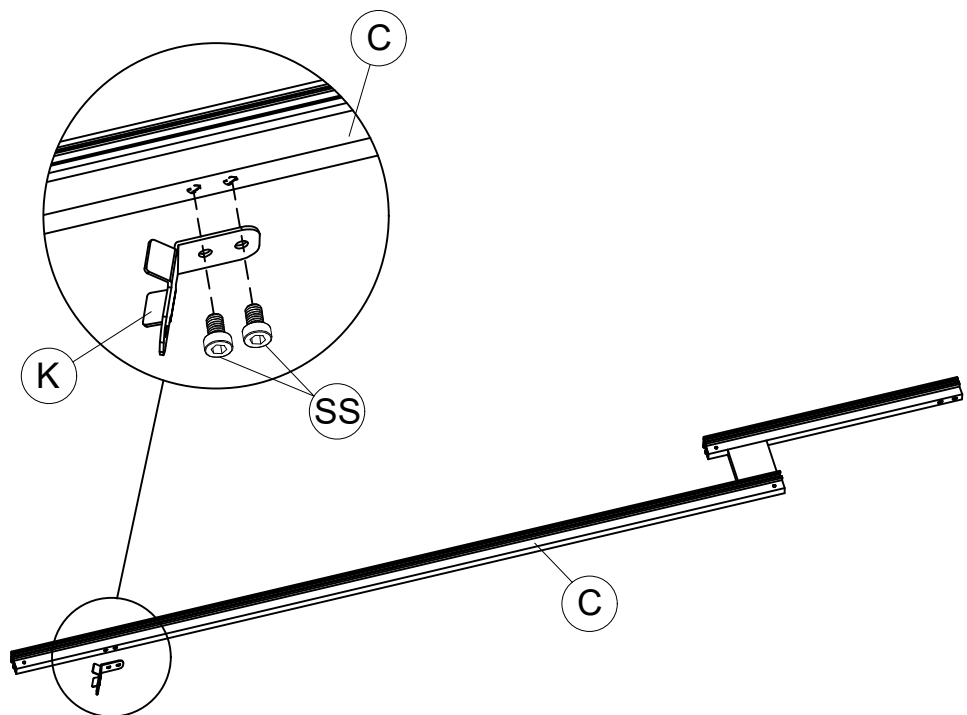

15

<10>

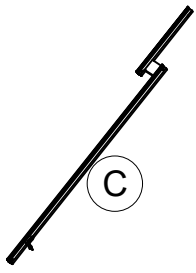

4x

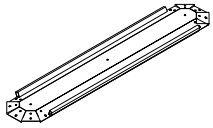

L3 1x



M6x15

QQ 8x

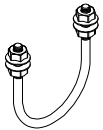

VV 1x

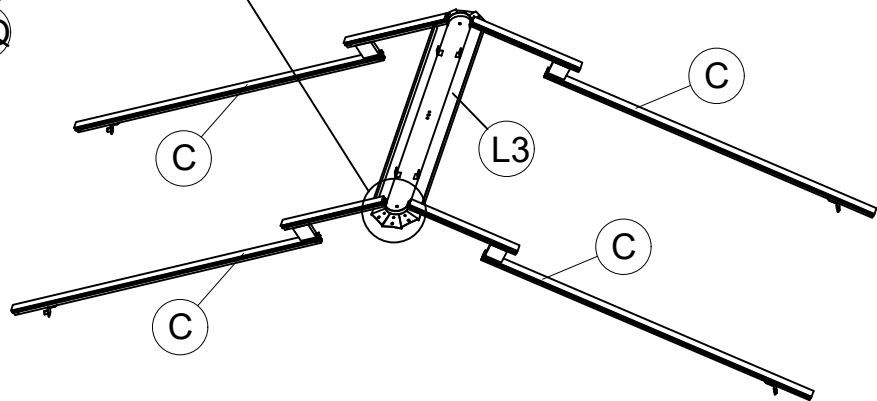
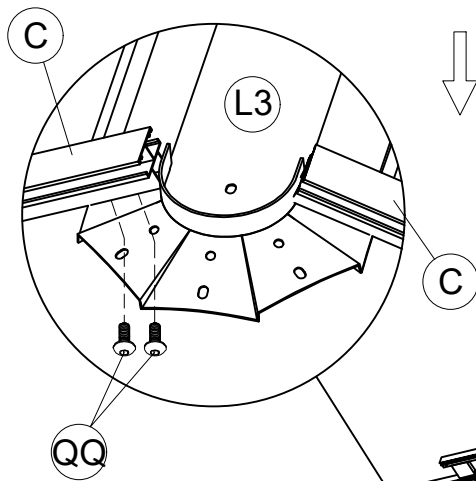
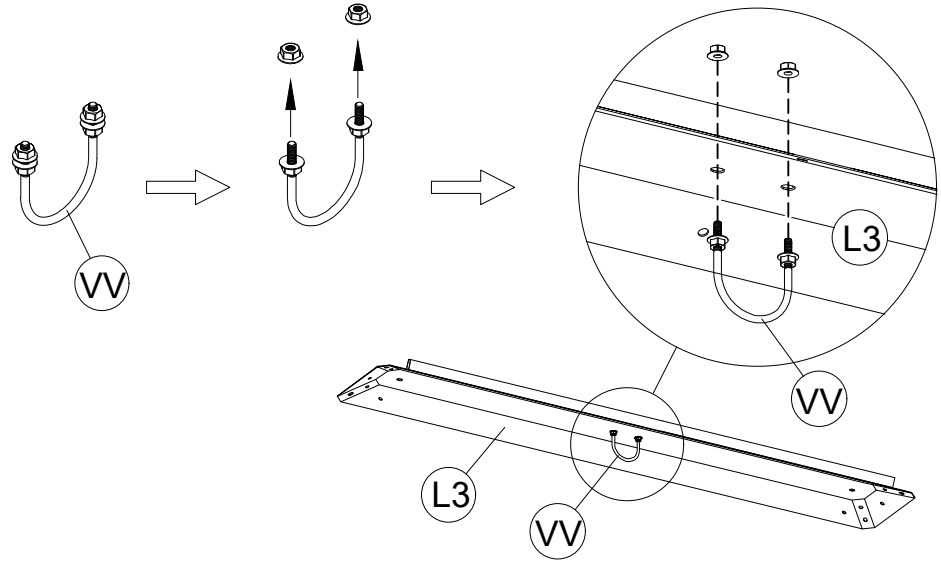

16

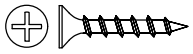

M5*30

EE 4x

<11>

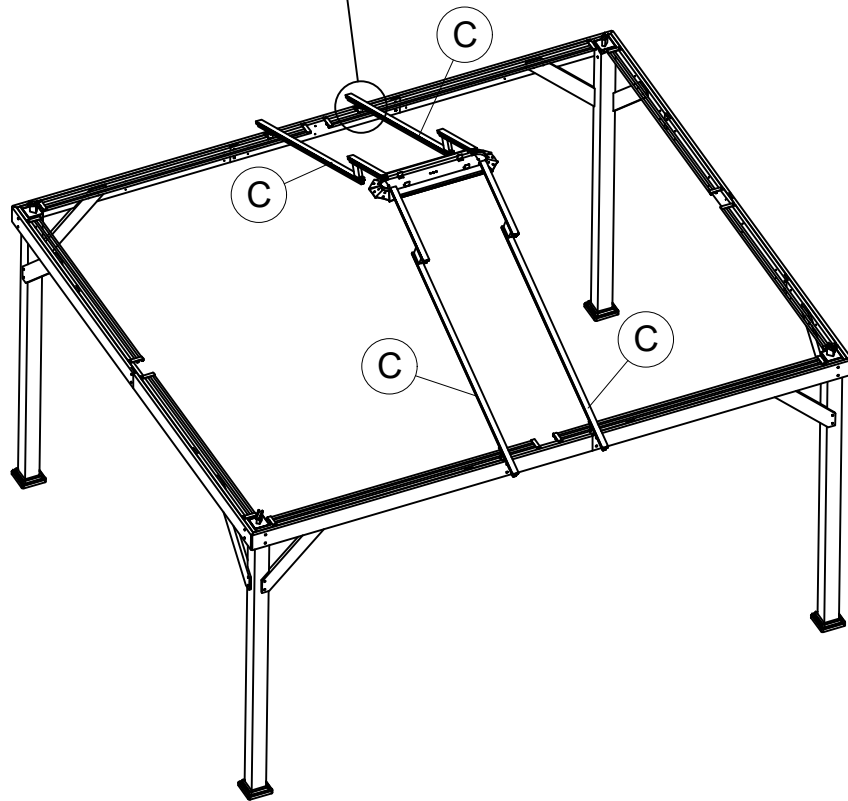
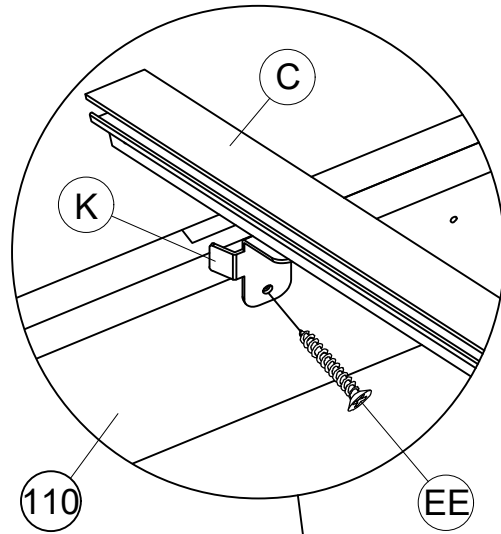

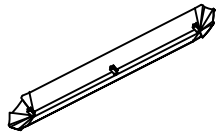

M3 1x



ZZ 2x

<13>

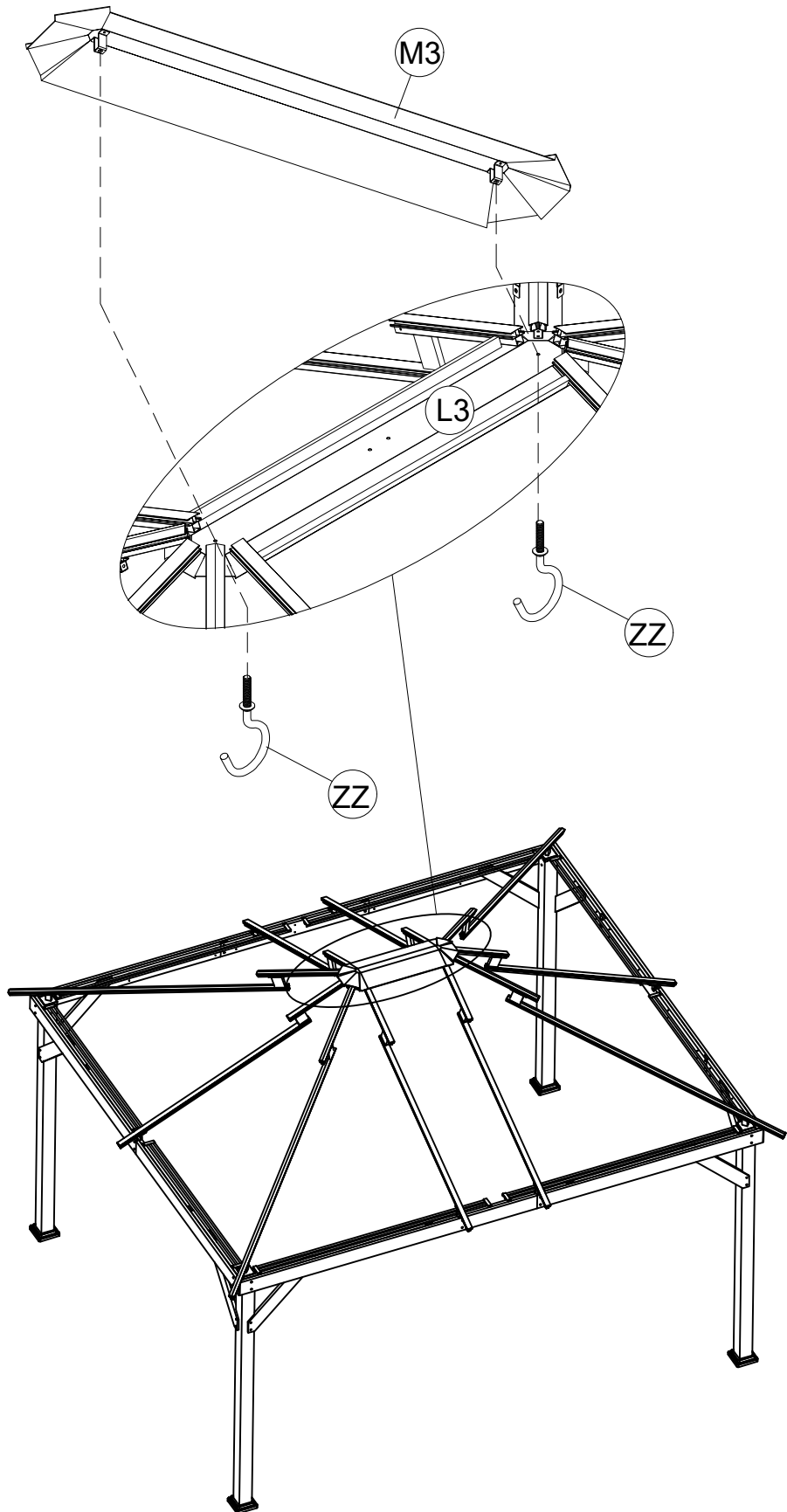



T1 4x



T2 4x

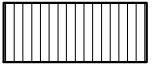

T3 2x

<14>

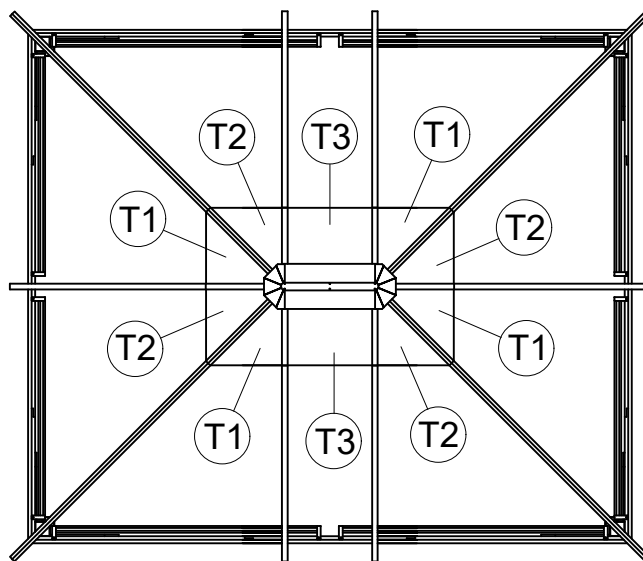
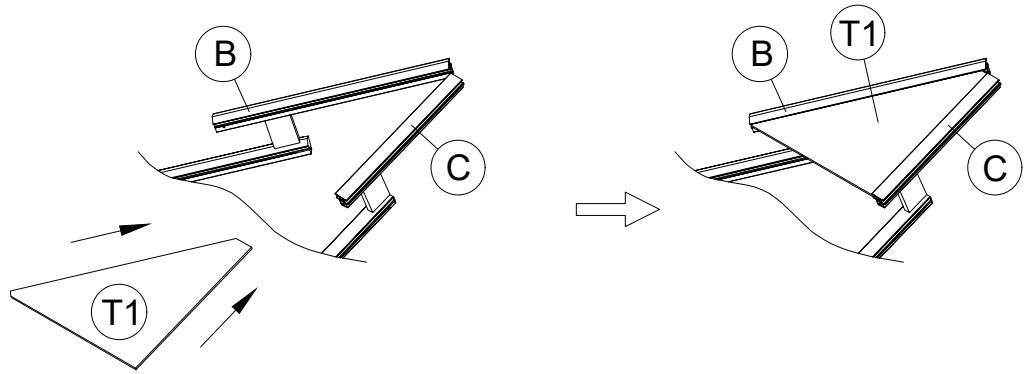
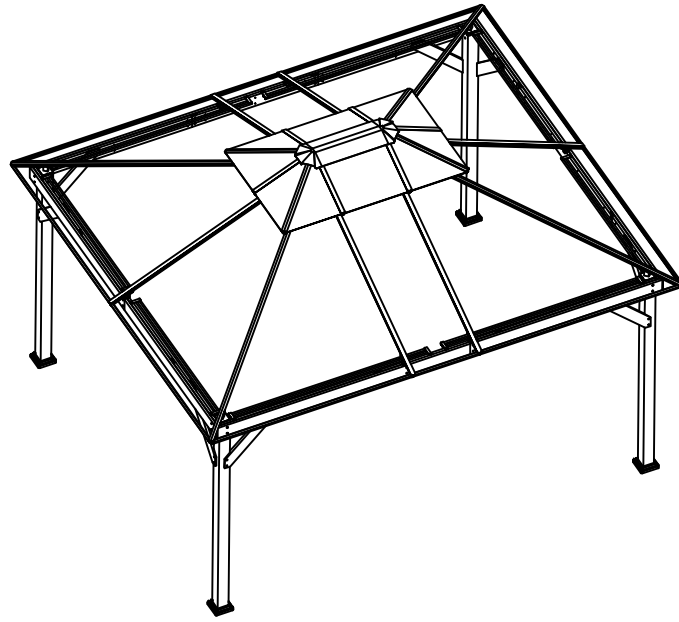

<15>

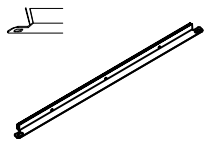

E9 2x



E3 4x

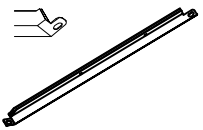

E4 4x



N 4x



N1 6x



QQ M6x15
10x

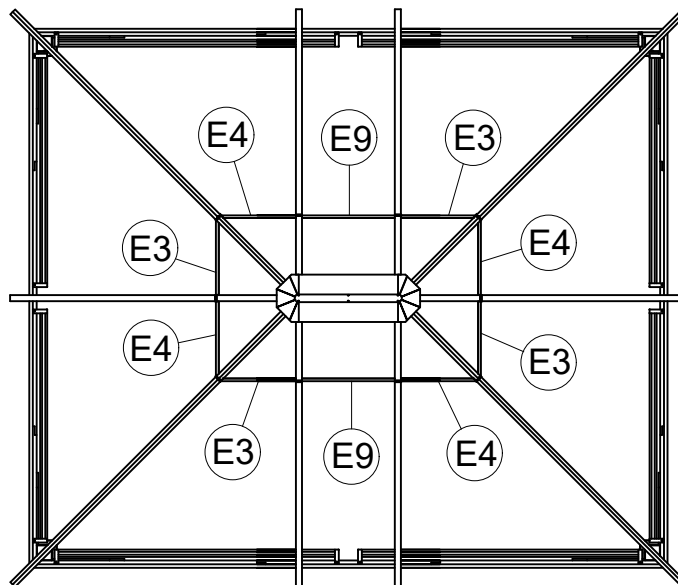
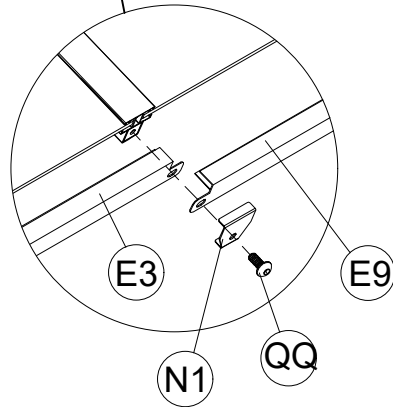
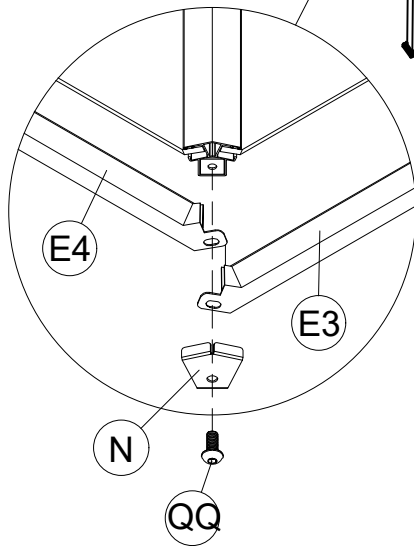
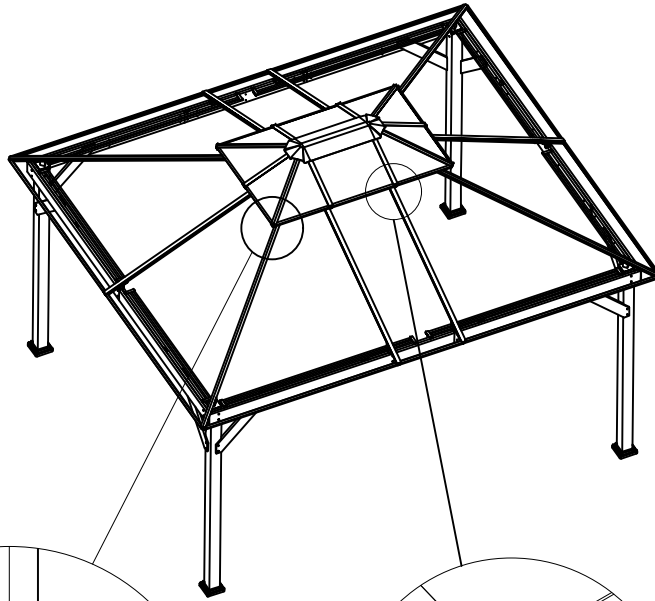

<16>

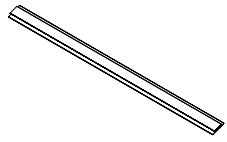

D5 2x

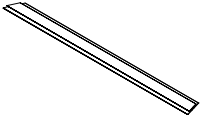

D1 4x

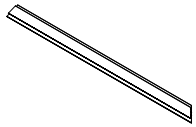

D2 4x

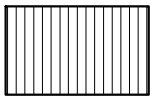

S7 2x

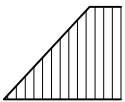

S1 4x

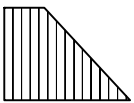

S2 4x

22

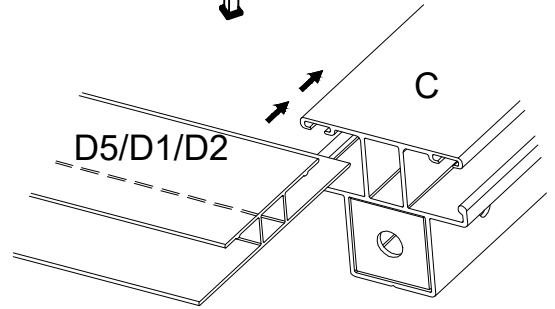
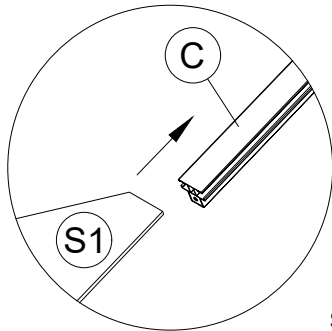
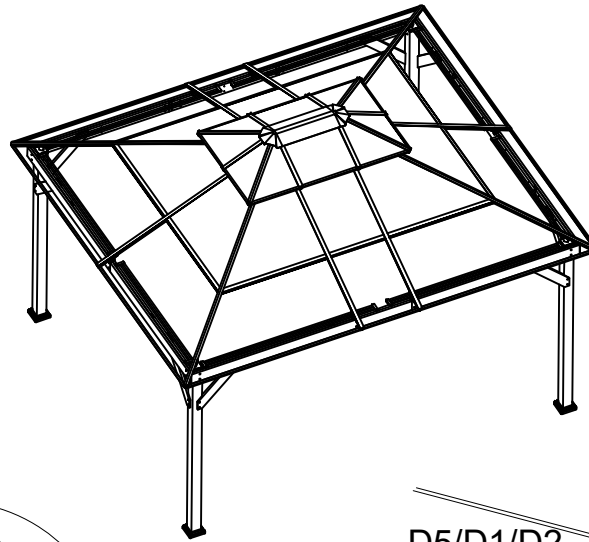

Note:

When D1 or D2 or D5 slide into the C, the wide side must be face down and narrow side face up, otherwise will cause water leaking

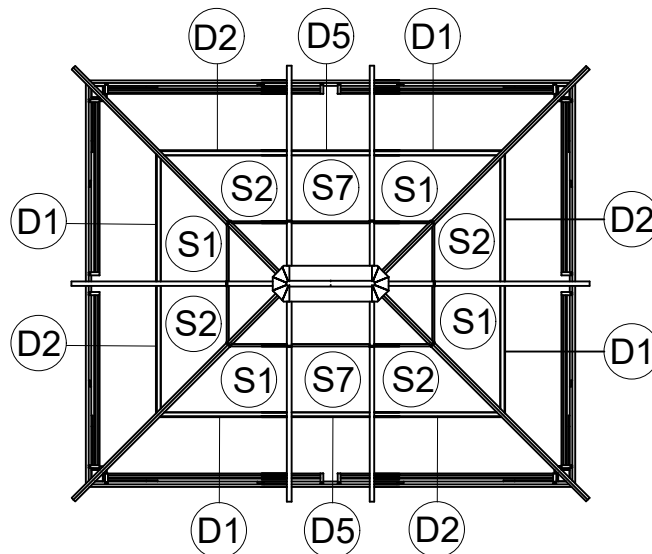
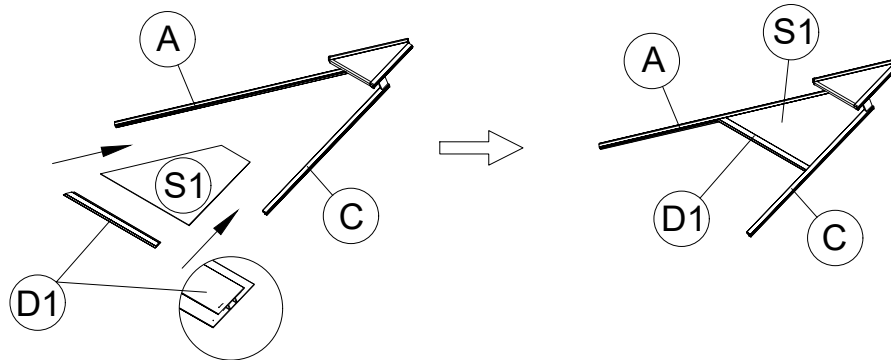

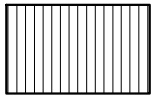

S7 2x

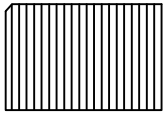

S3 4x

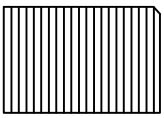

S4 4x

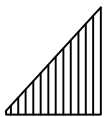

S5 4x

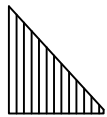

S6 4x



D3 4x

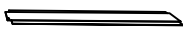

D4 4x

23

<17>

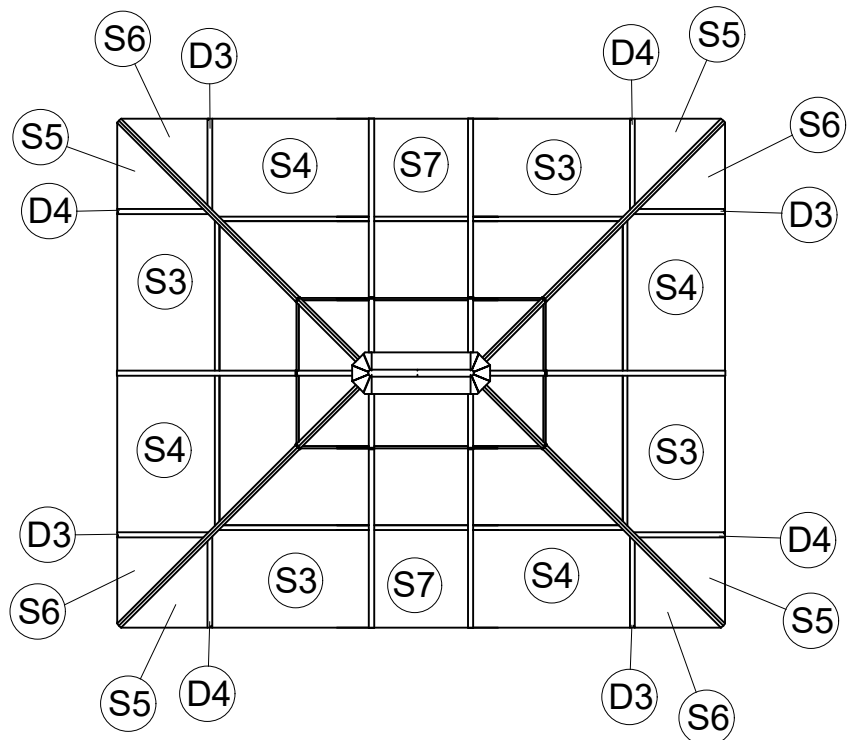
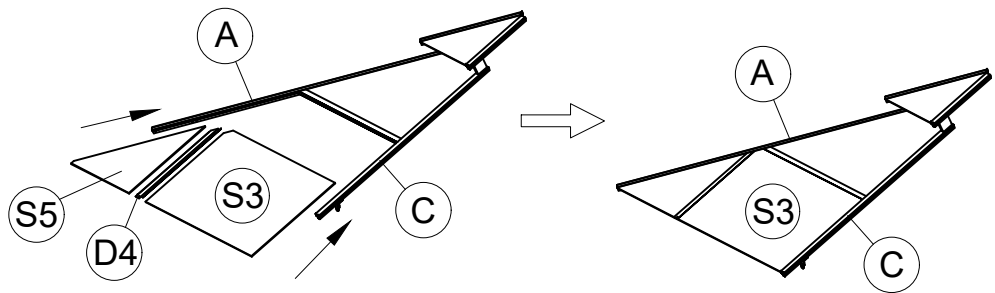
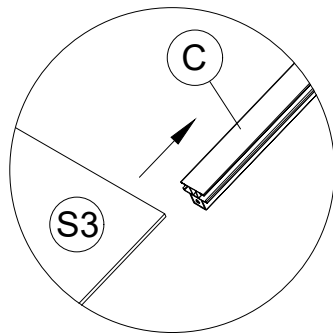
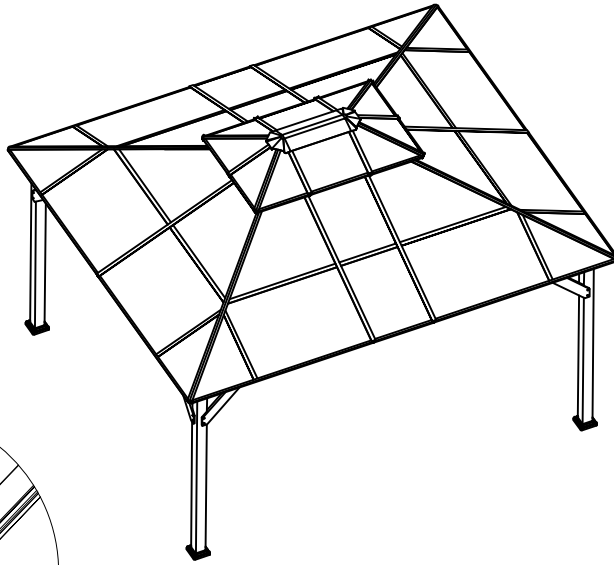

<18>

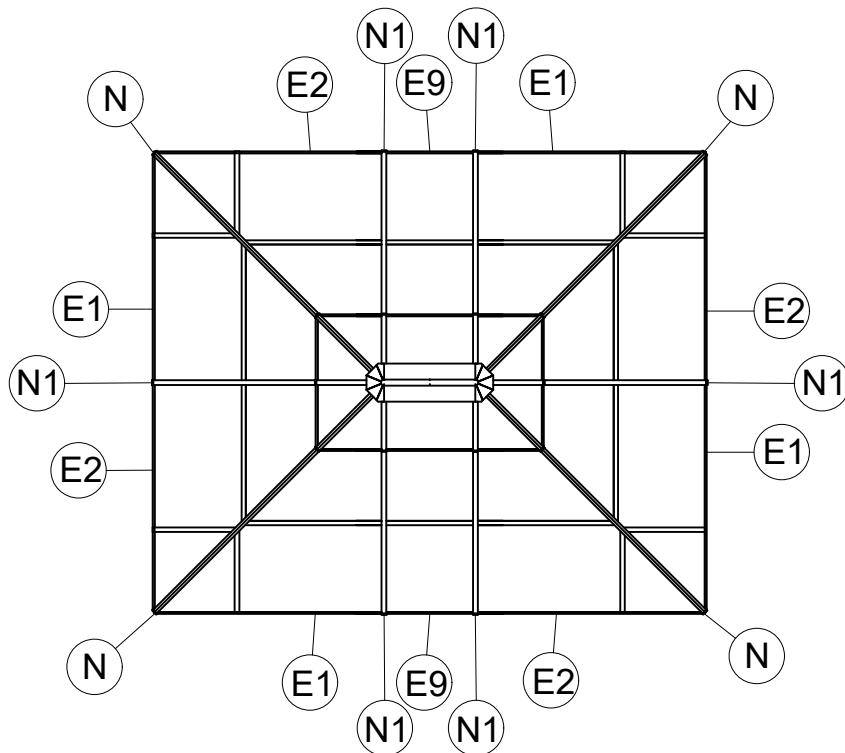
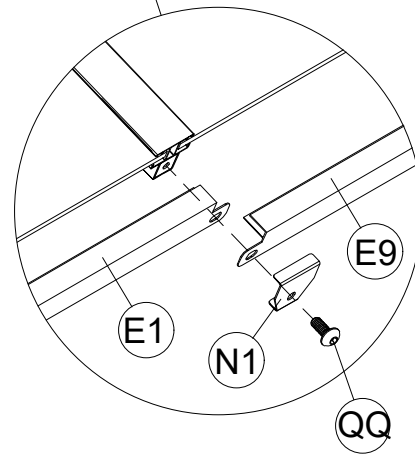
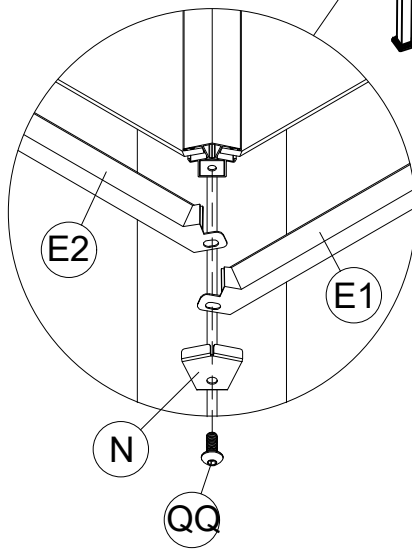
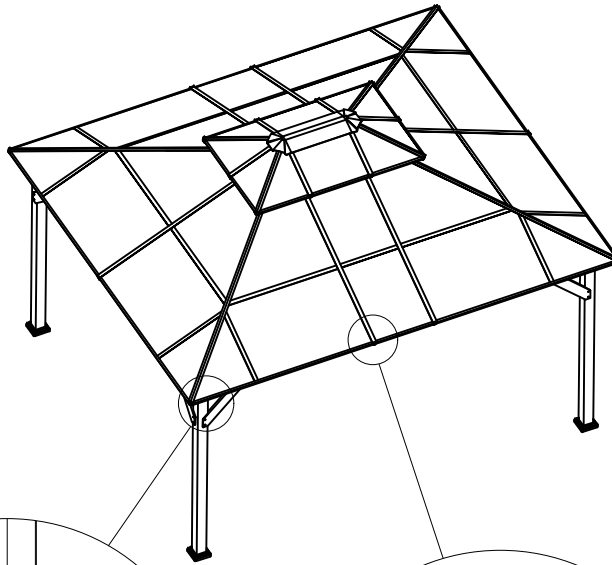

E9 2x

E1 4x







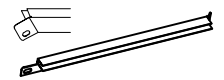

E2 4x

N 4x

N1 6x

QQ 10x
M6x15

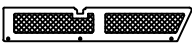
24

-  **E8** 2x
-  **E5** 4x
-  **E6** 4x
-  **N** 4x
-  **QQ** 10x
M6x15
-  **H** 2x
-  **H3** 2x
-  **H4** 2x
-  **XX** 10x
M6x10
-  **DD** 10x
Nut M6

<19>

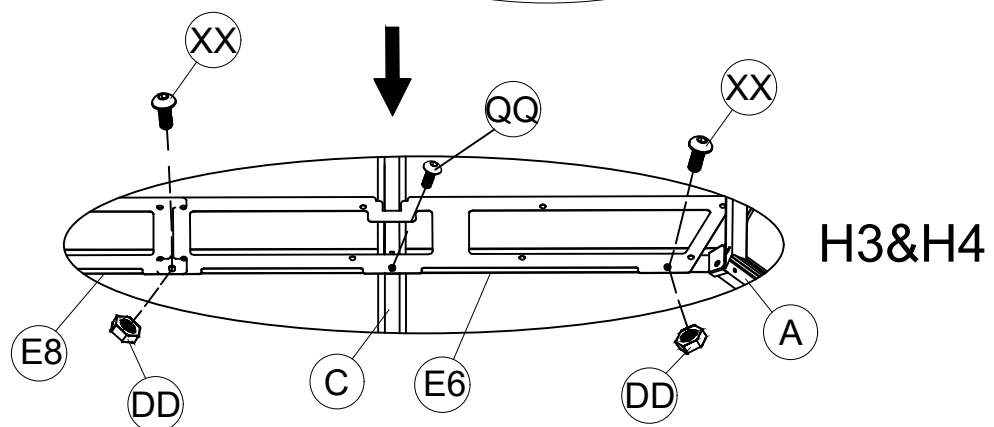
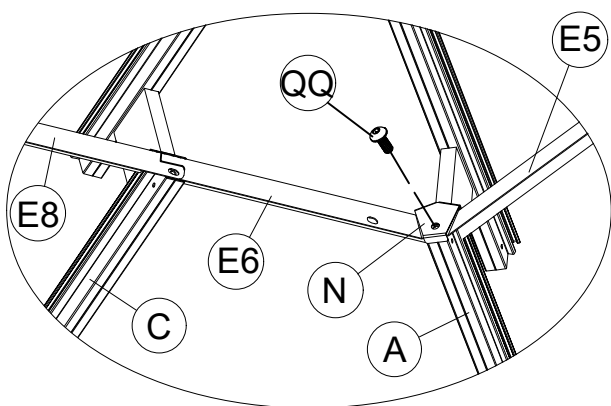

H3&H4

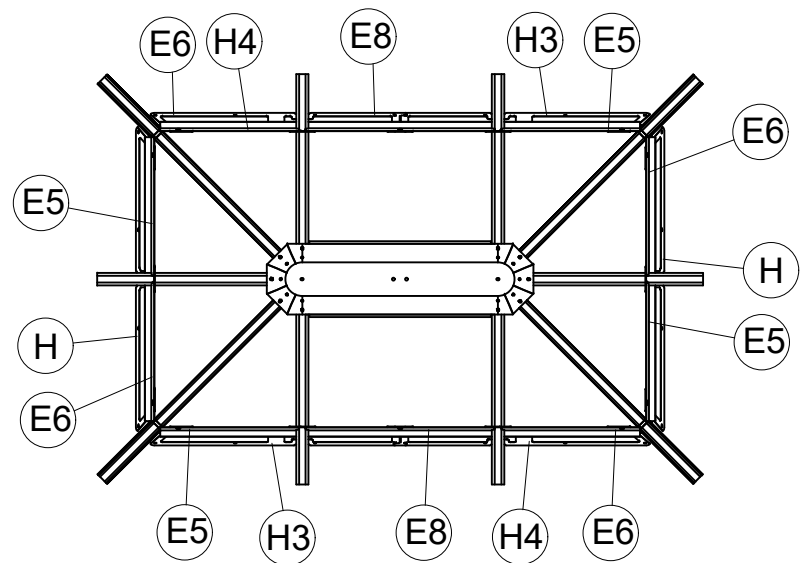
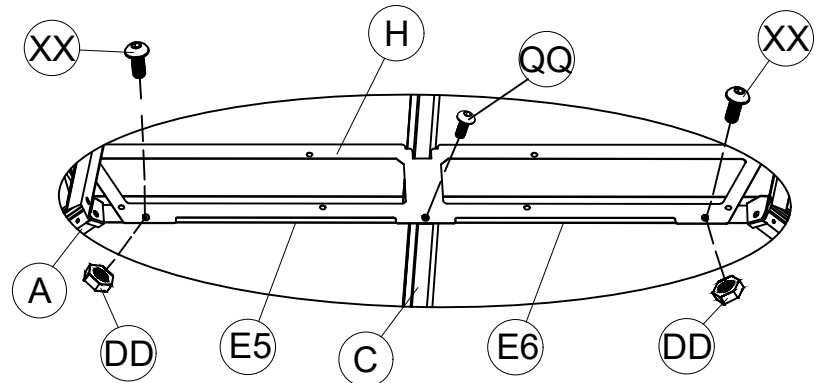

Upward view of the roof

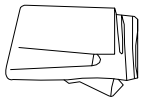

<20>

Y1 4x



R 52x

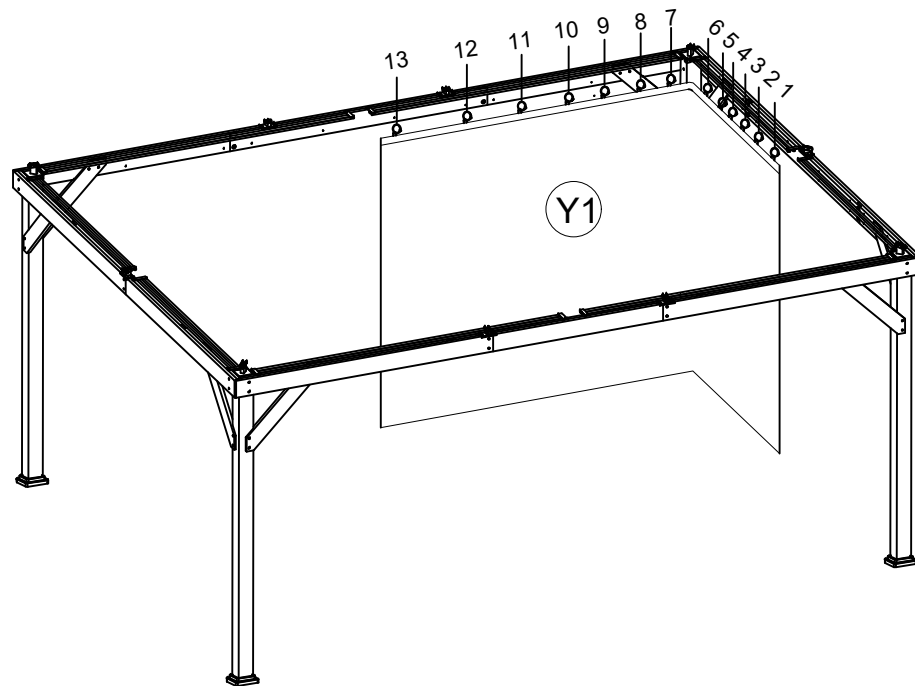
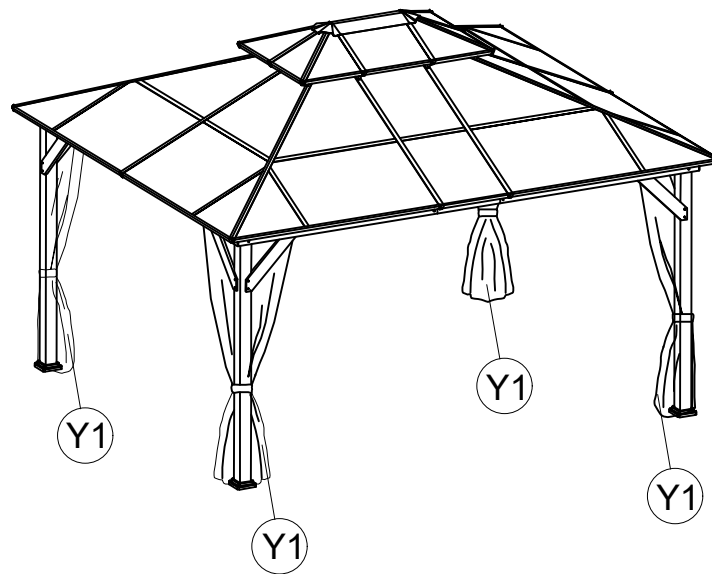
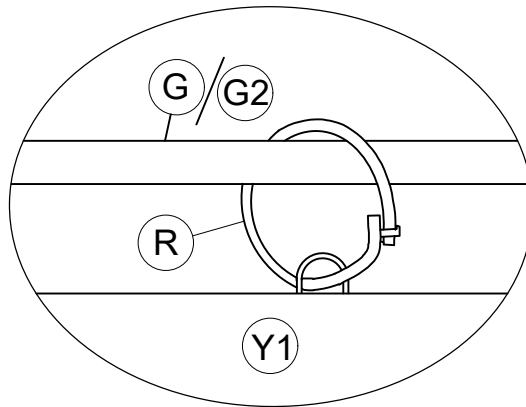

26

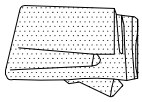

<21>

X1 4x



R 52x

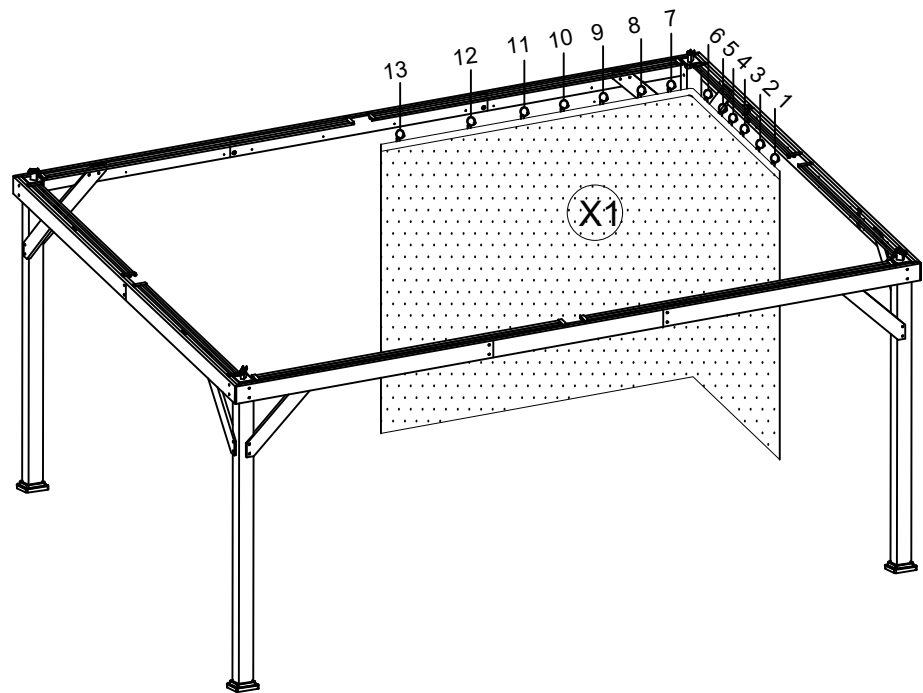
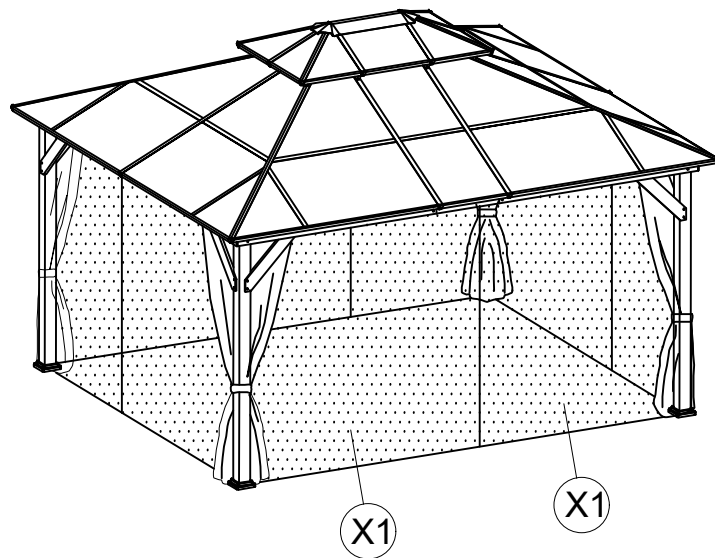
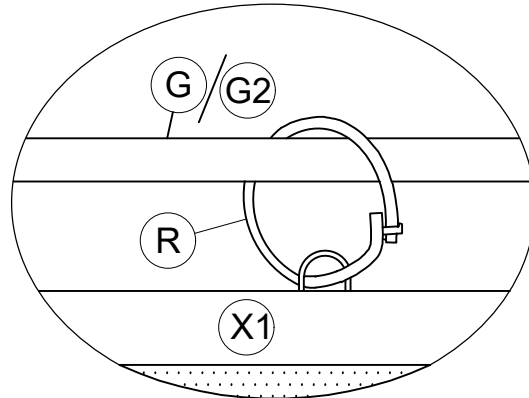



<22>

PP 8x

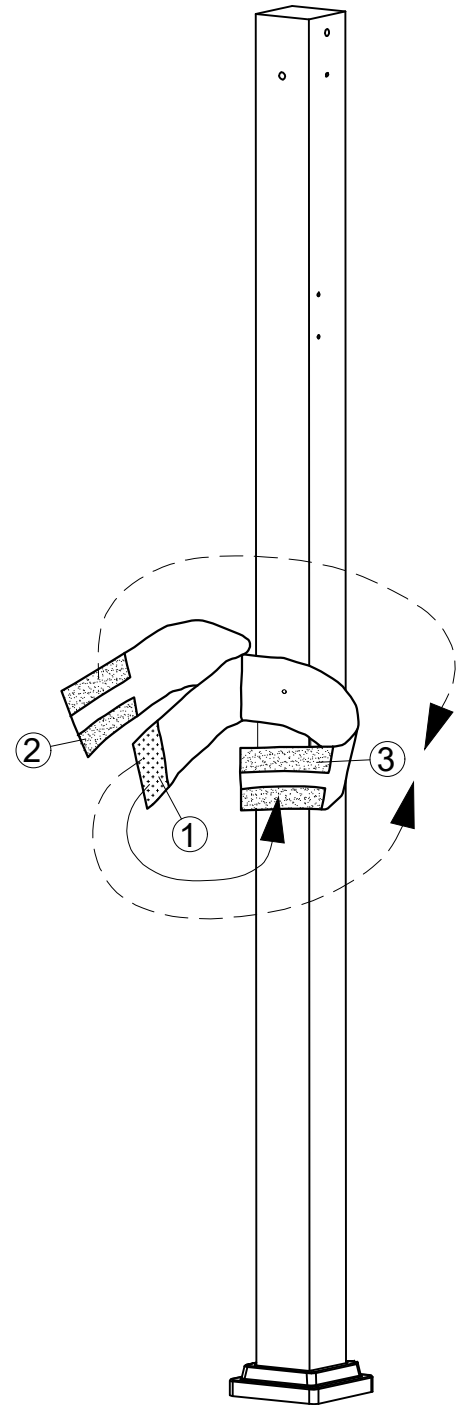
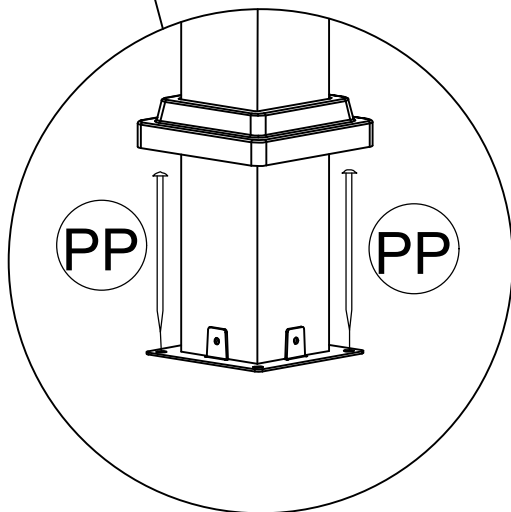
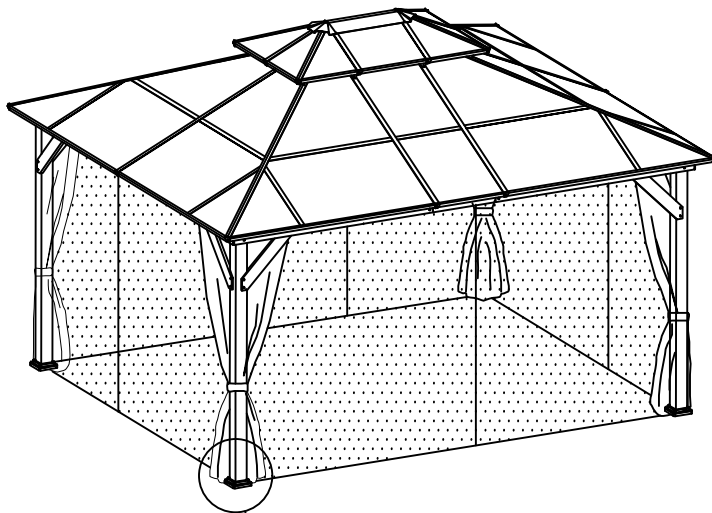

Note:

1. 1 stick 2 tie X and Y together
2. 1 stick 3 towards back tie Y
3. 1 stick 3 towards front tie X