

12 x 12 FT

□ □ □ □ □ □ □ □ HWG20 - 034 □ □ □ □ □ □ □ □

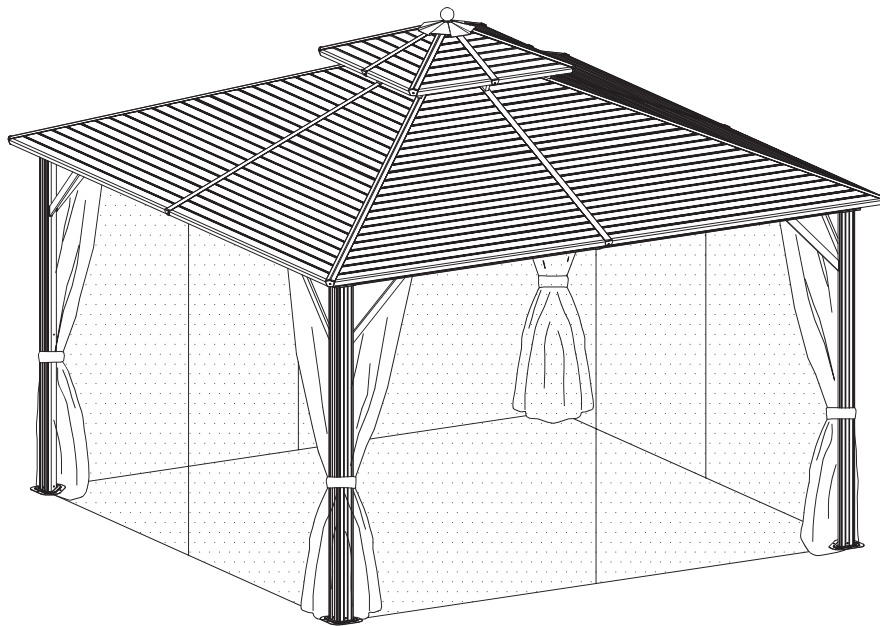

At least need 3 person work together

REQUIRED TOOLS

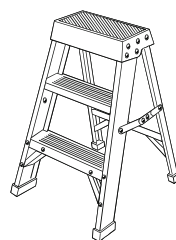
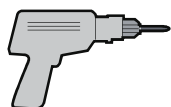

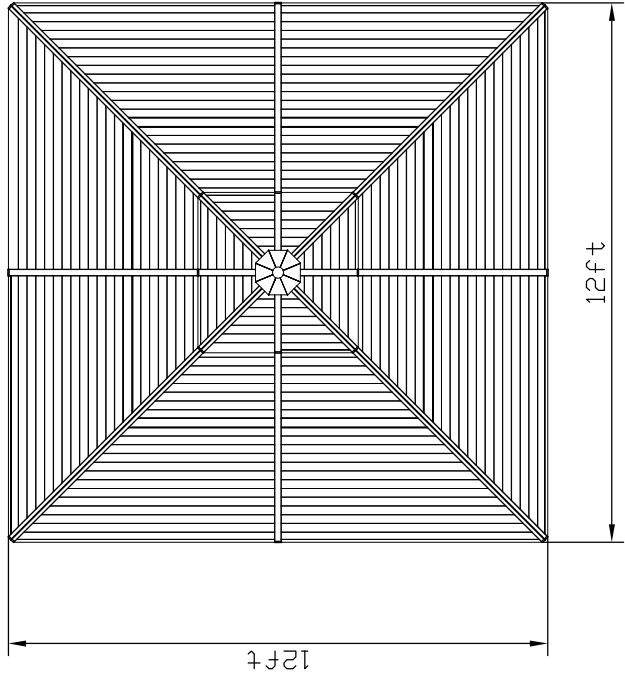
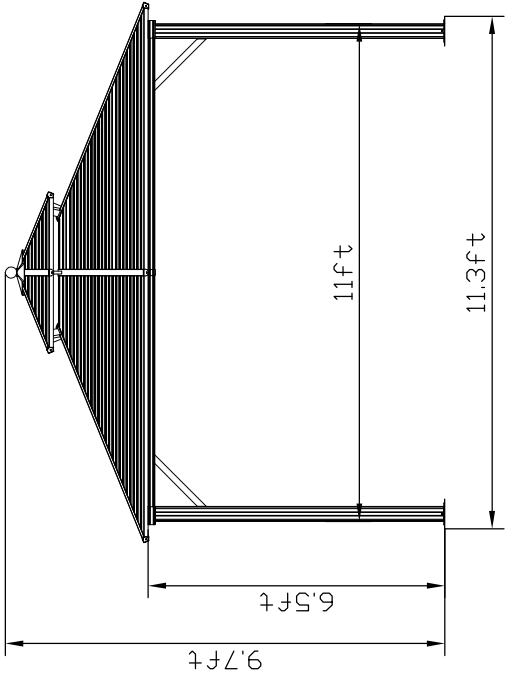
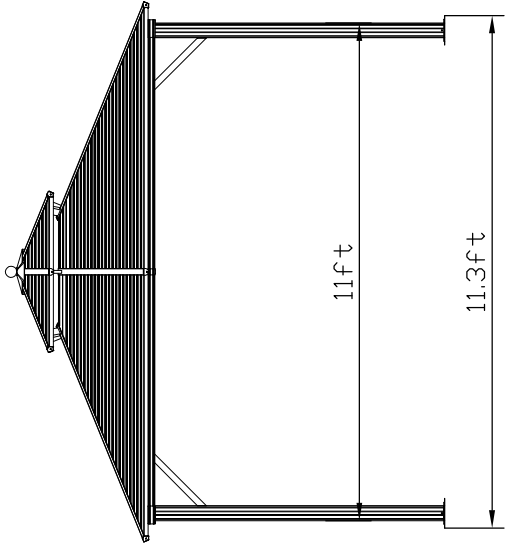

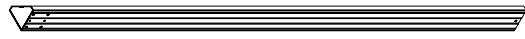

A 4x



B 4x



B1 4x



E 4x



E1 4x



F1 4x



F2 4x



F3 4x



F4 4x



G1 4x



G2 4x

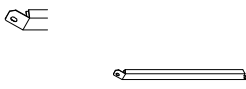

D1 4x

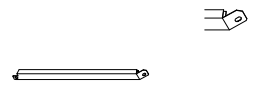

D2 4x



G3 4x



H 4x



H1 4x

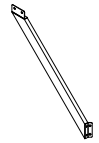

H2 4x

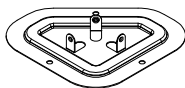

J 4x

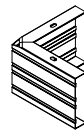

K 4x



K1 4x

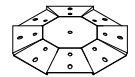

L 1x

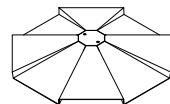

M 1x





N 12x

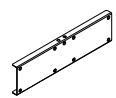

N1 8x

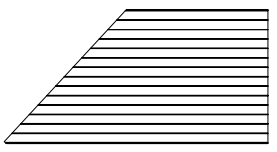
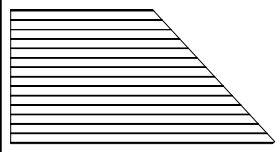
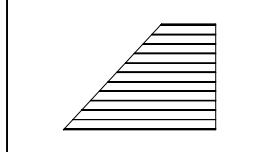
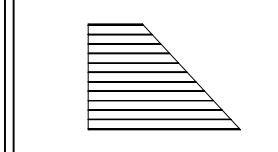
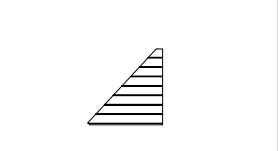
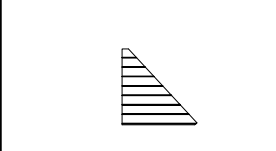
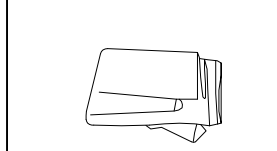
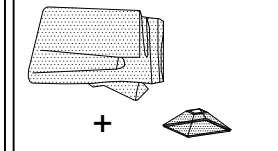
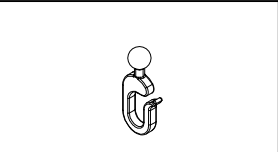
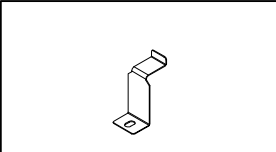
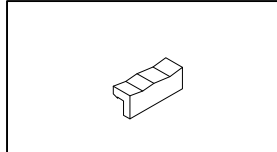
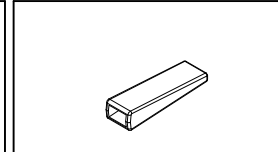
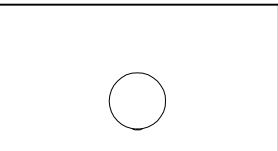
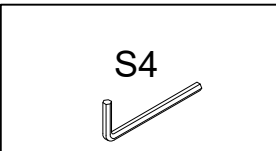
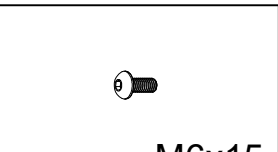

P 4x

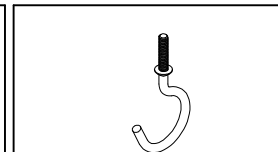
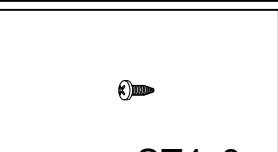
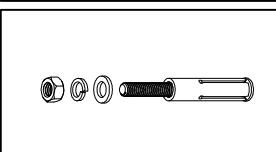
| | | | |
|---|---|--|---|
|  |  |  |  |
| Q1 4x | Q2 4x | R1 4x | R2 4x |
|  |  |  |  |
| S1 4x | S2 4x | T 4x | T1 4x + 1x |
|  |  |  |  |
| U 112x | V 4x | Y 32x | Y1 8x |
|  |  | | |
| Za 1x | S4 1x | | |
|  |  |  |  |
| M6x15 1 157x | M5x12 3 36x | ST4.8x12 4 24x | 5 1x |
|  |  | | |
| ST4x8 7 8x | 9 12x | | |

<1>

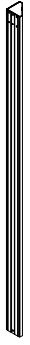

A 4x

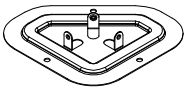

J 4x



1 12x M6x15

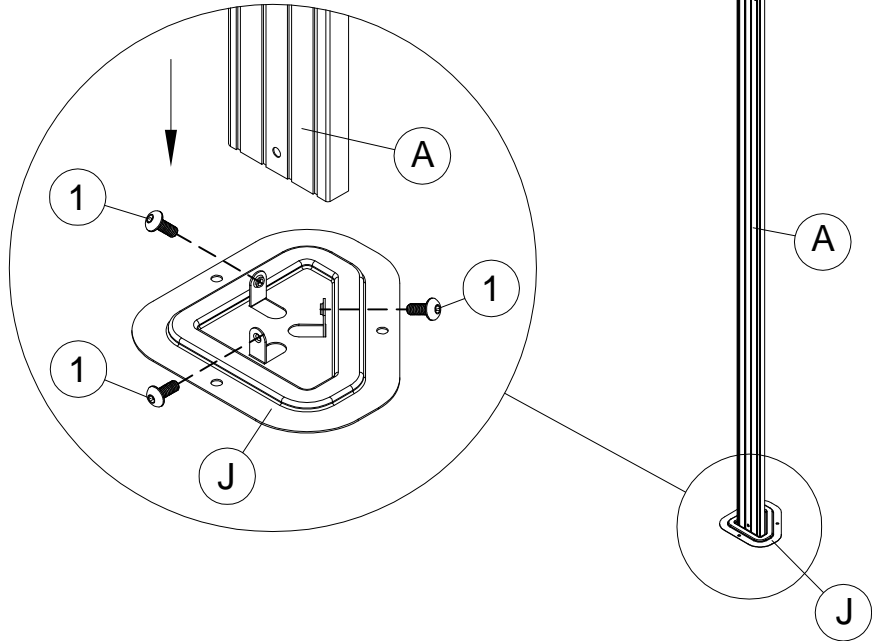

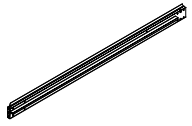

(B) 4x

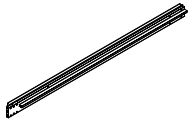

(B1) 4x

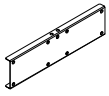

(P) 4x



(1) 40x M6x15

<2>

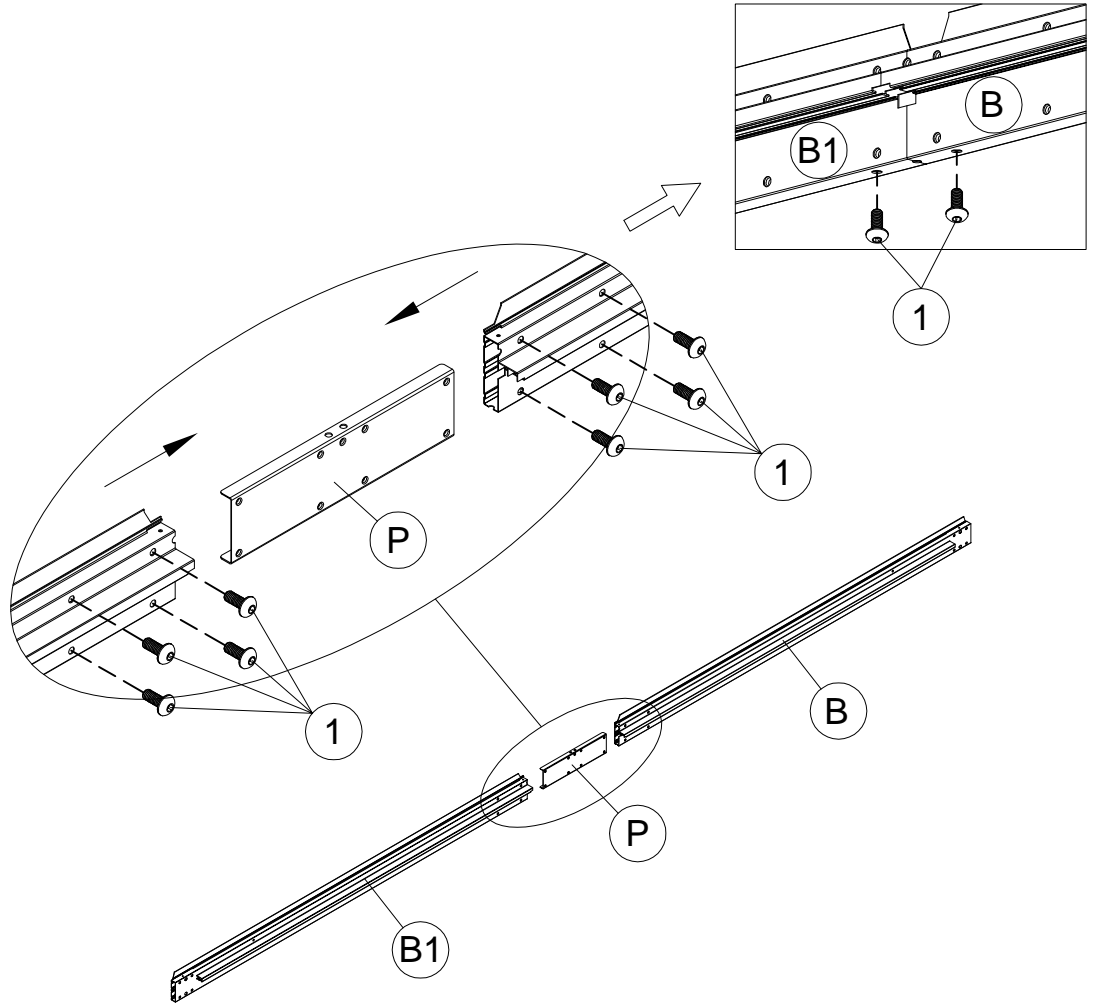



M6x15

1 32x

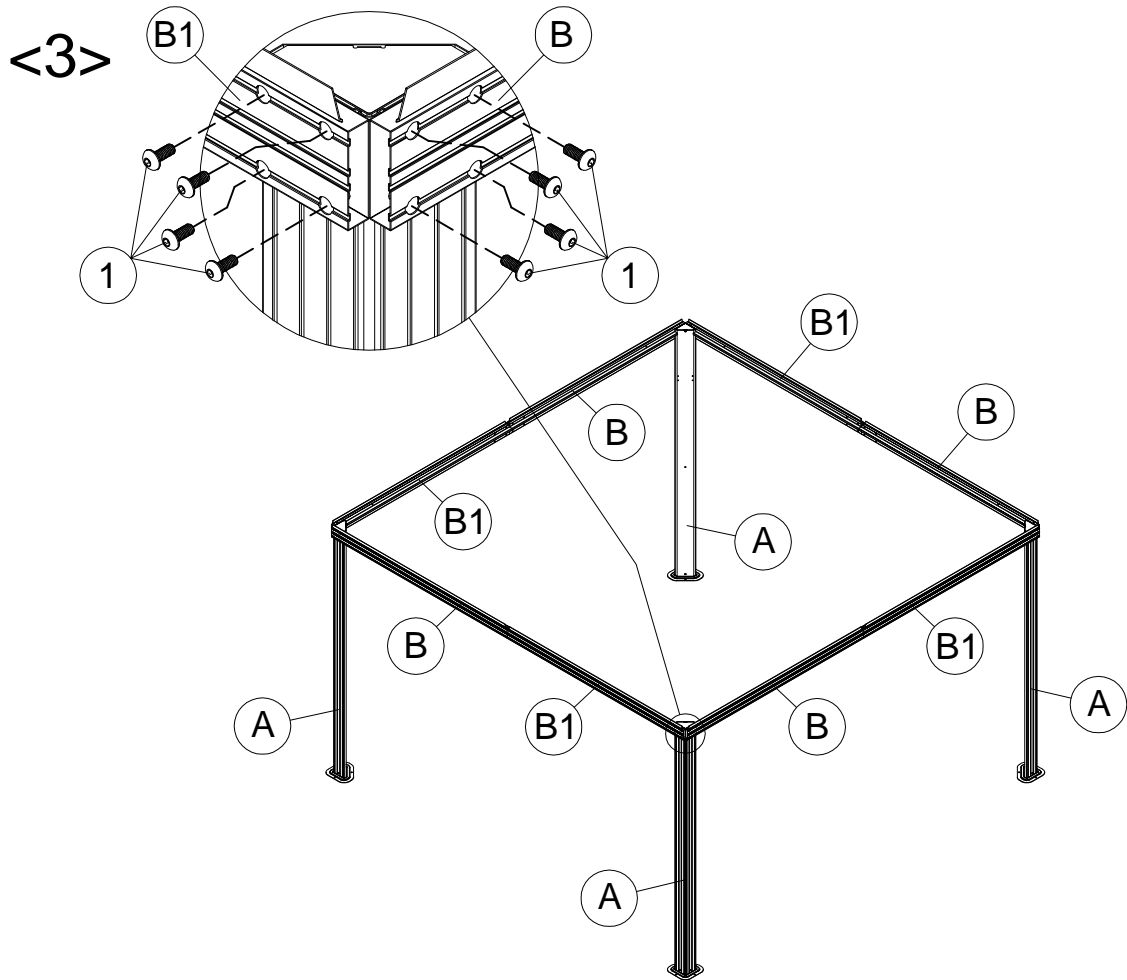

H1 4x

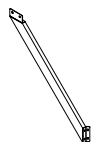

H2 4x



M5x12

3 32x

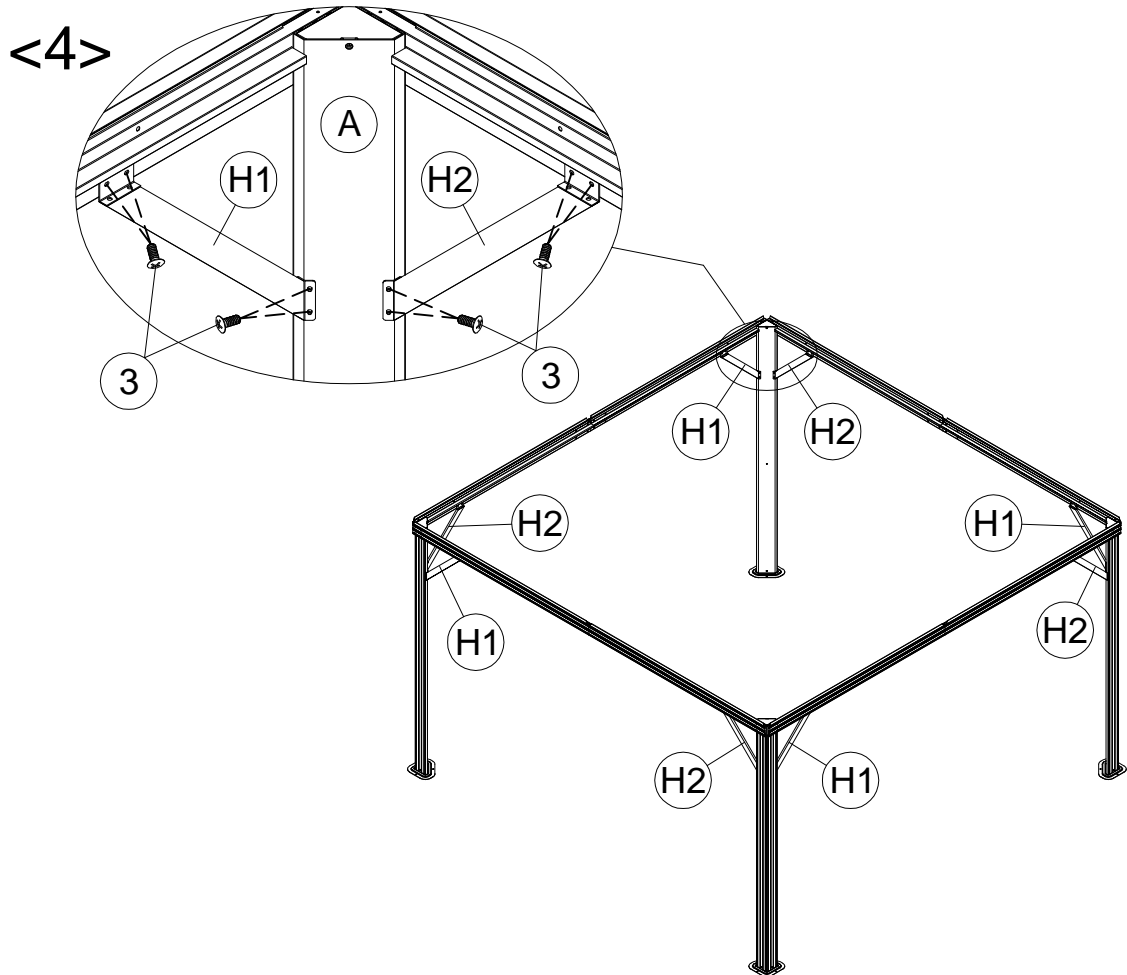

6



<5>

H 4x



1 8x M6x15

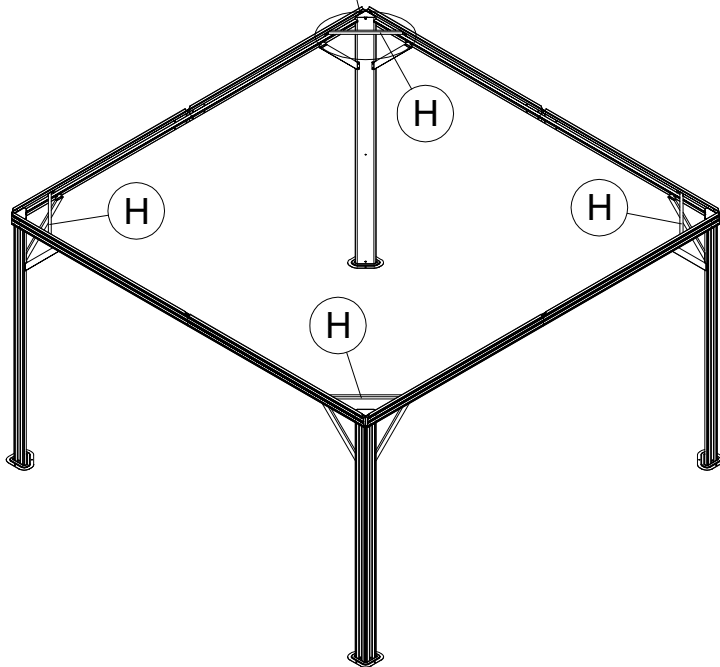
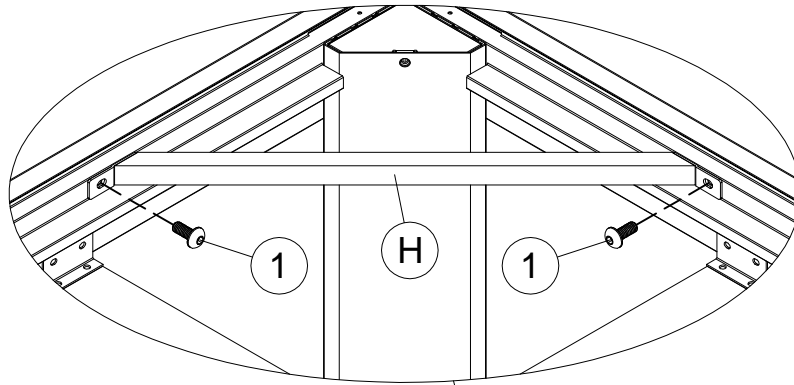

7

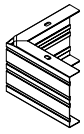

(K) 4x



(K1) 4x



(U) 112x



(V) 4x



(3) 4x M5x12



(4) 24x ST4.8x12

<6>

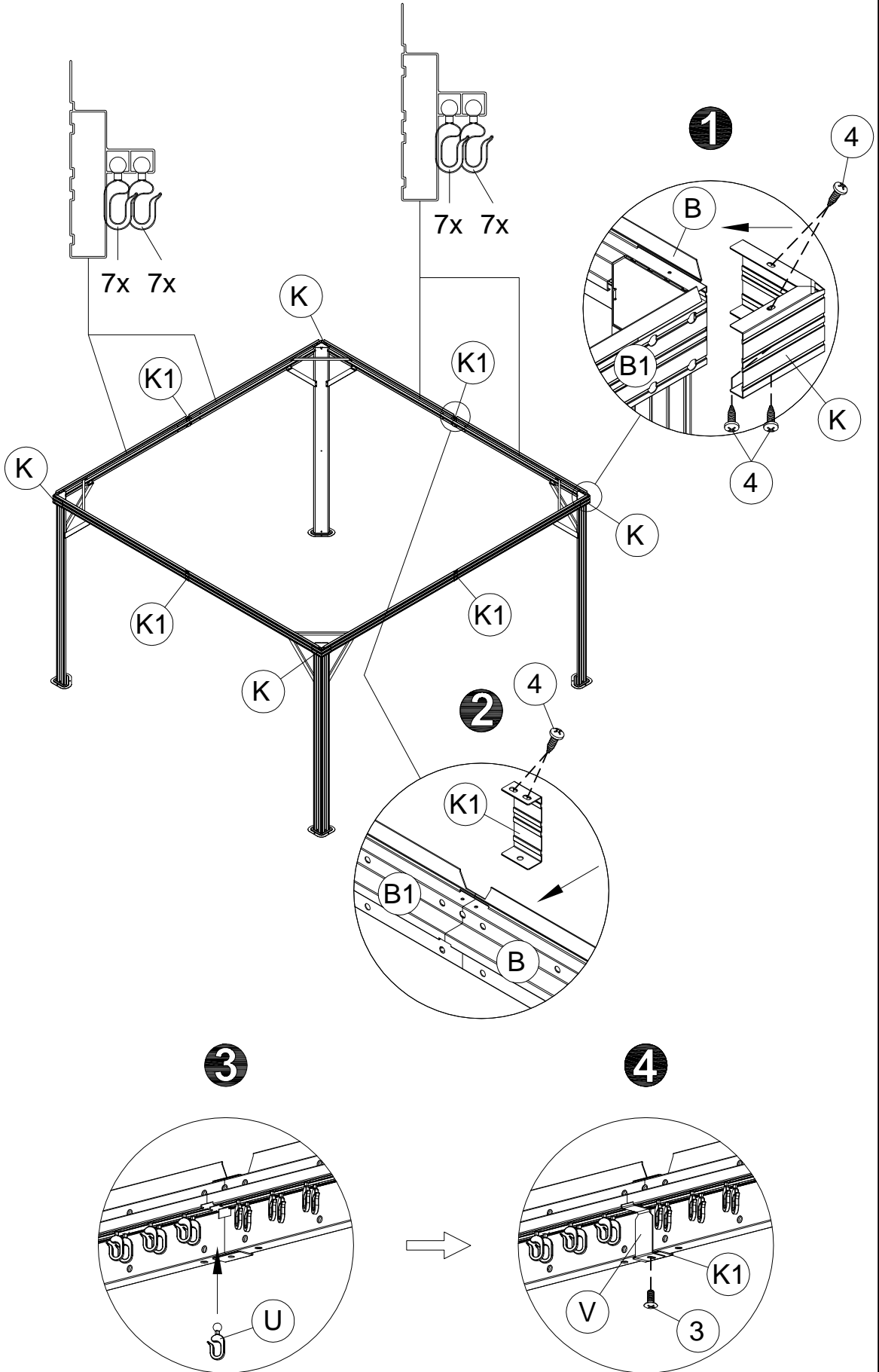

8

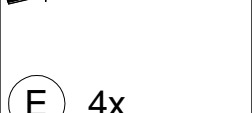
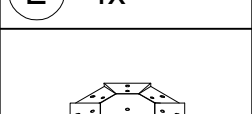
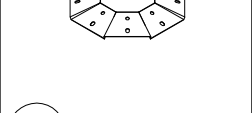
-  <7>
-  E 4x
-  L 1x
-  1 12x M6x15

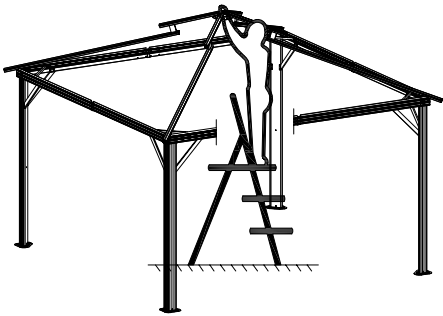
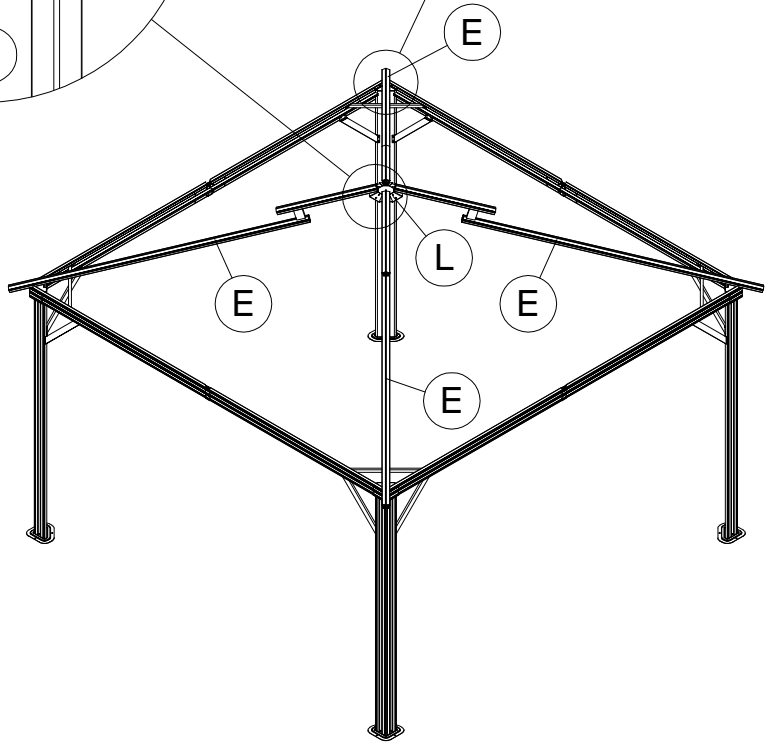
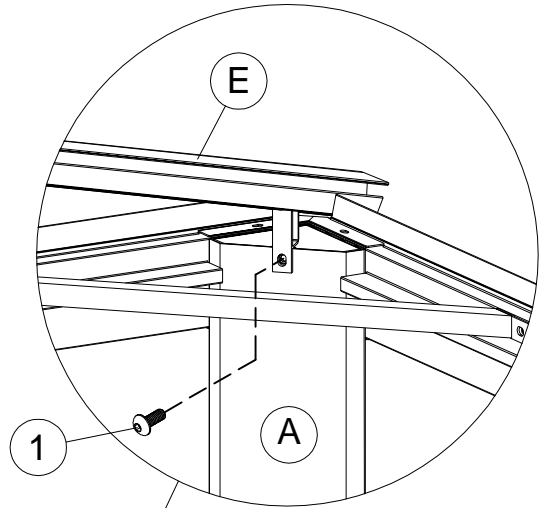
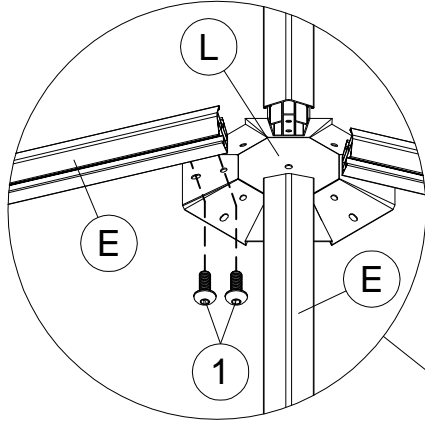

Note:

1. Let one person stand on the ladder to lift " L " and hold, and let others fasten the screws connecting both ends of " E " .
2. Please do not let go of holding " L " until all the " E " screws are installed.



<8>

E1 4x



1 M6x15
12x

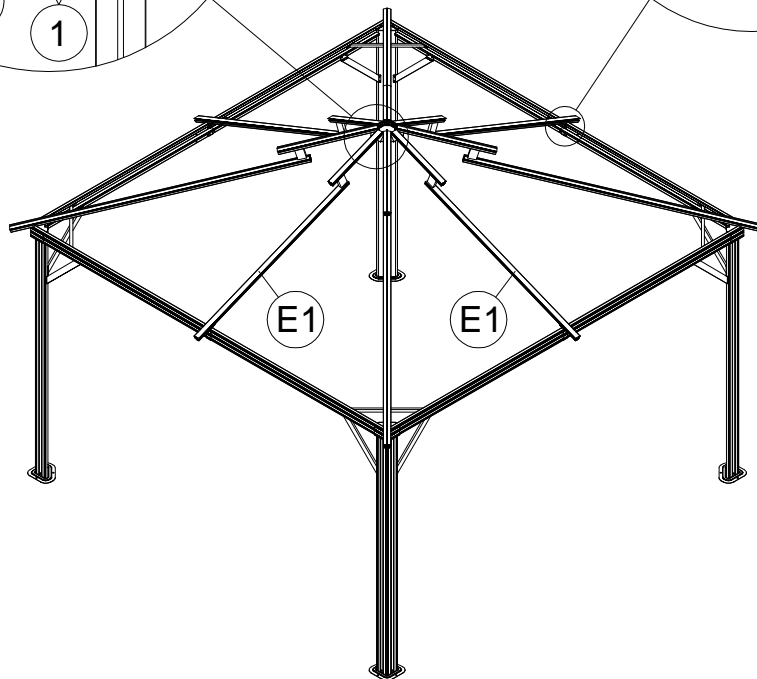
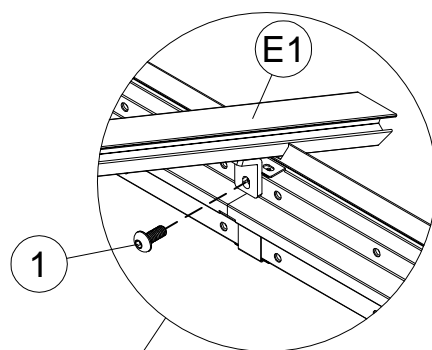
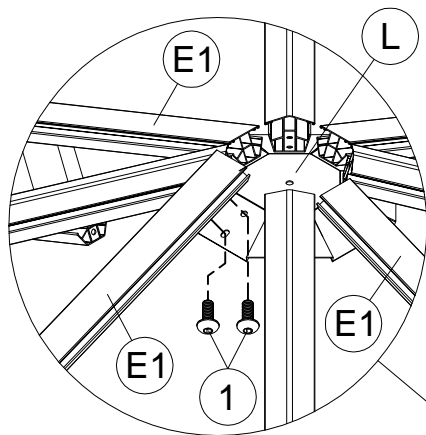

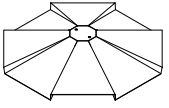

M 1x



Za 1x



1 1x M6x15



5 1x

<9>

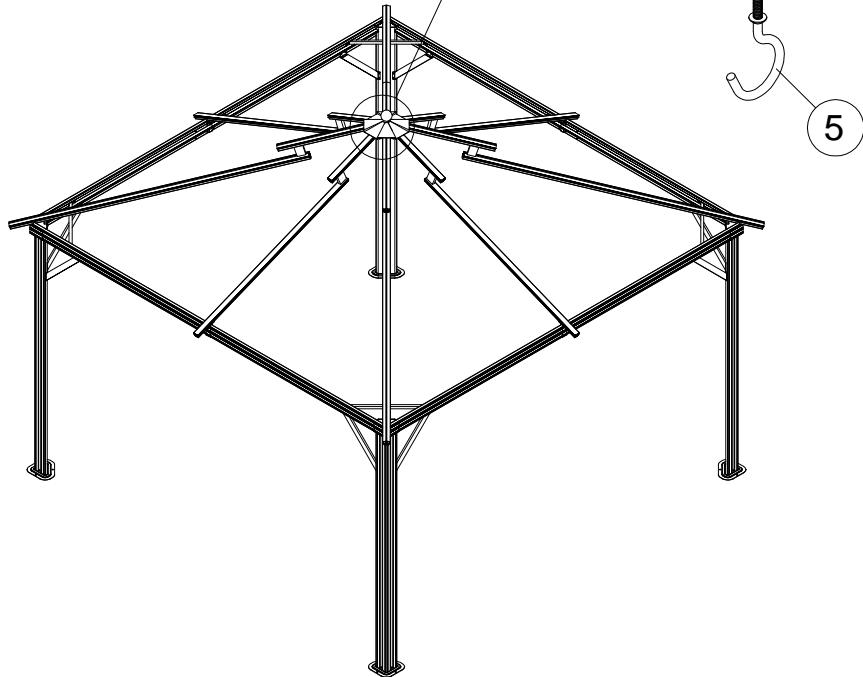
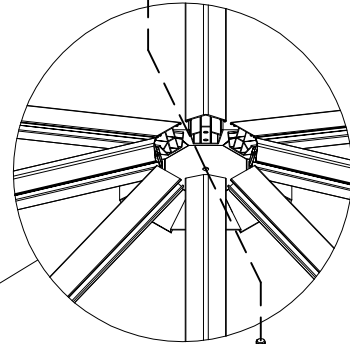
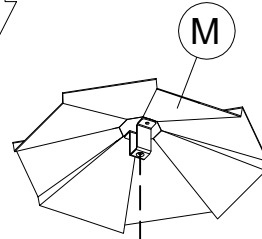
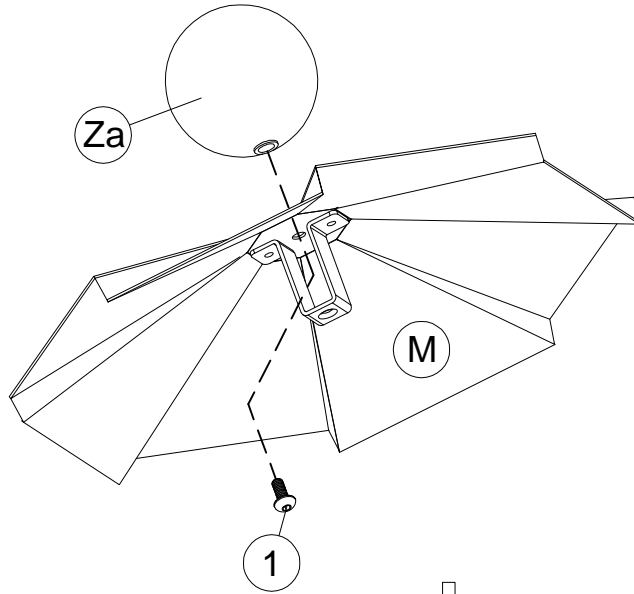



<10>

G3 4x



N 4x



1 8x M6x15

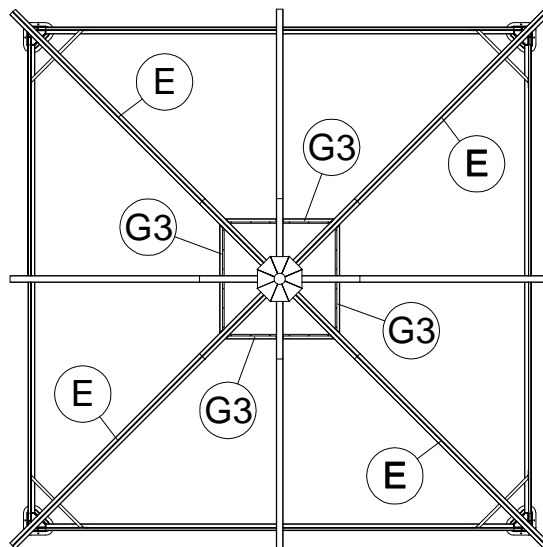
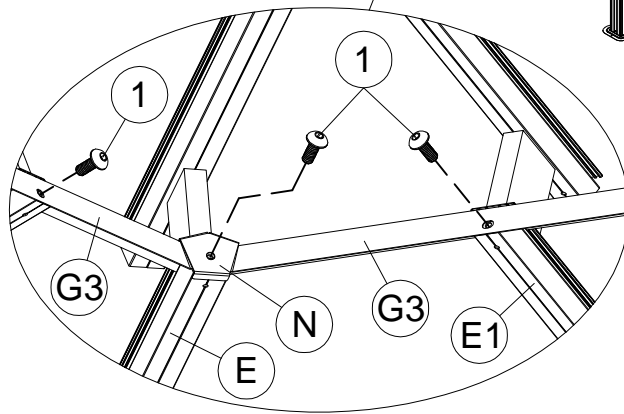
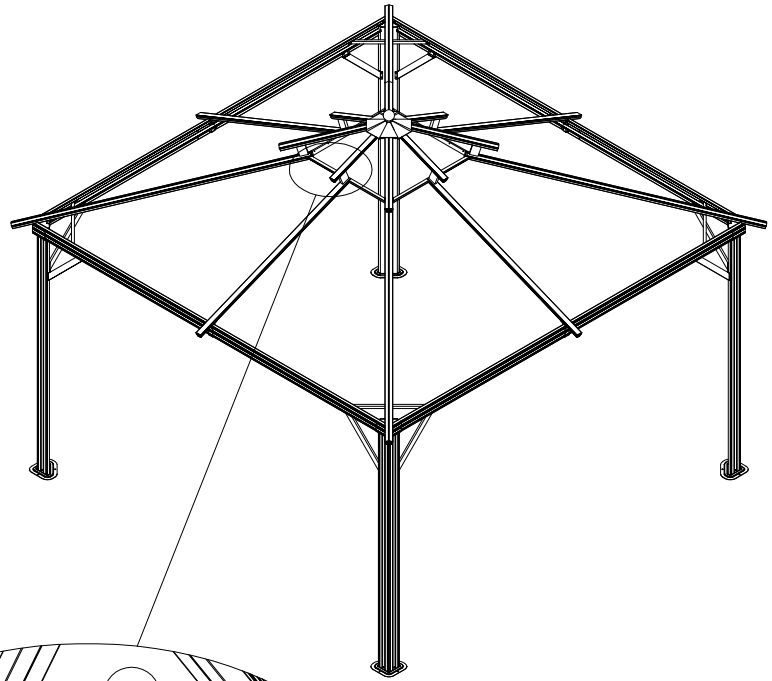

12



S1 4x



S2 4x

<11>

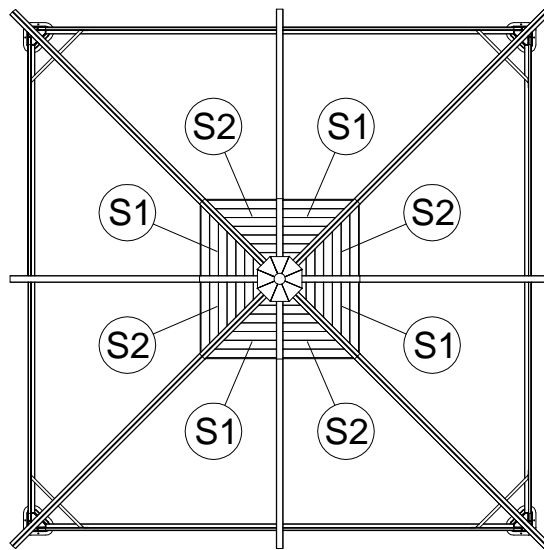
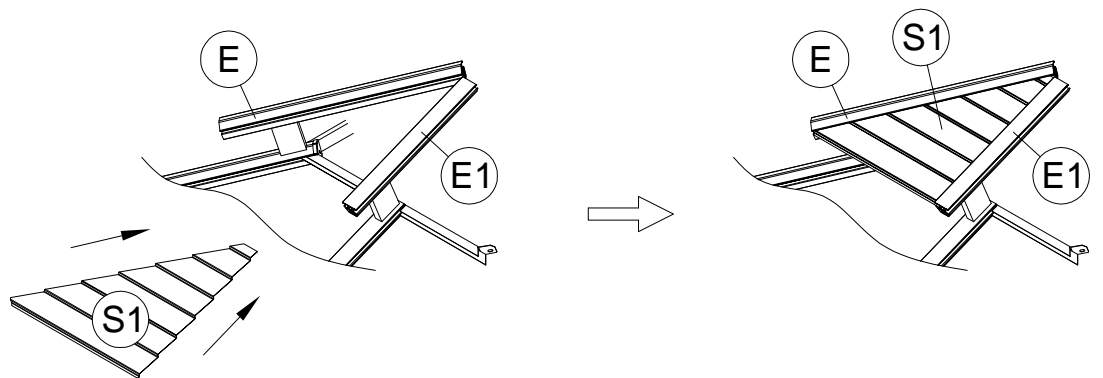
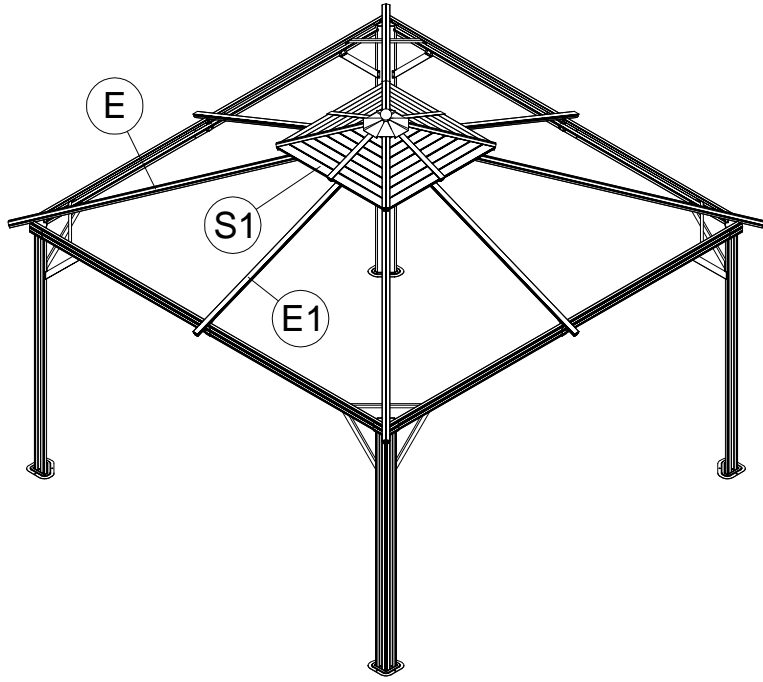

<12>



D1 4x



D2 4x



N 4x



N1 4x



1 8x M6x15

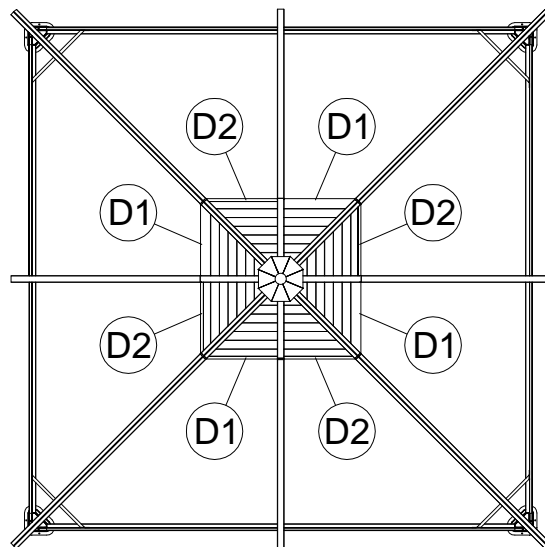
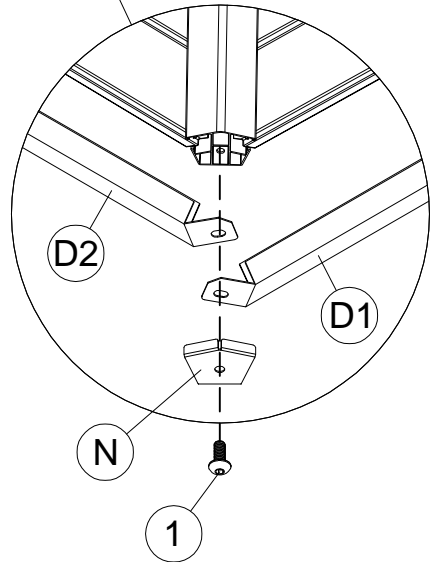
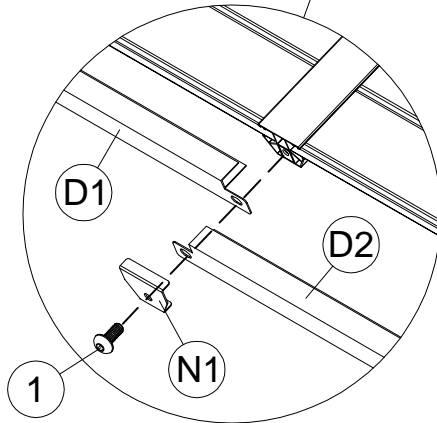
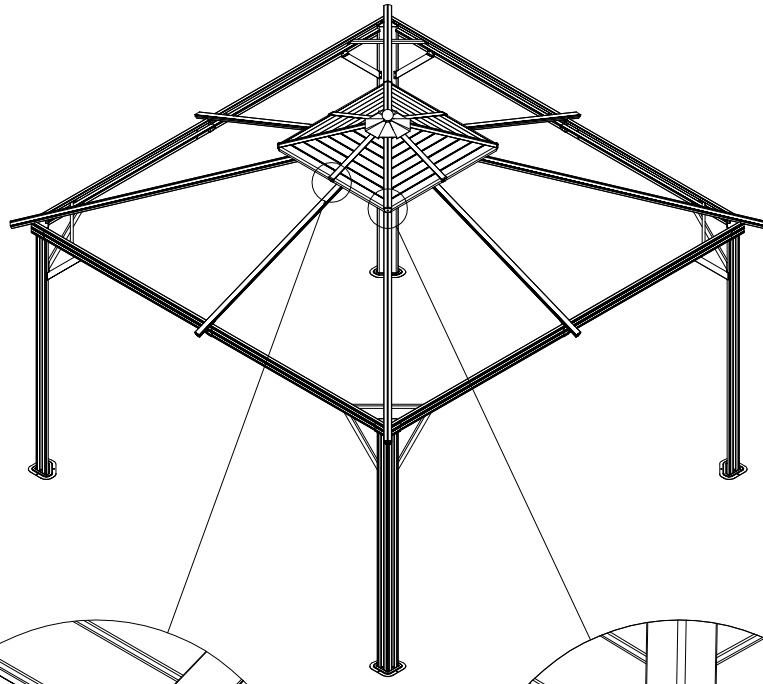

<13>

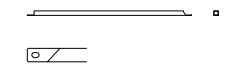

F3 4x

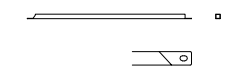

F4 4x



1 8x M6x15

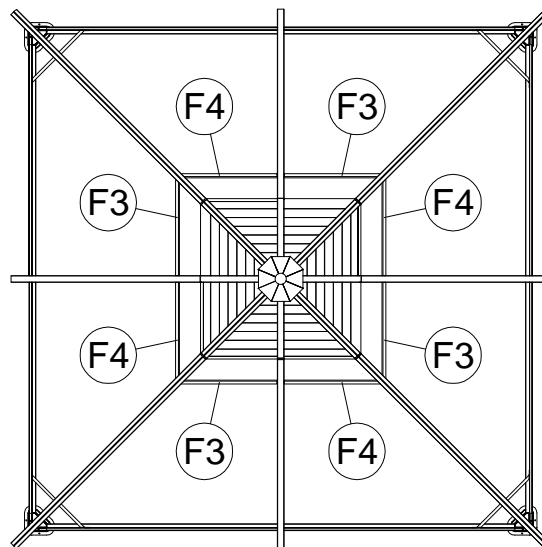
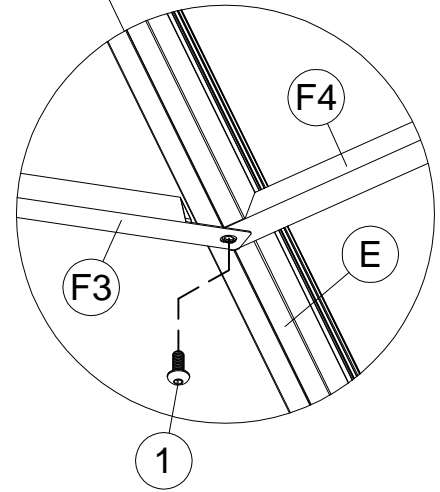
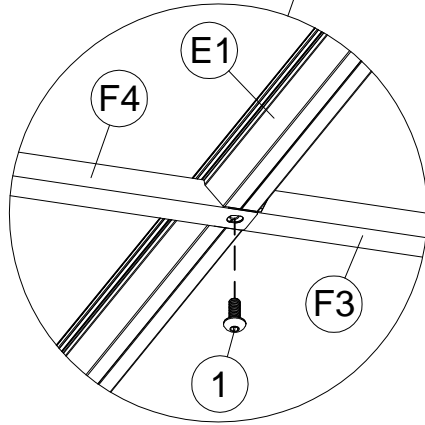
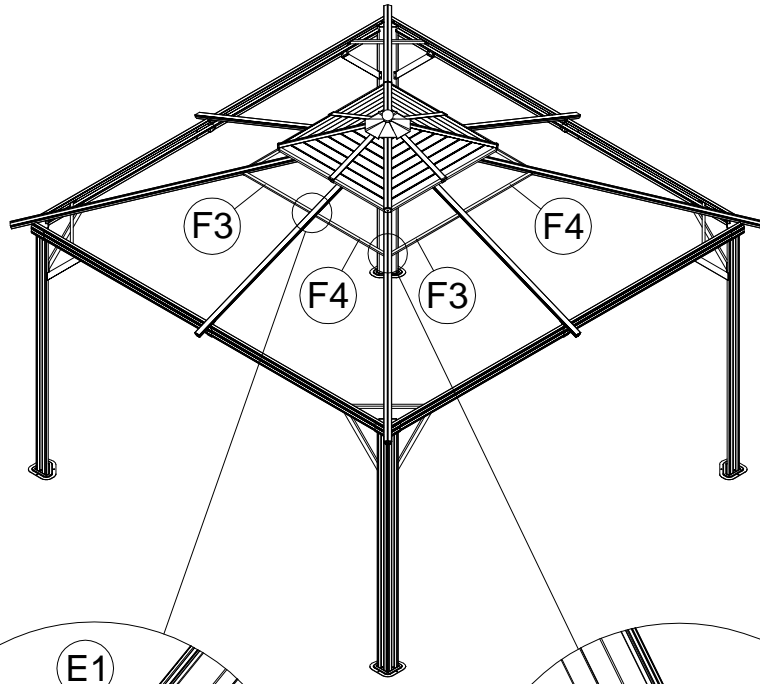

<14>



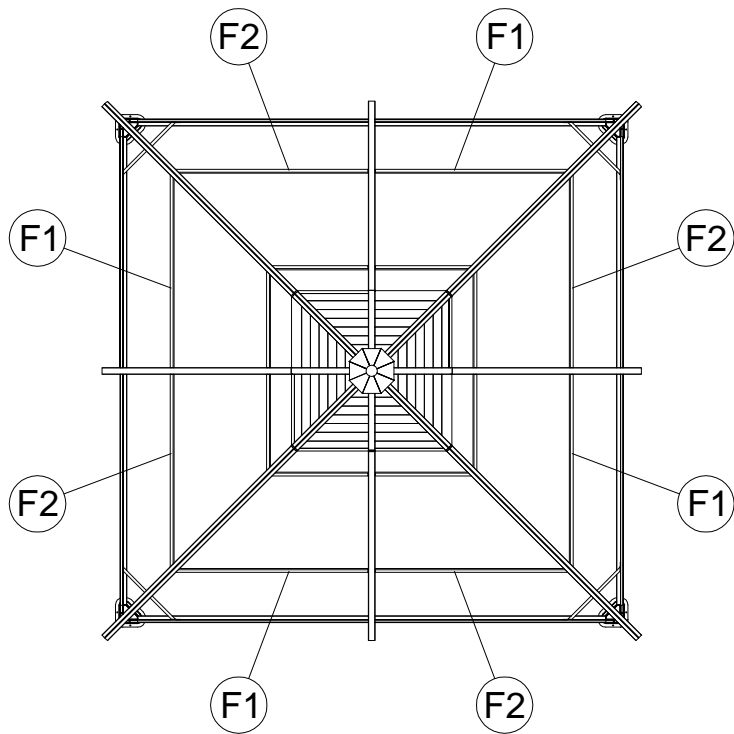
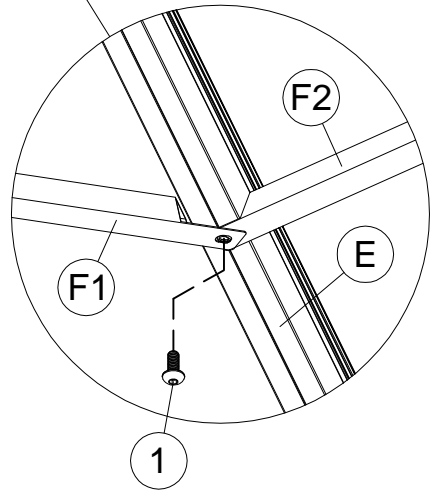
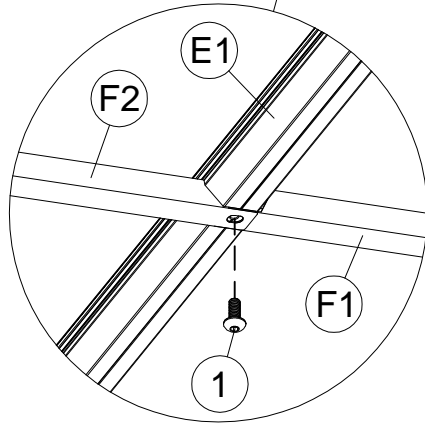
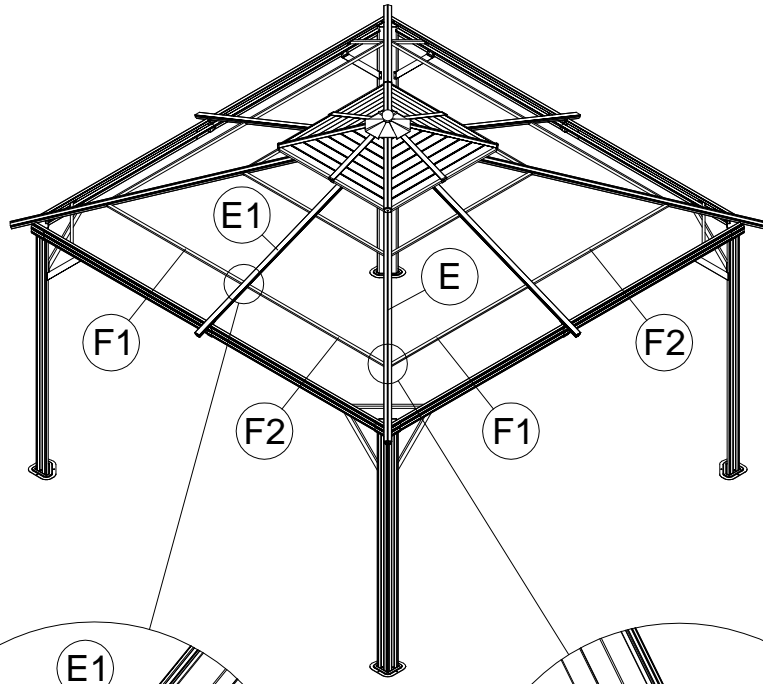

F1 4x

F2 4x

1 8x M6x15

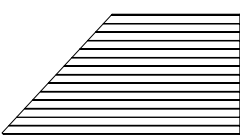
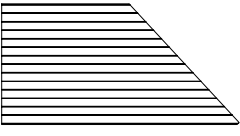
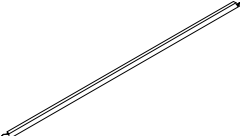
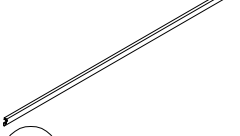

<15>

-  Q1 4x
-  Q2 4x
-  G1 4x
-  G2 4x
-  N 4x
-  N1 4x
-  1 8x M6x15

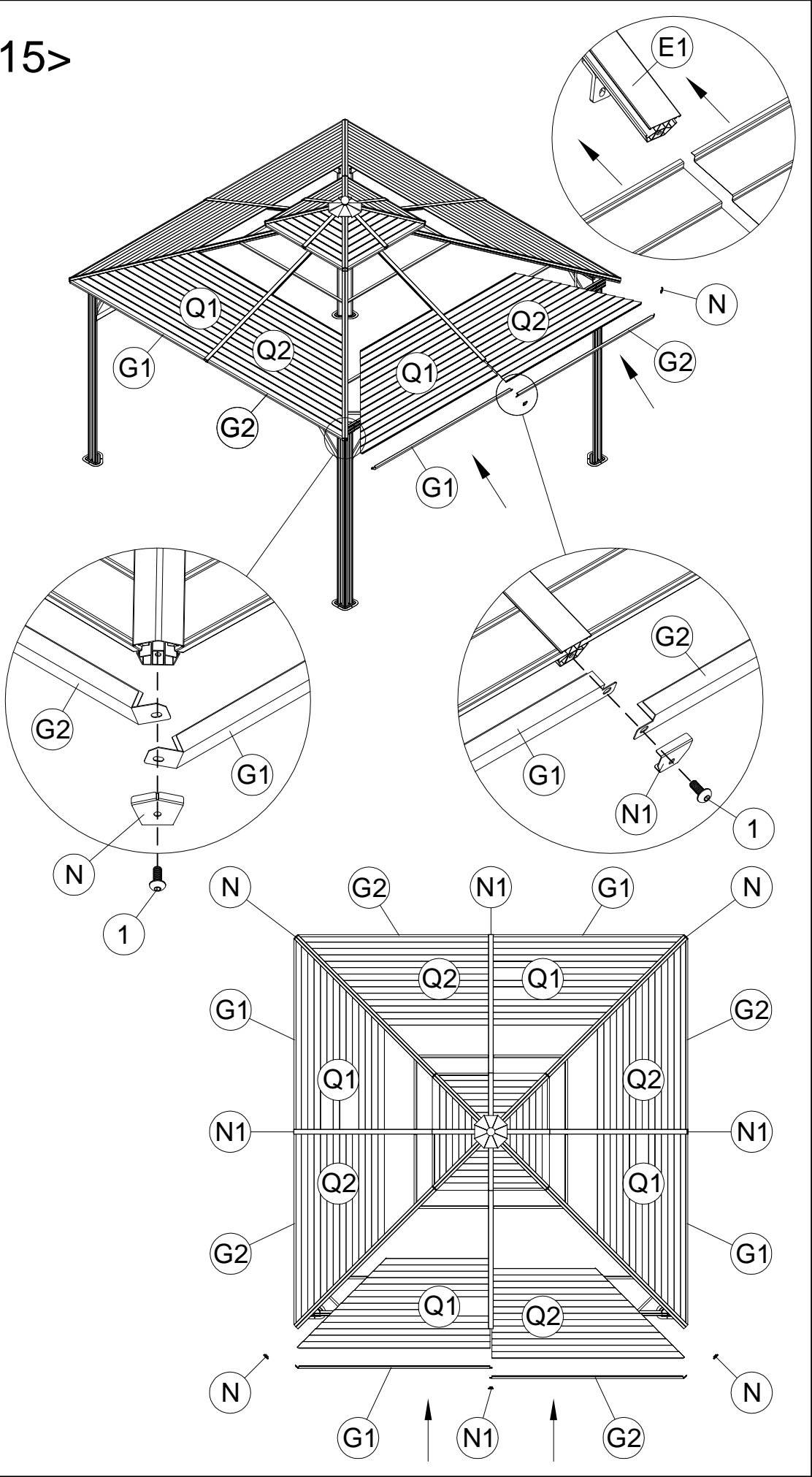

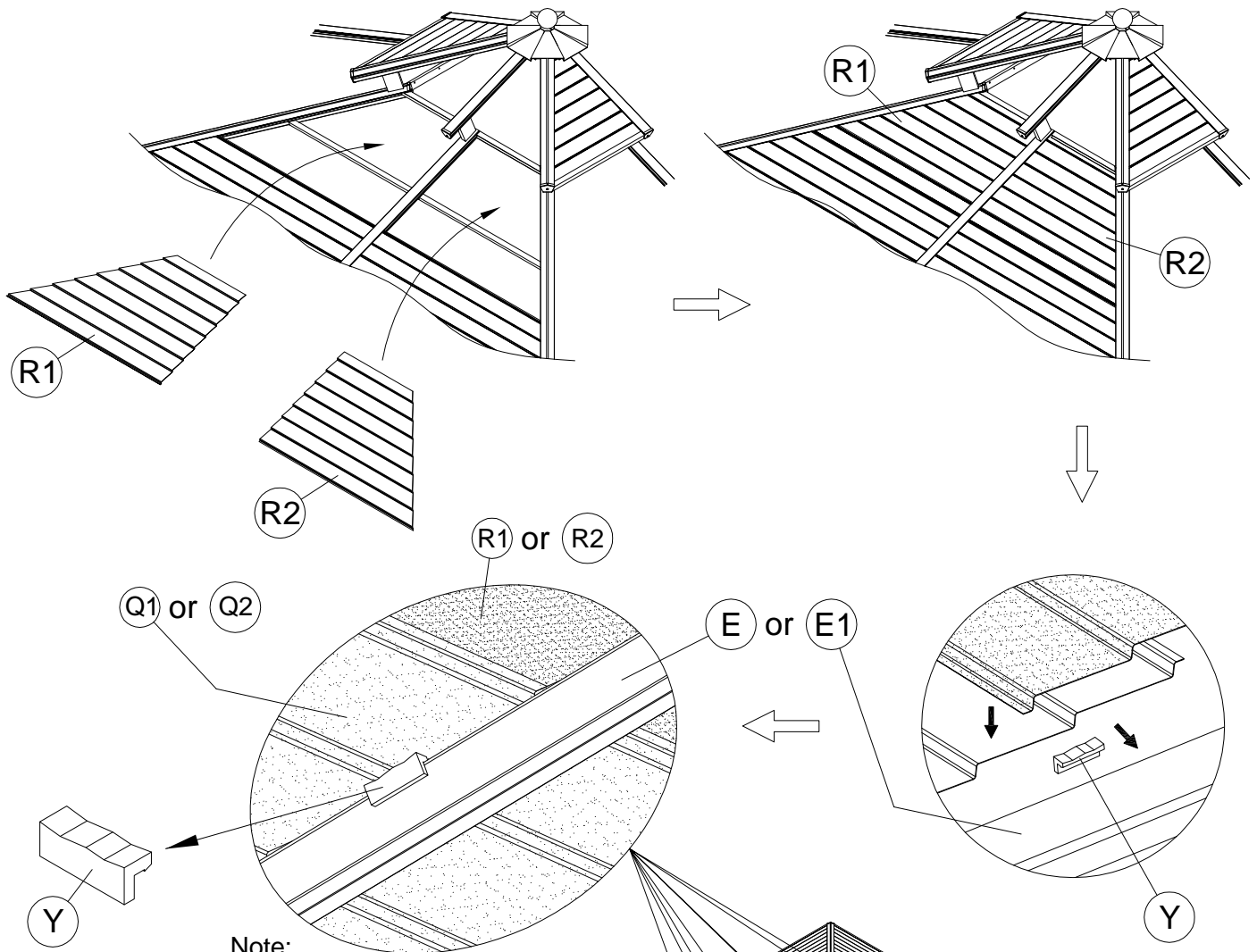

<16>

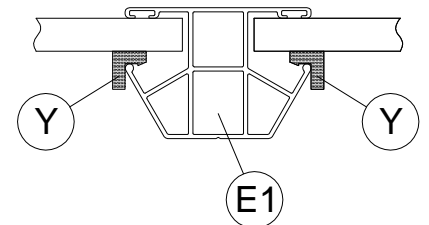
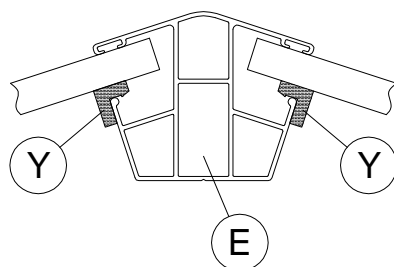
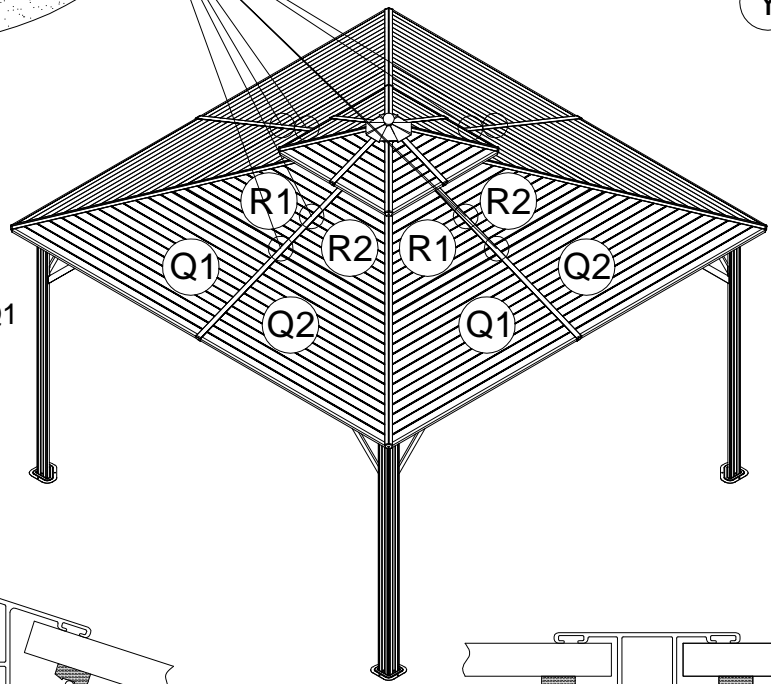

Note:

1. Y is stuck in the position of the edges where the small piece (R1 or R2) and the large piece (Q1 or Q2) overlap.
2. R1 or R2 must pile up on the top of Q1 or Q2.

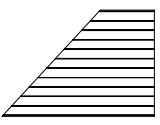
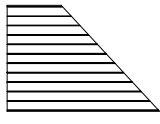

| | |
|---|-------|
|  | R1 4x |
|  | R2 4x |
|  | Y 32x |
| 18 | |

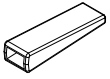

<17>

Y1 8x



7 8x ST4x8

Note: pls use power tools to drill the screws.

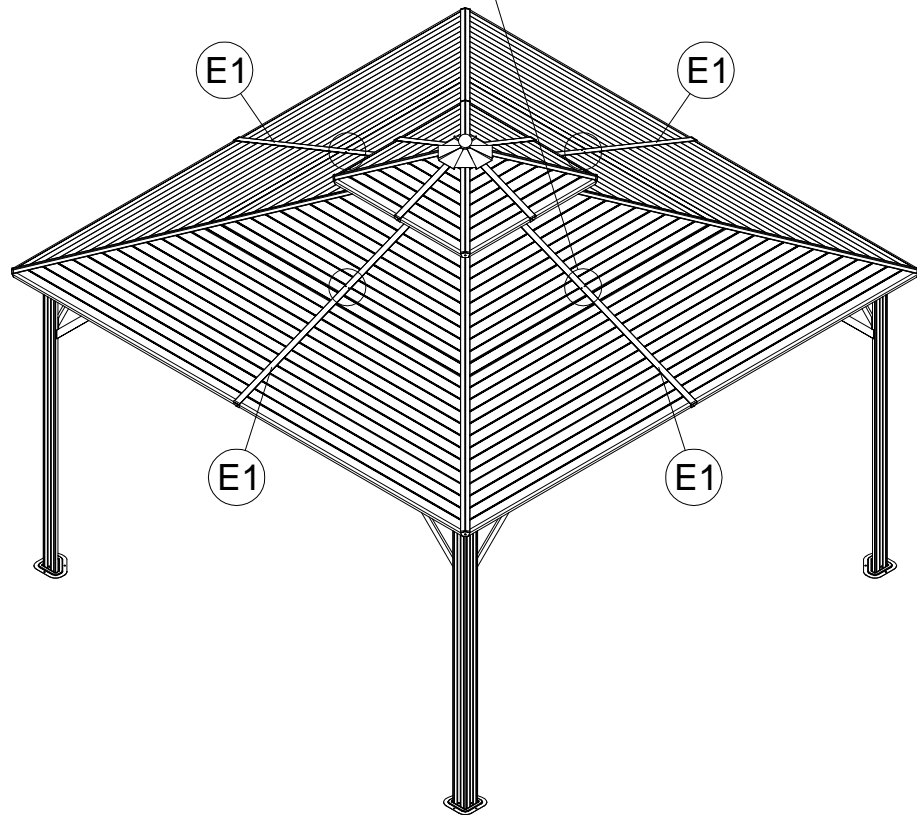
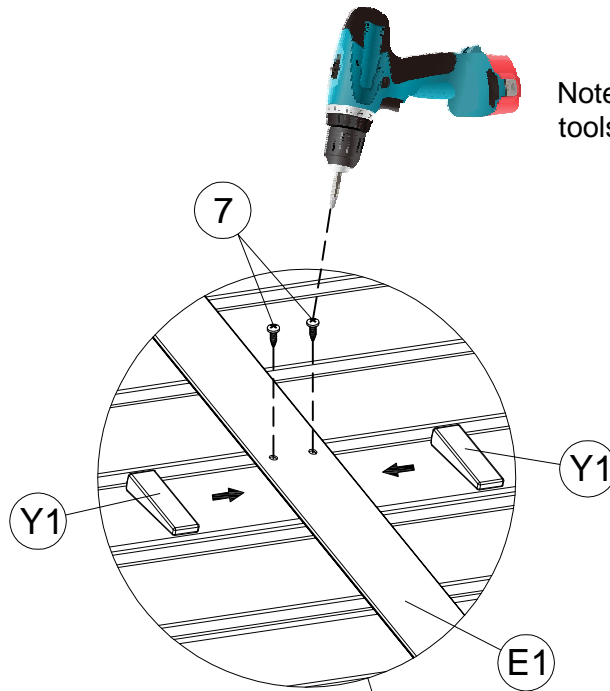

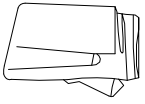

<18>

T 4x

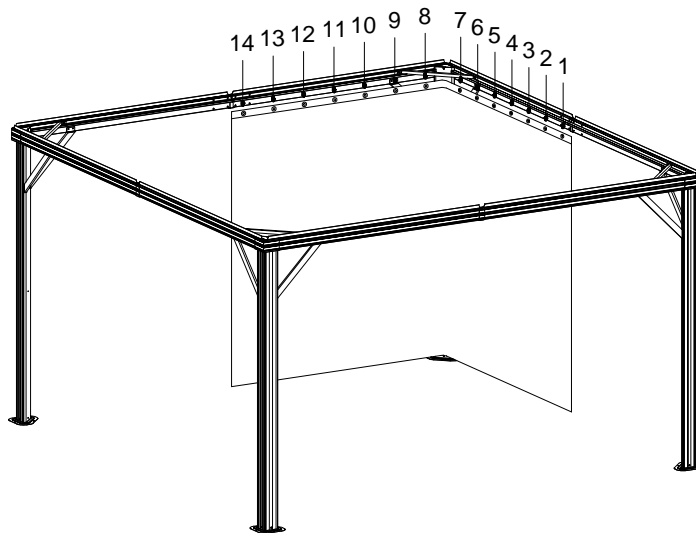
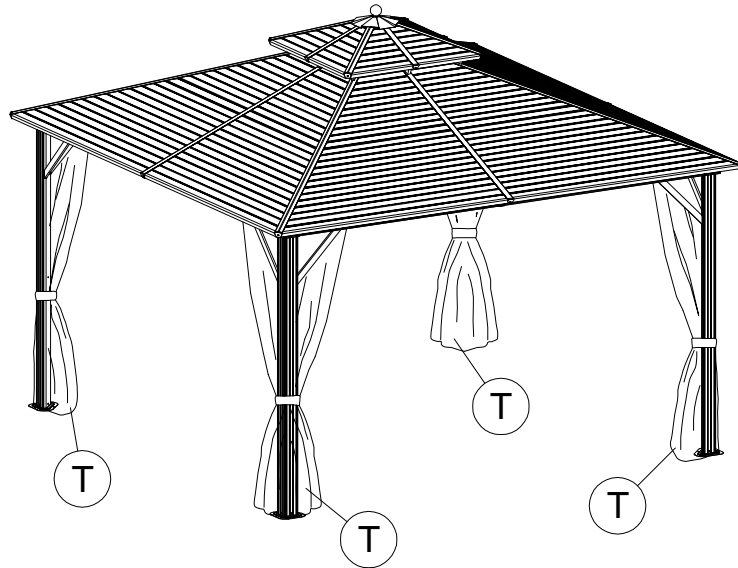
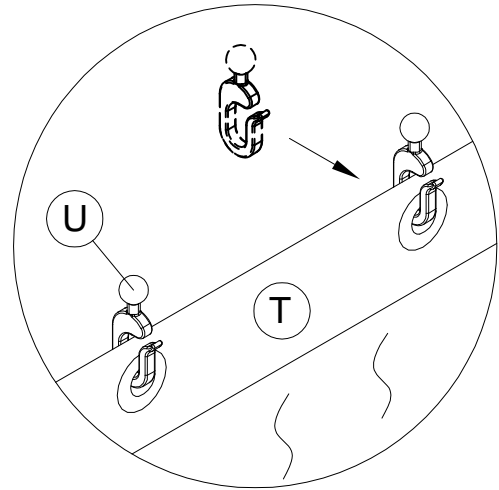
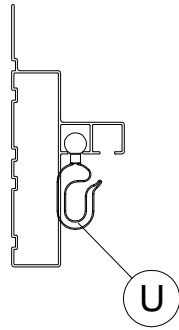

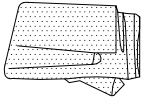

+



T1 4x + 1x



9 12x

<19>

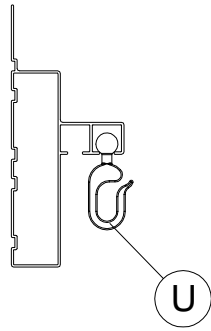

3

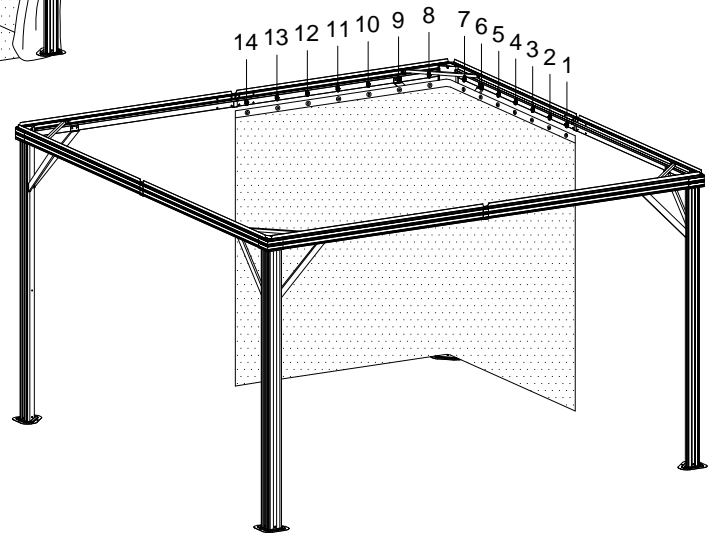
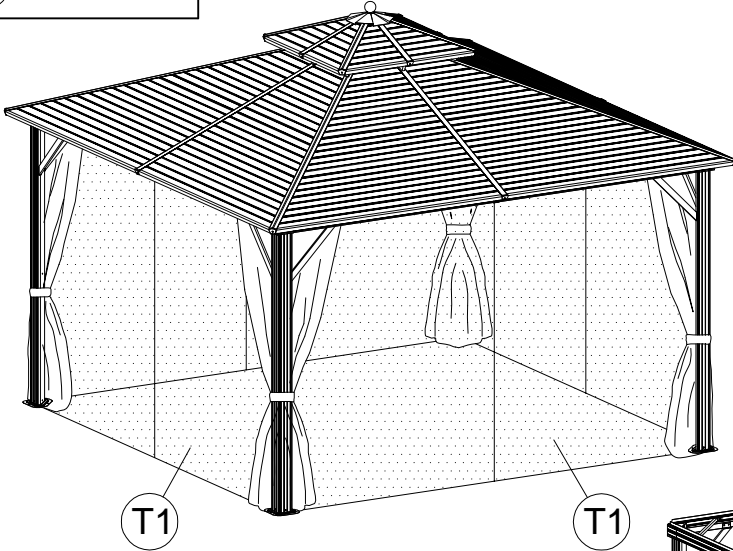
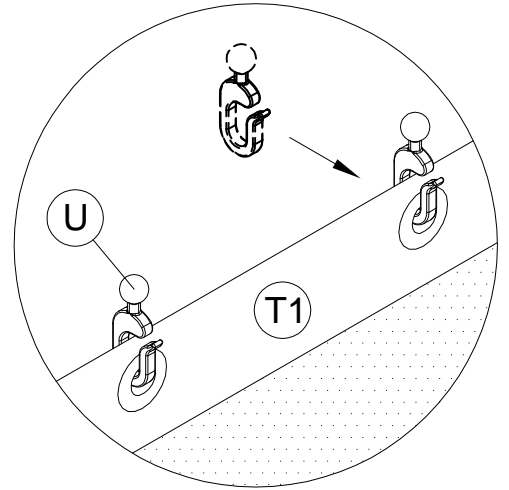

1



2

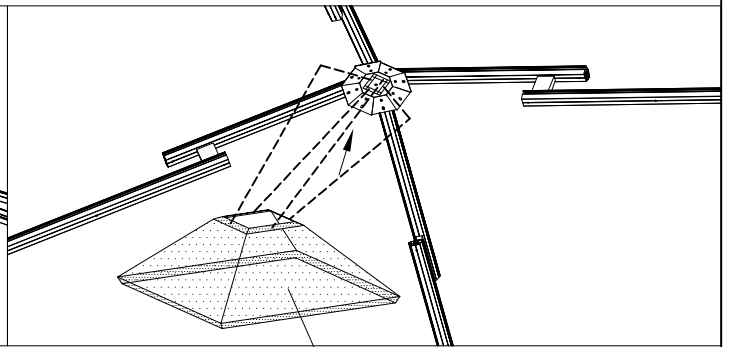
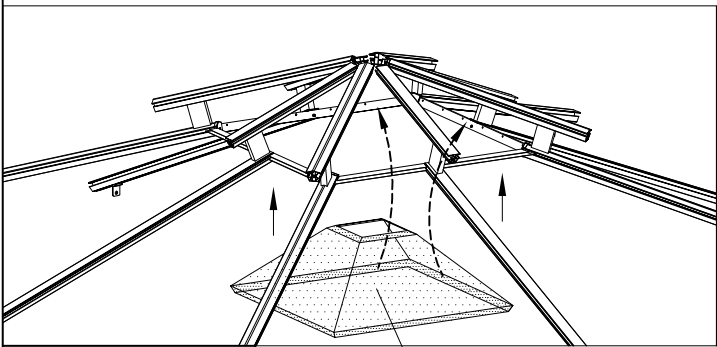

21

T1

T1



<20>

9 12x

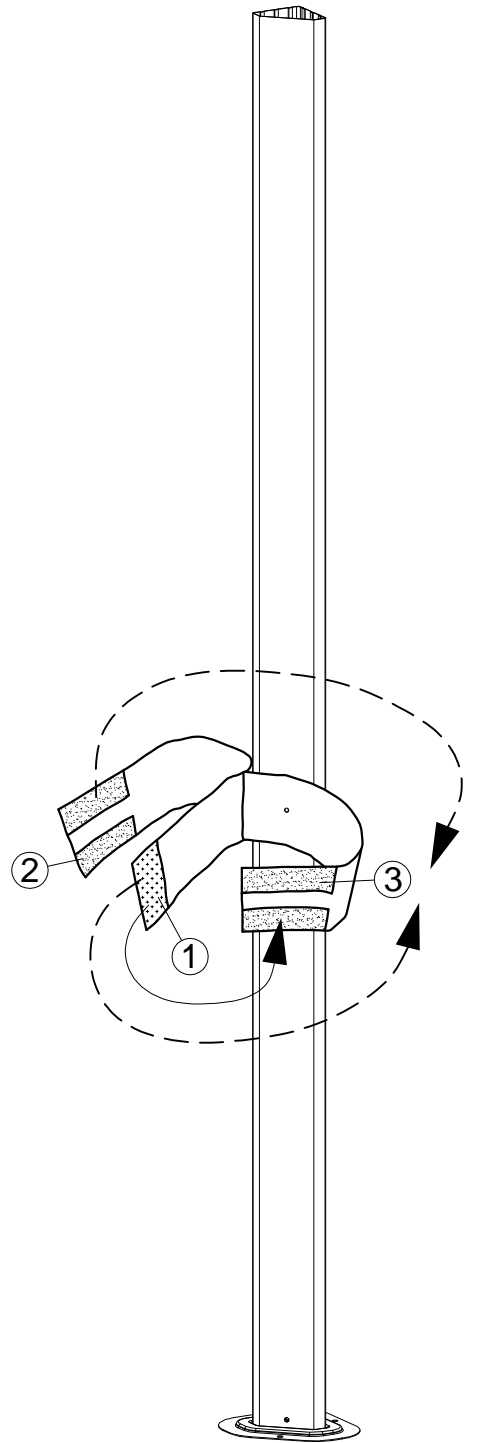
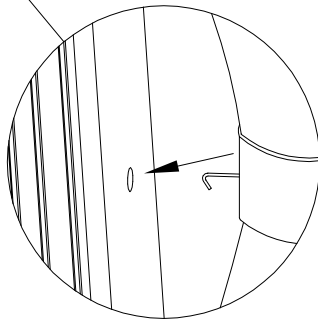
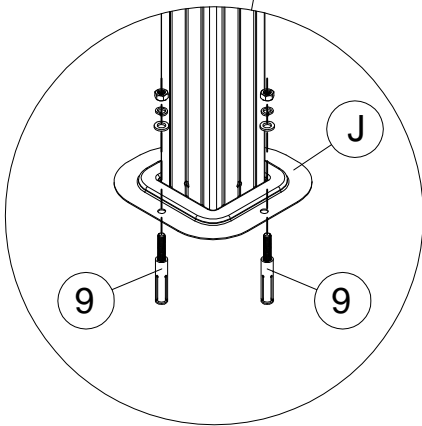
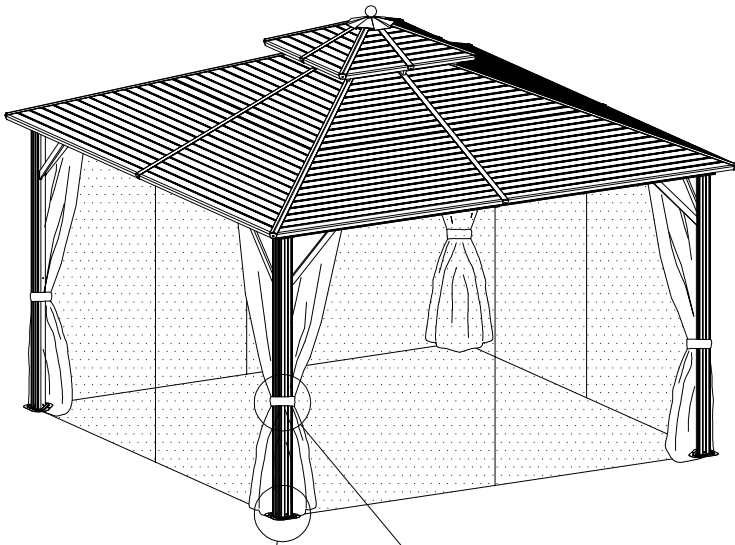

Note:

1. 1 stick 2 tie S and T together
2. 1 stick 3 towards back tie T
3. 1 stick 3 towards front tie S

| Carton-1/4 | | Carton-2/4 | | Carton-4/4 | |
|------------|-----|-----------------|-------|------------|-----|
| Part | Qty | Part | Qty | Part | Qty |
| D1 | 4 | B | 4 | Q1 | 4 |
| D2 | 4 | B1 | 4 | Q2 | 4 |
| E | 4 | J | 4 | R1 | 4 |
| E1 | 4 | K | 4 | R2 | 4 |
| F1 | 4 | K1 | 4 | S1 | 4 |
| F2 | 4 | N.N1.U.V.Y.Y1.9 | 1 | S2 | 4 |
| F3 | 4 | 1.3.4.5 | 1 | | |
| F4 | 4 | | | | |
| G1 | 4 | | | | |
| G2 | 4 | | | | |
| G3 | 4 | | | | |
| H | 4 | | | | |
| H1 | 4 | | | | |
| H2 | 4 | | | | |
| | | Carton-3/4 | | | |
| L | 1 | Part | Qty | | |
| M | 1 | A | 4 | | |
| P | 4 | T | 4 | | |
| Za | 1 | T1 | 4 + 1 | | |
| | | | | | |