

# 10 x 13 FT

□ □ □ □ □ □ □ □ HWG - 013 □ □ □ □ □ □ □ □

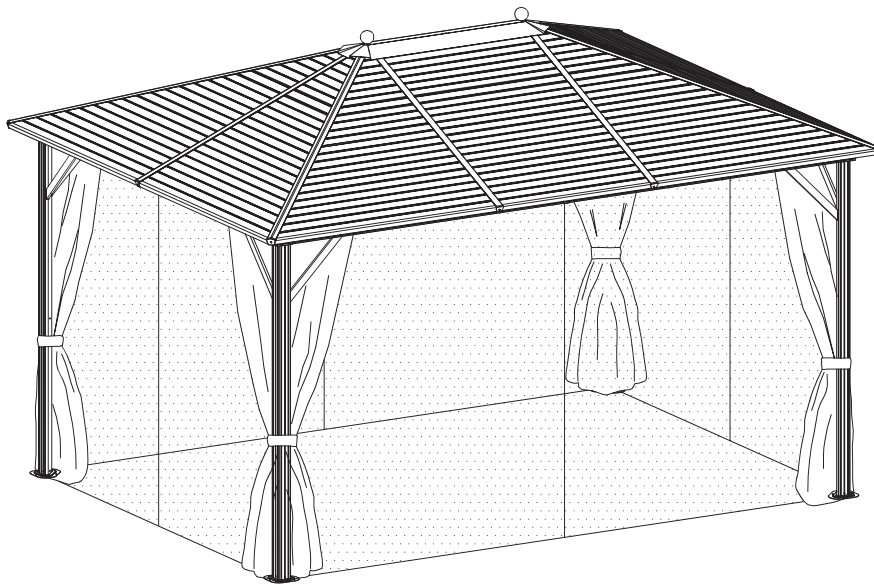

At least need 3person work together

## REQUIRED TOOLS

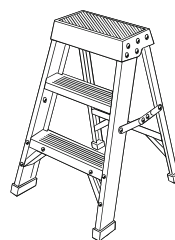
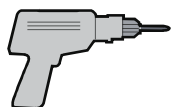

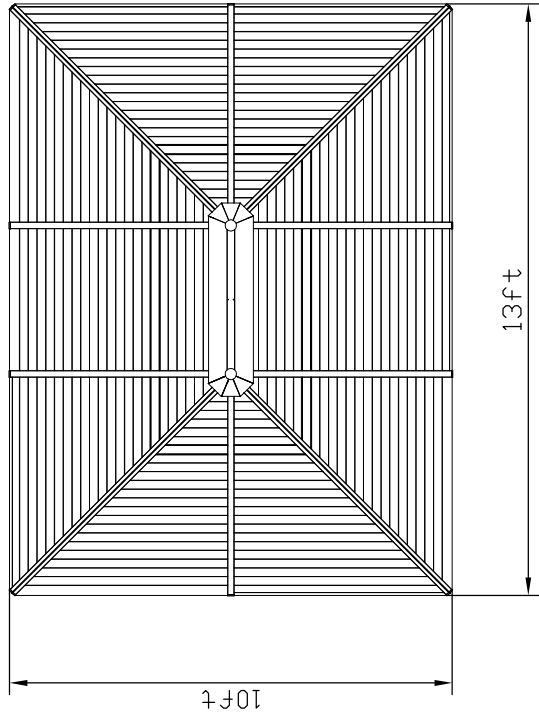
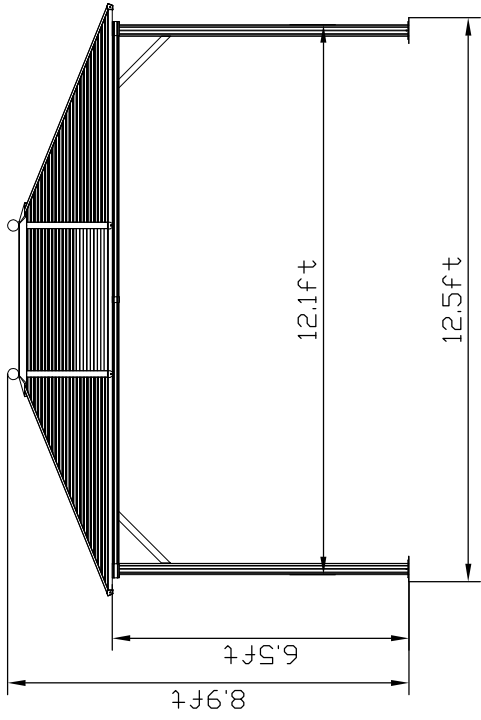
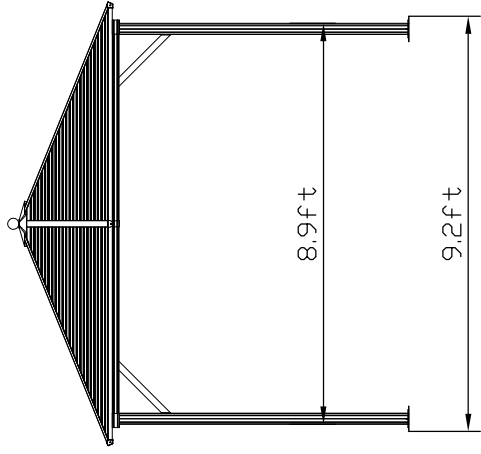



A 4x



B 2x



B1 2x



C 2x



C1 2x

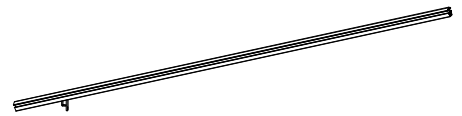

D 4x



E 6x



F 2x

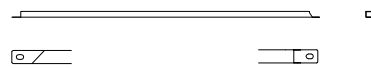

F1 4x

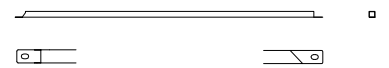

F2 4x



G 2x



G1 4x



G2 4x



H1 4x

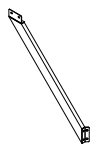

H2 4x

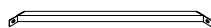

H 4x

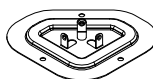











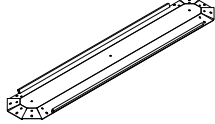
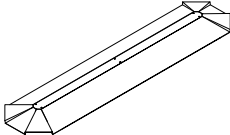

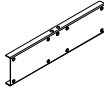
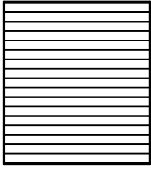
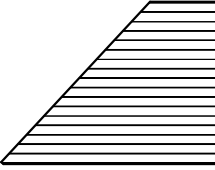
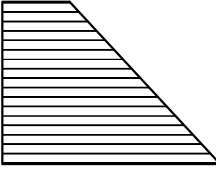
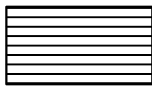

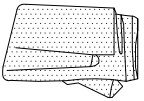
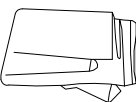

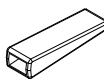

J 4x



K 4x

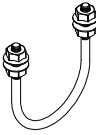

K1 4x

 L 1x	 M 1x	 N 4x	 N1 6x
 P 4x	 Q 2x	 Q1 4x	 Q2 4x
 R 2x	 R1 4x	 R2 4x	 S 4x
 T 4x	 U 112x	 V 4x	 Y 20x
 Y1 12x	 Z 2x	 S4 1x	
 M6x15 1 103x	 M6x10 2 32x	 M5x12 3 48x	 ST4.8x12 4 24x
 5 2x	 ST4x8 7 12x	 8 12x	 10 1x

<1>

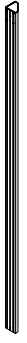

A 4x

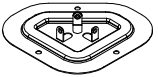

J 4x



3 12x M5x12

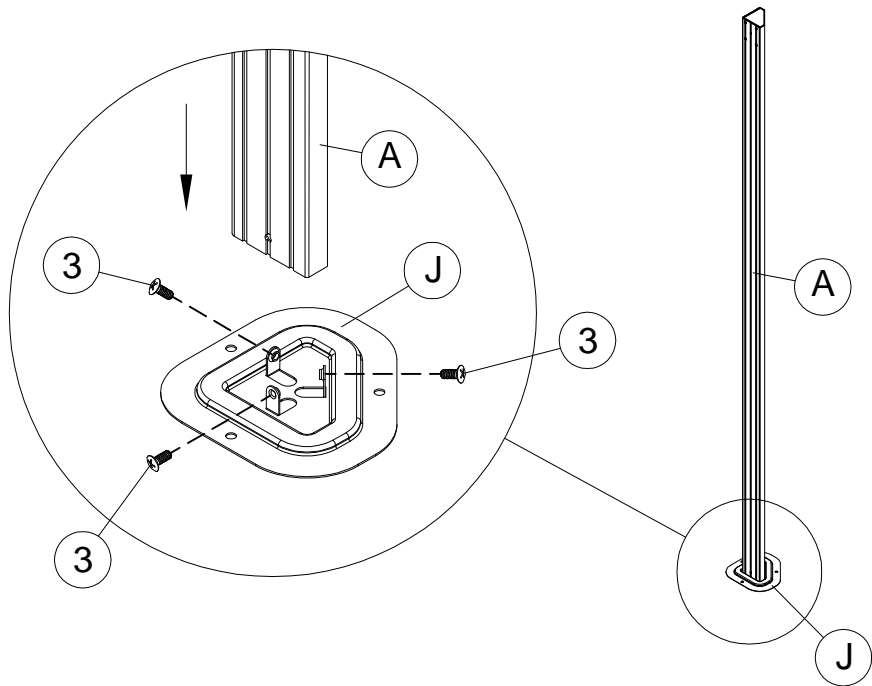

4

<2>

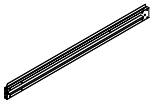

B 2x

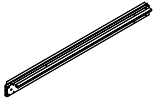

B1 2x

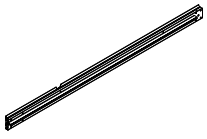

C 2x

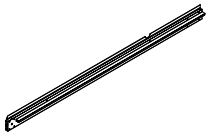

C1 2x

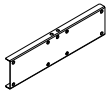

P 4x



1 42x M6x15

5

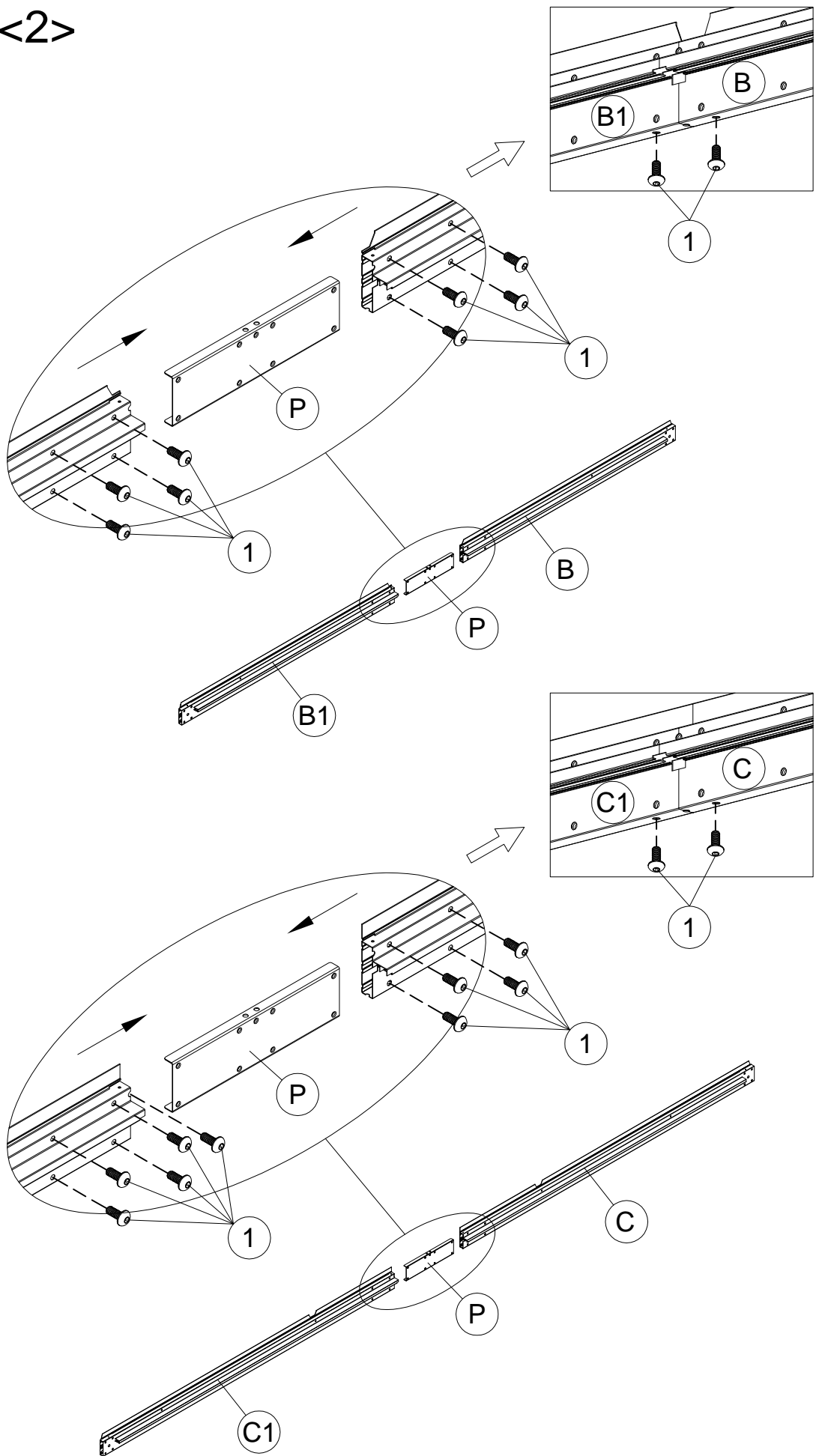



2 32x

M6x10

<3>

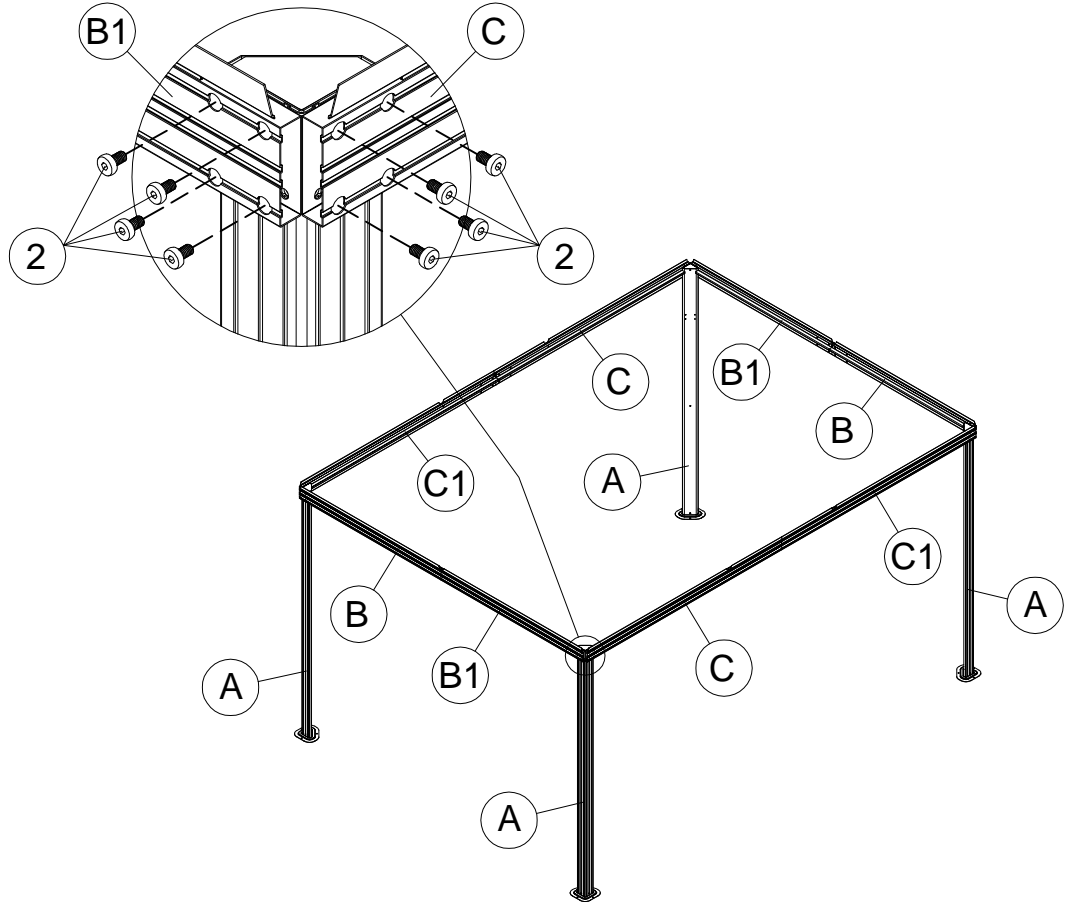

H1 4x

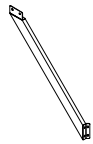

H2 4x



3 32x

M5x12

<4>

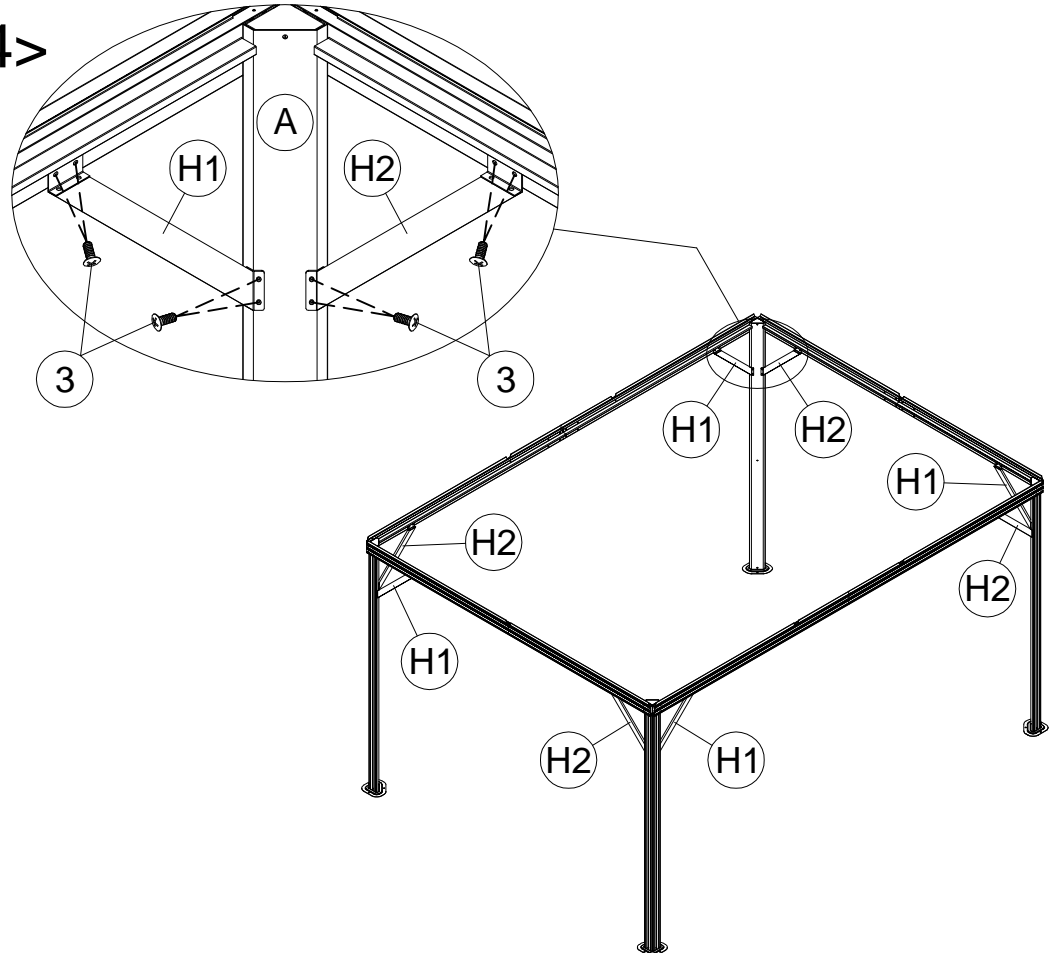

6



<5>

(H) 4x



(1) 8x M6x15

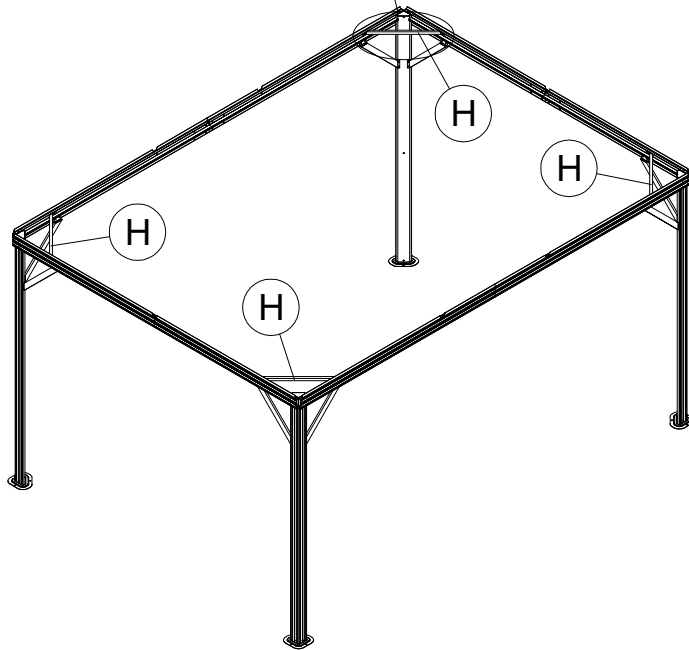
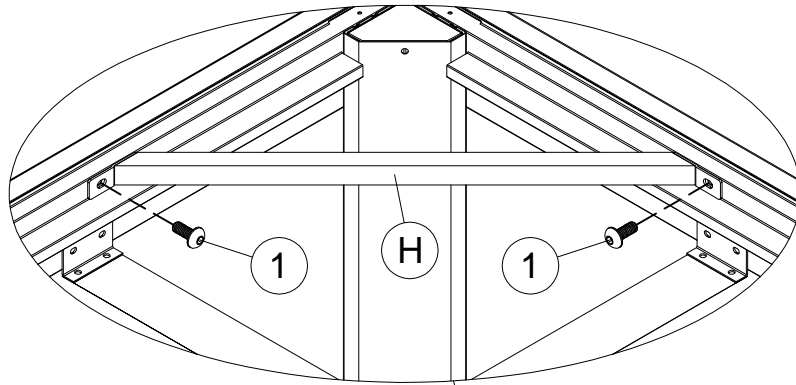

7





(K) 4x



(K1) 4x



(U) 112x



(V) 4x



(3) 4x M5x12



(4) 24x ST4.8x12

<6>

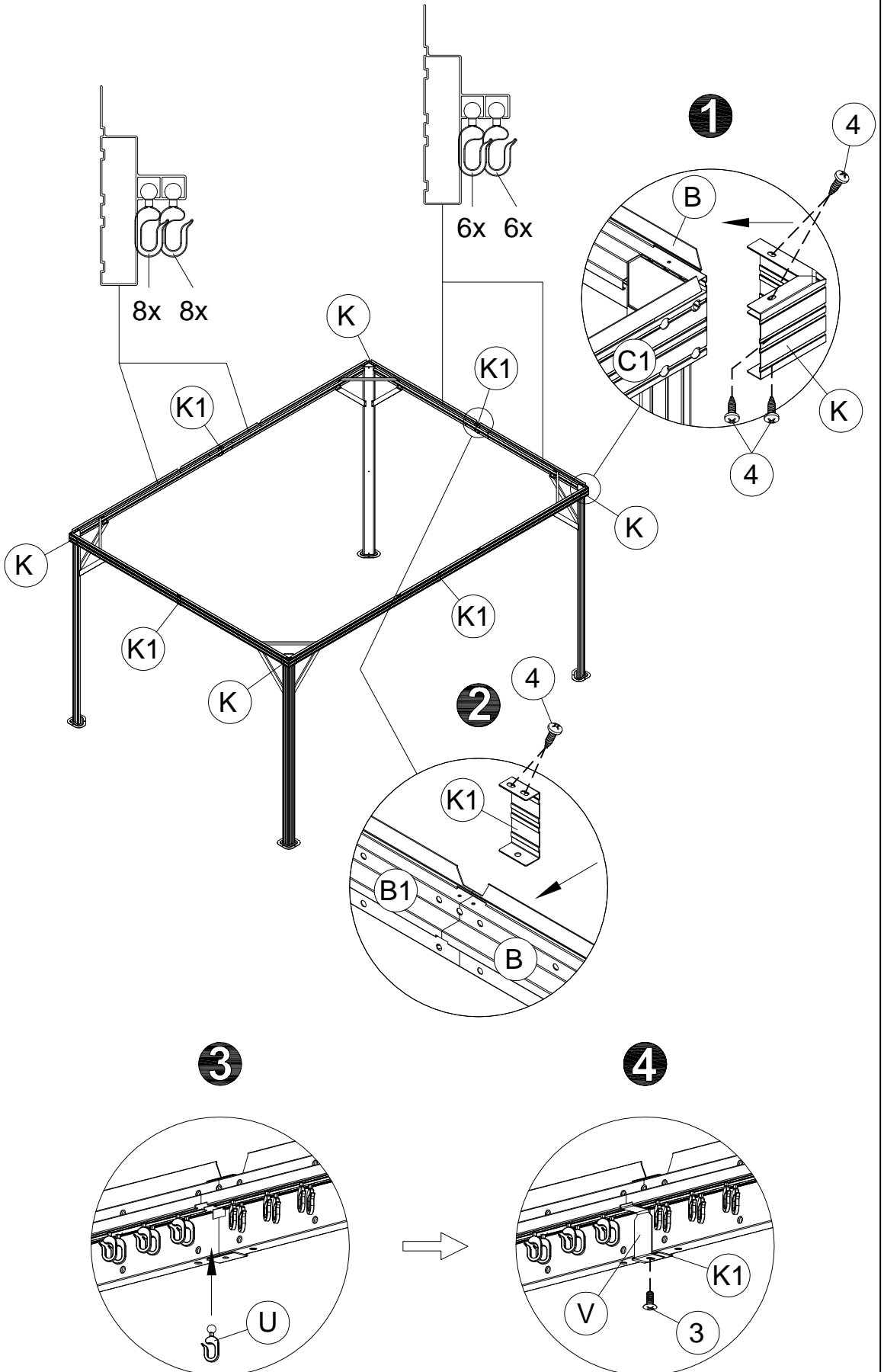

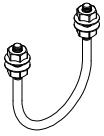

<7>

10 1x

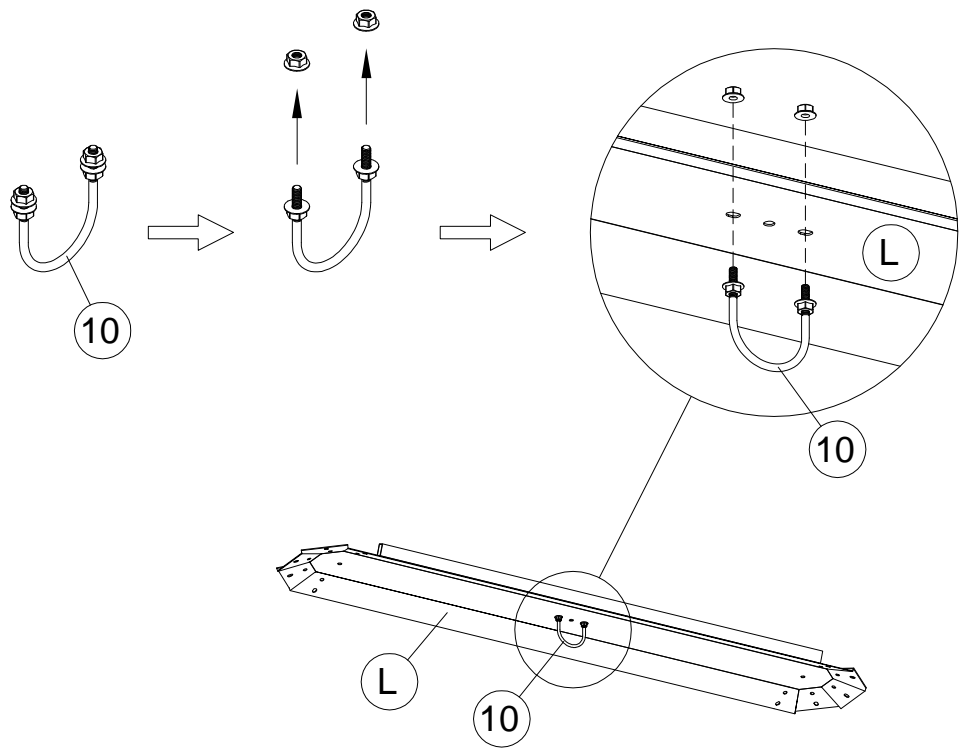



<8>

D 4x

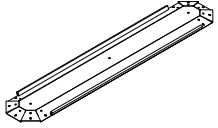

L 1x



1 12x M6x15

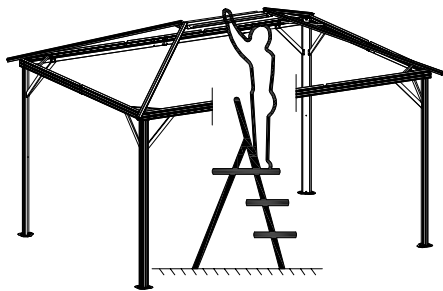
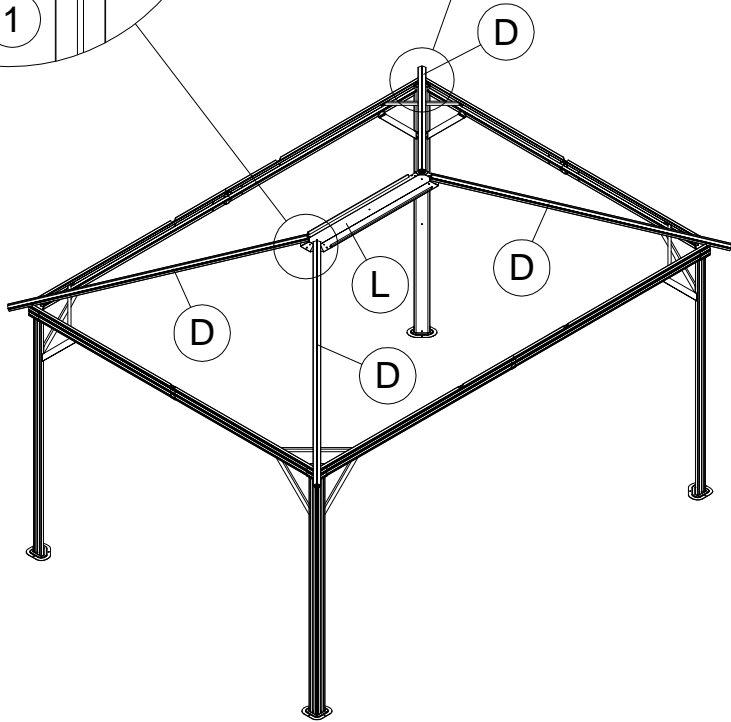
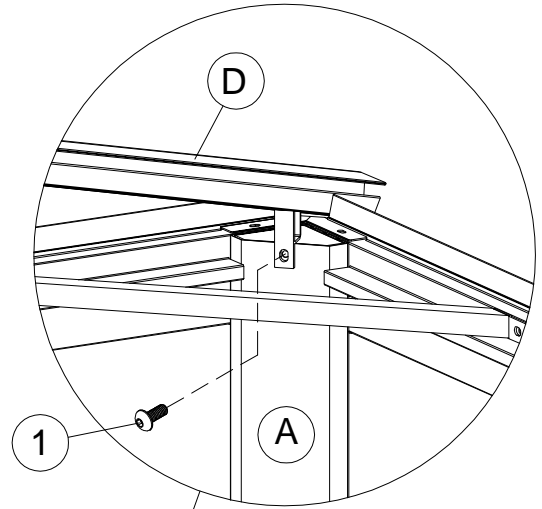
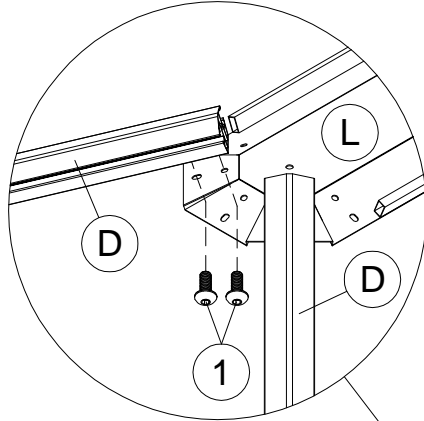

Note:

1. Let one person stand on the ladder to lift " L " and hold, and let others fasten the screws connecting both ends of " D ".

2. Please do not let go of holding " L " until all the " D " screws are installed.



<9>

E 6x



1 M6x15  
18x

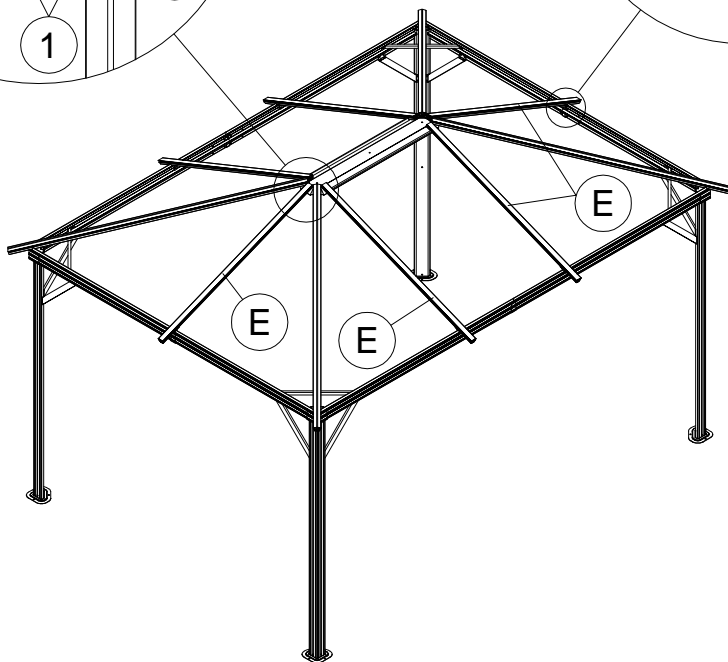
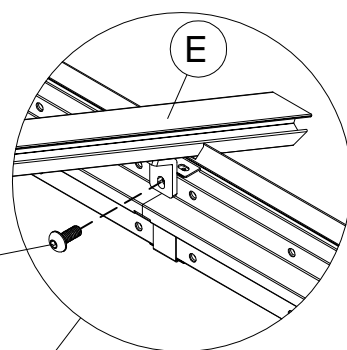
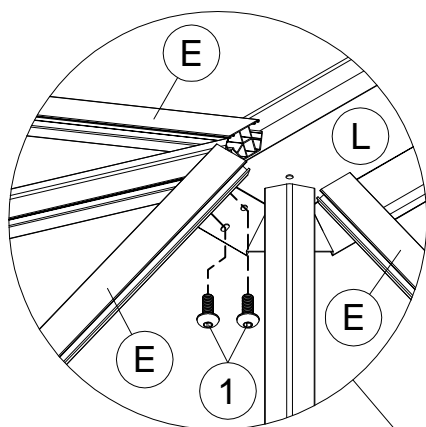

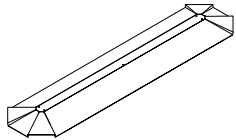

(M) 1x



(Z) 2x



(1) 3x M6x15



(5) 2x

<10>

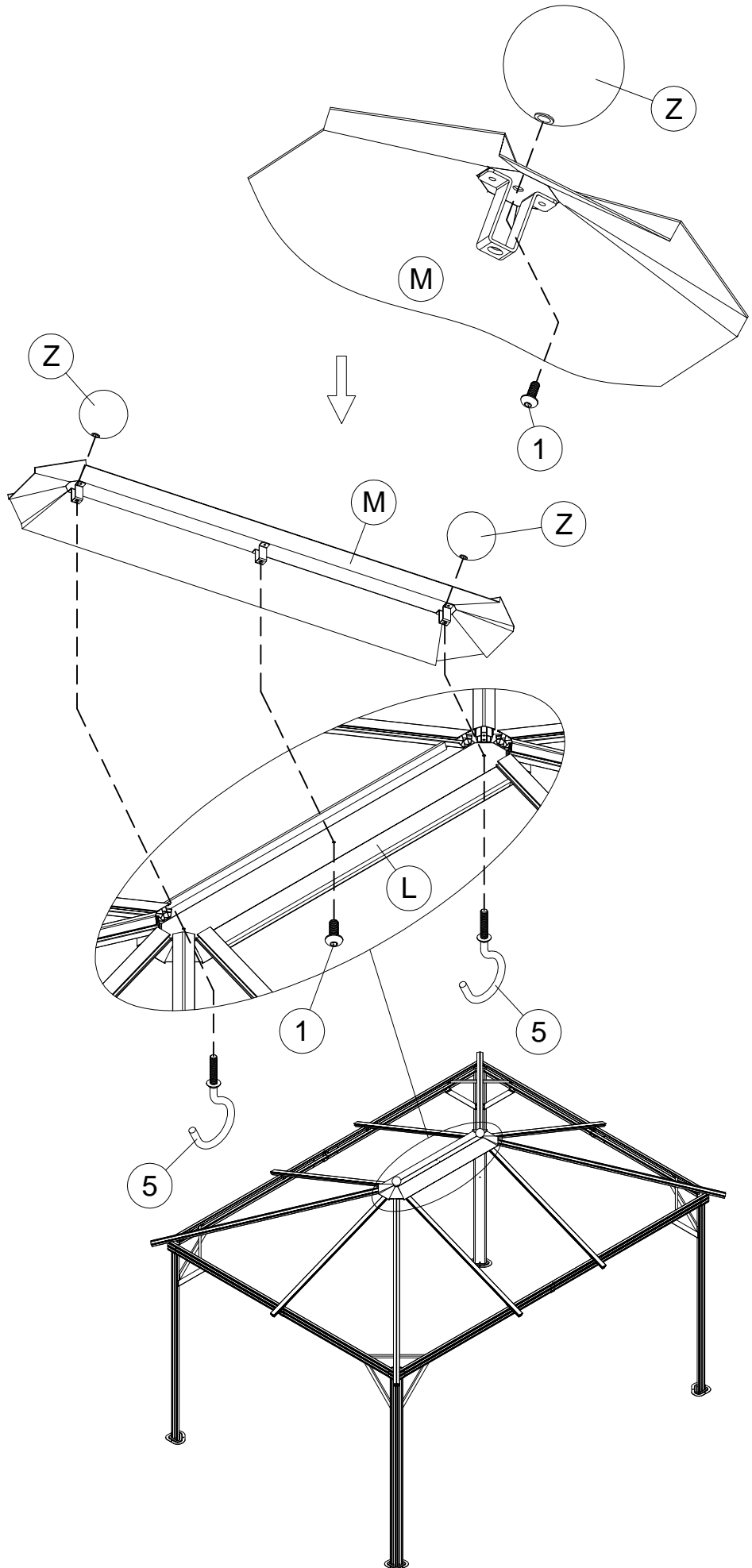

<11>

F 2x

F1 4x

F2 4x

1 10x M6x15

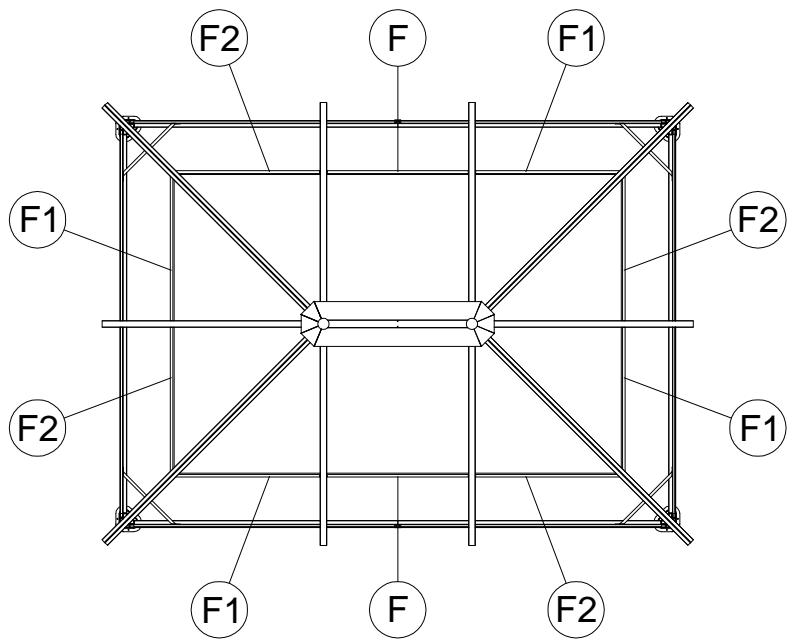
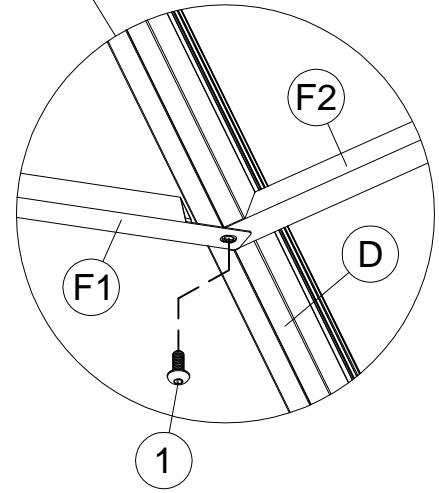
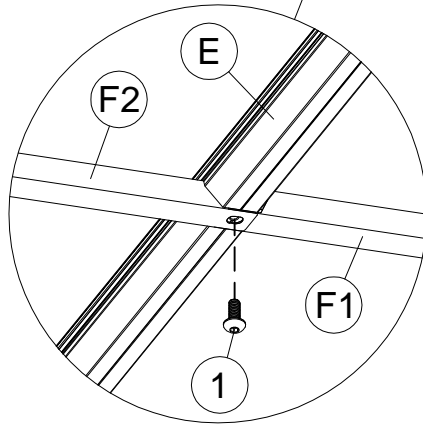
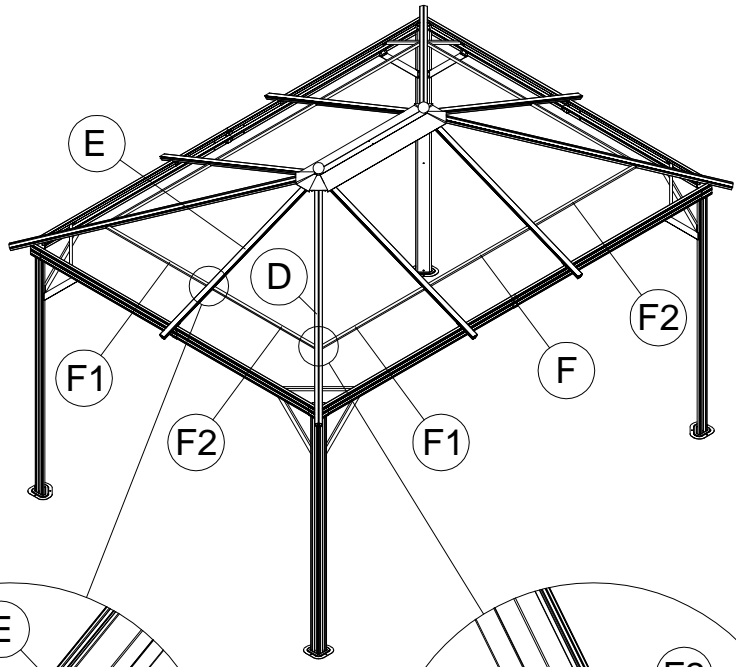

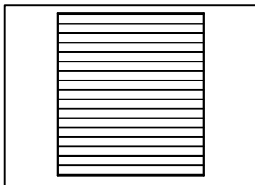

Q 2x

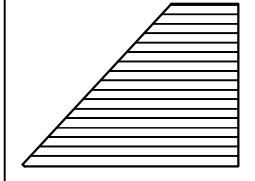

Q1 4x

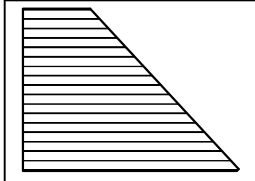

Q2 4x

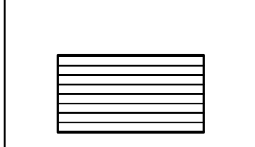

R 2x

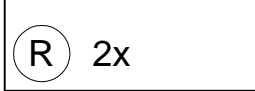

G 2x

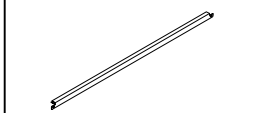

G1 4x

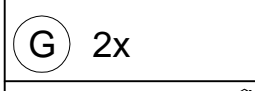

G2 4x

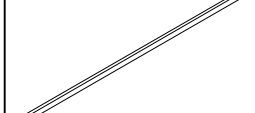

N 4x

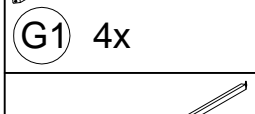

N1 6x

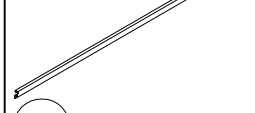

Y 4x

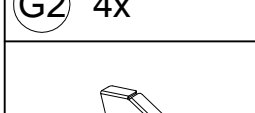

1 10x M6x15



14

<12>

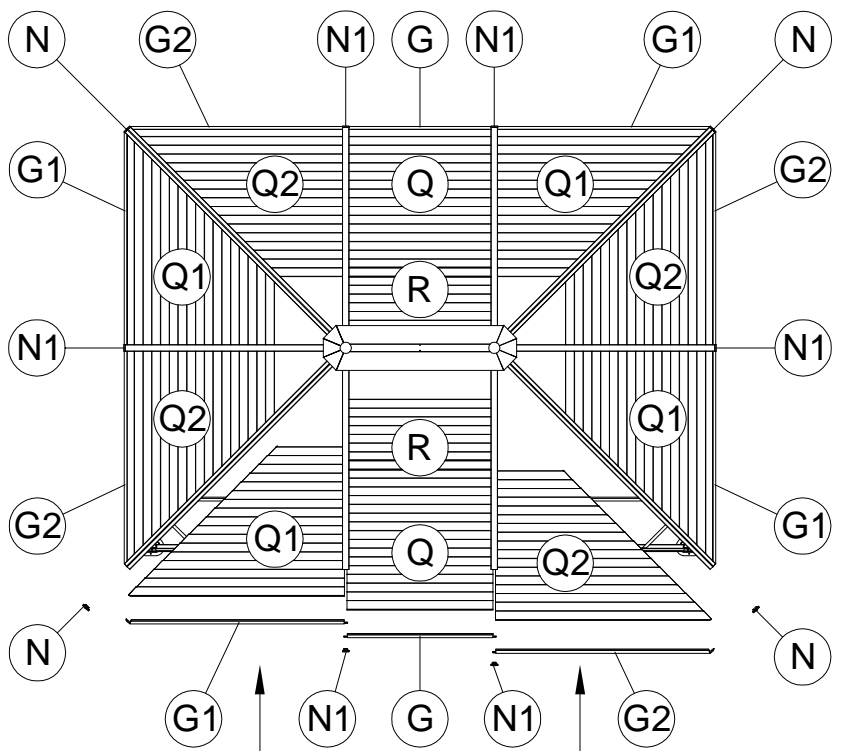
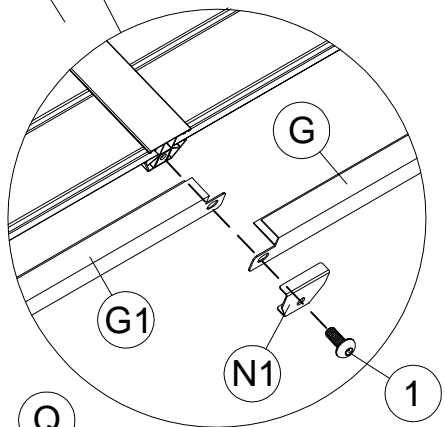
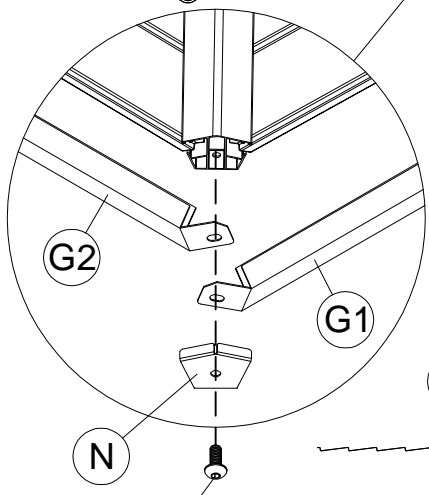
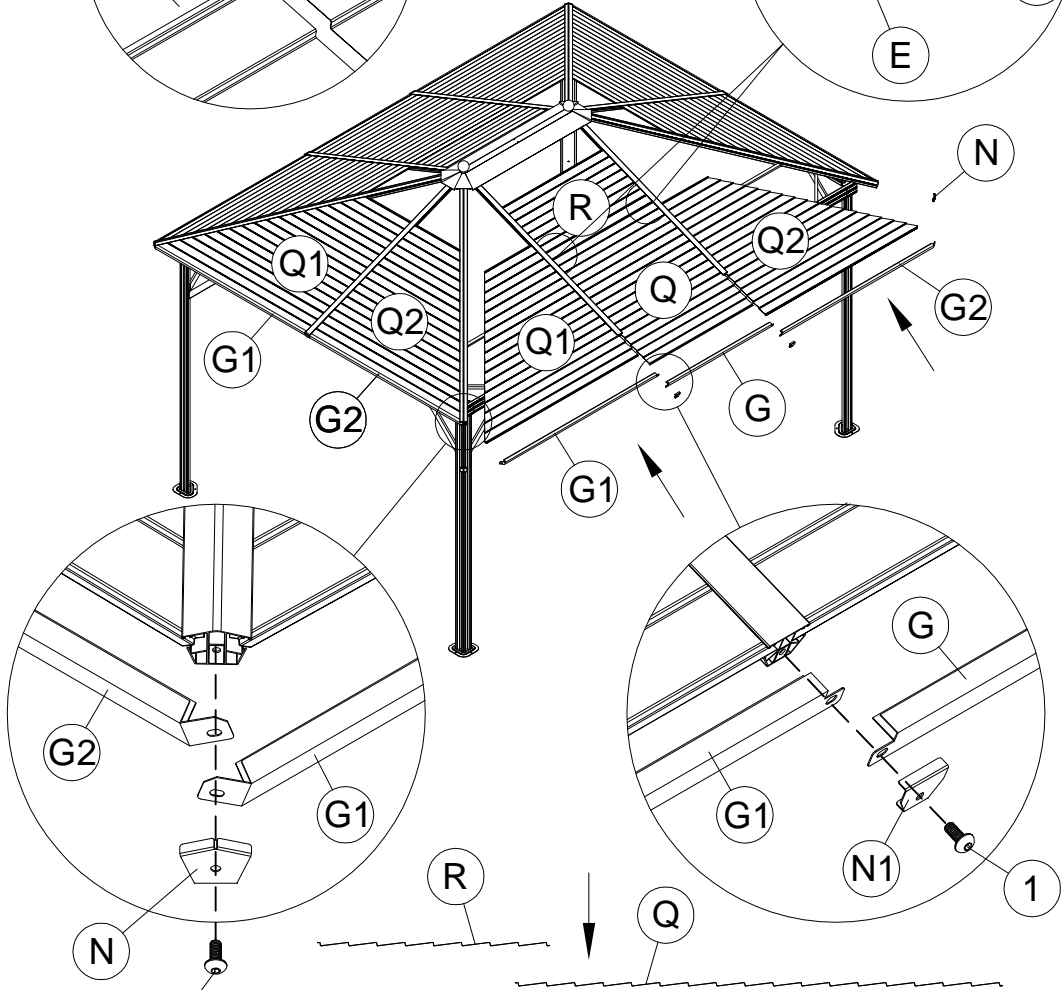
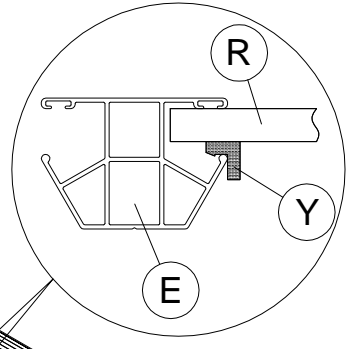
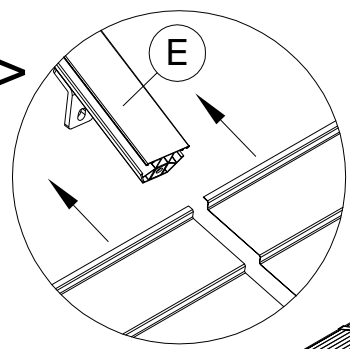



R1 4x



R2 4x

<13>

R1 or R2 or R

Q1 or Q2 or Q

D or E

Y

R1

Q1

Q2

R2

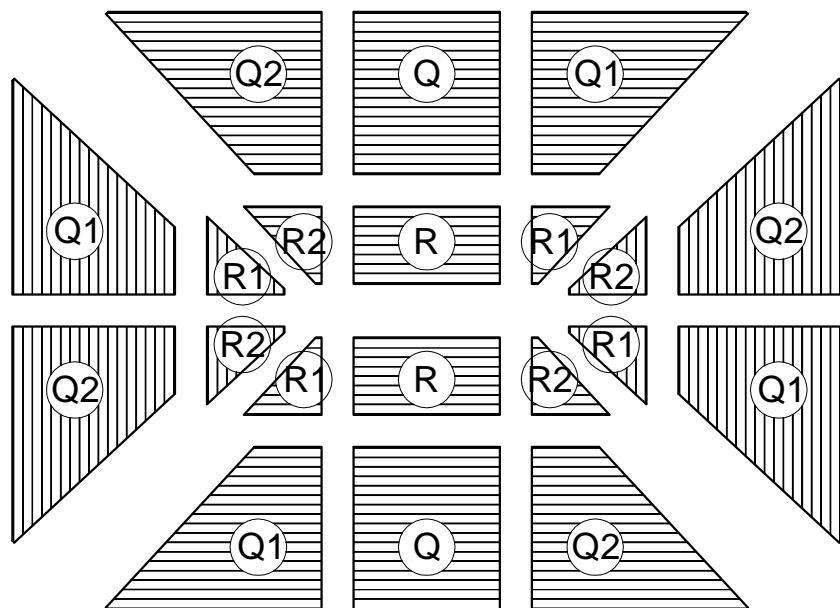
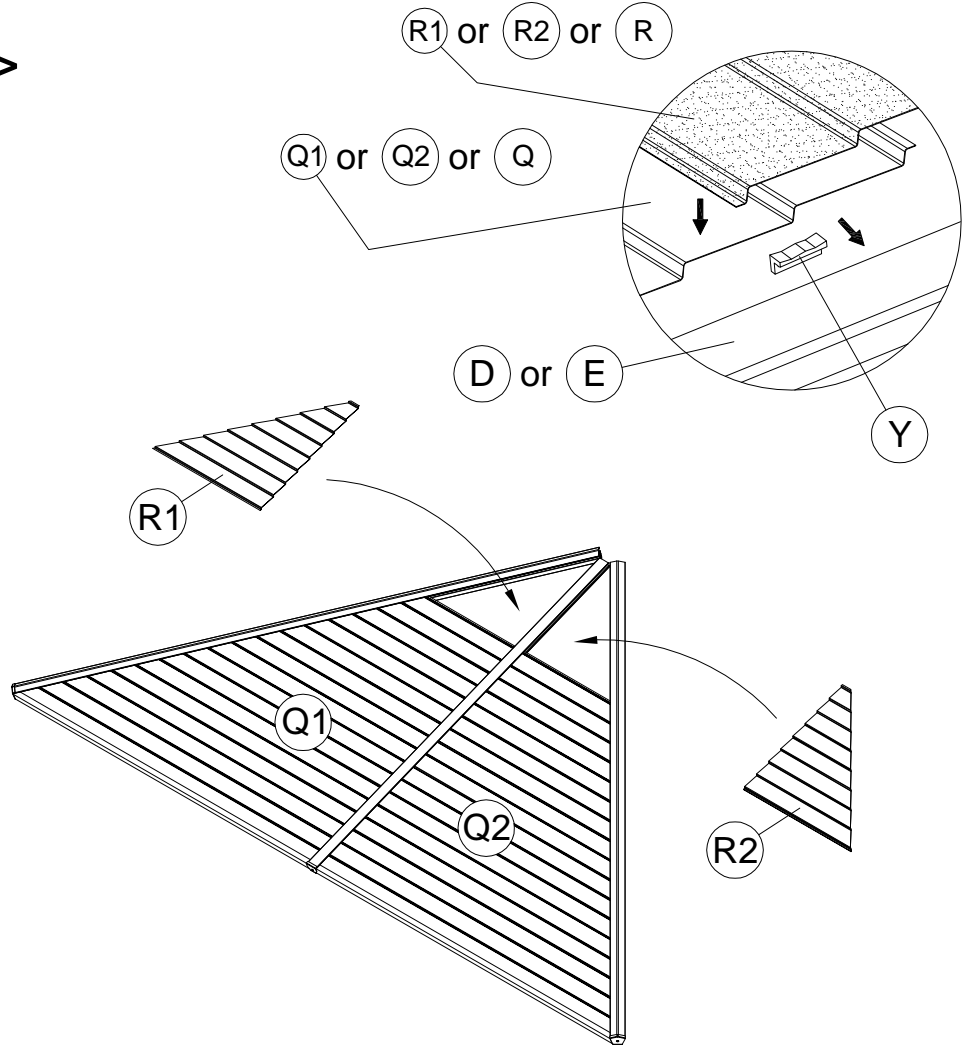





Y 16x

<14>

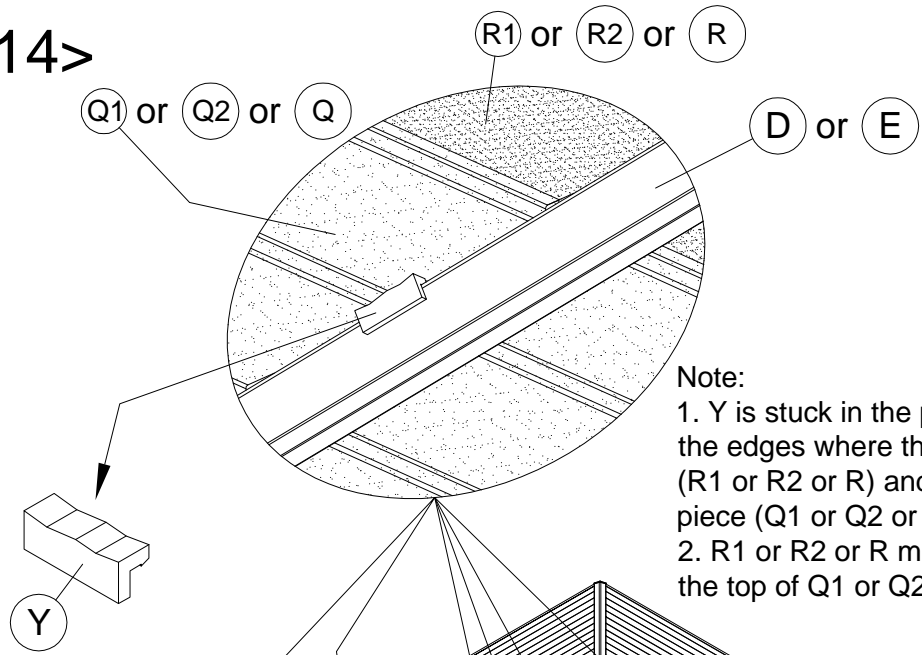

Note:

1. Y is stuck in the position of the edges where the small piece (R1 or R2 or R) and the large piece (Q1 or Q2 or Q) overlap.
2. R1 or R2 or R must pile up on the top of Q1 or Q2 or Q.

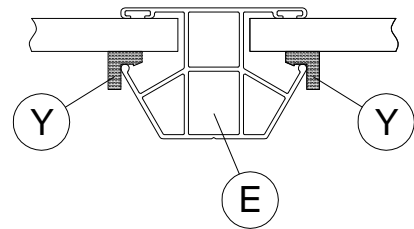
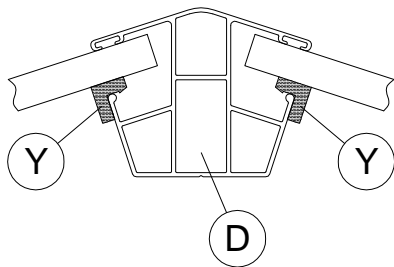
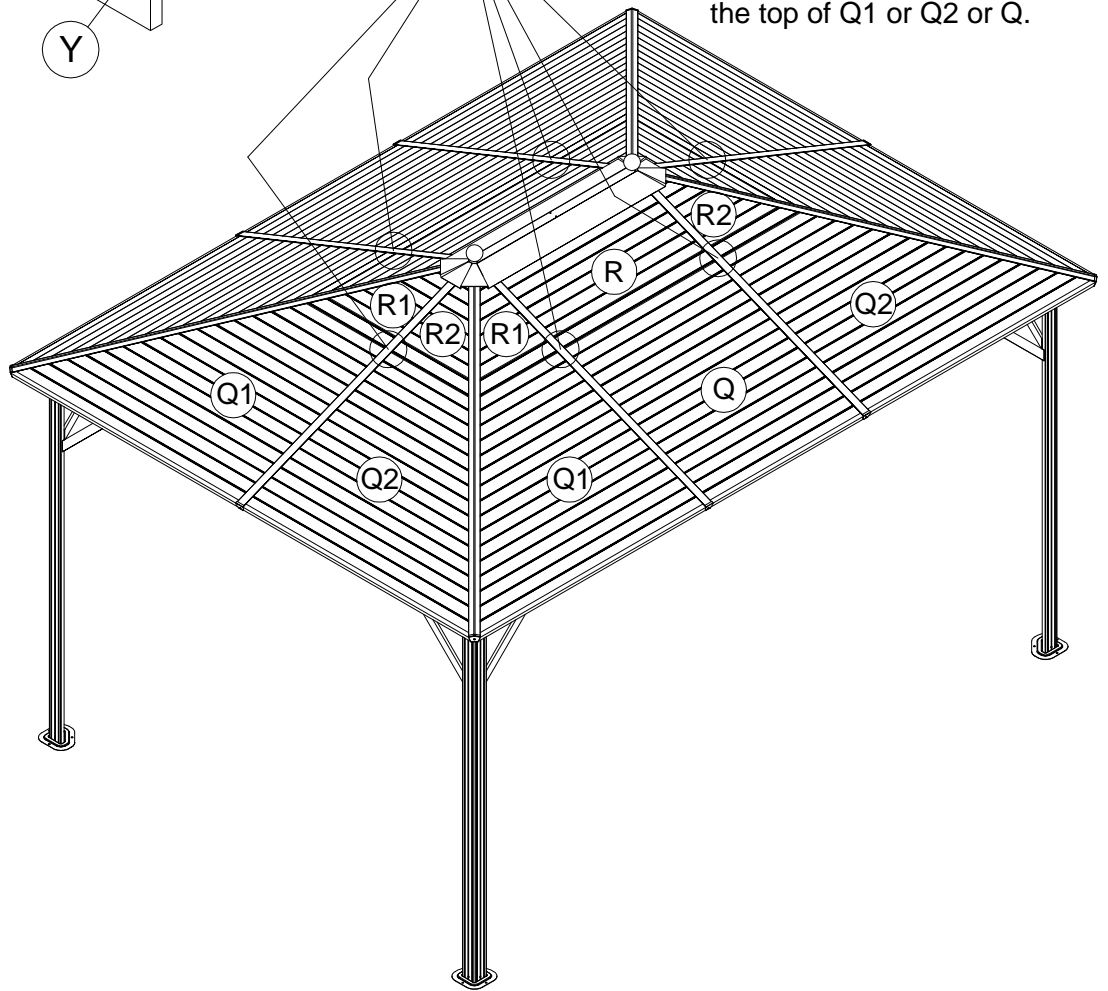

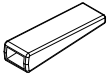

<15>

Y1 12x



7 ST4x8  
12x

Note: pls use power tools to drill the screws.

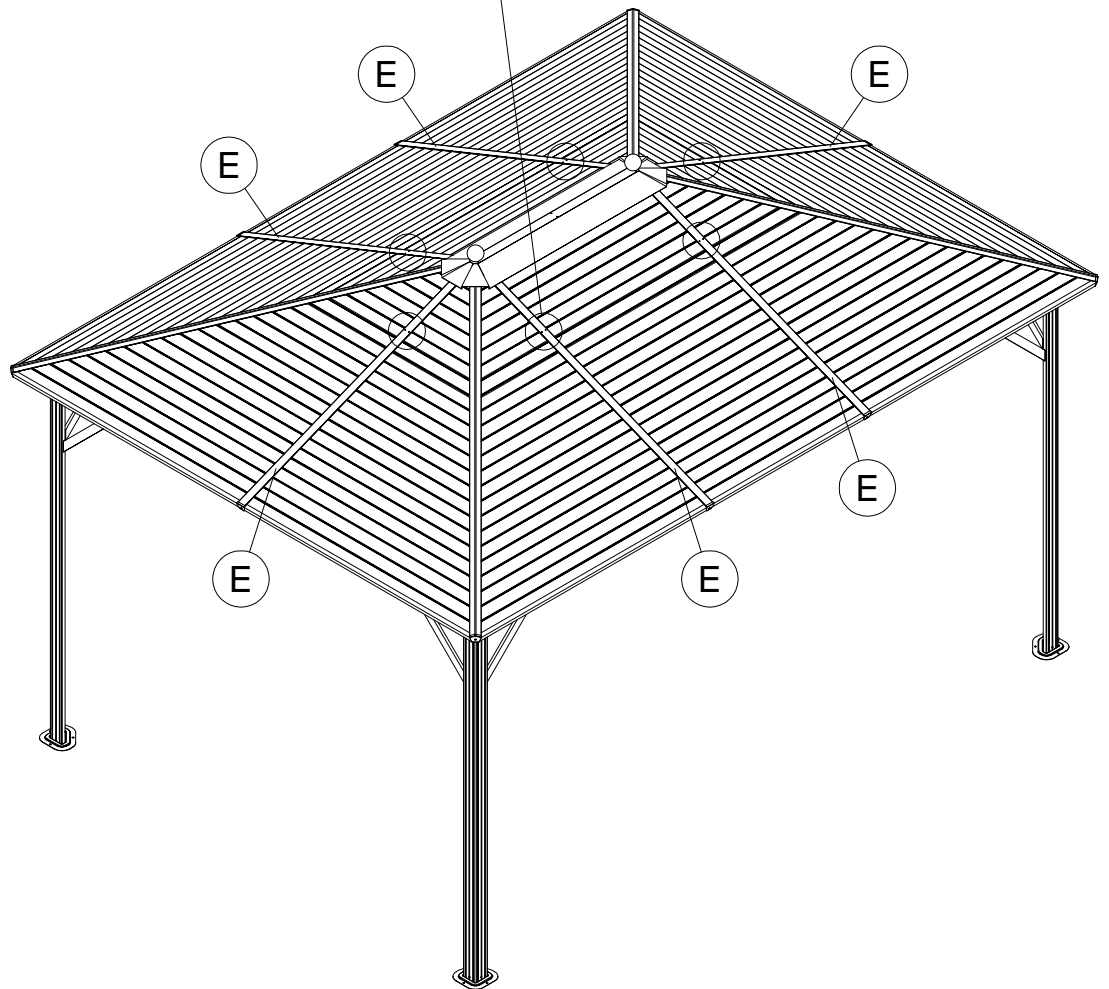
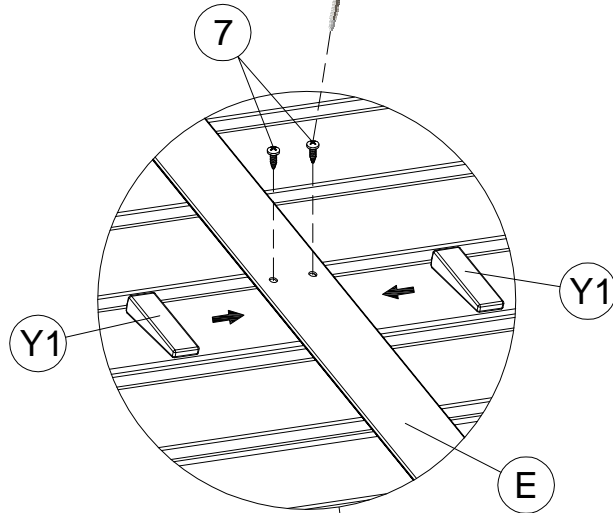
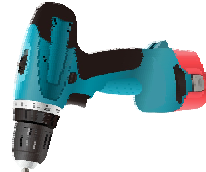

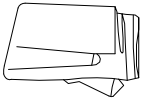

<16>

T 4x

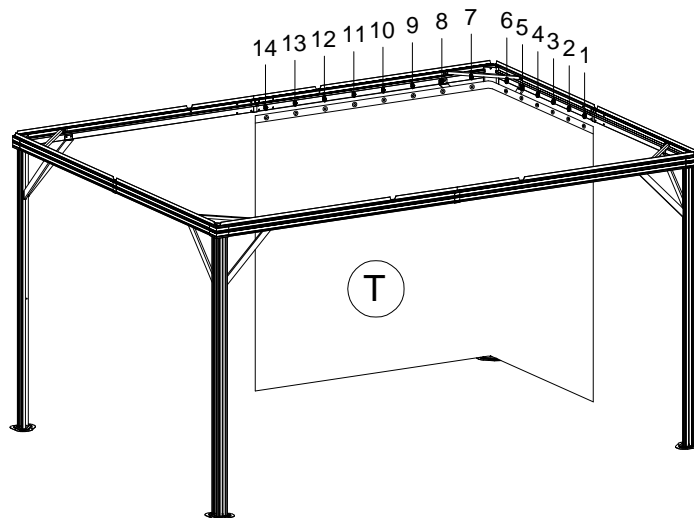
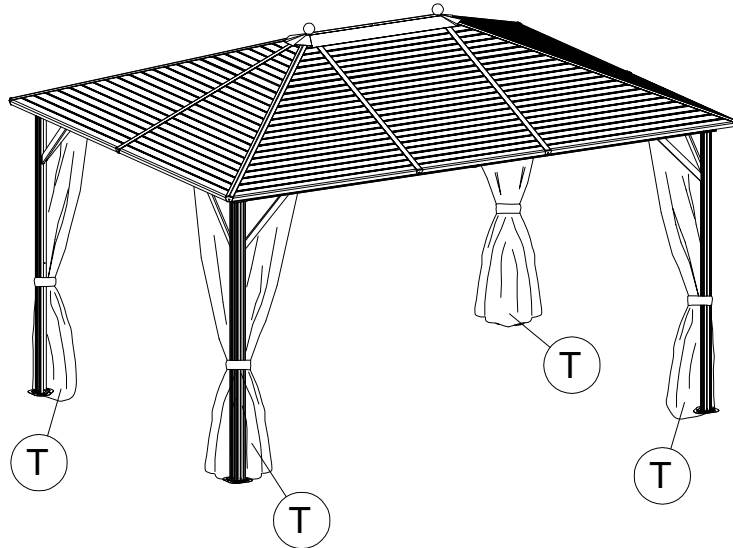
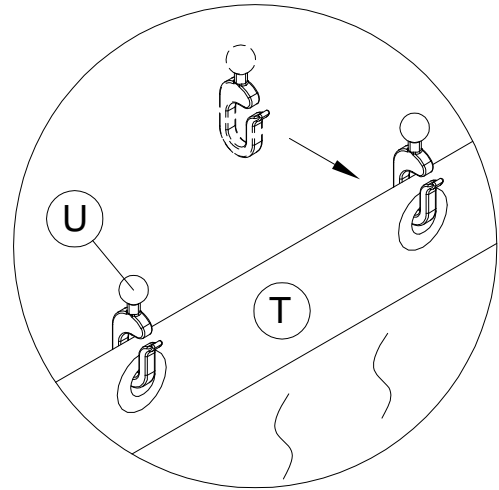
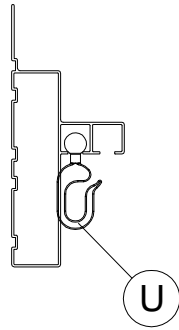

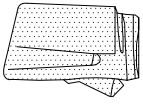

<17>

S 4x

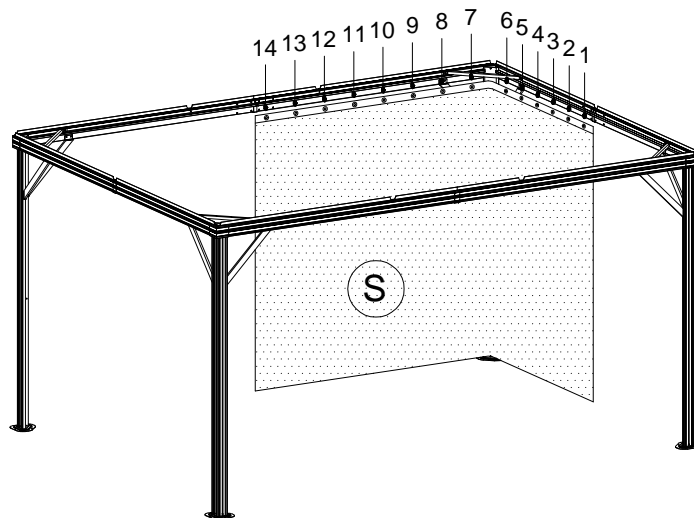
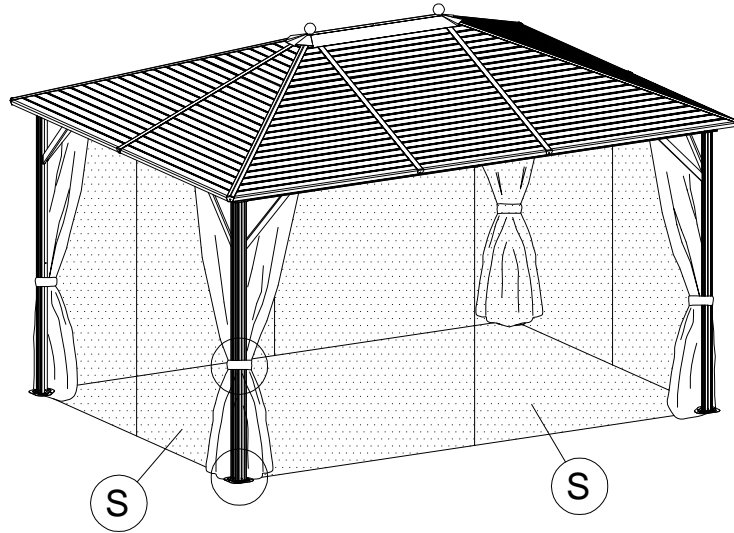
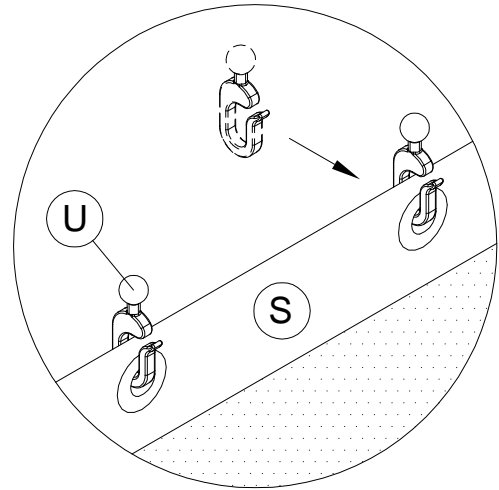
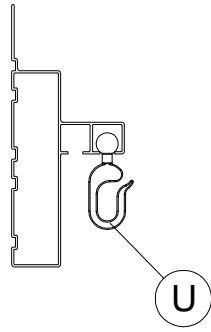



<18>

8 12x

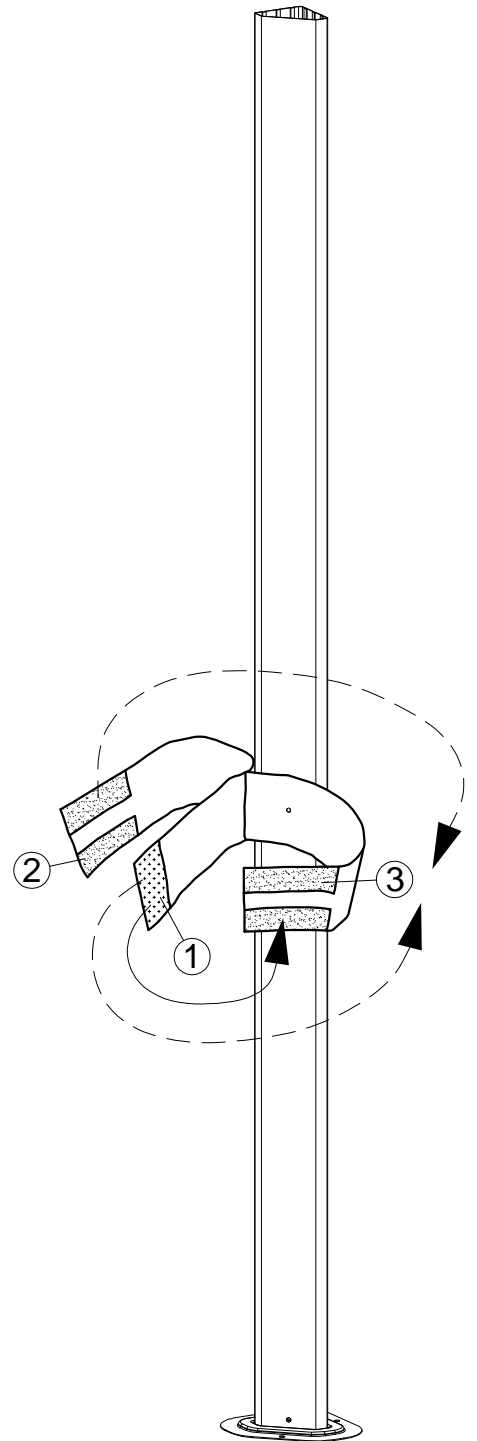
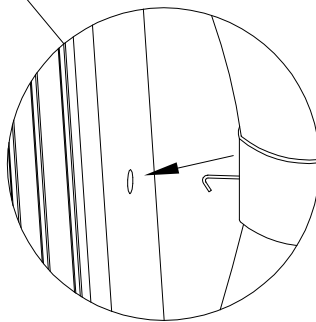
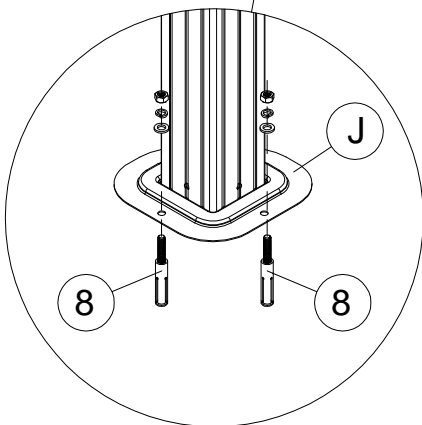
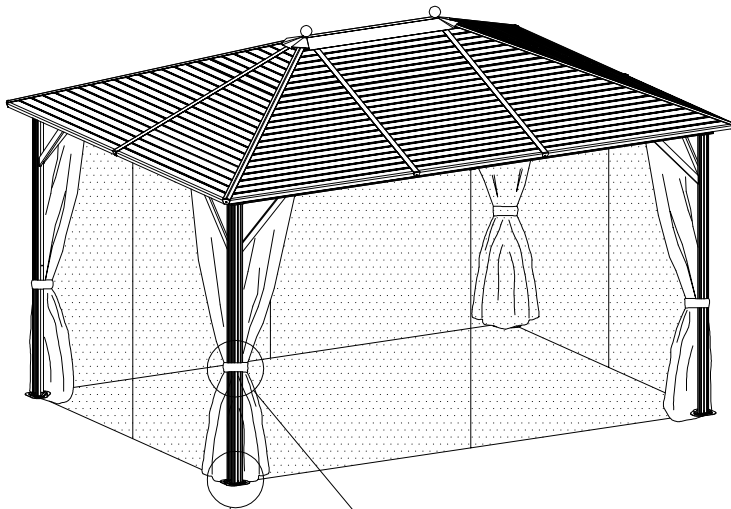

Note:

1. 1 stick 2 tie S and T together
2. 1 stick 3 towards back tie T
3. 1 stick 3 towards front tie S

20