

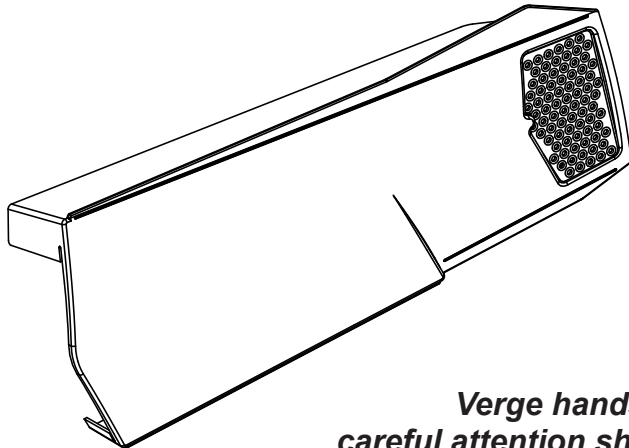

**Left Hand
Dry Verge Unit
(GPPV-LH)**

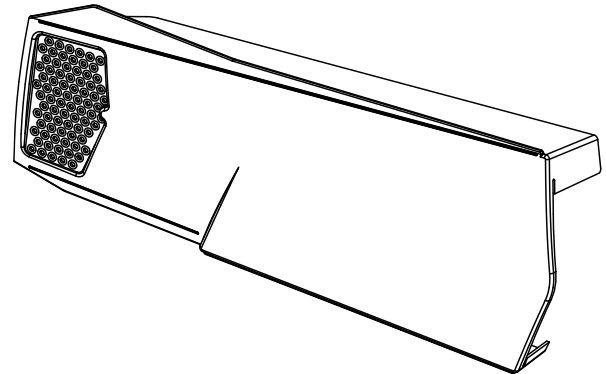

**Right Hand
Dry Verge Unit
(GPPV-RH)**



Verge hands are assigned from the 'roofer's perspective', careful attention should be taken when specifying 'Right' & 'Left'.

Description

The SmartVerge Polypropylene dry verge system is a fast and effective method for finishing the verge of roof that has been fitted with small or large format, interlocking tiles. The individual verge units cap the end of each course of tiles to provide an unobtrusive, weatherproof cover whilst preserving the 'stepped' appearance of the roof tiles at the verge.

The system is mechanically fixed and can be installed in all weather conditions without the need for mortar.

The units have been designed to be compatible with both small and large format interlocking tile types that are available in the UK.

Features

- Fast and easy to install, dry fix verge system.
- Suits small and large format concrete interlocking tiles.
- Can be fitted with a batten gauge of 255mm to 345mm.
- Provides a mechanically fixed, mortar-free solution.
- Protects the verge from exposure to the elements.
- Also helps to prevent the entry of birds and large insects.
- Suitable for both new build and refurbishment details.
- Can be installed on roof pitches between 15° and 55°.
- Drains moisture away from the wall to prevent staining.
- Manufactured from UV stabilised polypropylene.
- Available in a range of colours to suit various roof types.
- Meets BS 5534 requirements for mechanical fixing.
- System independently wind tunnel tested at the BRE.

BS 8612 Specifications

- Independently tested to conform with the requirements of BS 8612.
- Performance data for the tests conducted on this product is available upon request.

MANTHORPE BUILDING PRODUCTS LTD
MANTHORPE HOUSE
BRITAIN DRIVE
CODNOR GATE BUSINESS PARK
RIPLEY
DERBYSHIRE DE5 3ND

TEL: 01773 303 000
FAX: 01773 303 300
EMAIL:
mbp.care@manthorpebp.co.uk
WEB
www.manthorpebp.co.uk

DRN K.B. Date 20.06.19

The company maintains a policy of continuous development of its product range and reserves the right to amend the specification without notice.

DRG No

MBP 8326

Issue

C

(1 of 2)

SmartVerge Polypropylene Dry Verge Units

CODE **GPPV**

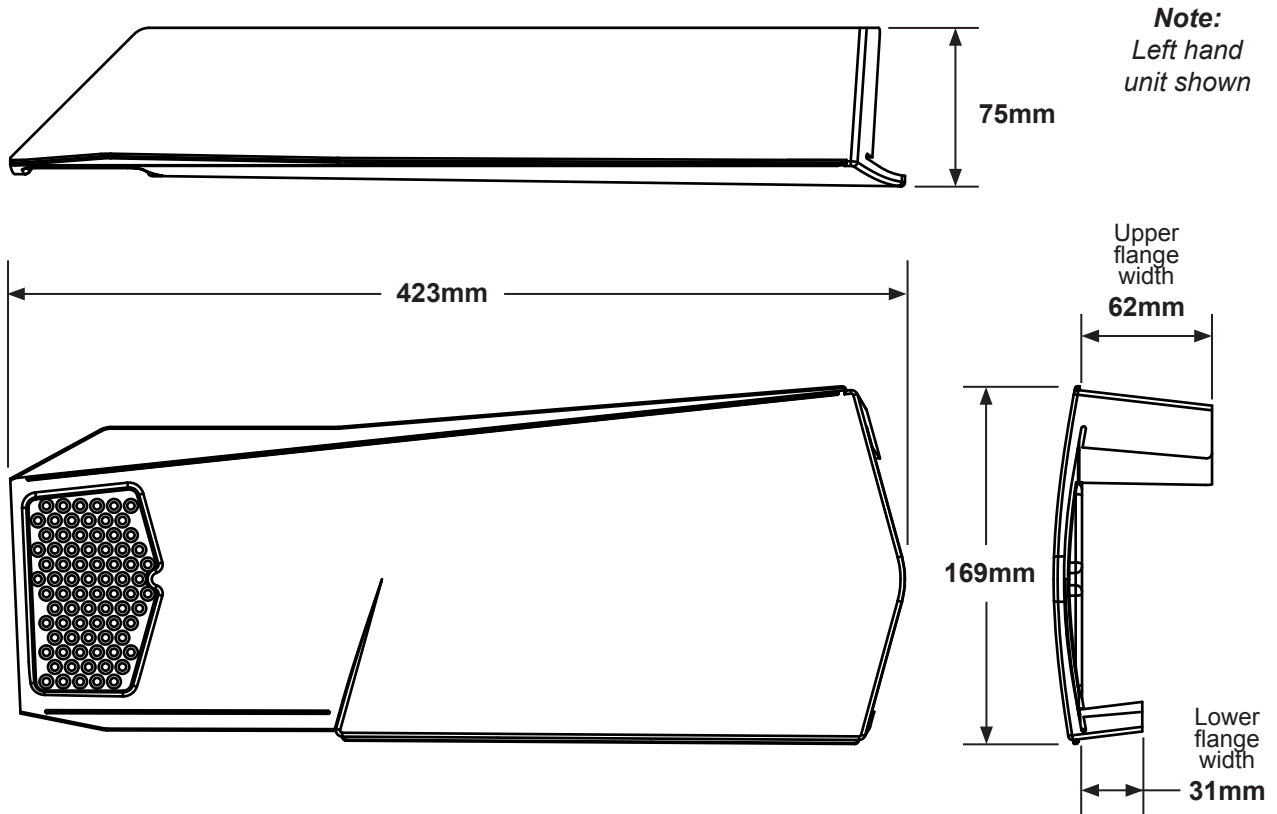

Tile Size Compatibility	Small (382 x 227mm) Large (418 x 330mm) XL (430 x 380mm)
Batten Gauge Range	255mm to 345mm
Roof Pitch Range	15° to 55°
Verge Overhang	30mm (minimum)

References	
BSI: BS 5534:2014 Code of Practice for Slating and Tiling	
BRE: Test report number P110111-1000	
BSI: BS 8612:2018	
NHBC: Standards - Chapter 7.2 Pitched Roofs	

Packing Details	50 per box. Packed in bags of 10 Left <u>or</u> Right hand verge units. 5 bags per box.
Box Weight	11.5 kg (approx.)
Part Weight	0.219 kg
Material	Polypropylene
Manufacturing Process	Injection Moulded
Colours	(TR) Terracotta (BR) Dark Brown (GR) Slate Grey (BL) Black

MANTHORPE BUILDING PRODUCTS LTD
MANTHORPE HOUSE
BRITAIN DRIVE
CODNOR GATE BUSINESS PARK
RIPLEY
DERBYSHIRE DE5 3ND

TEL: 01773 303 000
FAX: 01773 303 300
EMAIL: mbp.care@manthorpebp.co.uk
WEB: www.manthorpebp.co.uk

DRN K.B. Date 20.06.19
The company maintains a policy of continuous development of its product range and reserves the right to amend the specification without notice.

DRG No
MBP 8326

Issue
C
(2 of 2)