

Combination Cavity Sleeve

CODE **G935**

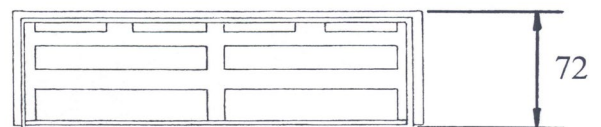
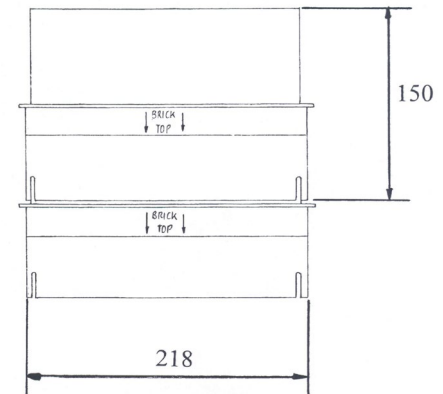
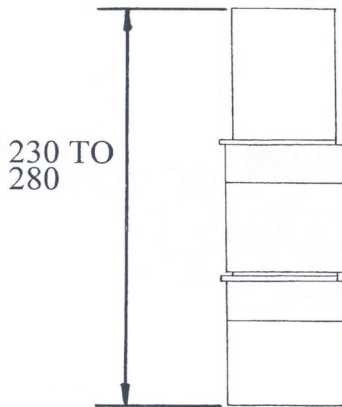
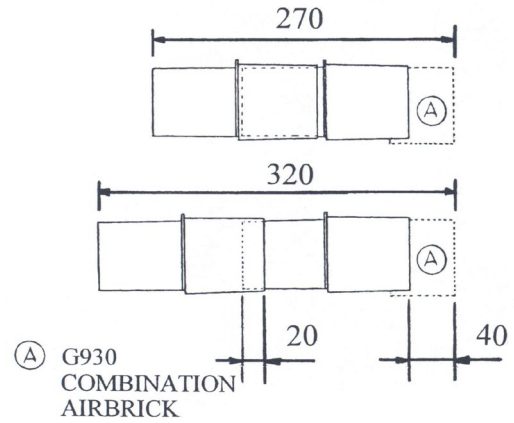
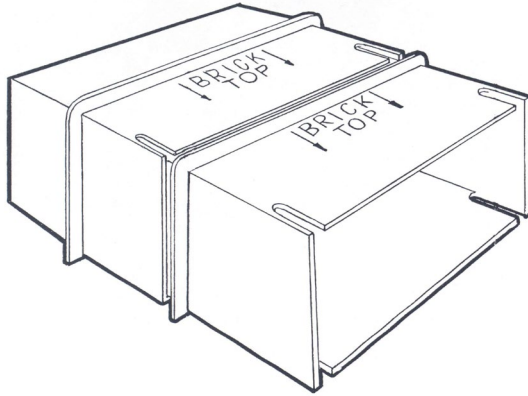

Description:

The G935 Combination Cavity Sleeve is designed to fit to the back of a G930 Combination Airbrick 9" x 3". Alternatively it can be stacked to form 9" x 6" or 9" x 9" formations.

A telescopic ability enables the G935 to adjust to fit cavity widths of 50mm to 100mm. Further horizontal extension is possible with the addition of extra units.

| | |
|-----------------------|----------------------------------|
| COLOURS | Black |
| PACKING DETAILS | Packed in 10's per cardboard box |
| WEIGHT | 1.7kg per box |
| MATERIAL | High Impact Styrene |
| MANUFACTURING PROCESS | Injection Moulded |
| FREE AIRFLOW | 6,600mm ² |

MANTHORPE BUILDING PRODUCTS LTD
 MANTHORPE HOUSE
 BRITAIN DRIVE
 CODNOR GATE BUSINESS PARK
 RIPLEY
 DERBYSHIRE DE5 3ND

TEL: 01773 303 000
 FAX: 01773 303 300
 EMAIL: mbp.care@manthorpebp.co.uk
 WEB: www.manthorpebp.co.uk

DRN M.L.W.O | Date 05.07.19
 The company maintains a policy of continuous development of its product range and reserves the right to amend the specification without notice.

DRG No
MBP 8055
 Issue
B