

Sleeve-All® Sleeve Anchor

Sleeve-All expanding anchors are pre-assembled, expanding sleeve anchors for use in all types of solid base materials. This anchor is available in acorn, hex, rod coupler or flat head style for a wide range of applications.

Codes: FM 3017082, 3026805 and 3029959 (carbon steel 3/8" – 1/2" diameter); Underwriters Laboratories File Ex3605 (3/8" – 3/4" diameter); Multiple DOT listings; meets the requirements of Federal Specification A-A-1922A

Material: Carbon steel or Type 304 stainless steel

Coating: Carbon steel anchors are zinc plated

Installation

1. Drill a hole in the base material using a carbide drill bit the same diameter as the nominal diameter of the anchor to be installed.
2. Drill the hole to the specified embedment depth, and blow it clean using compressed air. (Overhead installations need not be blown clean.) Alternatively, drill the hole deep enough to accommodate embedment depth and the dust from drilling.
3. Place the anchor in the fixture, and drive it into the hole until the washer and nut are tight against the fixture.
4. Tighten to required installation torque.

 **Caution:** Oversized holes will make it difficult to set the anchor and will reduce the anchor's load capacity.

Installation Sequence

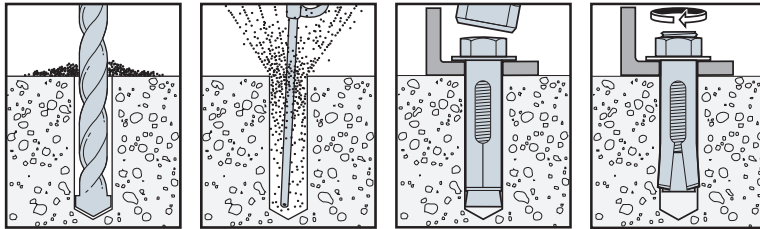

Material Specifications

| Anchor Component | Zinc-Plated Carbon Steel | Stainless Steel |
|------------------|---|-----------------|
| Anchor Body | Material meets minimum 50,000 psi tensile | Type 304 |
| Sleeve | SAE J403, Grade 1008 cold-rolled steel | Type 304 |
| Nut | Commercial Grade, meets requirements of ASTM A563 Grade A | Type 304 |
| Washer | SAE J403, Grade 1008/1010 cold-rolled steel | Type 304 |

Sleeve-All Anchor Installation Data

| Sleeve-All Diameter (in.) | 1/4 | 5/16 | 3/8 | 1/2 | 5/8 | 3/4 |
|-----------------------------------|-----|------|-----|------|-----|-------|
| Installation Torque (ft.-lb.) | 5 | 8 | 15 | 25 | 50 | 90 |
| Drill Bit Size (in.) | 1/4 | 5/16 | 3/8 | 1/2 | 5/8 | 3/4 |
| Wrench Size ¹ (in.) | 3/8 | 7/16 | 1/2 | 9/16 | 3/4 | 15/16 |
| Wrench Size for Coupler Nut (in.) | | | 1/2 | 5/8 | 3/4 | — |

1. Applies to acorn- and hex-head configurations only.



Hex

Acorn



Rod Coupler

Flat Head
(Phillips drive)



Sleeve-All® Sleeve Anchor

Sleeve-All Anchor Product Data — Zinc-Plated Carbon Steel

| Size (in.) | Model No. | Head Style | Bolt Diameter – Threads per Inch | Max. Fixture Thickness (in.) | Quantity | | |
|--------------|-----------|------------|----------------------------------|------------------------------|----------|--------|-----|
| | | | | | Box | Carton | |
| 1/4 x 1 3/8 | SL25138A | Acorn Head | 3/16-24 | 1/4 | 100 | 500 | |
| 1/4 x 2 1/4 | SL25214A | | | 1 1/8 | 100 | 500 | |
| 5/16 x 1 1/2 | SL31112H | Hex Head | 1/4-20 | 3/8 | 100 | 500 | |
| 5/16 x 2 1/2 | SL31212H | | | 1 1/16 | 50 | 250 | |
| 3/8 x 1 7/8 | SL37178H | | 5/16-18 | 3/8 | 50 | 250 | |
| 3/8 x 3 | SL37300H | | | 1 1/2 | 50 | 200 | |
| 3/8 x 4 | SL37400H | | | 2 1/4 | 50 | 200 | |
| 1/2 x 2 1/4 | SL50214H | | | 3/8-16 | 1/2 | 50 | 200 |
| 1/2 x 3 | SL50300H | | 3/4 | | 25 | 100 | |
| 1/2 x 4 | SL50400H | | 1 3/4 | | 25 | 100 | |
| 1/2 x 6 | SL50600H | | 3 3/8 | | 20 | 80 | |
| 5/8 x 2 1/4 | SL62214H | | 1/2-13 | 1/2 | 25 | 100 | |
| 5/8 x 3 | SL62300H | | | 3/4 | 20 | 80 | |
| 5/8 x 4 1/4 | SL62414H | | | 1 1/2 | 10 | 40 | |
| 5/8 x 6 | SL62600H | | | 3 1/4 | 10 | 40 | |
| 3/4 x 2 1/2 | SL75212H | | | 5/8-11 | 1/2 | 10 | 40 |
| 3/4 x 4 1/4 | SL75414H | | | | 7/8 | 10 | 40 |
| 3/4 x 6 1/4 | SL75614H | | 2 7/8 | | 5 | 20 | |
| 1/4 x 2 | SL25200PF | | Phillips Flat Head | 3/16-24 | 7/8 | 100 | 500 |
| 1/4 x 3 | SL25300PF | | | | 1 7/8 | 50 | 250 |
| 5/16 x 2 1/2 | SL31212PF | 1/4-20 | | 1 1/16 | 50 | 250 | |
| 5/16 x 3 1/2 | SL31312PF | | | 2 1/16 | 50 | 250 | |
| 3/8 x 2 3/4 | SL37234PF | 5/16-18 | | 1 1/4 | 50 | 200 | |
| 3/8 x 4 | SL37400PF | | | 2 1/2 | 50 | 200 | |
| 3/8 x 5 | SL37500PF | | | 3 1/2 | 50 | 200 | |
| 3/8 x 6 | SL37600PF | | | 4 1/2 | 50 | 200 | |

Sleeve-All Anchor Product Data — Stainless Steel

| Size (in.) | Model No. | Head Style | Bolt Diameter – Threads per Inch | Max. Fixture Thickness (in.) | Quantity | |
|-------------|------------|------------|----------------------------------|------------------------------|----------|--------|
| | | | | | Box | Carton |
| 3/8 x 1 7/8 | SL37178HSS | Hex Head | 5/16-18 | 3/8 | 50 | 250 |
| 3/8 x 3 | SL37300HSS | | | 1 1/2 | 50 | 200 |
| 1/2 x 3 | SL50300HSS | | 3/8-16 | 3/4 | 25 | 100 |
| 1/2 x 4 | SL50400HSS | | | 1 3/4 | 25 | 100 |

Sleeve-All Anchor (with rod coupler) Product Data — Zinc-Plated Carbon Steel

| Size (in.) | Model No. | Accepts Rod Diameter (in.) | Wrench Size | Quantity | |
|-------------|-----------|----------------------------|-------------|----------|--------|
| | | | | Box | Carton |
| 3/8 x 1 7/8 | SL37178C | 3/8 | 1/2 | 50 | 200 |
| 1/2 x 2 1/4 | SL50214C | 1/2 | 5/8 | 25 | 100 |
| 5/8 x 2 1/4 | SL62214C | 5/8 | 3/4 | 20 | 80 |

Length Identification Head Marks on Sleeve-All Anchors (corresponds to length of anchor — inches)

| Mark | A | B | C | D | E | F | G | H | I | J | K | L | M | N | O | P | Q | R | S | T | U | V | W | X | Y | Z |
|-------------------------|-------|-------|-------|-------|-------|-------|-------|-------|-------|-------|-------|-------|-------|-------|-------|-------|-------|----|----|----|----|----|----|----|----|----|
| From | 1 1/2 | 2 | 2 1/2 | 3 | 3 1/2 | 4 | 4 1/2 | 5 | 5 1/2 | 6 | 6 1/2 | 7 | 7 1/2 | 8 | 8 1/2 | 9 | 9 1/2 | 10 | 11 | 12 | 13 | 14 | 15 | 16 | 17 | 18 |
| Up To But Not Including | 2 | 2 1/2 | 3 | 3 1/2 | 4 | 4 1/2 | 5 | 5 1/2 | 6 | 6 1/2 | 7 | 7 1/2 | 8 | 8 1/2 | 9 | 9 1/2 | 10 | 11 | 12 | 13 | 14 | 15 | 16 | 17 | 18 | 19 |

C-A-2023 © 2023 SIMPSON STRONG-TIE COMPANY, INC.

Mechanical Anchors

Sleeve-All® Design Information — Concrete and Masonry

Mechanical Anchors

Allowable Tension and Shear Loads for Sleeve-All in Normal-Weight Concrete



| Size in. (mm) | Embed. Depth in. (mm) | Critical Edge Dist. in. (mm) | Critical Spacing Dist. in. (mm) | Tension Load | | | | | | Shear Load | | | Install. Torque ft.-lb. (N-m) |
|---------------|-----------------------|------------------------------|---------------------------------|--|--------------------|-----------------|--|--------------------|-----------------|--|--------------------|-----------------|-------------------------------|
| | | | | f _c ≥ 2,000 psi (13.8 MPa) Concrete | | | f _c ≥ 4,000 psi (27.6 MPa) Concrete | | | f _c ≥ 2,000 psi (13.8 MPa) Concrete | | | |
| | | | | Ultimate lb. (kN) | Std. Dev. lb. (kN) | Allow. lb. (kN) | Ultimate lb. (kN) | Std. Dev. lb. (kN) | Allow. lb. (kN) | Ultimate lb. (kN) | Std. Dev. lb. (kN) | Allow. lb. (kN) | |
| 1/4 (6.4) | 1 1/8 (29) | 2 1/2 (64) | 4 1/2 (114) | 880 (3.9) | 94 (0.4) | 220 (1.0) | 1,320 (5.9) | 189 (0.8) | 330 (1.5) | 1,440 (6.4) | 90 (0.4) | 360 (1.6) | 5 (7) |
| 5/16 (7.9) | 1 (25) | 3 1/8 (79) | 5 3/4 (146) | 930 (4.1) | 201 (0.9) | 230 (1.0) | 1,095 (4.9) | 118 (0.5) | 275 (1.2) | 1,480 (6.6) | 264 (1.2) | 370 (1.6) | 8 (11) |
| | 1 7/16 (37) | 3 1/8 (79) | 5 3/4 (146) | 1,120 (5.0) | 113 (0.5) | 280 (1.2) | 1,320 (5.9) | 350 (1.6) | 330 (1.5) | 2,160 (9.6) | 113 (0.5) | 540 (2.4) | 8 (11) |
| 3/8 (9.5) | 1 1/2 (38) | 3 3/4 (95) | 6 (152) | 1,600 (7.1) | 294 (1.3) | 400 (1.8) | 2,680 (11.9) | 450 (2.0) | 670 (3.0) | 3,080 (13.7) | 223 (1.0) | 770 (3.4) | 15 (20) |
| 1/2 (12.7) | 1 3/4 (45) | 5 (127) | 9 (229) | 2,900 (12.9) | 369 (1.6) | 725 (3.2) | 3,480 (15.5) | 529 (2.4) | 870 (3.9) | 4,250 (18.9) | 659 (2.9) | 1,060 (4.7) | 25 (34) |
| | 2 1/4 (57) | 5 (127) | 9 (229) | 3,160 (14.1) | 254 (1.1) | 790 (3.5) | 4,760 (21.2) | 485 (2.2) | 1,190 (5.3) | 5,000 (22.2) | 473 (2.1) | 1,250 (5.6) | 25 (34) |
| 5/8 (15.9) | 1 3/4 (45) | 6 1/4 (159) | 11 (279) | 3,200 (14.2) | 588 (2.6) | 800 (3.6) | 3,825 (17.0) | 243 (1.1) | 955 (4.2) | 4,625 (20.6) | 747 (3.3) | 1,155 (5.1) | 50 (68) |
| | 2 3/4 (70) | 6 1/4 (159) | 11 (279) | 4,200 (18.7) | 681 (3.0) | 1,050 (4.7) | 6,160 (27.4) | 1,772 (7.9) | 1,540 (6.9) | 8,520 (37.9) | 713 (3.2) | 2,130 (9.5) | 50 (68) |
| 3/4 (19.1) | 2 (51) | 7 1/2 (191) | 13 1/2 (343) | 3,200 (14.2) | 588 (2.6) | 800 (3.6) | 4,465 (19.9) | 1,017 (4.5) | 1,115 (5.0) | 5,080 (22.6) | 771 (3.4) | 1,270 (5.6) | 90 (122) |
| | 3 3/8 (86) | 7 1/2 (191) | 13 1/2 (343) | 6,400 (28.5) | 665 (3.0) | 1,600 (7.1) | 9,520 (42.3) | 674 (3.0) | 2,380 (10.6) | 10,040 (44.7) | 955 (4.2) | 2,510 (11.2) | 90 (122) |

1. The tabulated allowable loads are based on a safety factor of 4.0.
2. Allowable loads may not be increased for short-term loading due to wind or seismic forces.
3. Refer to allowable load-adjustment factors for spacing and edge distance on p. 122.
4. Drill bit diameter used in base material corresponds to nominal anchor diameter.
5. Allowable tension loads may be linearly interpolated between concrete strengths listed.
6. The minimum concrete thickness is 1 1/2 times the embedment depth.

Allowable Tension and Shear Loads for 3/8" Sleeve-All in Grout-Filled CMU (Anchor Installed in Horizontal Mortar Joint or Face Shell)



| Size in. (mm) | Embed. Depth in. (mm) | Min. Edge Dist. in. (mm) | Min. End Dist. in. (mm) | Min. Spacing in. (mm) | Tension Load | | Shear Load | | Install. Torque ft.-lb. (N-m) |
|---------------|-----------------------|--------------------------|-------------------------|-----------------------|-------------------|-----------------|-------------------|-----------------|-------------------------------|
| | | | | | Ultimate lb. (kN) | Allow. lb. (kN) | Ultimate lb. (kN) | Allow. lb. (kN) | |
| 3/8 (9.5) | 1 1/2 (38) | 16 (406) | 16 (406) | 24 (610) | 2,000 (8.9) | 400 (1.8) | 2,300 (10.2) | 460 (2.0) | 15 (20) |

See footnotes on p. 121.

*See p. 14 for an explanation of the load table icons.

Sleeve-All® Design Information — Concrete and Masonry

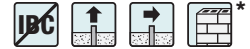

Allowable Tension and Shear Loads for Sleeve-All in Grout-Filled CMU

| Size in. (mm) | Embed. Depth in. (mm) | Min. Edge Dist. in. (mm) | Min. End Dist. in. (mm) | Min. Spacing in. (mm) | Tension Load | | Shear Load | | Install. Torque ft.-lb. (N-m) |
|--|-----------------------|--------------------------|-------------------------|-----------------------|-------------------|-----------------|-------------------|-----------------|-------------------------------|
| | | | | | Ultimate lb. (kN) | Allow. lb. (kN) | Ultimate lb. (kN) | Allow. lb. (kN) | |
| Anchor Installed in a Single Face Shell | | | | | | | | | |
| 3/8 (9.5) | 1 1/2 (38) | 12 (305) | 12 (305) | 24 (610) | 1,746 (7.8) | 350 (1.6) | 2,871 (12.8) | 575 (2.6) | 15 (20) |
| 1/2 (12.7) | 2 1/4 (57) | 12 (305) | 12 (305) | 24 (610) | 3,384 (15.1) | 675 (3.0) | 5,670 (25.2) | 1,135 (5.0) | 25 (34) |
| 5/8 (15.9) | 2 3/4 (70) | 12 (305) | 12 (305) | 24 (610) | 3,970 (17.7) | 795 (3.5) | 8,171 (36.3) | 1,635 (7.3) | 50 (68) |
| 3/4 (19.1) | 3 3/8 (86) | 12 (305) | 12 (305) | 24 (610) | 6,395 (28.4) | 1,280 (5.7) | 12,386 (55.1) | 2,475 (11.0) | 90 (122) |
| Anchor Installed in Mortar "T" Joint | | | | | | | | | |
| 3/8 (9.5) | 1 1/2 (38) | 8 (203) | 8 (203) | 24 (610) | 1,927 (8.6) | 385 (1.7) | 3,436 (15.3) | 685 (3.0) | 15 (20) |
| 1/2 (12.7) | 2 1/4 (57) | 8 (203) | 8 (203) | 24 (610) | 3,849 (17.1) | 770 (3.4) | 5,856 (26.0) | 1,170 (5.2) | 25 (34) |
| 5/8 (15.9) | 2 3/4 (70) | 8 (203) | 8 (203) | 24 (610) | 4,625 (20.6) | 925 (4.1) | 7,040 (31.3) | 1,410 (6.3) | 50 (68) |
| 3/4 (19.1) | 3 3/8 (86) | 8 (203) | 8 (203) | 24 (610) | 5,483 (24.4) | 1,095 (4.9) | 7,869 (35.0) | 1,575 (7.0) | 90 (122) |

- The tabulated allowable loads are based on a safety factor of 5.0.
- Listed loads may be applied to installations through a face shell with the following placement guidelines:
 - Minimum 3" from vertical mortar joint.
 - Minimum 1" from vertical cell centerline.
- Values for 6"- and 8"-wide concrete masonry units (CMU) with a minimum specified compressive strength of masonry, f_m , at 28 days is 1,500 psi.
- Embedment depth is measured from the outside face of the concrete masonry unit.
- Drill bit diameter used in base material corresponds to nominal anchor diameter.

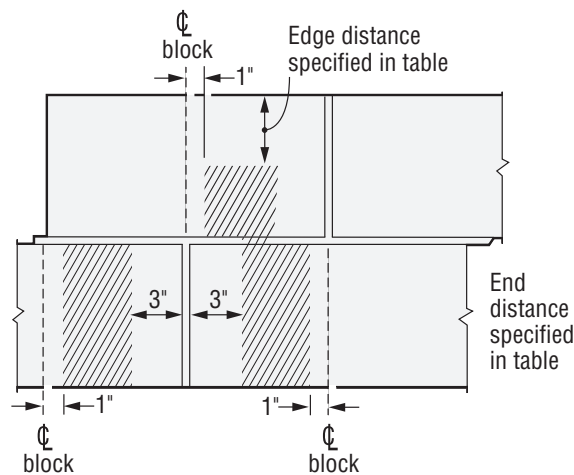

Face Shell Installation
Allowable anchor placement in grout-filled CMU shown by shaded areas.

*See p. 14 for an explanation of the load table icons.

Sleeve-All® Design Information — Concrete

Allowable Load-Adjustment Factors for Sleeve-All Anchors in Normal-Weight Concrete: Edge Distance and Spacing, Tension and Shear Loads

How to use these charts:

- The following tables are for reduced edge distance and spacing.
- Locate the anchor size to be used for either a tension and/or shear load application.
- Locate the edge distance (c_{act}) or spacing (s_{act}) at which the anchor is to be installed.
- The load adjustment factor (f_c or f_s) is the intersection of the row and column.
- Multiply the allowable load by the applicable load adjustment factor.
- Reduction factors for multiple edges or spacing are multiplied together.

Edge Distance Tension (f_c)

| Edge Dist. c_{act} (in.) | Size | 1/4 | 5/16 | 3/8 | 1/2 | 5/8 | 3/4 |
|----------------------------|------------|-------|--------|-------|-------|-------|-------|
| | c_{cr} | 2 1/2 | 3 1/8 | 3 3/4 | 5 | 6 1/4 | 7 1/2 |
| | c_{min} | 1 1/4 | 1 9/16 | 1 7/8 | 2 1/2 | 3 1/8 | 3 3/4 |
| | f_{cmin} | 0.60 | 0.60 | 0.60 | 0.60 | 0.60 | 0.60 |
| 1 1/4 | | 0.60 | | | | | |
| 1 1/2 | | 0.68 | | | | | |
| 1 9/16 | | 0.70 | 0.60 | | | | |
| 1 7/8 | | 0.80 | 0.68 | 0.60 | | | |
| 2 | | 0.84 | 0.71 | 0.63 | | | |
| 2 1/2 | | 1.00 | 0.84 | 0.73 | 0.60 | | |
| 3 | | | 0.97 | 0.84 | 0.68 | | |
| 3 1/8 | | | 1.00 | 0.87 | 0.70 | 0.60 | |
| 3 1/2 | | | | 0.95 | 0.76 | 0.65 | |
| 3 3/4 | | | | 1.00 | 0.80 | 0.68 | 0.60 |
| 4 | | | | | 0.84 | 0.71 | 0.63 |
| 4 1/2 | | | | | 0.92 | 0.78 | 0.68 |
| 5 | | | | | 1.00 | 0.84 | 0.73 |
| 5 1/2 | | | | | | 0.90 | 0.79 |
| 6 | | | | | | 0.97 | 0.84 |
| 6 1/4 | | | | | | 1.00 | 0.87 |
| 6 1/2 | | | | | | | 0.89 |
| 7 | | | | | | | 0.95 |
| 7 1/2 | | | | | | | 1.00 |

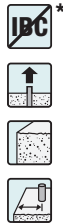

Spacing Tension and Shear (f_s)

| s_{act} (in.) | Size | 1/4 | 5/16 | 3/8 | 1/2 | 5/8 | 3/4 |
|-----------------|------------|-------|-------|------|-------|-------|--------|
| | s_{cr} | 4 1/2 | 5 3/4 | 6 | 9 | 11 | 13 1/2 |
| | s_{min} | 2 1/4 | 2 7/8 | 3 | 4 1/2 | 5 1/2 | 6 3/4 |
| | f_{smin} | 0.50 | 0.50 | 0.50 | 0.50 | 0.50 | 0.50 |
| 2 1/4 | | 0.50 | | | | | |
| 2 1/2 | | 0.56 | | | | | |
| 2 7/8 | | 0.64 | 0.50 | | | | |
| 3 | | 0.67 | 0.52 | 0.50 | | | |
| 3 1/2 | | 0.78 | 0.61 | 0.58 | | | |
| 4 | | 0.89 | 0.70 | 0.67 | | | |
| 4 1/2 | | 1.00 | 0.78 | 0.75 | 0.50 | | |
| 5 | | | 0.87 | 0.83 | 0.56 | | |
| 5 1/2 | | | 0.96 | 0.92 | 0.61 | 0.50 | |
| 5 3/4 | | | 1.00 | 0.96 | 0.64 | 0.52 | |
| 6 | | | | 1.00 | 0.67 | 0.55 | |
| 6 1/2 | | | | | 0.72 | 0.59 | |
| 6 3/4 | | | | | 0.75 | 0.61 | 0.50 |
| 7 | | | | | 0.78 | 0.64 | 0.52 |
| 8 | | | | | 0.89 | 0.73 | 0.59 |
| 9 | | | | | 1.00 | 0.82 | 0.67 |
| 10 | | | | | | 0.91 | 0.74 |
| 11 | | | | | | 1.00 | 0.81 |
| 12 | | | | | | | 0.89 |
| 13 | | | | | | | 0.96 |
| 13 1/2 | | | | | | | 1.00 |



See footnotes below.

Edge Distance Shear (f_c)

| Edge Dist. c_{act} (in.) | Size | 1/4 | 5/16 | 3/8 | 1/2 | 5/8 | 3/4 |
|----------------------------|------------|-------|--------|-------|-------|-------|-------|
| | c_{cr} | 2 1/2 | 3 1/8 | 3 3/4 | 5 | 6 1/4 | 7 1/2 |
| | c_{min} | 1 1/4 | 1 9/16 | 1 7/8 | 2 1/2 | 3 1/8 | 3 3/4 |
| | f_{cmin} | 0.30 | 0.30 | 0.30 | 0.30 | 0.30 | 0.30 |
| 1 1/4 | | 0.30 | | | | | |
| 1 1/2 | | 0.44 | | | | | |
| 1 9/16 | | 0.48 | 0.30 | | | | |
| 1 7/8 | | 0.65 | 0.44 | 0.30 | | | |
| 2 | | 0.72 | 0.50 | 0.35 | | | |
| 2 1/2 | | 1.00 | 0.72 | 0.53 | 0.30 | | |
| 3 | | | 0.94 | 0.72 | 0.44 | | |
| 3 1/8 | | | 1.00 | 0.77 | 0.48 | 0.30 | |
| 3 1/2 | | | | 0.91 | 0.58 | 0.38 | |
| 3 3/4 | | | | 1.00 | 0.65 | 0.44 | 0.30 |
| 4 | | | | | 0.72 | 0.50 | 0.35 |
| 4 1/2 | | | | | 0.86 | 0.61 | 0.44 |
| 5 | | | | | 1.00 | 0.72 | 0.53 |
| 5 1/2 | | | | | | 0.83 | 0.63 |
| 6 | | | | | | 0.94 | 0.72 |
| 6 1/4 | | | | | | 1.00 | 0.77 |
| 6 1/2 | | | | | | | 0.81 |
| 7 | | | | | | | 0.91 |
| 7 1/2 | | | | | | | 1.00 |

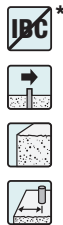

- E = Embedment depth (inches).
- s_{act} = actual spacing distance at which anchors are installed (inches).
- s_{cr} = critical spacing distance for 100% load (inches).
- s_{min} = minimum spacing distance for reduced load (inches).
- f_s = adjustment factor for allowable load at actual spacing distance.
- f_{scr} = adjustment factor for allowable load at critical spacing distance. f_{scr} is always = 1.00.
- f_{smin} = adjustment factor for allowable load at minimum spacing distance.
- $f_s = f_{smin} + [(1 - f_{smin})(s_{act} - s_{min}) / (s_{cr} - s_{min})]$.

- c_{act} = actual edge distance at which anchor is installed (inches).
- c_{cr} = critical edge distance for 100% load (inches).
- c_{min} = minimum edge distance for reduced load (inches).
- f_c = adjustment factor for allowable load at actual edge distance.
- f_{ccr} = adjustment factor for allowable load at critical edge distance. f_{ccr} is always = 1.00.
- f_{cmin} = adjustment factor for allowable load at minimum edge distance.
- $f_c = f_{cmin} + [(1 - f_{cmin})(c_{act} - c_{min}) / (c_{cr} - c_{min})]$.

*See p. 14 for an explanation of the load table icons.