

SBR/DBR Spacer Bracers



This product is preferable to similar connectors because of a) easier installation, b) higher loads, c) lower installed cost, or a combination of these features.

Simpson Strong-Tie introduces the SBR and DBR spacer bracers for cold-formed steel construction. These spacer bracers reduce the installed cost of cold-formed steel stud walls by enabling faster stud layout while minimizing the need for bridging clips.

The DBR is used for interior walls to eliminate stud bow and allow for quicker drywall attachment, while the SBR is designed for structural exterior walls. Both products provide bracing along the length of the stud, and for head-of-wall slip conditions. The SBR and DBR also come with prepunched slots that eliminate the need to use bridging clips with on-module studs.

The SBR and DBR spacer bracers come with bracing load data based on assembly testing, thus mitigating risk for designers and maximizing confidence in design specs. In fact, the SBR and DBR are the only spacer bracers on the market with tabulated design values based on assembly tests.

Features:

- SBR and DBR have patent-pending precision-engineered prepunched slots strategically located to enable 12", 16" and 24" on-center stud spacing and can be used to space the studs without having to mark the top track for layout
- The SBR will accommodate 3/8" up to 8" studs in thicknesses of 33 mil (20 ga.) through 68 mil (14 ga.)
- The DBR will accommodate 2 1/2", 3 3/8" and 6" studs in thicknesses of 15 mil (25 ga. EQ) through 33 mil (20 ga.)
- Prepunched holes in the SBR provide rapid screw installation when spacer-bracer splices are needed for axial load-bearing studs
- In off-layout or end-of run conditions, the hat-section profiles enable clip attachments to the stud with Simpson Strong-Tie® LSSC or RCA connectors

Installation:

- Spacer bracers are fed through the stud knockout at a 90° angle until studs align with spacer-bracer slots. With the slots engaging the stud web, the spacer-bracer is then rotated back to the flat position so that the slotted flanges are on the bottom.
- For off-layout or end-of-run studs where a spacer-bracer slot does not engage a stud, manually snip the spacer-bracer flanges with a 1/2"-deep slot and secure the spacer bracer to the stud with Simpson Strong-Tie LSSC or RCA connectors. Use all specified fasteners.
- Wear gloves while handling and installing spacer bracers.

Material: SBR/43 — 43 mil (40 ksi);
DBR/30 — 27 mil (33 ksi)

Finish: Galvanized (G90)

Codes: See p. 13 for Code Reference Key Chart

Ordering Information:

SBR/43-R680 (Pallet 680) SBR/43-R20 (Box of 20)
DBR/30-R680 (Pallet 680) DBR/30-R20 (Box of 20)

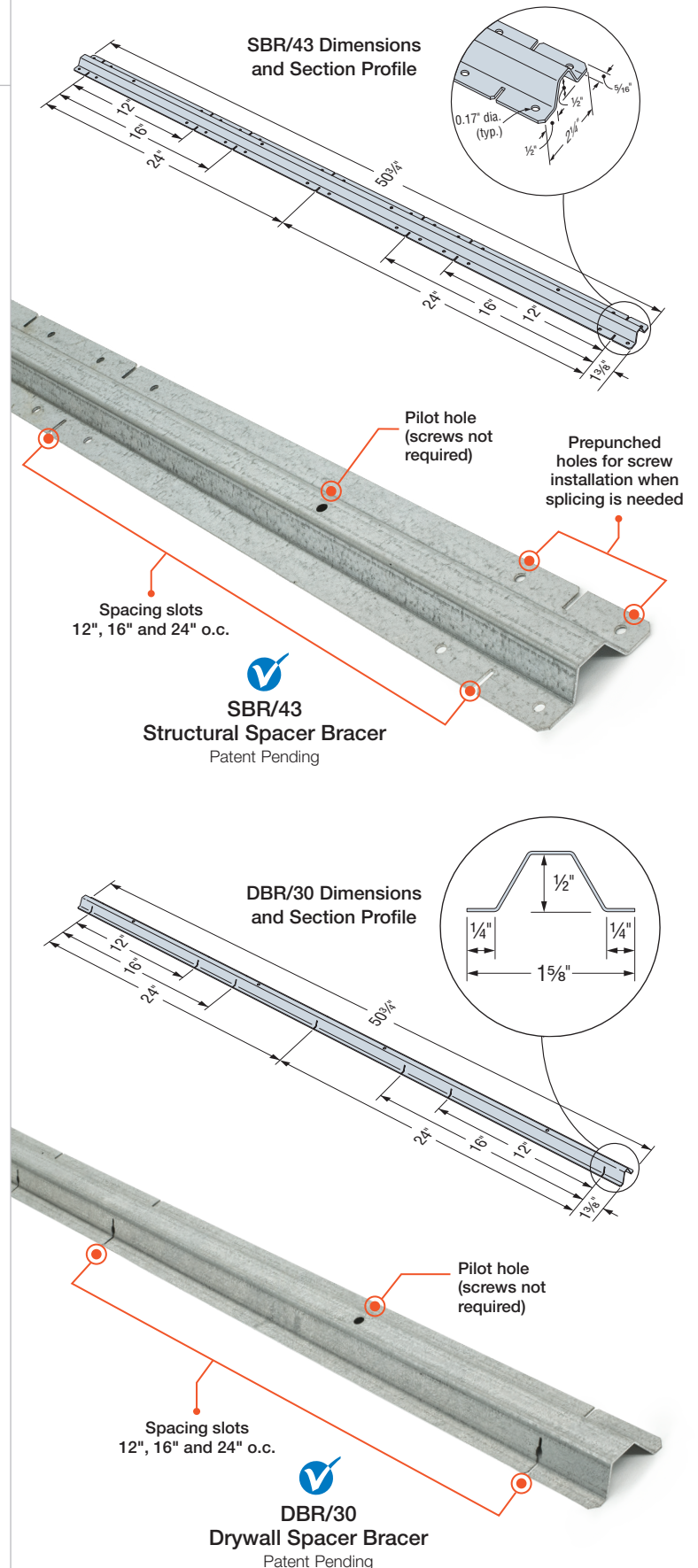

SBR/DBR Spacer Bracers

SBR and DBR Spacer Bracer — Connection Strength and Stiffness

Model No.	Stud Depth (in.)	Stud Thickness mil (ga.)	Allowable Torsional Moment (in./lb.)	Allowable Brace Strength (lb.)	Brace Stiffness (lb./in.)	Code Ref.
SBR/43	3½	33 (20)	235	390	845	—
		43 (18)	310	435	1,390	
		54 (16)	400	435	1,390	
		68 (14)	400	435	1,390	
	6	33 (20)	215	160	495	
		43 (18)	310	330	765	
		54 (16)	365	450	840	
		68 (14)	365	450	840	
	8	33 (20)	200	—	—	
		43 (18)	310	—	—	
		54 (16)	335	—	—	
		68 (14)	335	—	—	
DBR/30	2½	15 (25 EQ)	55	—	—	
		18 (25)	55	—	—	
		19 (20 EQ)	60	—	—	
		30 (20 DW)	85	—	—	
		33 (20 STR)	90	—	—	
	6	15 (25 EQ)	55	—	—	
		18 (25)	55	—	—	
		19 (20 EQ)	60	—	—	
		30 (20 DW)	85	—	—	
		33 (20 STR)	90	—	—	

1. Allowable loads are for use when utilizing the traditional Allowable Stress Design methodology. For LRFD loads multiply the ASD tabulated values by 1.6.
2. Tabulated Allowable Brace Strengths are based on ultimate test load divided by a safety factor. Serviceability limit is not considered, as brace stiffness requirements are given in section C2.3 of AISI S100-16.
3. Tabulated Brace Stiffness values apply to both ASD and LRFD designs.
4. Allowable loads consider bridging connection only. It is the responsibility of the designer to verify the strength and serviceability of the framing members.
5. EQ — equivalent, DW — drywall, STR — structural.

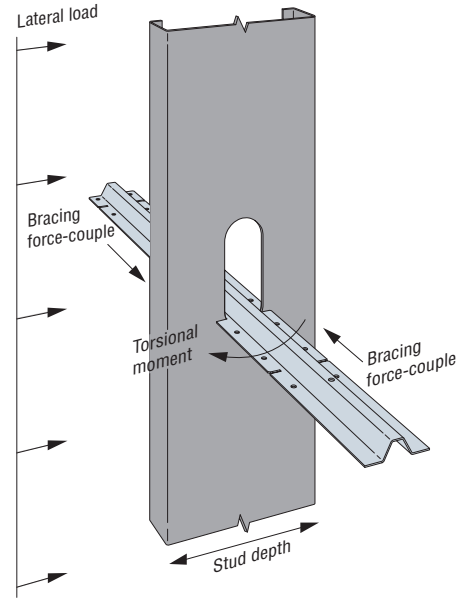

Laterally Loaded C-Stud with SBR Spacer Bracer
(DBR spacer bracer similar)

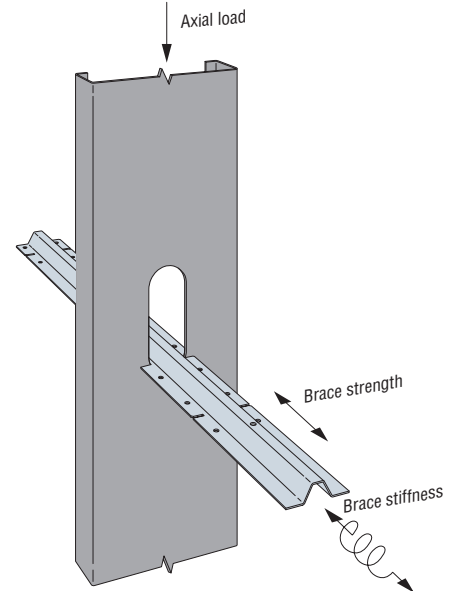

Axially Loaded C-Stud with SBR Spacer Bracer

SBR/DBR Spacer Bracers

SBR and DBR Gross Properties

Model No.	Design Thickness (in.)	F _y (ksi)	Area ² (in.)	I _x ⁴ (in.)	S _x ³ (in.)	R _x (in.)	I _y ⁴ (in.)	S _y ³ (in.)	R _y (in.)	Torsional Properties					
										Jx1,000 ⁴ (in.)	C _w ⁶ (in.)	Y ₀ (in.)	m (in.)	R ₀ (in.)	β
SBR/43	0.0468	40	0.126	0.0047	0.1458	0.1936	0.0436	0.0400	0.5891	0.0916	5.56E-04	0.283	0.017	0.681	0.828
DBR/30	0.0289	33	0.060	0.0023	0.0082	0.1936	0.0109	0.0141	0.4259	0.0167	7.05E-05	0.346	0.087	0.582	0.647

SBR and DBR Net Properties

Model No.	Area ² (in.)	I _x ⁴ (in.)	S _x ³ (in.)	R _x (in.)	I _y ⁴ (in.)	S _y ³ (in.)	R _y (in.)	Torsional Properties					
								Jx1,000 ⁴ (in.)	C _w ⁶ (in.)	Y ₀ (in.)	m (in.)	R ₀ (in.)	β
SBR/43	0.085	0.0028	0.0097	0.1816	0.0120	0.0184	0.3765	0.0617	3.43E-05	0.355	0.141	0.548	0.581
DBR/30	0.022	0.0001	0.0004	0.0479	0.0008	0.0027	0.1944	0.0061	1.09E-06	0.086	0.051	0.218	0.844

SBR and DBR Allowable Member Strengths

Model No.	M _a (F _y) (in.-lb.)	M _a (12" o.c.) (in.-lb.)	M _a (16" o.c.) (in.-lb.)	M _a (24" o.c.) (in.-lb.)	P _a (12" o.c.) (lb.)	P _a (16" o.c.) (lb.)	P _a (24" o.c.) (lb.)
SBR/43	369	369	369	360	945	904	618
DBR/30	44	40	38	32	—	—	—

1. Net section properties are based a section that excludes all material that is interrupted by the slots.
2. Member strengths are based on DSM Analysis (non-prequalified section, $\Omega = 2.0$).
3. C_b = 1.67 has been applied to M_a to account for a triangular moment diagram with zero end moment.

SBR/DBR Spacer Bracers

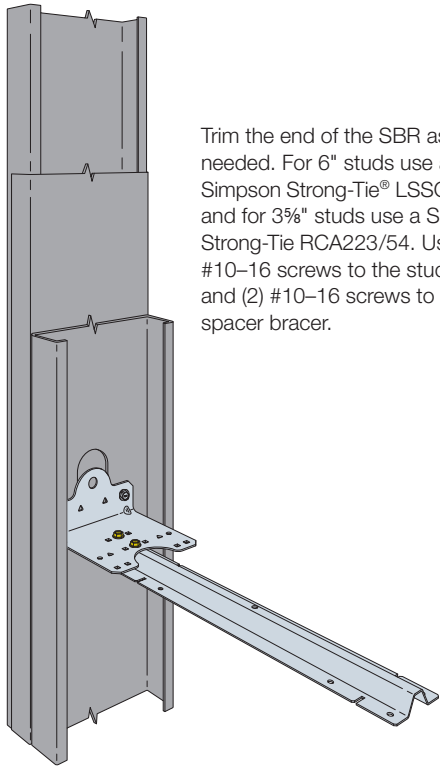

Trim the end of the SBR as needed. For 6" studs use a Simpson Strong-Tie® LSSC4.25 and for 3½" studs use a Simpson Strong-Tie RCA223/54. Use (2) #10–16 screws to the stud web, and (2) #10–16 screws to the spacer bracer.

SBR End-of-Run for 6" Studs with LSSC4.25
(3½" studs with RCA 223/54 similar)

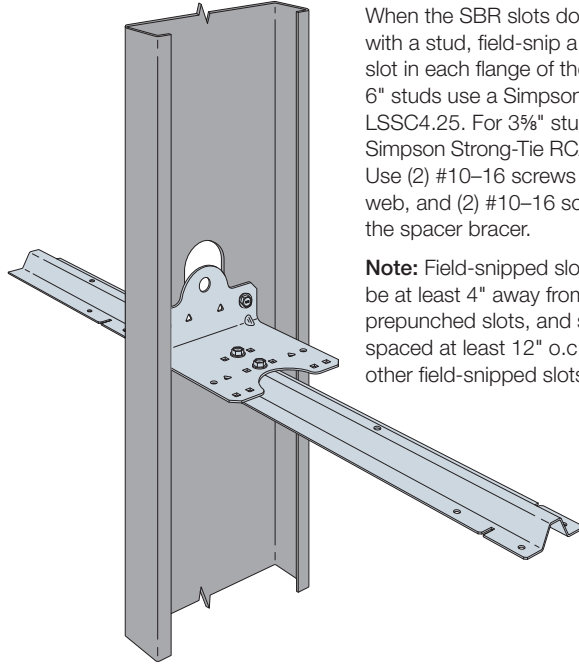

When the SBR slots do not line up with a stud, field-snip a ½"-deep slot in each flange of the SBR. For 6" studs use a Simpson Strong-Tie LSSC4.25. For 3½" studs use a Simpson Strong-Tie RCA223/54. Use (2) #10–16 screws to the stud web, and (2) #10–16 screws to the spacer bracer.

Note: Field-snipped slots shall be at least 4" away from other prepunched slots, and shall be spaced at least 12" o.c. from other field-snipped slots.

SBR Off-Module for 6" Studs with LSSC4.25
(3½" studs with RCA 223/54 similar)

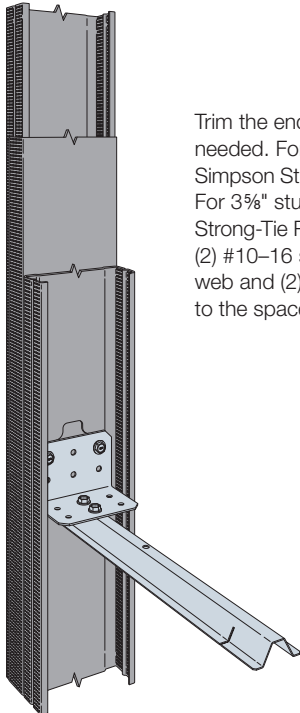

Trim the end of the DBR as needed. For 6" studs use a Simpson Strong-Tie LSSC4.25. For 3½" studs use a Simpson Strong-Tie RCA223/54. Use (2) #10–16 screws to the stud web and (2) #10–16 screws to the spacer bracer.

DBR End-of-Run for 3½" Studs with RCA223/54
(6" studs with LSSC4.25 similar)

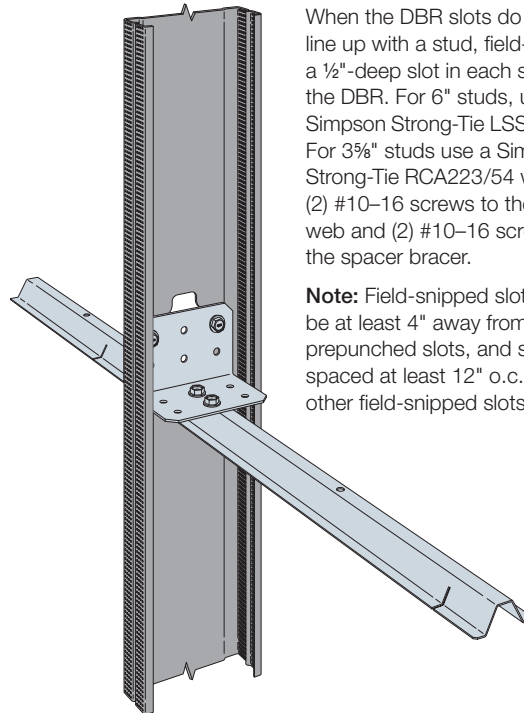

When the DBR slots do not line up with a stud, field-snip a ½"-deep slot in each side of the DBR. For 6" studs, use a Simpson Strong-Tie LSSC4.25. For 3½" studs use a Simpson Strong-Tie RCA223/54 with (2) #10–16 screws to the stud web and (2) #10–16 screws to the spacer bracer.

Note: Field-snipped slots shall be at least 4" away from other prepunched slots, and shall be spaced at least 12" o.c. from other field-snipped slots.

DBR Off-Module for 3½" Studs with RCA223/54
(6" studs with LSSC4.25 similar)

SBR/DBR Spacer Bracers

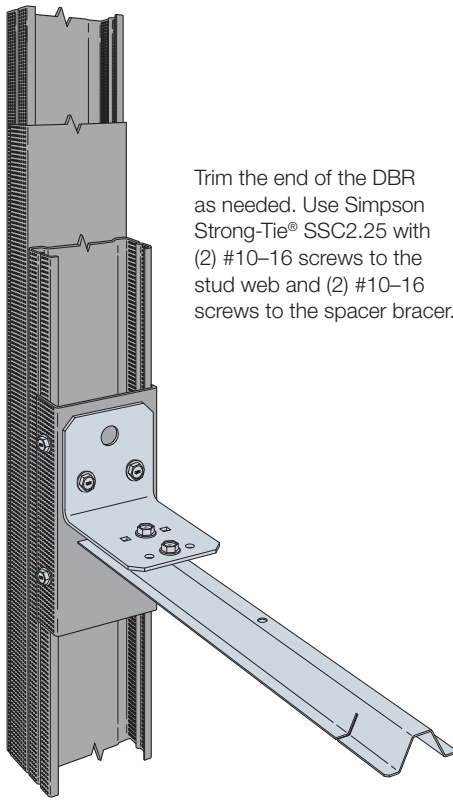

Trim the end of the DBR as needed. Use Simpson Strong-Tie® SSC2.25 with (2) #10-16 screws to the stud web and (2) #10-16 screws to the spacer bracer.

DBR End-of-Run for 2.5" Studs with SSC2.25

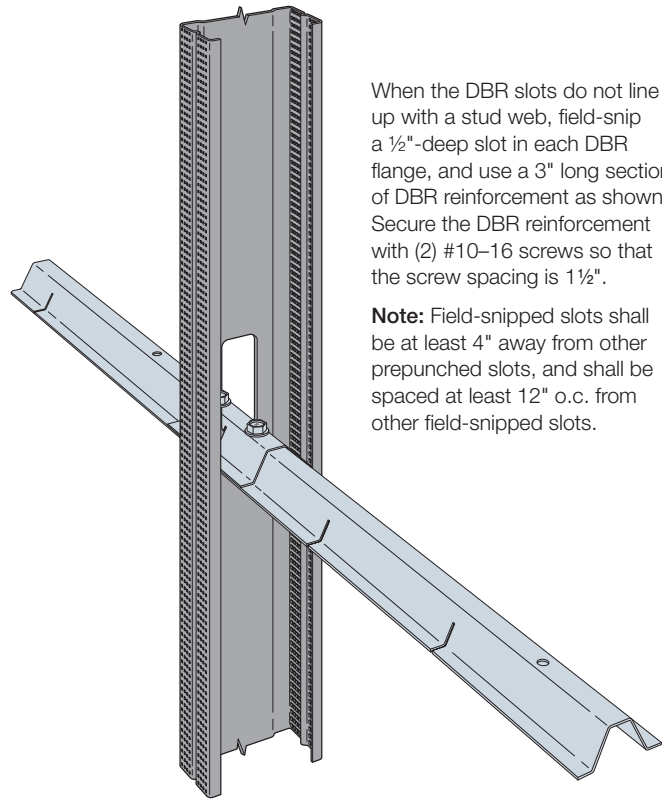

When the DBR slots do not line up with a stud web, field-snip a 1/2"-deep slot in each DBR flange, and use a 3" long section of DBR reinforcement as shown. Secure the DBR reinforcement with (2) #10-16 screws so that the screw spacing is 1 1/2".

Note: Field-snipped slots shall be at least 4" away from other prepunched slots, and shall be spaced at least 12" o.c. from other field-snipped slots.

DBR Off-Module for 2 1/2" Studs with DBR Reinforcement
(DBR and SBR with 3 5/8" studs and 6" studs similar)

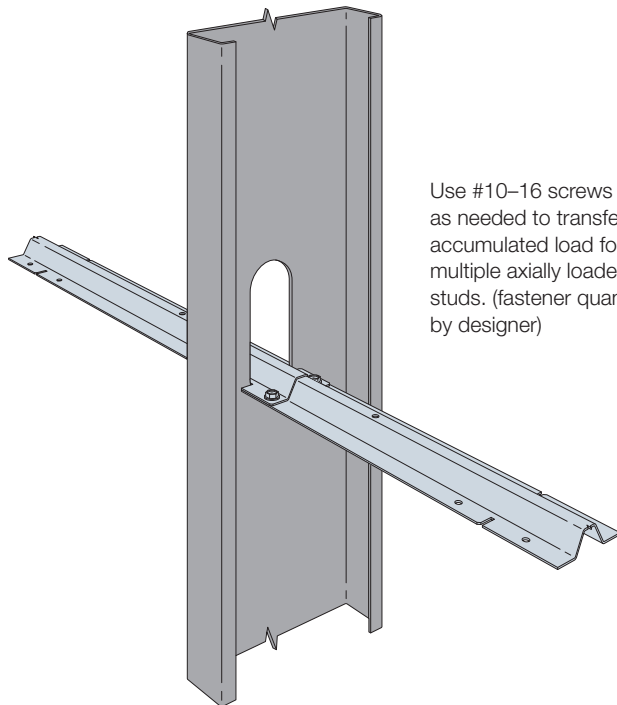

Use #10-16 screws as needed to transfer accumulated load for multiple axially loaded studs. (fastener quantity by designer)

Typical SBR Splice for Axially Loaded Studs

SBR/DBR Spacer Bracers

Bridging, Bracing and Backing

SBR/43 Maximum Bridging Distance (ft.)

Stud Spacing (in.)	Stud Section	Stud Thickness mil (ga.)	Lateral Stud Pressure (psf)									
			5	10	15	20	25	30	35	40	45	50
12	362S162	33 (20)	8	8	8	8	7	6	5	4	4	—
		43 (18)	8	8	8	8	8	8	7	6	5	5
		54 (16)	8	8	8	8	8	8	8	7	7	6
		68 (14)	8	8	8	8	8	8	8	8	7	6
	362S200	33 (20)	8	8	8	7	6	5	4	—	—	—
		43 (18)	8	8	8	8	8	6	5	5	4	4
		54 (16)	8	8	8	8	8	8	6	6	5	4
		68 (14)	8	8	8	8	8	8	6	6	5	4
	600S162	33 (20)	8	8	8	8	8	7	6	5	4	4
		43 (18)	8	8	8	8	8	8	8	7	6	6
		54 (16)	8	8	8	8	8	8	8	8	8	7
		68 (14)	8	8	8	8	8	8	8	8	8	7
600S200	33 (20)	8	8	8	7	6	5	4	—	—	—	
	43 (18)	8	8	8	8	8	7	6	5	5	4	
	54 (16)	8	8	8	8	8	8	7	6	6	5	
	68 (14)	8	8	8	8	8	8	7	6	6	5	
16	362S162	33 (20)	8	8	8	7	5	4	4	—	—	—
		43 (18)	8	8	8	8	7	6	5	4	4	—
		54 (16)	8	8	8	8	8	7	6	5	5	4
		68 (14)	8	8	8	8	8	8	6	6	5	4
	362S200	33 (20)	8	8	7	5	4	—	—	—	—	—
		43 (18)	8	8	8	7	6	5	4	—	—	—
		54 (16)	8	8	8	8	7	6	5	4	4	—
		68 (14)	8	8	8	8	7	6	5	4	4	—
	600S162	33 (20)	8	8	8	7	6	5	4	—	—	—
		43 (18)	8	8	8	8	8	7	6	5	5	4
		54 (16)	8	8	8	8	8	8	7	6	6	5
		68 (14)	8	8	8	8	8	8	7	6	6	5
600S200	33 (20)	8	8	7	5	4	—	—	—	—	—	
	43 (18)	8	8	8	8	6	5	4	4	—	—	
	54 (16)	8	8	8	8	8	6	5	5	4	4	
	68 (14)	8	8	8	8	8	6	5	5	4	4	
24	362S162	33 (20)	8	8	6	4	—	—	—	—	—	—
		43 (18)	8	8	8	6	5	4	—	—	—	—
		54 (16)	8	8	8	7	6	5	4	—	—	—
		68 (14)	8	8	8	7	6	5	4	—	—	—
	362S200	33 (20)	8	7	5	—	—	—	—	—	—	—
		43 (18)	8	8	6	5	4	—	—	—	—	—
		54 (16)	8	8	7	5	4	—	—	—	—	—
		68 (14)	8	8	7	5	4	—	—	—	—	—
	600S162	33 (20)	8	8	7	5	4	—	—	—	—	—
		43 (18)	8	8	8	7	6	5	4	—	—	—
		54 (16)	8	8	8	8	7	6	5	4	4	—
		68 (14)	8	8	8	8	7	6	5	4	4	—
600S200	33 (20)	8	7	5	—	—	—	—	—	—	—	
	43 (18)	8	8	7	5	4	—	—	—	—	—	
	54 (16)	8	8	8	6	5	4	—	—	—	—	
	68 (14)	8	8	8	6	5	4	—	—	—	—	

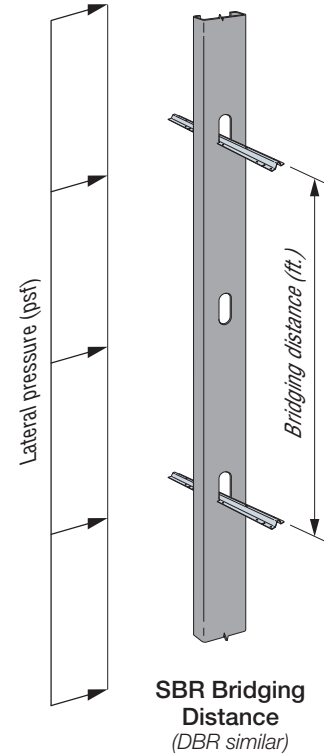

1. Tabulated solutions are for ASD lateral pressure. Contact Simpson Strong-Tie for LRFD solutions.
2. Lateral pressures shall be determined based on the load combinations of the applicable building code. For designs in accordance with the 2009 IBC and earlier, wind pressures are at the working stress level and may be used directly. For designs in accordance with the 2012, 2015, 2018 and 2021 IBC, wind pressures are at the strength level and must be multiplied by 0.6 for ASD load combinations.
3. Tabulated values are based on the minimum of the tested connection strength and the calculated SBR/DBR member strength. Studs must be checked separately for unbraced length.
4. For 8"-studs tabulated values, reference strongtie.com.

SBR/DBR Spacer Bracers

DBR/30 Maximum Bridging Distance (ft.)

Stud Spacing (in.)	Stud Section	Stud Thickness mil (ga.)	Lateral Stud Pressure (psf)	
			5	10
12	362S125	15 (25 EQ)	8	5
		18 (25)	8	5
		19 (20 EQ)	8	5
		30 (20 DW)	8	5
		33 (20 STR)	8	5
	600S125	15 (25 EQ)	8	6
		18 (25)	8	6
		19 (20 EQ)	8	6
		30 (20 DW)	8	6
		33 (20 STR)	8	6
16	362S125	15 (25 EQ)	7	—
		18 (25)	7	—
		19 (20 EQ)	7	—
		30 (20 DW)	7	—
		33 (20 STR)	7	—
	600S125	15 (25 EQ)	8	4
		18 (25)	8	4
		19 (20 EQ)	8	4
		30 (20 DW)	8	4
		33 (20 STR)	8	4
24	362S125	15 (25 EQ)	4	—
		18 (25)	4	—
		19 (20 EQ)	4	—
		30 (20 DW)	4	—
	600S125	33 (20 STR)	4	—
		15 (25 EQ)	4	—
		18 (25)	4	—
		19 (20 EQ)	4	—
		30 (20 DW)	5	—
		33 (20 STR)	5	—

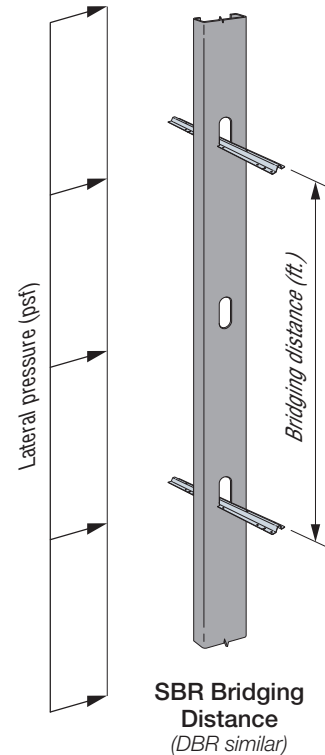

1. Tabulated solutions are for ASD lateral pressure. Contact Simpson Strong-Tie for LRFD solutions.
2. Lateral pressures shall be determined based on the load combinations of the applicable building code. For designs in accordance with the 2009 IBC and earlier, wind pressures are at the working stress level and may be used directly. For designs in accordance with the 2012 and later IBC, wind pressures are at the strength level and must be multiplied by 0.6 for ASD load combinations.
3. Tabulated values are based on the minimum of the tested connection strength and the calculated SBR/DBR member strength. Studs must be checked separately for unbraced length.