

H2
Headset Helmet Intercom

User Manual

Thank you for choosing MOMAN product. Please read this manual carefully before use and follow all instructions mentioned herein.

Caring For Your MOMAN Product

- Please keep the product in a dry, clean, dust-free environment.
- Keep corrosive chemicals, liquids and heat source away from the product to prevent mechanics damage.
- Use only a soft and dry cloth for cleaning the product.
- Malfunction may be caused by dropping, impact of external force.
- Do not attempt to disassemble the product. Doing so voids warranty.
- Please have the product checked or repaired by authorized technicians if any malfunctions happened.
- Failure to follow all the instructions may result in mechanics damage.
- Warranty does not apply to human errors.

Package List

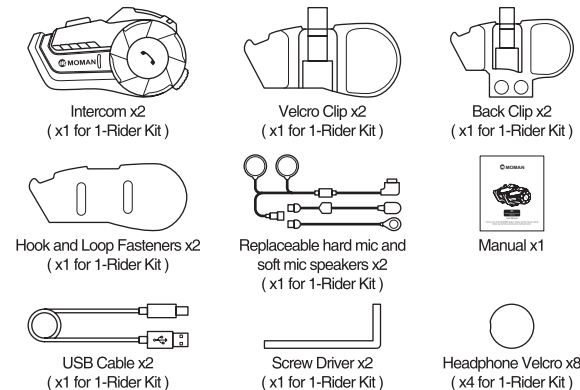

Product Introduction

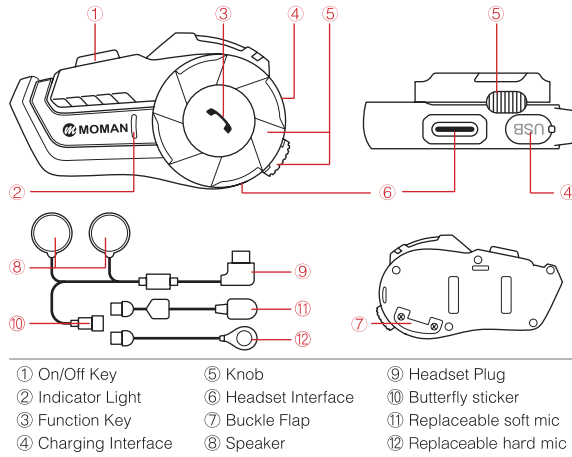

Important Notice:

Before installing the headsets, follow the Quick Manual instructions to connect your phone and audition the sound and volume. If there is a large difference in sound effect and volume after installing it on the helmet, please adjust the position of the speaker in the helmet.

Operation

1. Power On/Off

ON: Press the ON/OFF key for 2 seconds.
OFF: Long Press the ON/OFF key for 5 seconds.



2. Phone Control

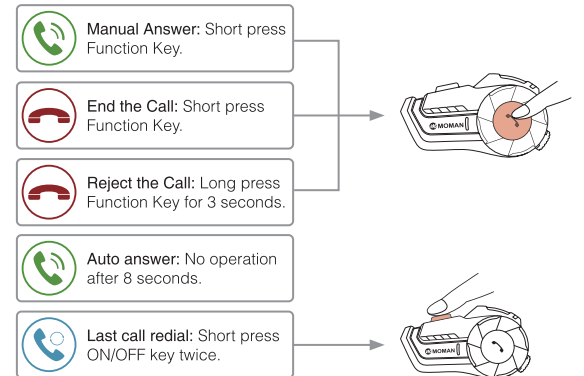

3. Music Control

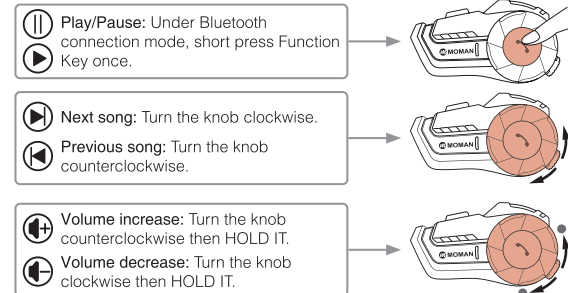

※ There is voice alarm for too high and too low volume.

4. FM Radio

① ON: Under Standby mode, quickly press function key twice.

② OFF: Quickly press function key twice.

③ Select channels: Quickly rotate and release the knob to select and adjust.

Notes:

If the signal is weak indoor, you could try to turn on the FM radio near window or in the open area.

When FM radio is turned on and there is a phone calling, the machine will cut off FM radio automatically and connect to the mobile phone. It gets back to the FM radio when the call ends.

5. Language Change

Power on, press the ON/OFF key and rotate the knob at the same time.

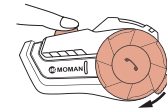

6. Pairing and Disconnection

6.1 With Mobile Phone:

- ① Enter Standby mode: Power on, blue light flashes twice, then red & blue light flash alternatively.
- ② Pairing: Turn on the bluetooth function, search "MOMAN H2" to connect.



Notes:

Automatic connection: If the Moman H2 has a pairing record with smartphone before, it will automatically connect to the mobile phone after power on. Please provided that Bluetooth is turned on.

6.2 Two Intercoms Pairing

- ① Enter Standby mode: Power on, blue light flashes twice, then red & blue light flash alternatively.
- ② Press the ON/OFF key of 1 intercom, the blue indicator light flashes quickly.



Notes:

Automatic connection: Once the intercoms are paired successfully, they will be paired automatically under standby mode after a few seconds.

6.3 Reconnect&Disconnect

- ① Reconnect: Press the Function Key for 2 seconds. Voice prompt: "Di".
- ② Disconnect: Press the Function Key for 2 seconds. Voice prompt: "Di".

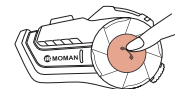

Notes:

Environment reason disconnection: Intercoms will be paired automatically within 5 minutes. Not connected after 5 minutes, you can short press Function Key once to connect manually.

7. Multi-Mode Switch

① Between Intercom and Musci/FM Radio:

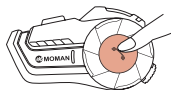

Voice prompt: "Di"

Exit Intercom mode and enter Music/ FM Radio mode

Under Intercom mode, press the Function Key for 2 seconds

② Between Intercom and Mobile Phone:

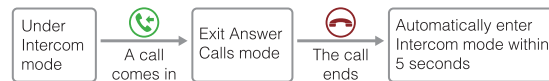

8. Function Priority

- Level 1: Mobile Phone
- Level 2: Intercom
- Level 3: Music/FM Radio

Installation

1. Method 1: Install with Back Clip

- ① Use the screwdriver to loosen the screws of the back clip so that it can open to a proper extent.
- ② Open the helmet liner, insert the clip into the right position on the left side of the helmet and tighten the screw.
- ③ Slide the intercom into the back clip slot to make sure it locks firmly.
- ④ Open the helmet liner (ear position), clean the EPS surface of the helmet, and stick a piece of horn Velcro on the left and right sides of the helmet.
- ⑤ Stick the speaker on the fixed Velcro surface and the speaker with short line should be installed close to the machine. Fix the microphone and arrange the helmet lining and cable.
- ⑥ Insert the headset into the jack of the intercom and tie up the headset cable.

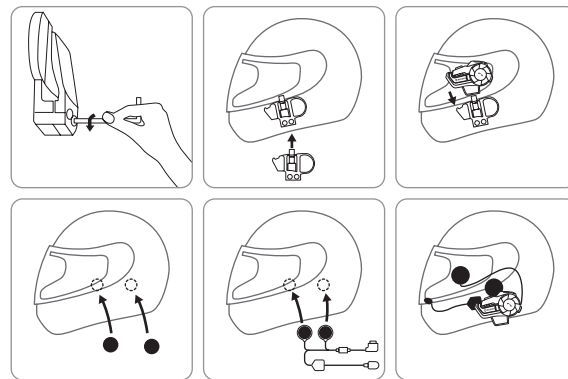

Method 2: Install with Velcro Clip

Separate the hook and loop fasteners. First stick the hook onto the Velcro clip; choose the right installation position on the helmet and stick the loop to the position. Install the intercom onto the Velcro clip.

The installation of speakers can refer to the description above.

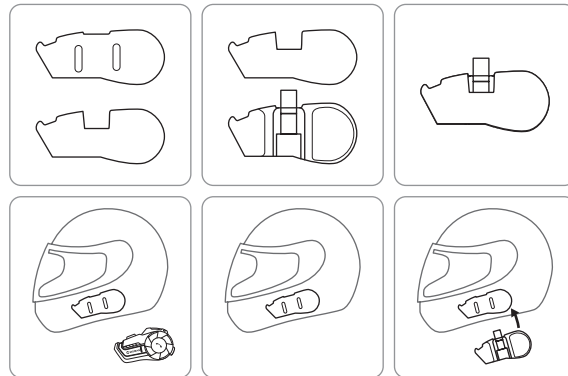

2. How to Remove the Intercom from Helmet

First unplug the headset, then press the fixed buckle in the middle of the back clip with one finger (push towards the side of the helmet), so that the back clip hook is detached from the intercom, and push the intercom upwards to let it slide out of the back clip smoothly to complete the disassembly.

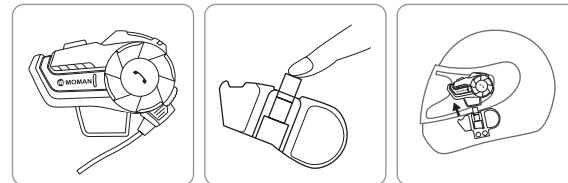

3. How to Fix the Headset Plug (If necessary)

Unscrew the screws on the back of intercom with screwdriver, open the buckle flap, plug in the headset plug and tighten the screws. If you need to plug out the headset, please open the buckle flap by unscrewing the screws.

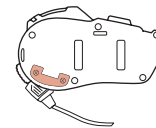

Installation

1. Before using the Bluetooth intercom, please use the attached charging cable to charge the intercom. The small type-C interface on the charging line is connected to the USB charging interface of the Bluetooth intercom, and the large USB connector on the charging cable is connected to the following charging interface for power supply:

- A. USB interface of computer;
- B. A mobile power supply with DC 5V output;
- C. A USB power adapter with DC 5V output.

2. When charging, the red LED is always on, and when fully charged, the red light goes out slowly. It takes up to 2.5 hours to fully charge the unit.

Specifications

Transmission Range	up to 1000m
Connection Distance with Mobile	20m
Bluetooth Version	5.0
Bluetooth Protocol	A2DP, AVRCP
Charging Port	Type-C
Standby Time	300H
Working Time	20H
Battery	900mAh
Charging Time	2H
Charging Voltage	5V
Speaker Diameter	40mm
Frequency Range	2.4GHz
Temperature Range	-20~50°C

Notes

1. If you do not use intercom for up to one month or more, please charge the intercom once every two months in order to protect the lithium battery;
2. The storage temperature of this product is -20 °C to 50 °C, and do not store in the environment with too high or low temperature, otherwise, the service life of the product will be affected;
3. Do not expose this product to fire to avoid explosion;
4. Only two screws on the back of intercom can be opened. Do not open other screws to the intercom to avoid short circuit of main board or battery damage.

Moman (UK) Limited

Unit 25 Basepoint Business Centre, Aviation Park, West Christchurch, United Kingdom BH23 6NX

www.momanx.com

@MomanGlobal

https://moman.co/youtube