

ROKINON®

SP

50MM F1.2 FOR CANON INSTRUCTION MANUAL



Thank you for purchasing the Rokinon SP 50mm F1.2 Full Frame lens. Its high performance optics and design have been optimized to meet the extreme capabilities of Canon state of the art cameras.

ADVANTAGES

- Provides exceedingly high quality stills and video with both Full Frame and APS-C (crop sensor) cameras.
- Its F1.2 aperture provides superior low light capability, faster shutter speeds and greater depth field control compared to its counterparts.
- Its advanced optical design of 11 precision glass elements, including 1 Aspherical and 1 High Refractive Index, combine for excellent control of distortion and aberrations with increased center to edge resolution.
- Its all metal construction with an ergonomically designed shape and grip deliver a luxurious look, excellent durability and comfortable use.

⚠ CAUTIONS

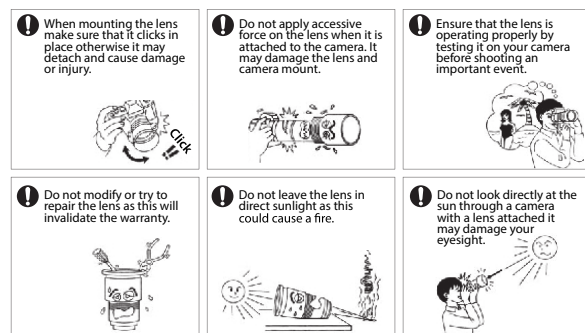

To maintain your safety and prevent damage to the lens, please fully familiarize yourself with the following:

- Do not look directly at the sun through the lens as it may seriously impair your vision.

- Do not apply excessive force when attaching the lens to the camera as it may cause damage to the lens or your camera.
- The lens is a precision optical product, so dropping or excessive impact may cause product failure.
- **Attach or detach the lens only while the camera is turned off.**
- Be careful not to touch or contaminate the contacts on the mount as it can adversely affect communication with the camera.
- Protect the lens from water, high humidity, excessive heat and cold.
- Always store the lens with the lens cap on in a dry and well ventilated location out of direct sunlight. Direct sunlight passing through the lens could become concentrated enough to cause a fire.
- Avoid subjecting the lens to drastic temperature changes such as moving from a very cold outdoors location to a warm indoors location. This can cause moisture in the air to condense inside or on the outside of the lens and lead to failure or mold production. Before taking the lens indoors from a cold outdoors location, put the lens in a plastic bag or sealed camera bag

ATTACHING THE LENS

- Remove the rear lens cap and the camera body cap.
- Align the red dot on the lens mount with the index mark (dot) on the lens mount of the camera.
- Do not press the lens release button on the camera when mounting the lens.
- Insert the lens into the camera mount and rotate it clockwise until it “clicks” and locks in place. **Do not insert the lens at an angle.**
- Remove the front lens cap when you are ready to shoot.

DETACHING THE LENS

- Attach the front lens cap.
- While holding down the lens release button on the camera body, rotate the lens counterclockwise until it stops and separate the lens from the body.
- Attach the rear lens cap.

FOCUSING

- Set the Focus Mode of your camera to “MF” (Manual Focus). Adjust the focus by rotating the focusing ring on the lens until the focus confirmation indicator in your viewfinder confirms focus or the subject looks the sharpest.
- Another focusing option is to use the magnifying feature of “Live View”. Utilizing the highest magnification available, adjust the focus by rotating the focusing ring until the image on your LCD screen looks the sharpest.

Please note: Check your camera’s instruction book as additional manual focusing focusing methods will vary depending on the camera model.

USING FILTERS

The Rokinon SP 50mm F1.2 is equipped with filter threads that can accept standard 86mm diameter filters. To maintain full performance please utilize only high quality optical glass filters.

Please note: Using more than one filter at a time may cause vignetting.

PARTS

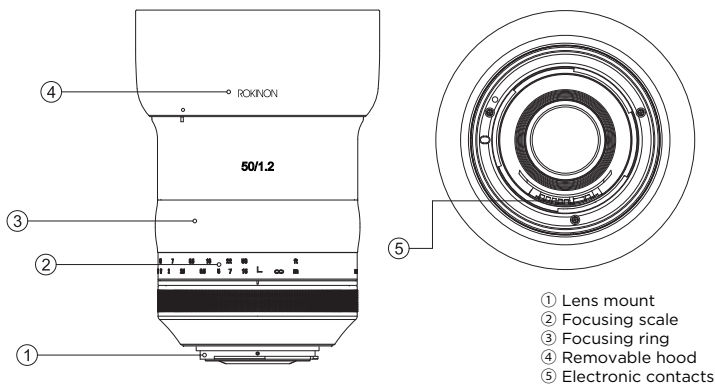

INCLUDED COMPONENTS

- Front lens cap
- Rear lens cap
- Removable lens hood
- Soft lens pouch
- Instruction manual
- Warranty

CLEANING

Please note: It is extremely important before cleaning to dust off the lens surface using a lens blower or a soft brush to remove any foreign particles or grit that could scratch the lens.

- Using a clean microfiber lens cloth, gently wipe the lens in a circular motion from the center outwards towards the edges of the glass.
- If stubborn spots remain, put only one or two small drops of ethanol or reputable lens cleaner on the microfiber cloth and repeat the circular cleaning process. **DO NOT USE AN ORGANIC SOLVENT SUCH AS PAINT THINNER, ALCOHOL, OR BENZENE.**

LENS HOOD

The supplied hood is designed specifically for the Rokinon SP 50mm F1.2 lens for optimum effectiveness. It should be used at all times to provide better contrast and added protection. The only exception is if it blocks the light from a built-in or small electronic flash to cause a shadow at the bottom of the image.

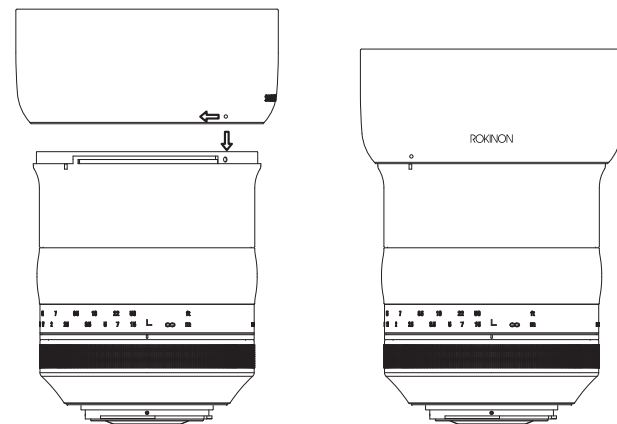

- To mount the hood, align the white dot on the hood with the white dot (NOT the vertical line) on the lens and rotate the hood clockwise until you hear and feel it click in place.
- To remove the hood, grasp it firmly near its base and turn counter clockwise.
- You can store the hood in its reverse position for easy transport. Reverse the hood so that it covers the lens barrel and again align the white dot on the hood with the white dot on the lens and rotate the hood clockwise until you hear and feel it click in place.

HOOD STORED IN REVERSE POSITION

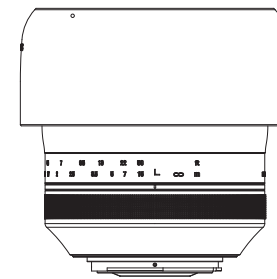

PRODUCT SPECIFICATIONS

MODEL	SP 50mm F1.2	
MOUNT	Canon EF	
ANGLE OF VIEW	FULL FRAME	46.6°
	APS-C	31.0°
MAXIMUM DIAMETER X LENGTH	3.66" x 4.62" (93mm x 117.4mm)	
WEIGHT	43.2oz (1200g)	
APERTURE RANGE	F1.2-16	
OPTICAL CONSTRUCTION	11 elements in 8 groups (Including 1 Aspherical and 1 High Refractive Index)	
MINIMUM FOCUSING DISTANCE*	17.7" (0.45m)	
MAXIMUM SHOOTING MAGNIFICATION	X 0.17	
FILTER SIZE	Ø 86 mm	
NUMBER OF APERTURE BLADES	9	

*The minimum focus is the distance from the image sensor to the object.

CONTACT

Elite Brands Inc.
Rokinon Division
New York, NY 10005

Toll Free: 800.441.1100
Phone: 212.947.7100
support@rokinon.com

rokinon.com
facebook.com/rokinonlenses
instagram.com/rokinon

ROKINON® is a registered trademark of Elite Brands Inc.
©2018, Elite Brands Inc., New York, NY 10005

The product specifications and design are subject to change without notice.