

● **21mm T1.5 CINE ED AS UMC CS**
(Sony E, Fujifilm X, Canon M, MFT)

Instruction Manual

The new 21 mm T1.5 CINE ED AS UMC CS lens from Samyang gives a special kind of filming experience.

The new 21 mm T1.5 CINE ED AS UMC CS lens is compact and conveniently portable through an optical design optimized for Canon M, Fujifilm X, Sony E and MFT mirrorless cameras.

It enables the photographer to shoot various types of images at both close range and far away.

Advantages of the 21 mm T1.5 CINE ED AS UMC CS lens:

1. Optical design responds to the image size of APS-C for mirrorless cameras
2. Corrects aberrations using 1 extra dispersion lens and 3 aspherical lenses and, in the fully open position, the entire lens view offers high resolution and high contrast, from the center of the lens to its periphery
3. The detachable petal type hood and UMC (Ultra Multi Coating) design suppresses flaring and ghost images
4. Ability to obtain clear images in low-light conditions through T1.5 brightness and beautiful out focusing using a shallow depth of field in accordance with the distance between camera and subject
5. Produces sharp images at distance and up close with a REAR FOCUS design
6. 9 aperture blades enable a circular aperture diaphragm
(Circular bokeh (out-of-focus areas) and star-like rays are expressed clearly.)
7. Suitable for shooting video due to quiet aperture ring operation and precision focusing

Read this manual carefully to familiarize yourself with correct use of your lens.

※ Please read the 'Safety Precautions' at the back of this instruction manual prior to use.

● Please read this instruction manual prior to use. ●

1. Component Names

[Figure]

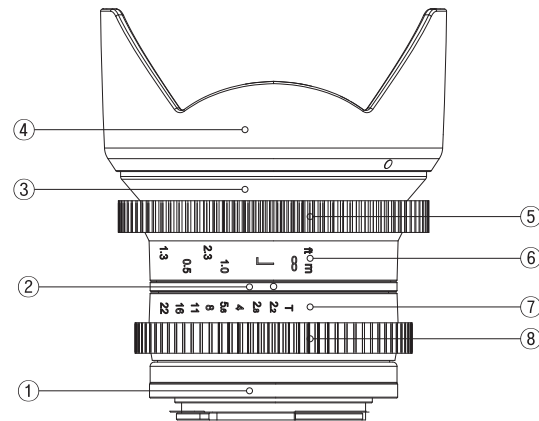

- | | | |
|------------------|----------------------------|---------------|
| ① Mount | ② Distance scale point | ③ Hood mount |
| ④ Hood | ⑤ Focusing gear | ⑥ Focus scale |
| ⑦ Aperture scale | ⑧ Aperture adjustment gear | |

2. Attaching to and Detaching from the Camera

[Attaching]

Gently hold the lens hood, align the camera mount attachment point with the camera locking reference point on the lens, push the lens into the camera and turn the lens gently until it makes a clicking sound, and the depth of field scale is positioned at the top of the camera.

[Detaching]

Gently hold the lens hood, press the lens release button on the camera, and turn the lens in the opposite direction to detach the lens.

3. Focus Adjustment

When using the 21mm T1.5 CINE ED AS UMC CS lens, you can set the focus of a subject by turning the focusing ring, since it is an MF (Manual Focus) adjustment lens.

[Canon M, Fujifilm X, Sony E, MFT Mount]

- ① To change the focus from a subject that is far away to a subject that is close turn the focusing ring clockwise (from ∞ to 0.28) and focus on the clearest subject, using the indicator signal on the camera or by checking on the LCD.
- ② To change the focus from a subject that is close to a subject that is far away turn the focusing ring counterclockwise (from 0.28 to ∞) and focus on the clearest subject, using the indicator signal on the camera or by checking on the LCD.

4. Brightness Control

Turn the aperture adjustment gear to set the desired brightness for the 21mm T1.5 CINE ED AS UMC CS lens.

You can set T NO from 1.5 to 22.

(The aperture is not positioned at any exact point, since it is adjustable continuously without steps.)

5. Mounting a Hood

The bayonet-type hood guarantees speedy, efficient, safe and precise installation and facilitates shooting that is free from ghosting or flaring.

[Figure]

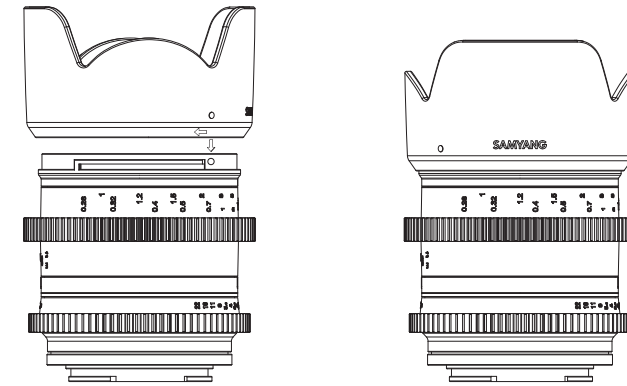

Align the attachment reference point on the hood with the hood reference point on the lens, push the hood onto the lens and turn the hood clockwise until it makes a clicking sound.

6. Camera settings

[Canon M Mount]

- 1) Record a video in Av, Tv, P, CA and M mode.
- 2) Please note that while recording a video the shutter speed is limited to a minimum of 1/30.

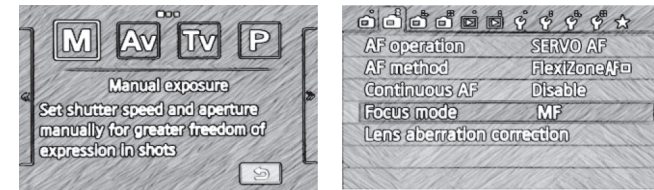

(The procedures above are for the Canon M. The settings for the camera or the menu may vary based on the camera model or due to a functional upgrade. Refer to the camera instruction manual or contact the camera manufacturer for detailed information.)

[Fujifilm X Mount]

- 1) Record a video in mode.

(The procedures above are for the X-pro 1, The settings for the camera or the menu may vary based on the camera model or due to a functional upgrade. Refer to the camera manual or contact the camera manufacturer for detailed information)



- 2) Press the MENU/OK button, and select ON for 'Shooting without lens' in the shooting menu.
When the shooting mode is for video recording, you need to change the mode to still image.

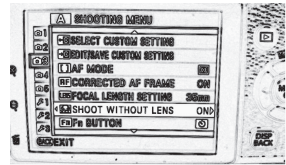

(The above procedure is given based on the X-Pro1. The camera settings may be different depending on the model or due to a menu upgrade. Therefore refer to the camera manual or contact the camera manufacturer for more detailed information.)

【Sony E Mount】

- Record a video in A, S, P, M mode.
- Please note that while recording a video the shutter speed is limited to a minimum of 1/30.

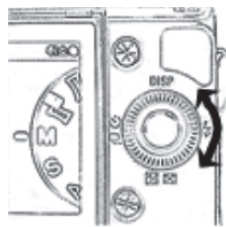

※ For some Sony E cameras, if you set the camera mode dial to A and set the brightness by turning the aperture adjustment ring on the lens, the camera automatically changes the shutter speed, so you don't have to adjust the shutter speed as well, which is required in M mode.

(The procedures above are for the NEX-5, The settings for the camera or the menu may vary based on the camera model or due to a functional upgrade. Refer to the camera manual or contact the camera manufacturer for detailed information)

【Micro Four-Thirds Mount】

- Record a video in A, P, M and mode.
- Please note that while recording a video the shutter speed is limited to a minimum of 1/30.

(The procedures above are for the E-5, The settings for the camera or the menu may vary based on the camera model or due to a functional upgrade. Refer to the camera manual or contact the camera manufacturer for detailed information)

7. SPEC					
SPECIFICATIONS		T1.5 21mm CINE ED AS UMC CS			
APERTURE RANGE (T-STOP)		T1.5 to T22			
OPTICAL CONSTRUCTION		8 ELEMENTS IN 7 GROUPS (3 ASPHERICAL LENSES)			
MINIMUM FOCUSING DISTANCE		0.28m(0.92ft)			
FILTER SIZE		Ø 58.0mm			
MAXIMUM DIAMETER		Ø 73.6mm			
MOUNT		CANON M	FUJIFILM X	SONY E	MICRO FOUR-THIRD
ANGLE OF VIEW	APS-C	66.4°	69.3°	69.3°	-
	FOUR-THIRDS (4/3")	-	-	-	55.6°
LENGTH		67.5mm	67.9mm	67.6mm	66.4mm
WEIGHT		290g	305g	290g	300g
GEAR	MODULE	0.8			
	A	7.5mm			
	B	6.0mm			
	C	30.4mm			
	D	16.4mm	16.8mm	16.5mm	15.3mm
	FOCUS DIAMETER	Ø 73.6mm			
APERTURE DIAMETER		Ø 70.4mm			

8. Troubleshooting

Symptom	Cause	Action
The lens cannot be attached to the camera.	The reference point on the lens is not aligned with the lens attachment reference point on the camera.	Align the reference point on the lens with the lens attachment reference point on the camera.
The lens cannot be detached from the camera.	Incorrect rotation direction for detaching the lens. If you turn the lens while holding the camera, it may cause damage to the lens.	Press the lens release button on the camera, and lightly turn the lens to the lens attaching/detaching reference points, in the direction as marked on the camera, and then pull the lens forward.
Dark image.	Incorrect focusing. Insufficient shutter speed, or camera shake.	Turn the focusing ring while checking the subject using the indicator in the camera or checking visually to set the focus until the subject is clear and distinct, and then press the shutter. After selecting a shutter speed of 1/125 sec or faster, steady the camera and take a photograph.
Automatic focusing does not work properly.	This is a manual focus lens and does not have an automatic function.	Turn the focusing ring to focus on a subject.
The pictures are too dark or too bright.	The exposure is incorrect.	Set the aperture adjustment ring of the lens and the camera shutter speed appropriately.
The edges of the picture periphery gets dark when using a manual camera or a digital camera with a 1:1 image sensor.	As this lens is optimized for APS-C size images, the edges of the picture look dark when using a digital camera with 1:1 sized images.	Use a camera with for APS-C sized images.
The camera flash is not synchronized to the camera.	A manual control lens may not be compatible depending on the camera.	See the camera manual.
There is no camera finder indication or display.	This lens does not have electronic contacts, so there is no communication with the camera.	This does not indicate that there is a problem with shooting.
Zoom failure.	This lens is a short focus lens.	
The lens hood cannot be detached.	This lens hood is of the fixed type, so it cannot be detached.	
The lens cannot be mounted on other cameras.	This lens is designed a specific mount type.	Please buy the required camera to use this lens.
I want to attach your 2X or 1.4X converter lens.	Our converter is designed for the T (M42 SCREW) mount only, thus it cannot be used with this product.	Use each company's own mount converter. However, be aware that auto focusing will not be available.

9. Safety Precautions

The following precautions are divided into two types according to the level of danger.

WARNING
If this instruction is not followed, it may cause death or severe injury to the user.

CAUTION
If this instruction is not followed, it may cause death or severe injury to the user.

The following pictograms are used in the below precautions:

Requires caution. Inside the pictogram it shows contents of precautions. (It shows outbreak of fire in the pictogram on the left.)
 Shows prohibition. Inside the pictogram it shows contents of prohibition. (It shows prohibition of dismantling in the pictogram on the left.)
 Shows instruction. Inside the pictogram it shows contents of instructions. (It shows instruction of precaution in the pictogram on the left.)

WARNING	CAUTION
<p>Don't look at the sun through the lens. It may cause blindness.</p>	<p>Attach the lens to the camera correctly and ensure the lens is held in place properly, otherwise the lens may become loose and cause an accident.</p>
<p>Don't leave the lens within reach of babies, as it may cause injury to the baby if the lens falls or is dropped.</p>	<p>Don't attempt to modify or alter the lens. It may lead to failure of the camera. Modified or altered lenses may not be repaired.</p>
<p>Don't leave the lens in direct sunlight. It may cause a fire, depending on lenses that concentrate light on a close object.</p>	<p>Ensure that the camera operates properly by checking the lens beforehand or by test shooting for important events such as a wedding ceremony and an overseas trip.</p>
<p>Don't look at the sun directly through a camera with a lens attached. It may cause damage to one's eyesight.</p>	

WARNING!
Do not allow this product to get wet, or expose it to a moist environment. It may cause a fire or electric shock.

- CAUTION!**
- Do not use this product or store it close to devices that generate heat i.e., heaters, thermal regulators, stoves, stereo amplifiers.
 - Do not expose the lens to drastic temperature changes.
 - Do not touch the surface of the lens with your hand, or let it come into contact with sharp objects.
 - Do not drop the lens.
 - Do not soak the lens in water, and avoid water splashing onto the lens.
 - If there are foreign bodies on the lens, use a lens cleaning kit only.
 - If the hood is removed, the surface of the lens will be exposed and may become scratched, or break.