



User Guide: the S7 Stereo Microscope Series



Welcome to your Swift S7 Series microscope! Whether you are a seasoned professional or a beginner hobbyist, Swift has the perfect microscope for you.

This guide will introduce you to the components of your new microscope and help you begin using it. For more information about our microscopes, software downloads, product manuals, or customer service requests, please visit www.swiftoptical.com.

Table of Contents

I. Prior to use	2
II. Specifications	2
III. Parts of the microscope	4
IV. Assembling the microscope	14
V. Using the microscope	25
VI. Maintenance and repair	26
VII. Troubleshooting	27
VIII. Warranty information and customer support	28
IX. Manual and software downloads	29

I. Prior to use

Your microscope is a precision instrument that will last you for many years with proper care and use. Keep these instructions in mind:

1. Store the microscope in a clean and dry place. Keep the microscope out of direct sunlight. Avoid extreme temperature changes and humidity.
2. Handle with care at all times, avoiding impact or abrupt movement during transport.
3. For best image clarity, do not leave fingerprints or other markings on any lenses.
4. Never turn the right and left focusing knobs in opposite directions at the same time. Doing so will damage the microscope.

II. Specifications

The S7 series comes with either a binocular (S7-B) or a trinocular head (S7-T) and is highly customizable with optional additional eyepieces, objectives, illumination rings, and stands. The S7-T features a dedicated port for camera attachments. The below specifications show the standard models and which customizations are available.

S7 Series model specifications

Model Type	S7-B	S7-T
Observation head	Binocular	Trinocular
Optical system	Greenough	
Observation angle	45°	
Interpupillary adjustment	54- 76 mm	
Diopter adjustment	On left and right tubes, +/-5	
Zoom range	0.7X—4.5X, standard	
Zoom ratio	1:6.4	
Eyepieces	WF10X/20mm, standard	
Magnification	7X-45X, standard	

Auxiliary Objective	0.5X, 2X, optional	
Focusing travel range	50mm	
Working distance	100mm, standard	
Illumination options	Upper incident and bottom LED lights for S7-BL, S7-TL Upper gooseneck and bottom LED lights for S7-BGL, S7-TGL LED ring light for S7-BP, S7-TP, S7-BS, S7-TS, S7-BD, S7-TD	
Camera adapter	-	0.5X C-mount adapter, optional Φ23.2mm eyepiece camera adapter, optional
Stand options	Upper incident and bottom transmitted stand Upper gooseneck and bottom transmitted stand Plain stand, Single-arm boom stand, Dual-arm boom stand	

S7 Series optics specifications

Eyepiece	Standard Configuration	
	WD 100mm	
	Mag.	FOV (mm)
10X (20mm)	7X	28.6
	45X	4.4

Abbreviations:

WD = Working distance

Mag = Magnification

FOV = Field of view

III. Parts of the microscope

The below diagrams show the various available stand configurations for the S7 binocular and trinocular head models.

1.The S7-BP with plain stand

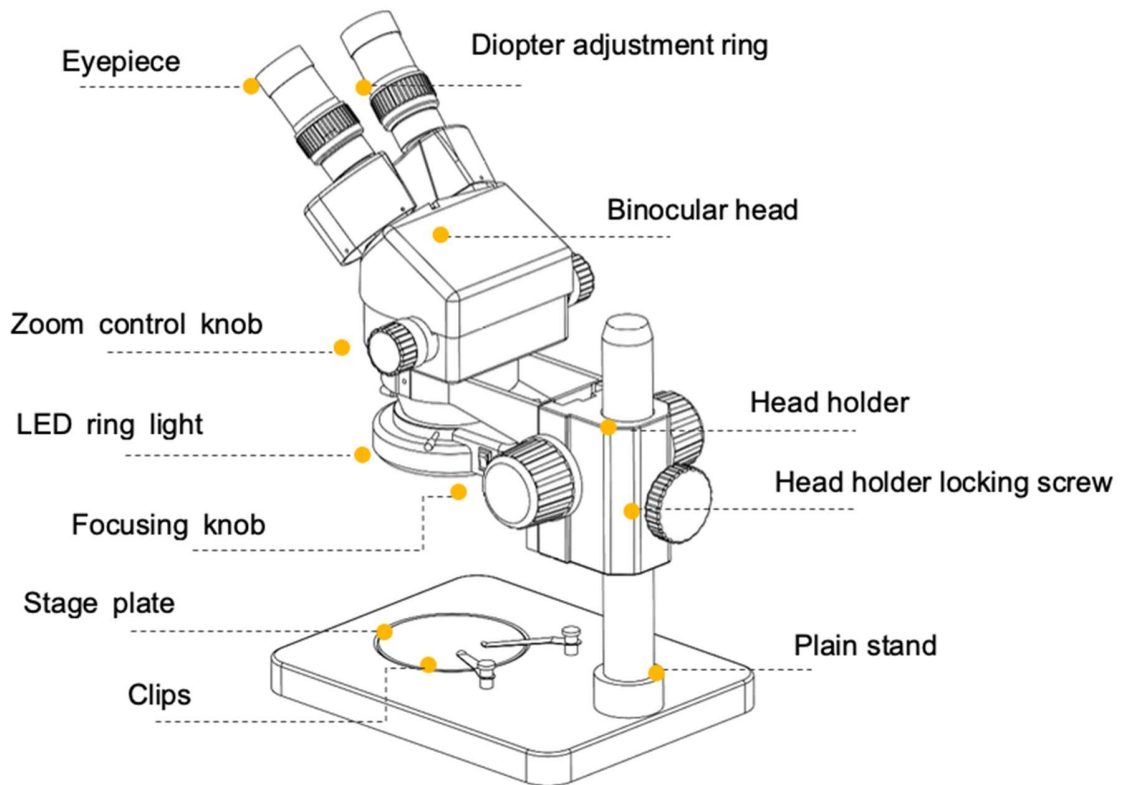

Fig.1

2. The S7-BL with upper incident and bottom transmitted stand

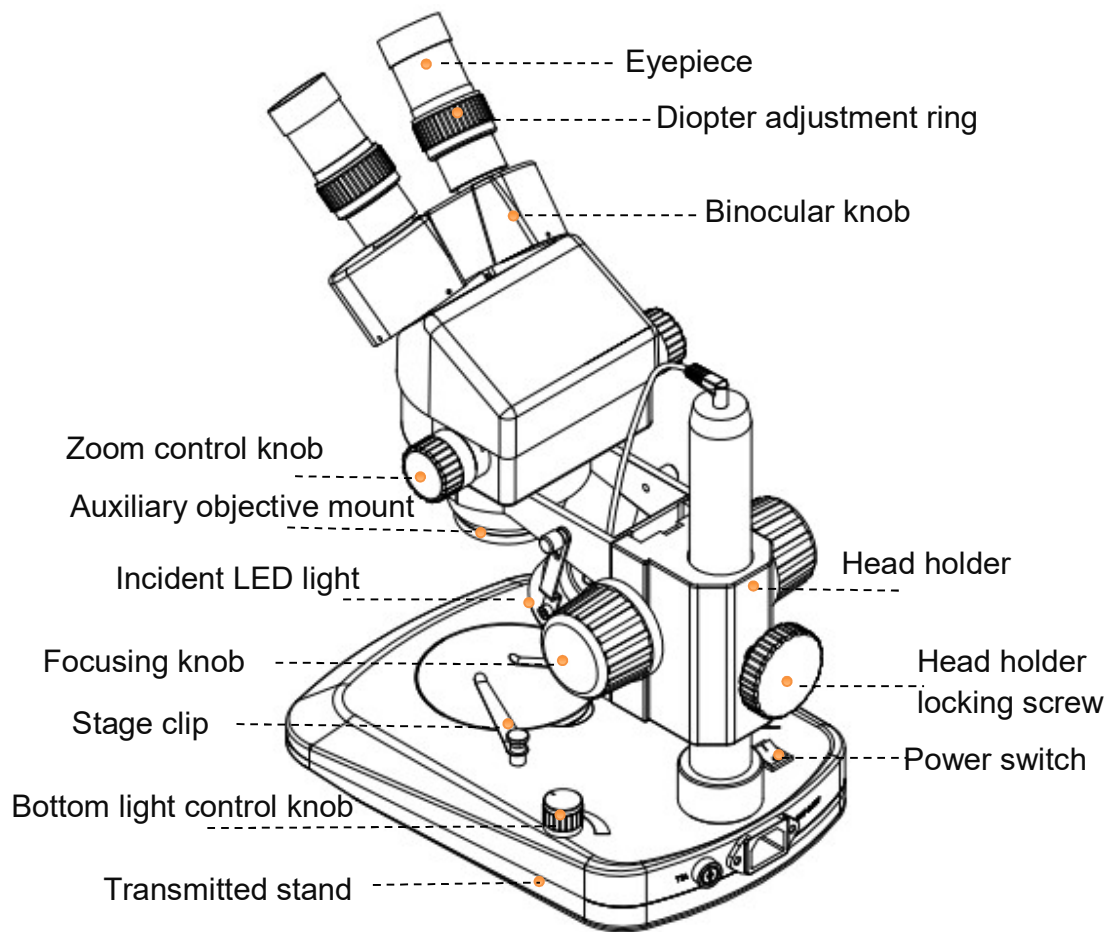

Fig.2

3. The S7-BGL with upper gooseneck and bottom transmitted stand

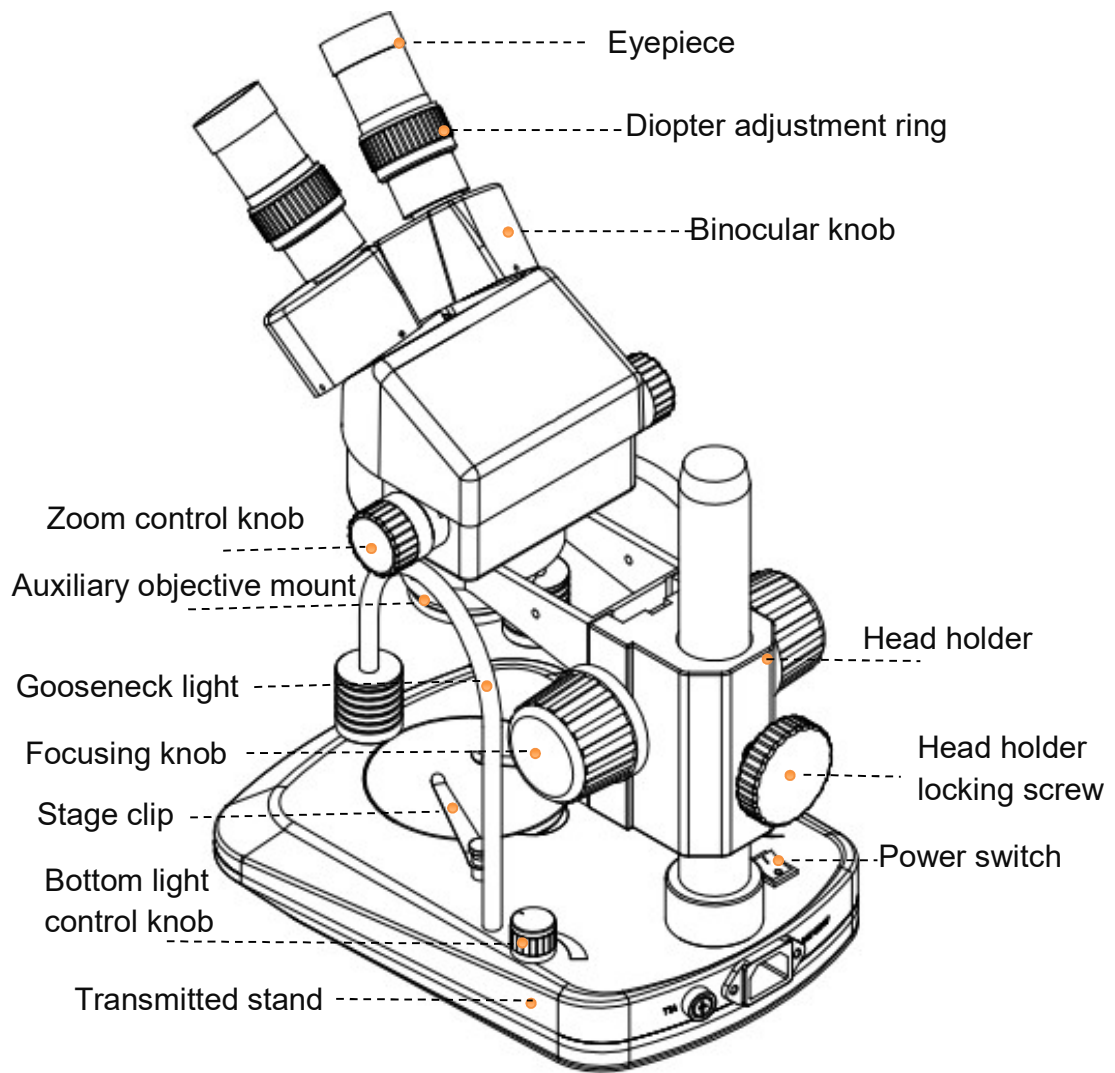

Fig.3

4.The S7-BS with single-arm boom stand

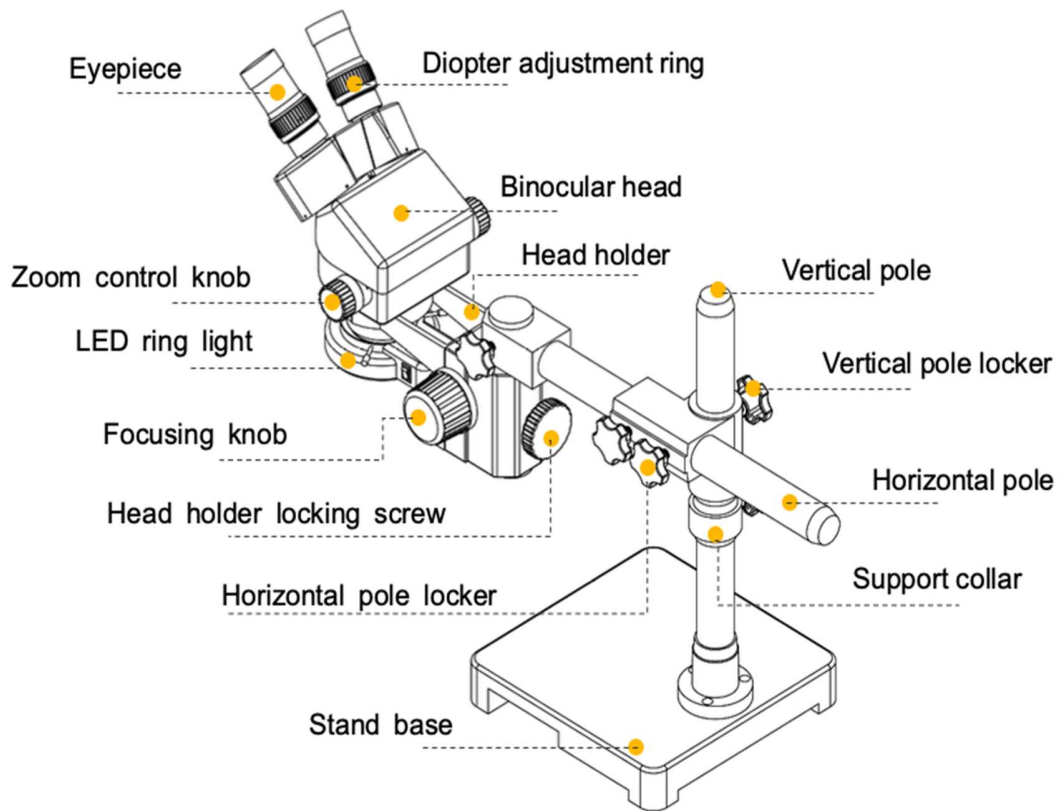

Fig.4

5.The S7-BD with dual-arm boom stand

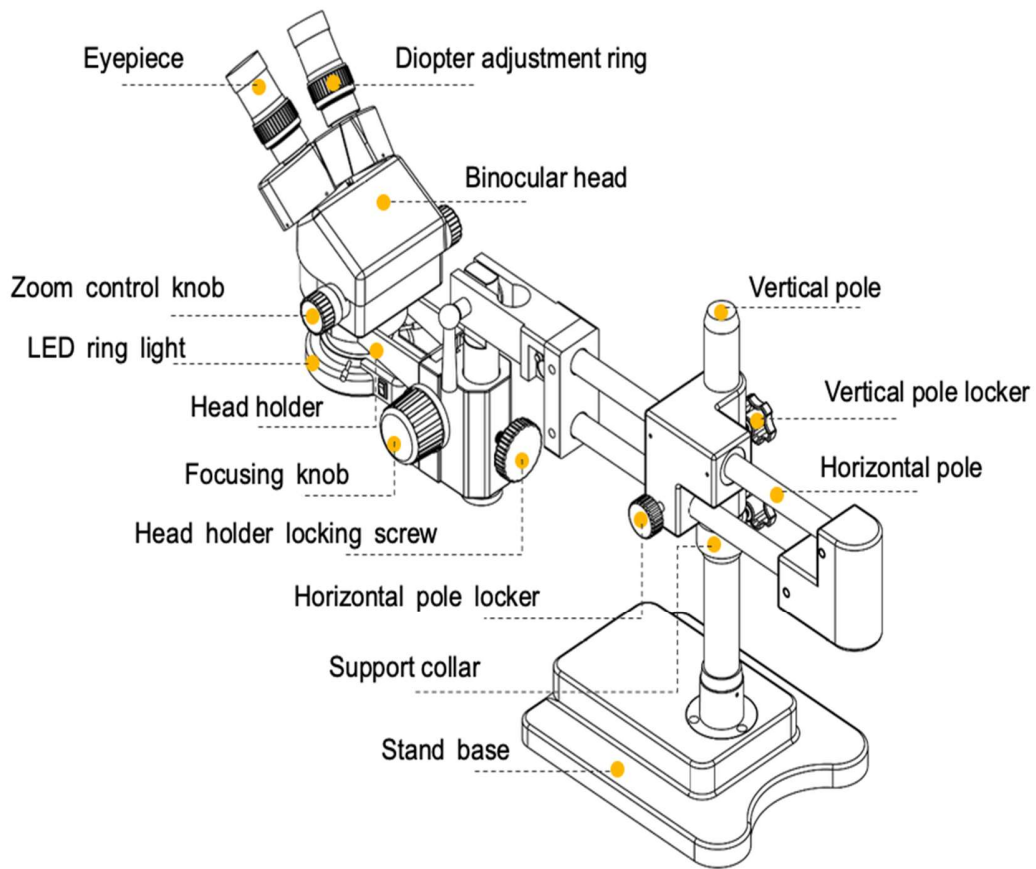

Fig.5

6.The S7-TP with plain stand

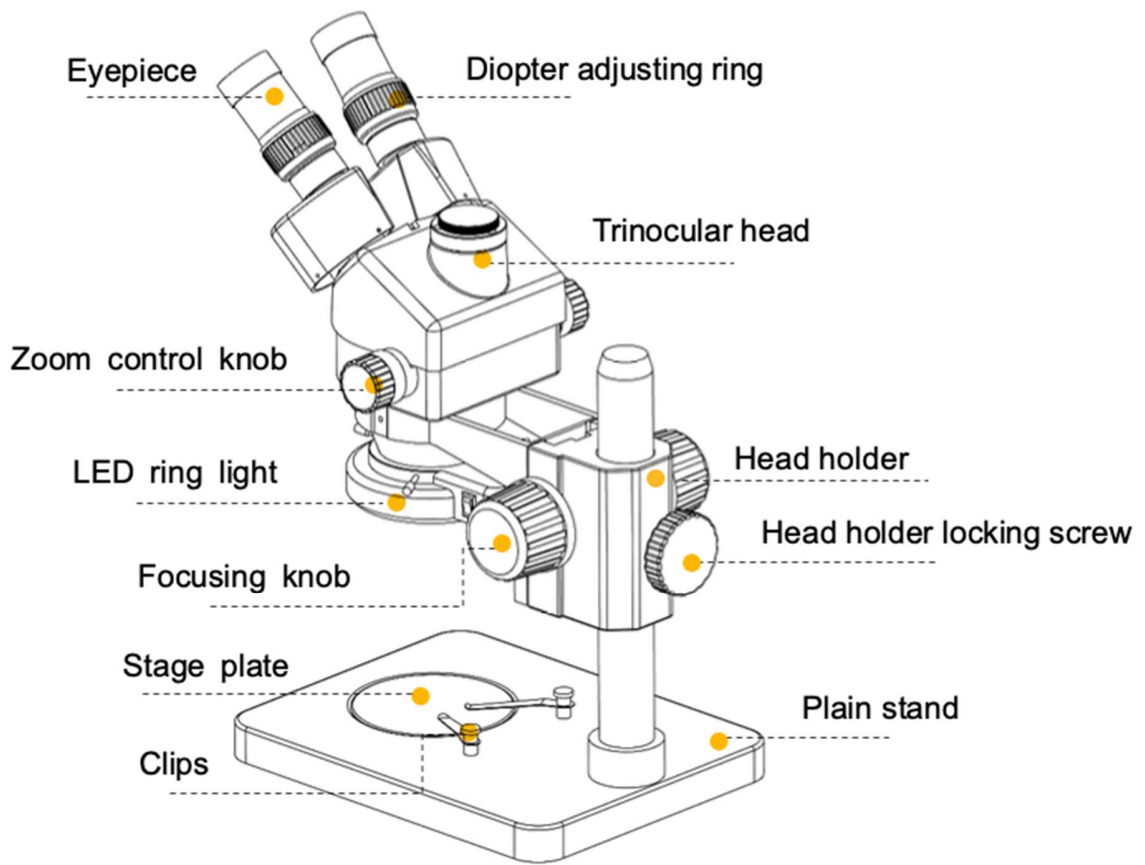

Fig.6

7.The S7-TL with upper incident and bottom transmitted stand

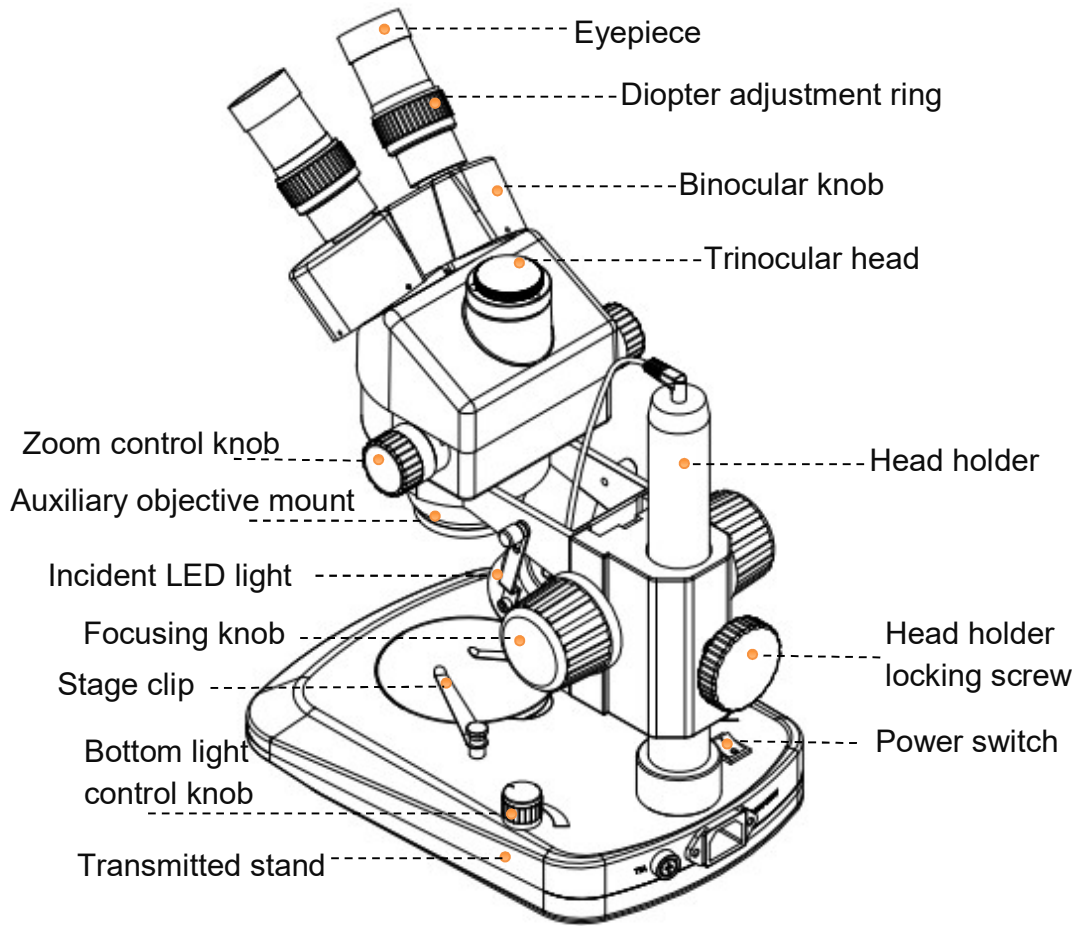

Fig.7

8.The S7-TGL with upper gooseneck and bottom transmitted stand

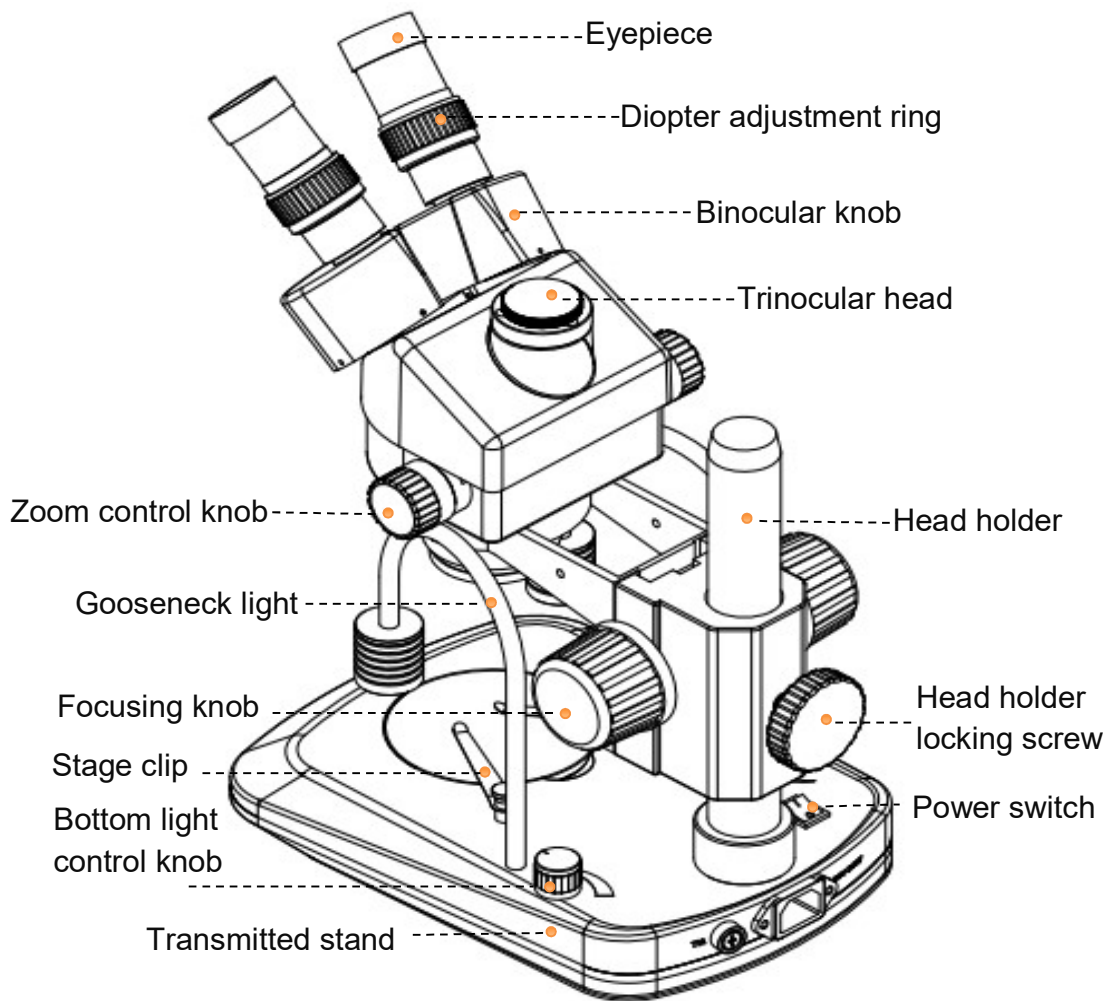

Fig.8

9.The S7-TS with single-arm boom stand:

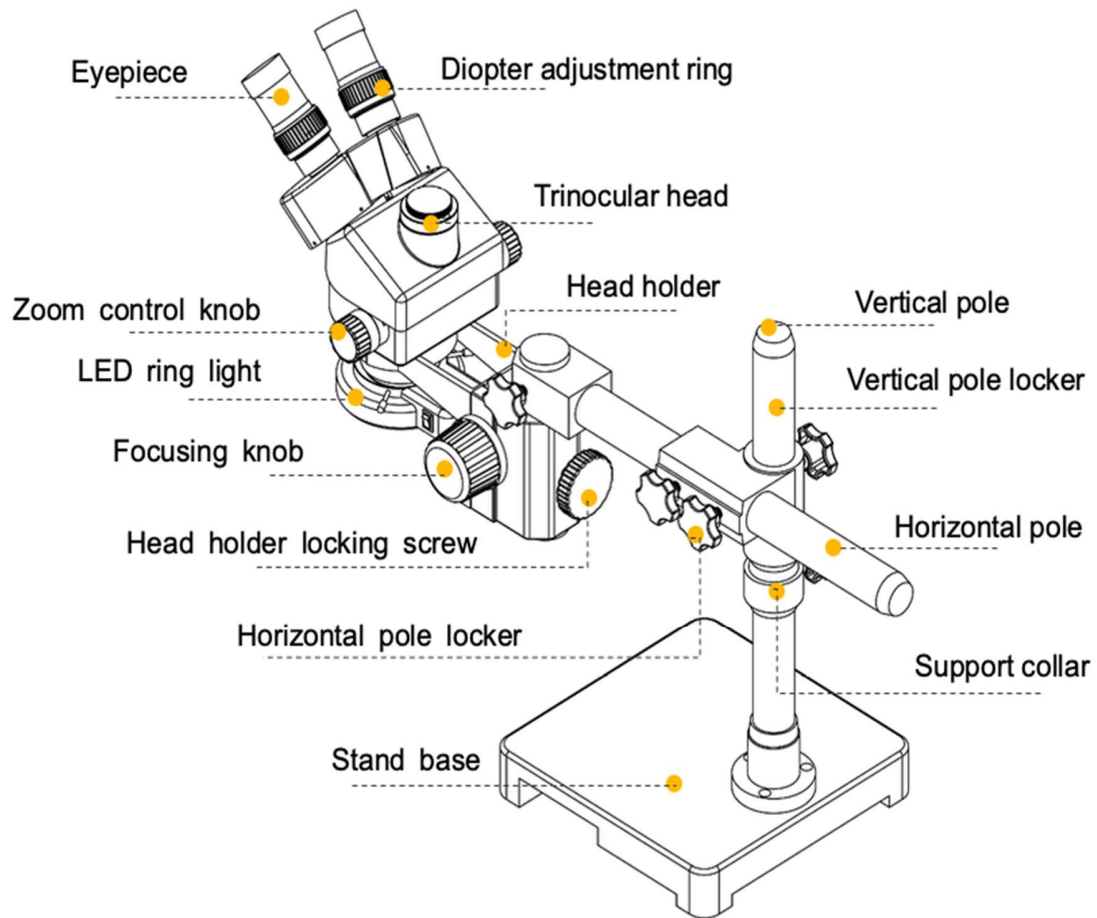

Fig.9

10.The S7-TD with dual-arm boom stand:

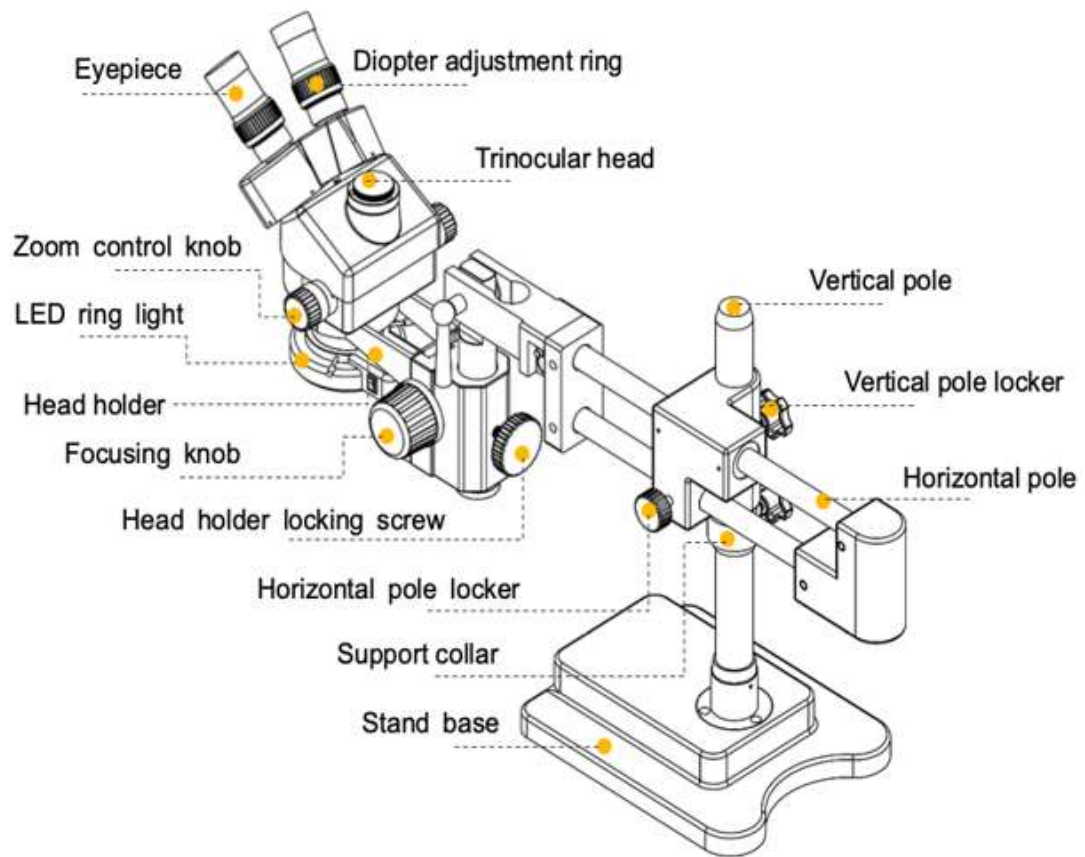

Fig.10

IV. Assembling the microscope

The components for the S7 series microscopes are shipped detached for protection. Open the Styrofoam packing with care and do not leave any components attached to the packing being removed. Do not discard any of the packing materials until all of the components have been identified. Refer to the appropriate diagram from Section III to identify all the components.

When handling the components, especially the optical pieces, avoid touching any lens surfaces with bare hands or fingers, as fingerprints and grease stains affect image quality.

Always assemble the microscope on a flat, stable surface.

There is anti-theft design of S7 eyepiece with the eyepiece locking screw in the microscope eye tubes. Please loose the cross recessed screw in the tubes and slide eyepieces into it. Tighten the locking screw after your eyepiece installation.

Refer to the appropriate diagrams on the following pages for how to assemble the pieces for your specific S7 model.

For all models, note that the column stand allows for extreme flexibility in positioning once assembled. Loosen the locking screw of the head holder or vertical pole locker (boom stand), adjust the height of the head holder and lock the locking screw again. Make sure that the support collar is secured firmly below the head holder or boom stand main body holder along the vertical post. This is important as this collar keeps the microscope from sliding down the column.

1.The S7-BP with plain stand

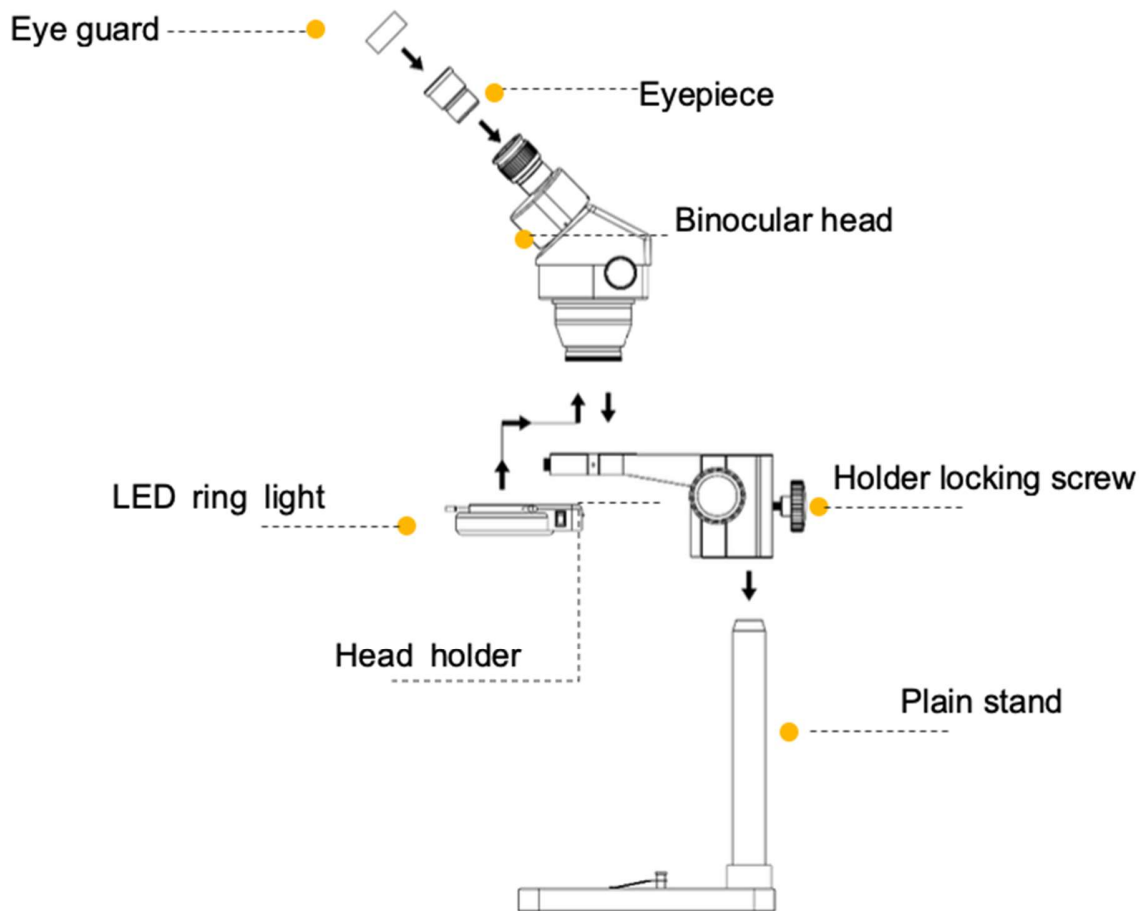

Fig.11

*Note: the ring light should only be attached to the bottom of the microscope head *after* the head has been securely inserted into the head holder.

2.The S7-BL with upper incident and bottom transmitted stand

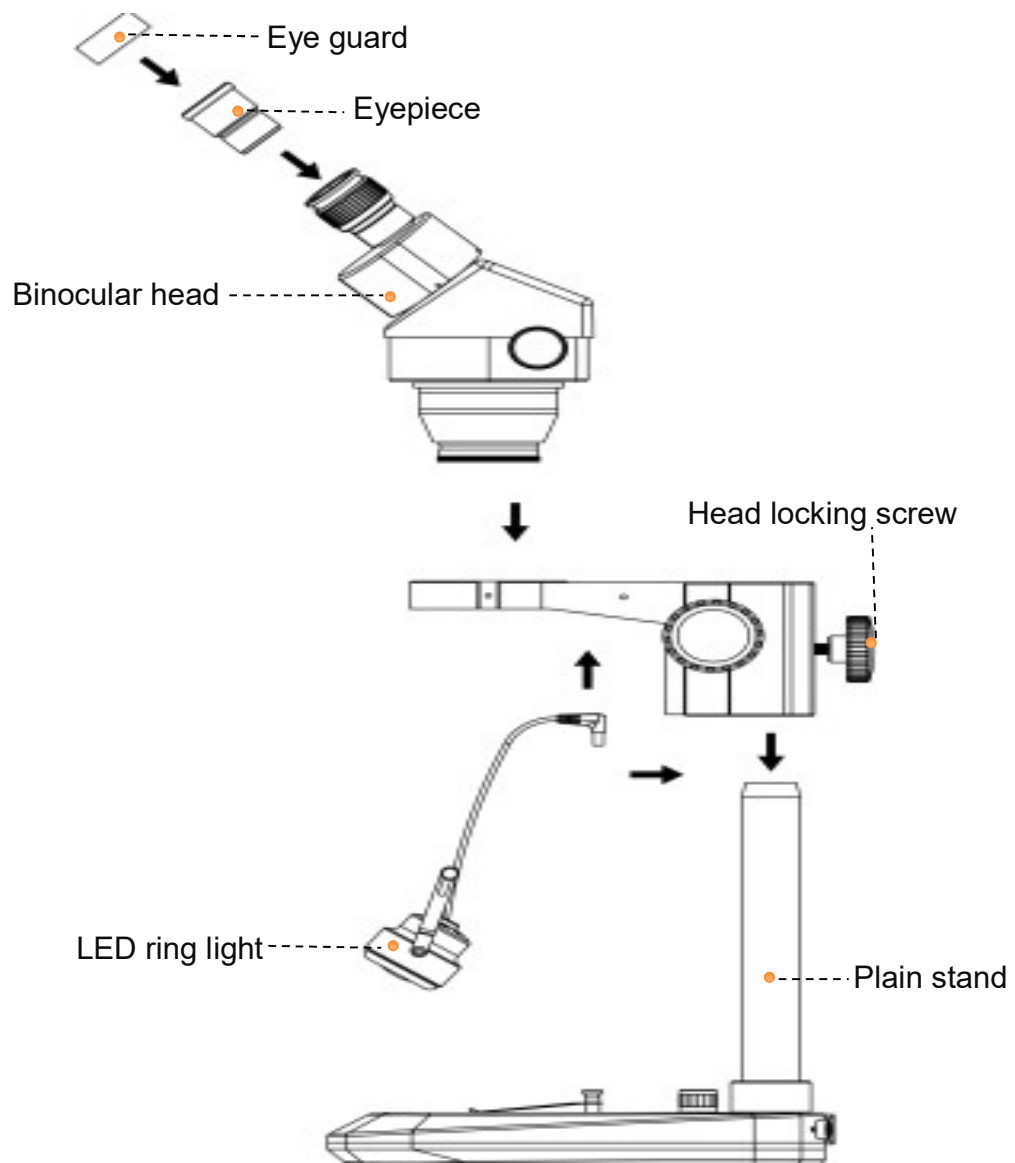

Fig.12

3.The S7-BGL with upper gooseneck and bottom transmitted stand

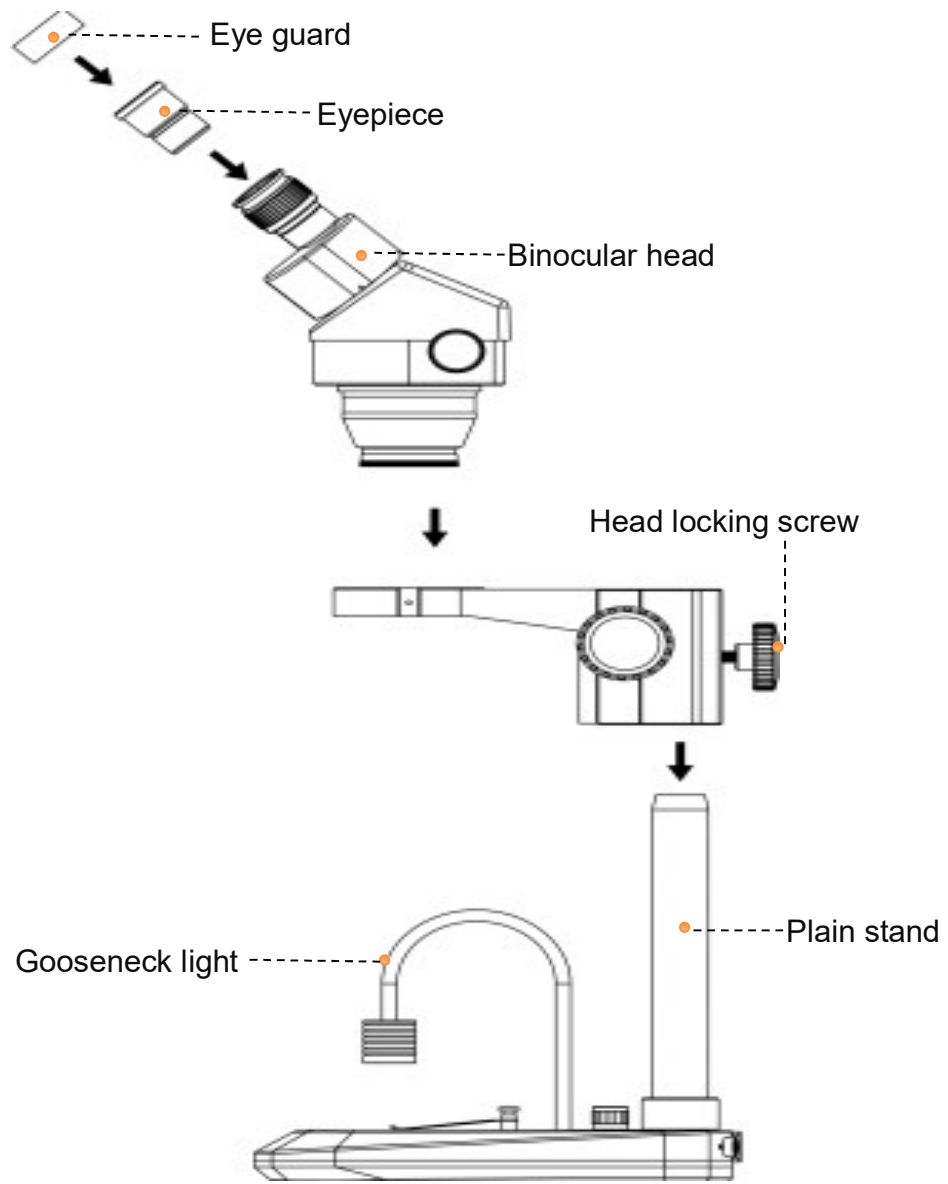

Fig.13

4.The S7-BS with single-arm boom stand:

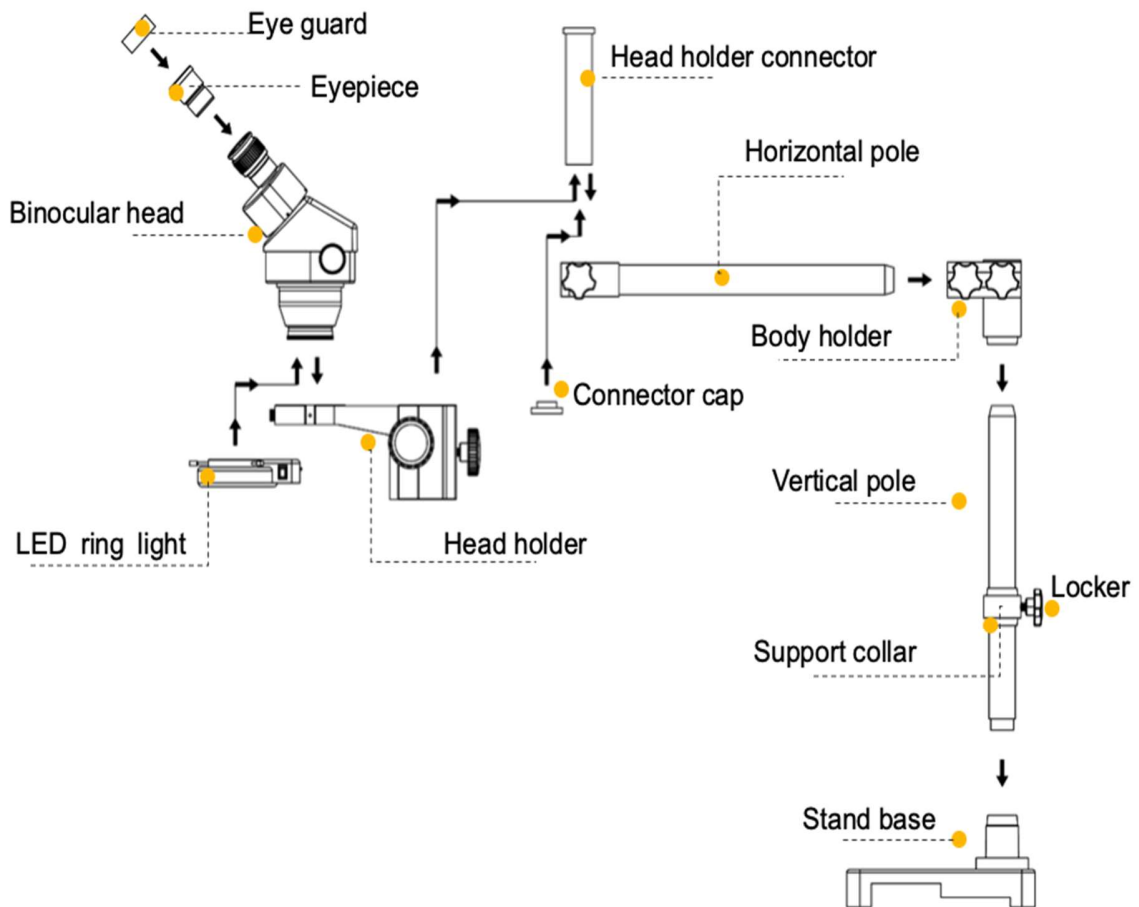

Fig.14

*Note: the ring light should only be attached to the bottom of the microscope head *after* the head has been securely inserted into the head holder.

5.The S7-BD with dual-arm boom stand:

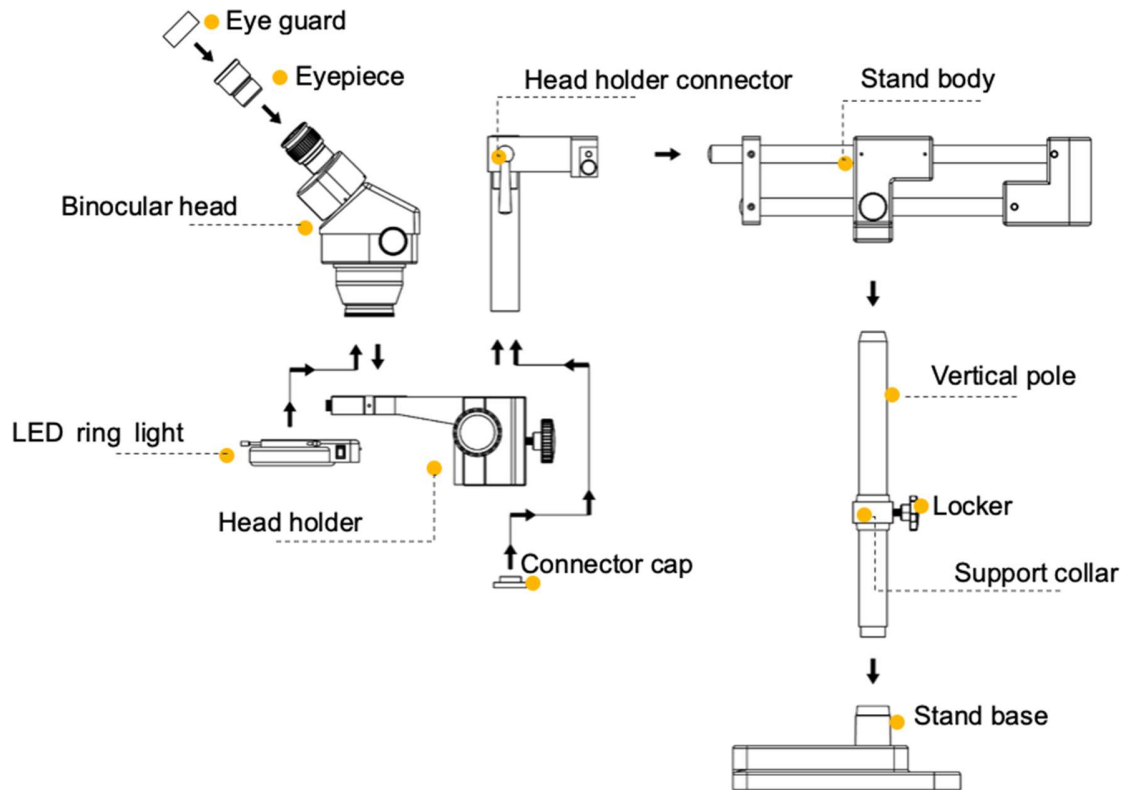

Fig.15

*Note: the ring light should only be attached to the bottom of the microscope head *after* the head has been securely inserted into the head holder.

6.The S7-TP with plain stand

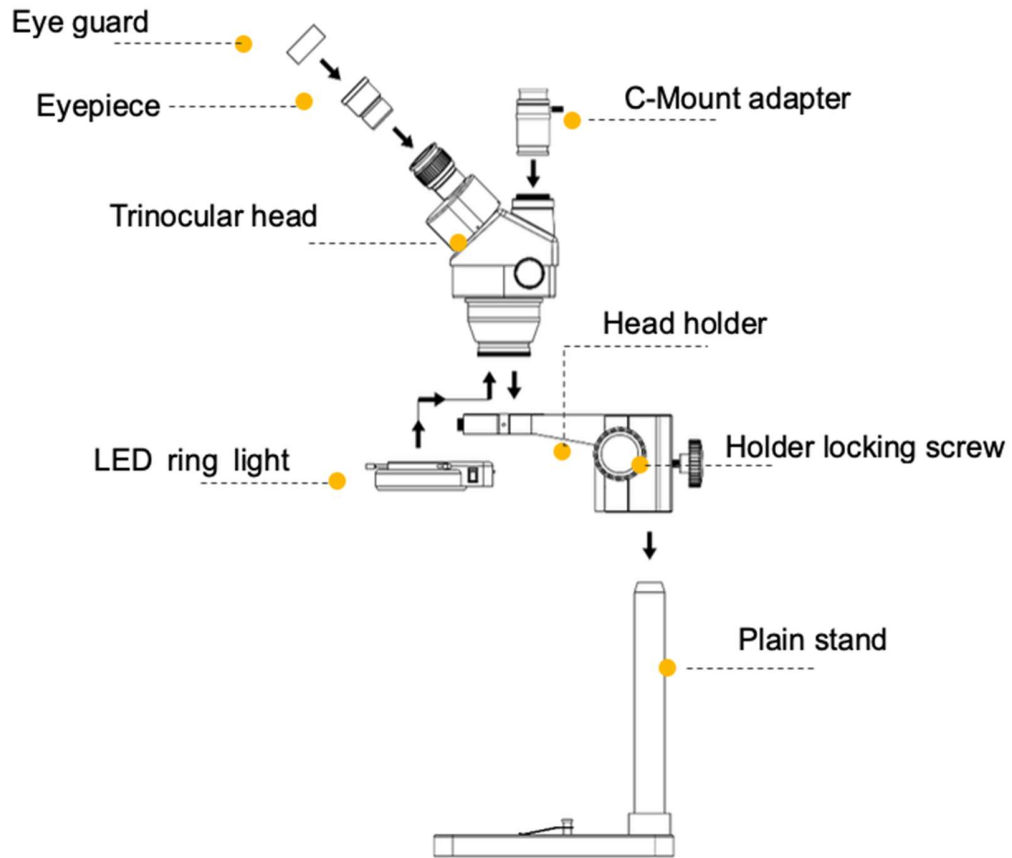

Fig.16

*Note: the ring light should only be attached to the bottom of the microscope head *after* the head has been securely inserted into the head holder.

7.The S7-TL with upper incident and bottom transmitted stand

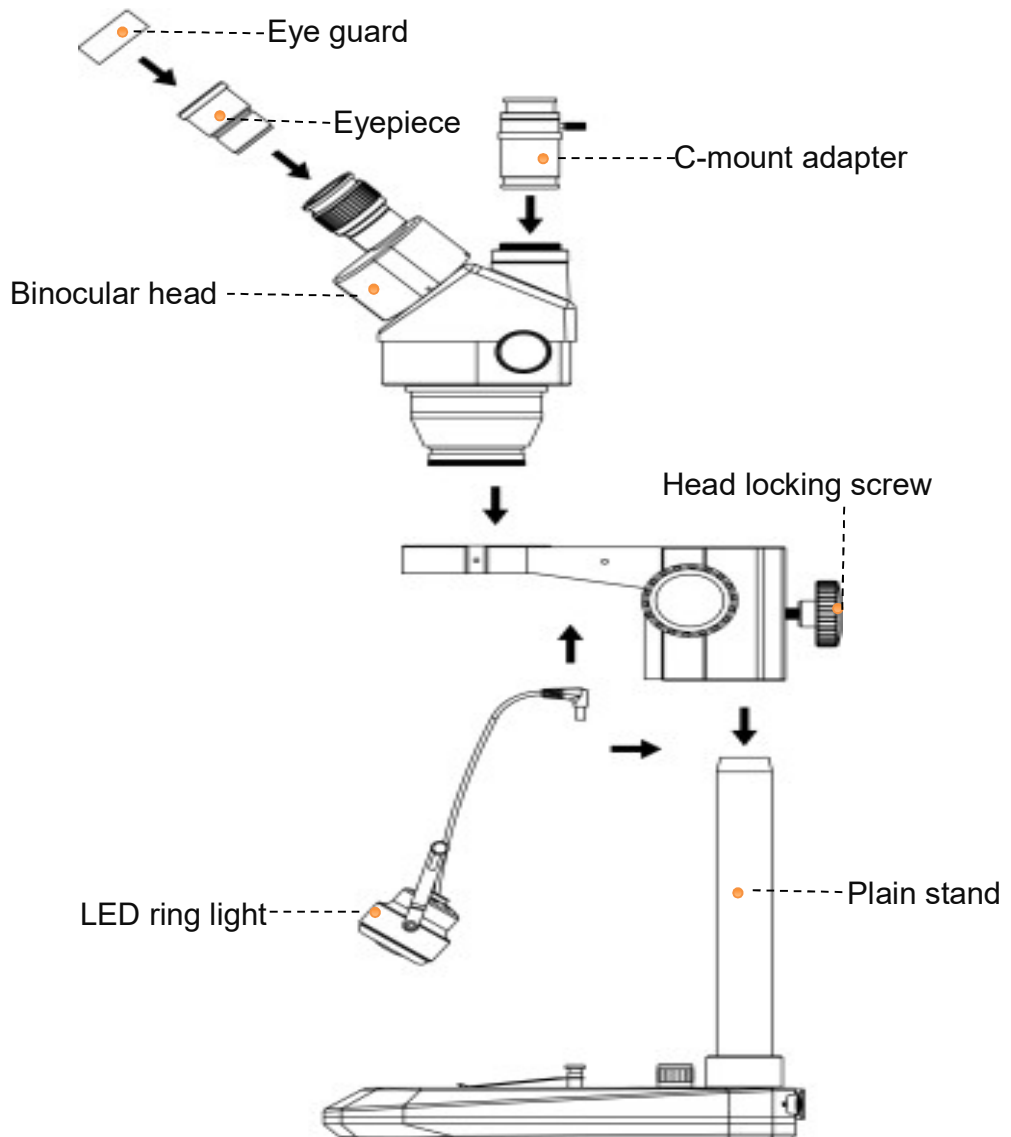

Fig.17

8.The S7-TGL with upper gooseneck and bottom transmitted stand

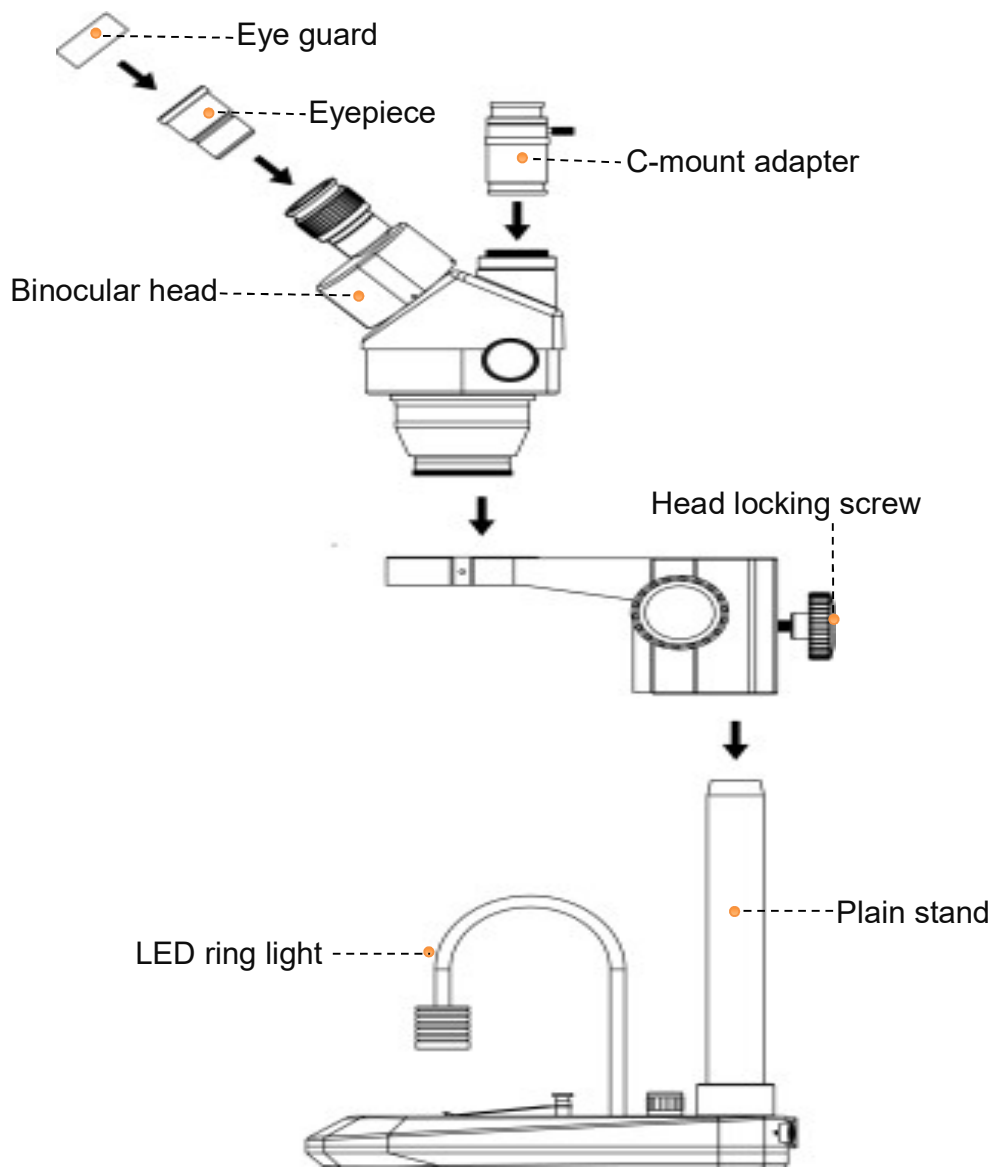

Fig.18

9.The S7-TS with single-arm boom stand:

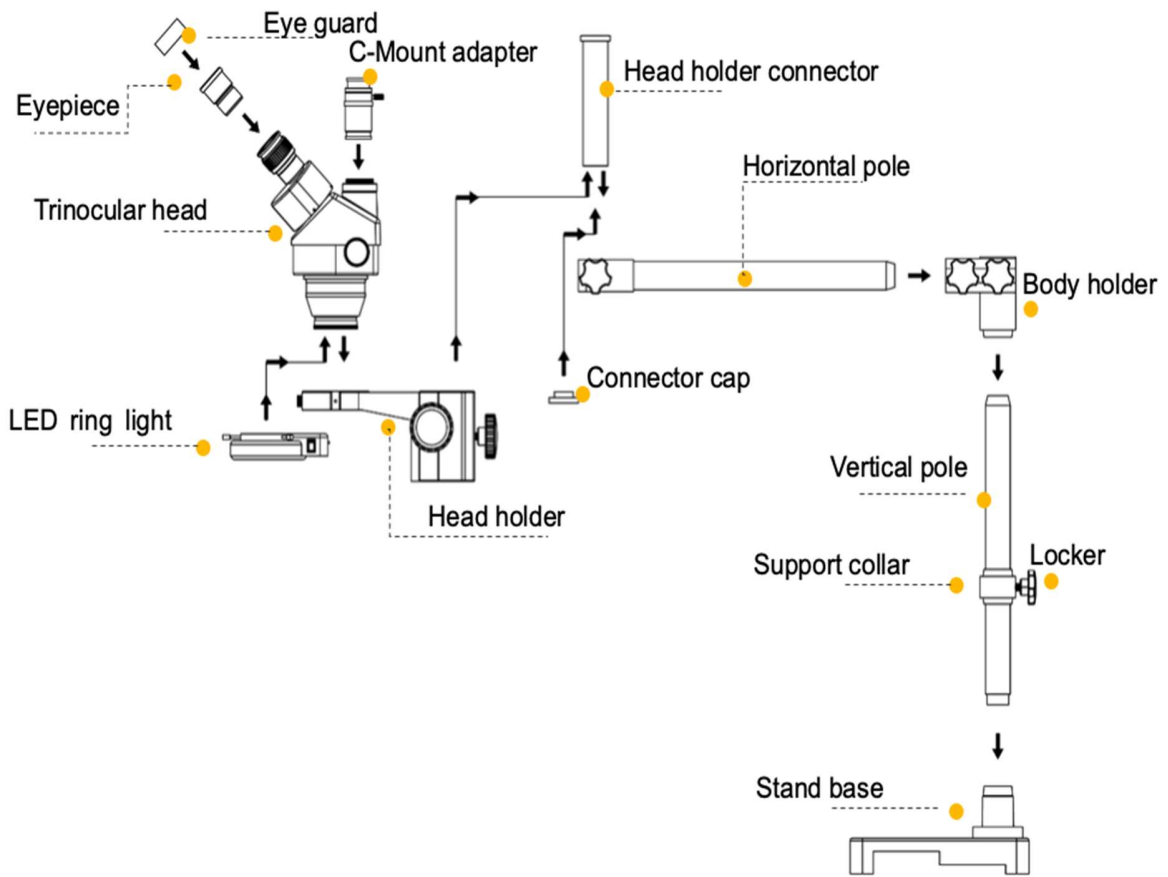

Fig.19

*Note: the ring light should only be attached to the bottom of the microscope head *after* the head has been securely inserted into the head holder.

10.The S7-TD with dual-arm boom stand:

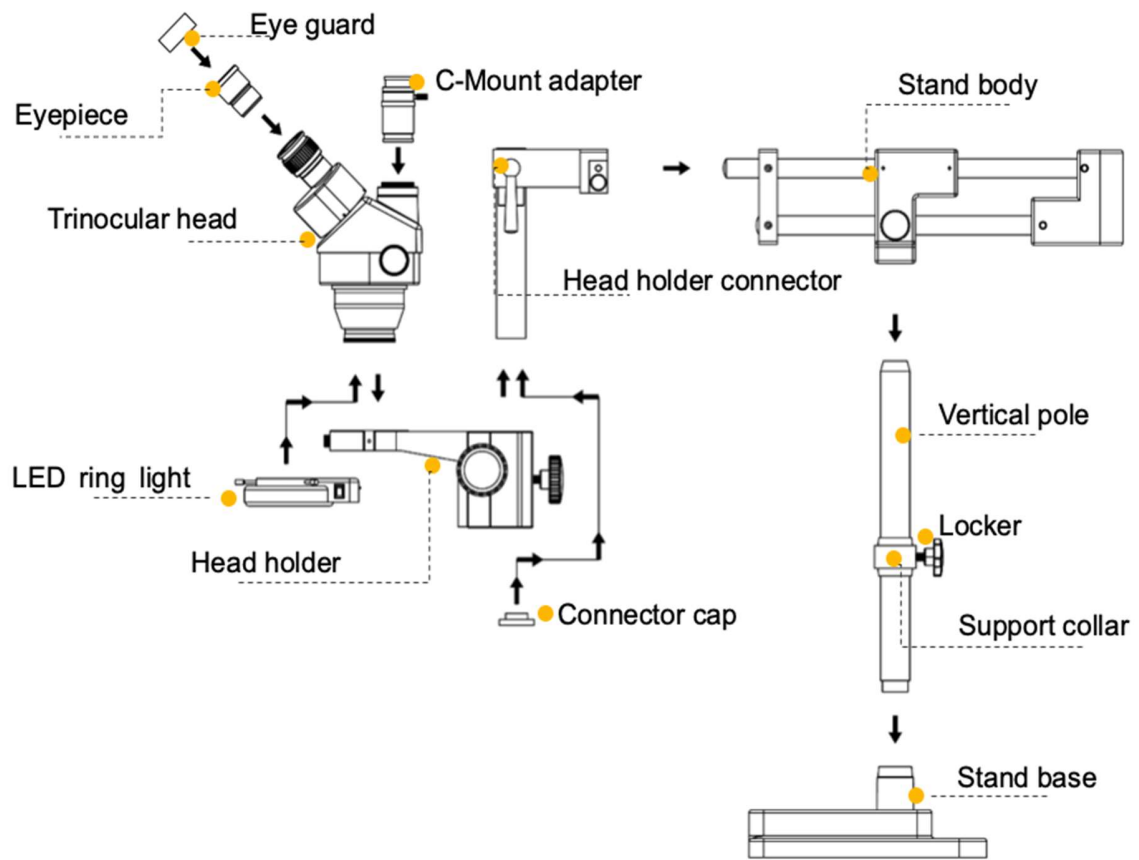

Fig.20

*Note: the ring light should only be attached to the bottom of the microscope head *after* the head has been securely inserted into the head holder.

V. Using the microscope

Interpapillary adjustment

Adjust the two eyepiece tubes until only one circular field can be seen through the two eyepieces. If two separate circles appear, the interpupillary distance is too large; if two overlapping circles appear, the interpupillary distance is too small. The eyepiece tube allows a flexible adjustment of the interpupillary distance between 54 and 76mm.

Focusing the microscope

To focus the sample, use the focusing knobs located on both sides of the head holder. By turning these knobs, the microscope can be moved up or down a certain distance. This movement is enabled by a “rack and pinion” mechanism. The tension of the focusing knob can be adjusted using the tension knob located in the inner region of the focusing knob on the right.

Using the focusing knob, focus the sample using the highest magnification strength. If the sample cannot be brought into focus, adjust the height of the microscope along the vertical pole. Remember to tighten the locking screw and support collar after adjusting the height of the microscope.

Turn the zoom to the highest magnification. Adjust the focusing knob until a clear and sharp image is obtained.

Turn the zoom to the lowest magnification. Adjust the right eyetube diopter until the image seen through the right eyepiece is clear and sharp.

Repeat the procedure for the left eye tube. Next, check the image focus for the entire zoom range; it should now be perfectly parfocal.

Using an auxiliary objective

To add an additional objective to the microscope, screw it onto the bottom part of the stereo head. The height of the microscope must be re-adjusted as the working distance will change when an additional objective is attached.

Magnification and working distance

Select the desired magnification strength by adjusting the zoom knob. Change the optional eyepieces and/ or add an optional auxiliary objective to increase magnification range.

Total magnification used can be calculated by multiplying the eyepiece magnification by the zoom magnification and objective lens magnification.

The working distance varies from 165mm (when using a 0.5X objective lens) to 30mm (when a 2X objective lens is used). Normal working distance for the standard configuration (1X objective lens) is 100mm.

Mounting a camera to the trinocular head

The trinocular S7 versions allow you to add a camera attachment to photograph or take video of your samples. Screw the C-Mount adapter into the dedicated port on the trinocular head, then insert the microscope camera into the C-Mount adapter. Note: The C-Mount adapter that comes with the S7-T models is designed to fit with Swiftcams. Other microscope cameras may require a different kind of adapter.

VI. Maintenance and repair

Cleaning

Keep all lenses clean. Fine dust on the surface of the lens should be gently blown off with an air canister or wiped off with a soft lens cloth or lens tissue. Stubborn fingerprint smudges or oil marks can be wiped off with lens tissue moistened with a small amount of xylene or a 3:7 mixture of alcohol and ether. Never use organic solutions to clean any other surface (especially the plastic surfaces). If necessary, please choose a mild detergent.

Storage

After use, cover the microscope with the dust cover provided and store it in a dry and clean place free from moisture to prevent rust. Remove the eyepieces when not in use, and place covers on the eyepiece holders.

Repair

Do not attempt repairs on your own, particularly on the optical parts. Contact a Swift Optical representative through our customer service email or phone line with any issues.

VII. Troubleshooting

If you have a problem, you may be able to correct it yourself. Here are some common issues and easy solutions you can try before calling customer support for service.

*Caution: Never disassemble the electrical, mechanical, or optical components. This servicing should only be done by a Swift technician.

Issue	Possible cause	Solution
Cannot slide eyepiece into microscope tube	The eyepiece locking screw in tube have not been loosen	Loose the locking screw and tighten them once eyepiece is installed
Double images	Interpupillary distance is not correct	Readjust the eyepieces
	Diopter adjustment is not correct	Readjust the diopter rings
	Magnification of each eyepiece is not the same	Mount eyepieces of the same magnification
Dirt appears in the field of view	Dirt on the specimen	Clean the specimen
	Dirt on the surfaces of eyepiece	Clean the surfaces

Image is blurry	Objective surfaces are dirty	Clean the objective
	Diopter adjustment is not correct	Readjust the diopter
	Focus is incorrect	Readjust the focus
The focusing knob is not smooth	The focusing knob is too tight	Loosen it to a suitable position
Head keeps slipping down	The focusing knob is too loose	Tighten it to a suitable position
Eyes fatigue easily	Diopter adjustment is not correct	Adjust the diopter rings
	Light is too bright	Dim the brightness
Ring light does not work when the switch is on	No power supply	Check the connection with the power supply

VIII. Warranty information and customer support

Our microscopes are manufactured to meet ISO 9001 standards. Swift warranties are as follows:

- Five (5) Year Warranty for Microscopes: Microscopes come with a five (5) year warranty against manufacturing defects. Does not cover normal wear, routine maintenance, add-on accessories, damage resulting from repair by unauthorized parties, accident, alteration, shipping, misuse or abuse is not covered.
- One (1) Year Warranty for Electrical and Video components. Does not cover light bulbs, batteries, fuses, or electrical cords.

All warranties start from the original date of purchase. Swift provides the repair or replacement of warranted parts for free, including labor, during the warranty period.

Proof of original purchase is required. Buyers are responsible for shipping to and from our warehouse for warranty services. The warranty does not cover damages resulting from normal wear and tear, abuse, or unauthorized repairs.

*For customers living outside the United States, Swift Optical Instruments, Inc. will provide standard warranty service. Both inbound and outbound shipping costs (including duties and taxes) is the responsibility of the consumer.

For more information or to submit a repair request, please contact our Customer Support department:

North America

Tel: (+1) 877-967-9438, option 1 (USA)

Email: customersupport@swiftoptical.com

Europe

Tel: (+44) 208-638-8819 (UK)

Email: customersupport@swiftoptical.com

*In order to serve Europe customers efficiently, we recommend to call the hotline during working hours 8 AM – 4 PM (London Time).

IX. Manual and software downloads

Please visit www.swiftoptical.com for online download of instruction manuals and relevant software (Manuals are downloadable in the product details page under “Swift Basics” products and Software are downloadable under “Support” menu).

Disclaimer: We are constantly working to improve our instruments and to adapt them in response to customer feedback. These improvements occasionally involve small modifications to the mechanical structure and optical design of our microscopes. Therefore, some descriptions, illustrations, and specifications in this instruction manual may vary slightly from the microscope you receive.

Swift Optical Instruments, Inc.

(877) 967-9438

www.swiftoptical.com