

## Quick Installation Guide – LR-2000 & LR-2000HiLoMA Readers and Tags

**If you are new to the LR-2000 and LR-2000HiLoMA readers, or if this is your first long-range installation, and you are having any concerns, we suggest that you call AWID Technical Support at +1-408-825-1100.**

The LR-2000-series Readers are long-range Radio Frequency Identification readers that use AWID’s encoded vehicle-mounted tags and hand-held cards. This Guide describes the Wiegand interface. For RS-232 interface, see AWID’s Technical Reference.

*Before you start the installation, download and study the LR-2000 Installation & Operation Manual.*

### Preparation

- **Layout Plan:** Ideal conditions for the installation site are –
  - ▶ 1 car length between reader and gate;
  - ▶ Vehicles driving in the lane that is nearest the reader, in a straight line, at up to 15 miles per hour;
  - ▶ Reader mounted on a bracket with pan-and-tilt-adjustable head for aiming the reader;
  - ▶ Reader location and height to match vehicle and tag types;
  - ▶ Reader and tags aimed toward each other, and parallel, when tags are 15 foot from the reader (the “sweet spot”);
  - ▶ Good tag location in vehicles determined by tests before attaching the tags; and
  - ▶ Using the LR-2000HiLoMA reader set if the lane turns at the “sweet spot”, or if vehicles are both big trucks and small cars.
- **Power Supply:** A separate dedicated DC power supply for each LR-2000 reader or “HiLo” reader set, connected to nothing else. For a 12-14 volt DC supply, rating = 1.5 amperes or more, linear, regulated supply. Locate 12 feet or more from the reader.
- **Housing:** Mount the reader inside a Lexan housing if the reader is mounted outdoors *and* is exposed directly to rain or snow, or to bright sunlight in a hot environment. Example: The Housing Company, Model PCH196 (14 inches by 14 inches by 3 inches).
- **Cable:** May be separate cables for data and for power, or may be combined for data and power together. Max. length = 500 feet. For *power* alone – 18 gauge, 2 conductors, stranded wires, color-coded, overall 100% shielded, high quality. For *data* alone – 22 gauge, 3 conductors, stranded wires, color-coded, not twisted pairs, overall 100% shielded, high quality. For *combined* cable – 18 gauge, 5 conductors, stranded wires, color-coded, not twisted pairs, overall 100% shielded, high quality.
- **Mounting:** Adjustable pan-and-tilt brackets (Pt.No. LR-MB-0-0) in most installations, to aim the readers at the tags for reading.

### Pre-Installation Testing *(See Quick Installation Guide for LR-2000KIT Installation Kit)*

- *Before* installing at the site, run these tests on the bench at your shop, or in your van at the site – almost anywhere.
  1. Installation Kit (Pt.No. LR-2000KIT-0-0): Provides beep and LED color. No need to mount the reader or interface to the system.
  2. Connections: Connect together the 3 negatives (black wires) on the reader, test unit, and power supply, plus reader’s yellow wire. Connect together the reader’s orange wire to the test unit’s orange wire. Connect together the 3 positive power lines (red wires) on the reader, test unit, and power supply. See Figure 1 for test wiring.
  3. Holding test tags: Squeeze in fingertips at edge of tag. Hold tag at arm’s length to your side. Tag and reader facing each other.
  4. Procedure: When the test unit’s LED shows red, present one of the test tags from the Kit to the reader. Measure (a) the maximum distance “R” where reads occur, and (b) the width “W” of the effective RF field at half of maximum reading distance.
  5. Results: Tags should read about 3 reads per second, inside the “balloon” (Figure 2). All tags should read to 15 feet or more.

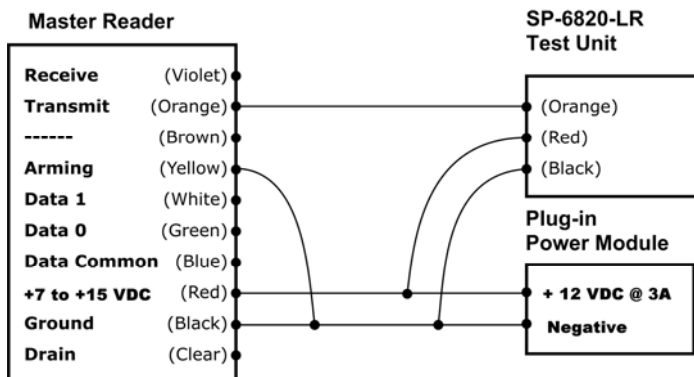

Figure 1. Connections for Pre-Installation Testing

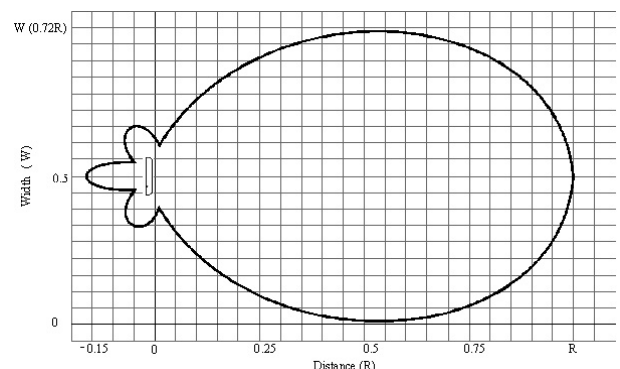

Figure 2. Effective RF Field for LR-2000 Reader

## Mounting the Reader and the Remote Antenna (See LR-2000 Installation & Operation Manual, Sections 5, 8 and 9)

1. Fasten the mounting bracket to the pole, post, pedestal, wall or beam. Leave space for the reader unit's pan-and-tilt adjustment.
2. Fasten the reader to the bracket with 2 ¼"-20 screws. The LR-MB bracket includes fasteners. With a housing, use longer screws.
3. Cut off the connector from the reader's cable. For LR-2000HiLoMA, locate the 6 foot coaxial cable that will connect the 2 units.
4. Aim the reader (and "HiLo" antenna) toward the location of tags when they are mounted on vehicles, at the "sweet spot" distance.

## Wiring the Reader (for Wiegand Interface) (Study Figure 3 carefully)

1. Check the power supply and cable(s) for power and data to be certain that they meet AWID's specifications ("Preparation", p. 1).
2. Connect the wires -- *yellow to black* at the reader; *black and red* to the power supply; *green and white and blue* to the controller.
3. Connect the reader's *drain* (bare silver) wire to the shields of all cables. **Do not ground** drain and shield wires – they must float.
4. Keep the reader's *orange* wire available for connecting the LR-2000KIT's test unit. Tape off *violet* and *brown* wires separately.
5. For LR-2000HiLoMA, screw the coaxial cable's rings to the brass connectors on the reader and the antenna. Seal the connectors.
6. Do not tape or bead the wire junctions until the complete system has been tested thoroughly. Keep all junctions accessible.
7. Test the reader (and antenna) using the LR-2000KIT Test Kit. The hand-held test tags should read on the test unit at 15 feet.

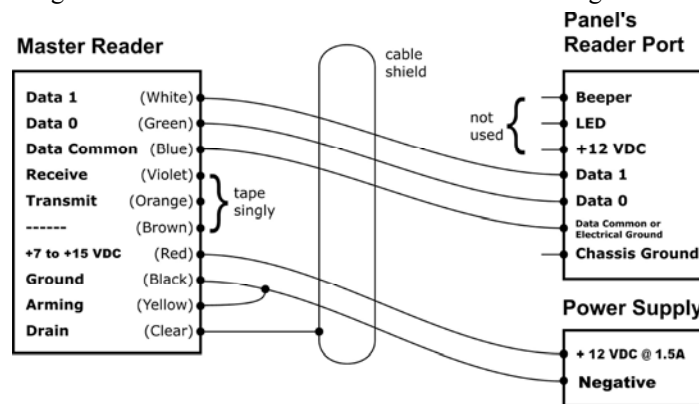

Figure 3. Wiring the Complete System for Wiegand Interface

## Using Tags and Cards

- Select a location for the tags that has clear line-of-sight between the tags and the reader. Tags should be about parallel to the face of the reader at the reading distance (the "sweet spot" – 15 feet). Test the tags with both "landscape" and "portrait" orientation.

**VT-UHF Visor Tag:** Clip the tag on the sun visor. At about 15 feet, the driver lowers the visor so the tag faces the reader.

**HT-UHF Hangtag:** Hang the tag on the inside rearview mirror's post. Or hold the tag, by fingertips at its hook, inside the vehicle.

**RV-UHF Mirror Tag:** Using the tag's adhesive, press the tag smoothly on the frame of the inside mirror, facing the reader.

**WS-UHF Windshield Tag:** Using the tag's adhesive, press the tag firmly inside the glass, at least 2 inches from edge of windshield.

**MT-UHF Metal-Mount Tag:** Fasten tag outside or inside the vehicle, using screws, pop-rivets, Velcro dots, or the tag's adhesive.

**CS-UHF Clamshell Card and GR-UHF Graphics Card:** Hold facing reader with fingers at edge of card. (Read on UA-612 also.)

## Programming the System

1. Complete the LR-2000 reader's (or "HiLo" master reader's) interface to the host access control or vehicle identification system.
2. Program the applications system for the type of reader, and for the tags' code format, facility (or site) code, and card numbers.
3. Assign suitable programming for the individual tags in the cardholders' database – gate groups, time zones, priority levels, etc.
4. Program the applications for the action to be taken for each valid read – gate motor operation, data recording, reports generation.

## Testing the Completed System

1. Drive a vehicle with a mounted tag into the read range on the lane. Observe the code registered by the system for accuracy.
2. Test operation of all functions by driving a vehicle with an authorized tag code past the reader and through the gate repeatedly.
3. Study the PC monitor's data display for full and correct information about events on the system. Watch for "Access granted".
4. Enter the command for a report of events in the system – for individual vehicles in a time period and for history at a single gate.

## If a Problem Occurs

1. Use the LR-2000KIT Installation Kit to measure performance of the reader with hand-held test tags. Isolate the problem.
2. Study the LR-2000 Installation Manual, Part C – Trouble-Shooting, for an organized way to identify a problem source.
3. Visit AWID's web site ([www.awid.com](http://www.awid.com)) for product data and downloads. For technical support questions visit ... [www.awid.com/support](http://www.awid.com/support) or call +1-800-369-5533 (in the U.S.) or +1-408-825-1100 from 8:00 a.m. to 5:00 p.m. Pacific Time.