

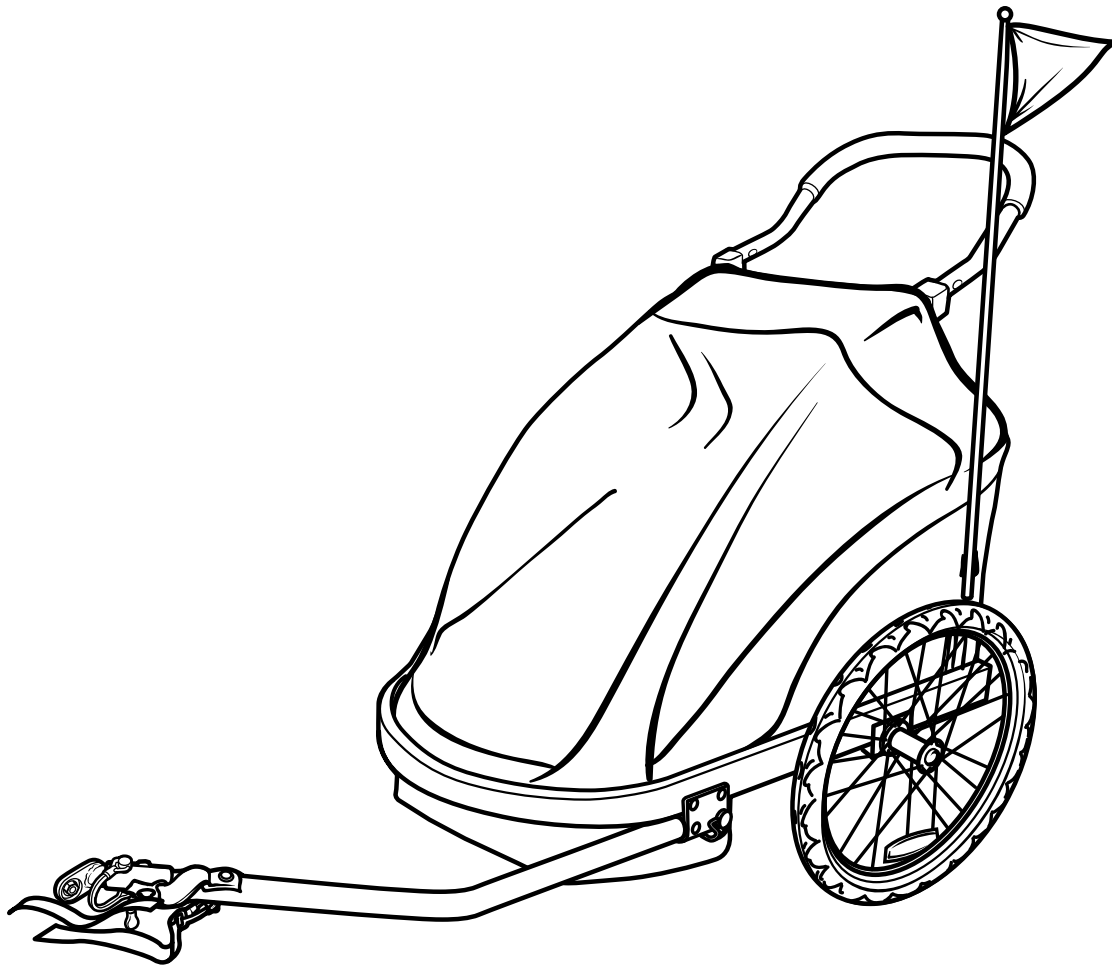

Owner's Instructions and Safety Manual



Traveler
Bike Trailer

Contents

1. Trailer Components
2. Assembling Your Trailer
3. Attaching the Tow Arm
4. Attaching the Trailer to a Bike
5. Configuring the Trailer into a Jogger
6. Attaching the Jogger Fork Tubes
7. Attaching the Jogger Wheel
8. Attaching the Safety Flag
9. Using the Cover and Windscreen
10. Using the Brake
11. Securing Children and Cargo
12. Disassembly, Folding and Storage
13. Securing and Removing Children and Cargo
14. Maintenance, Storage and Customer Service
15. Safety Warnings

Caution!

Biking and bicycle touring are increasingly popular recreational activities. Your new trailer is designed and constructed to provide a portable, comfortable and sturdy addition to your outdoor ventures. Please read the instruction manual and all safety warnings closely before using your trailer and keep manuals for future use. For questions or additional information please visit **www.everdaybicycles.com** or email us at **service@smspdi.com**

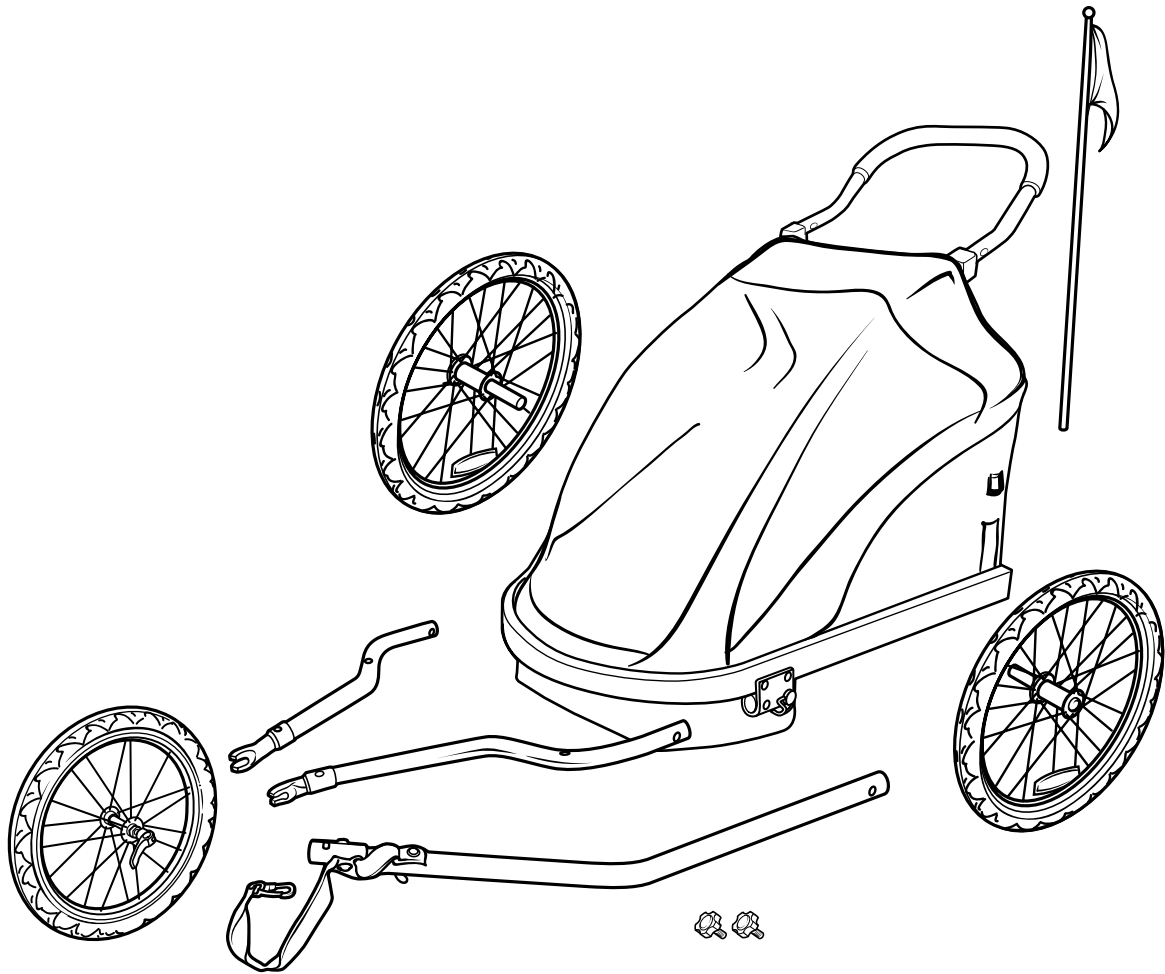

Package Contents:

Trailer body, 2 rear wheels, tow bar with hitch connector, jogger wheel (select models only), 2 jogger fork arms (select models only), 2 fork arm screw mounts (select models only), flag, manual

Required Tools:

10mm wrench (for attaching to non quick release bicycles only)

Trailer Mode

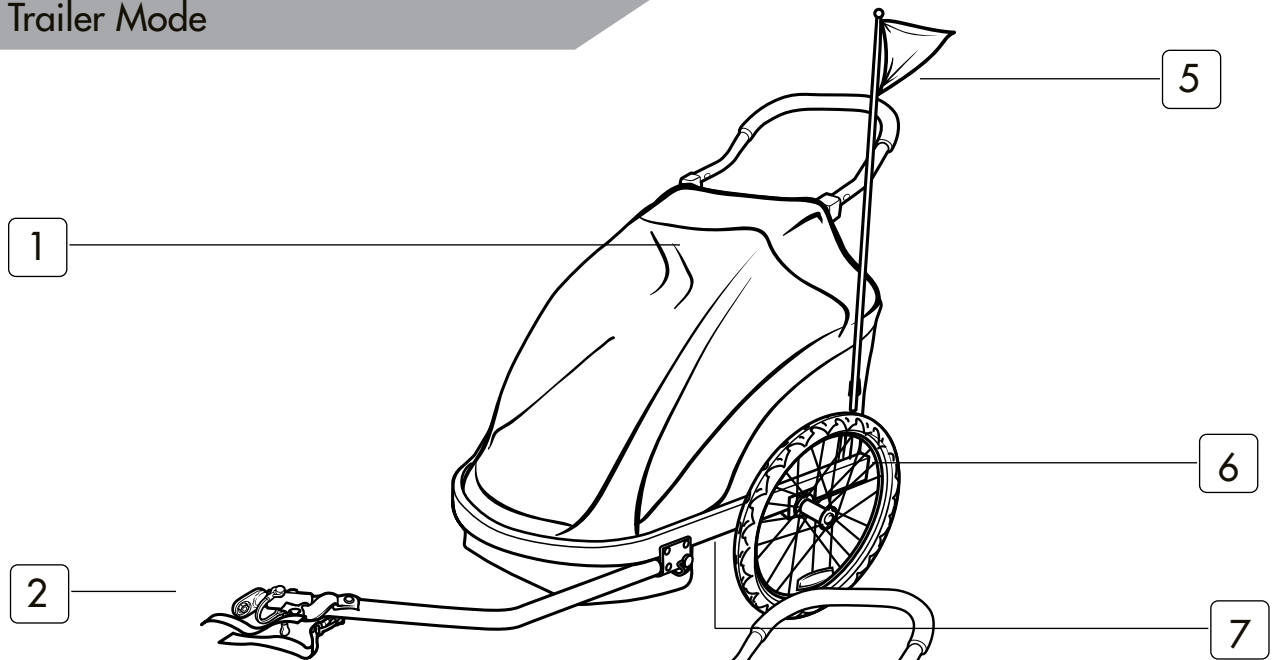

Jogger Mode (select models only)

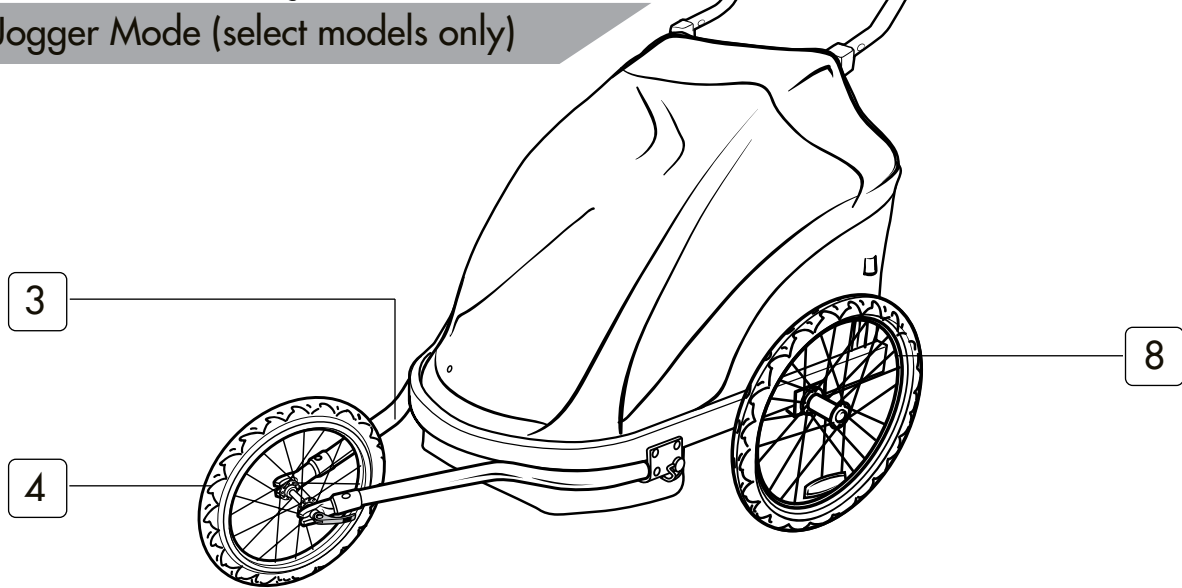

Trailer Components

1. All weather/mesh access panel
2. Tow bar and hitch connector
3. Jogger fork arm (not included with all models)
4. Jogger wheel (not included with all models)
5. Push bar/folding assembly
6. Push button release wheels
7. Tow bar/jogger fork receiver
8. Rear brake straps

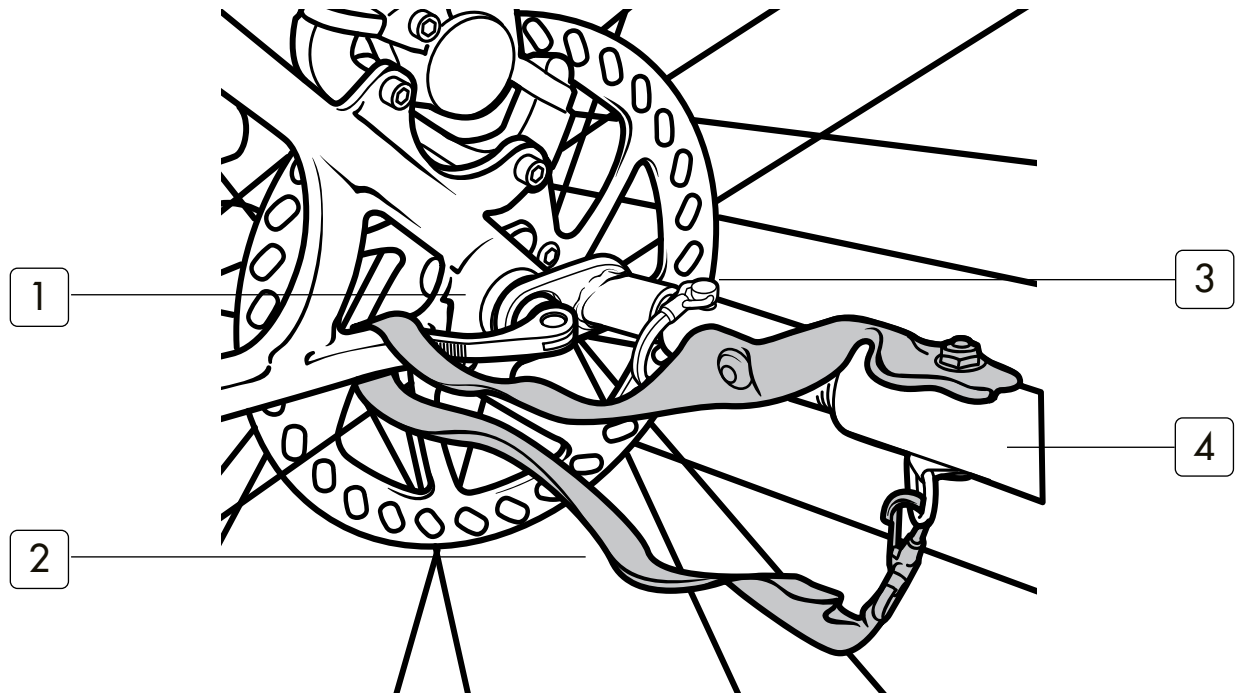

Tow Bar and Hitch Connector Components

1. Hitch connector
2. Safety strap
3. Lock pin
4. Tow bar

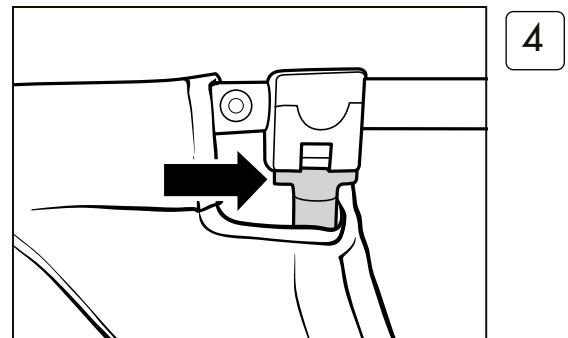
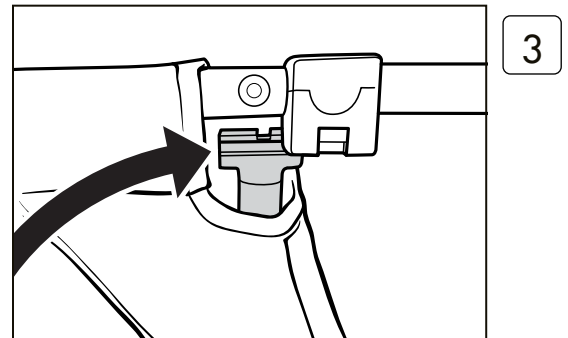
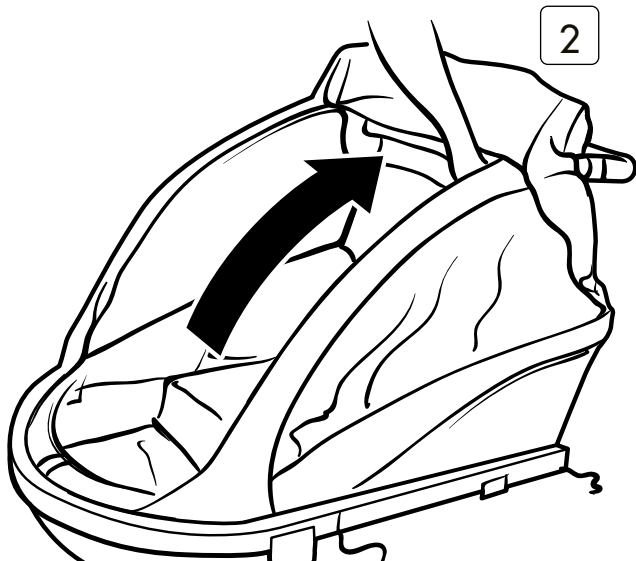
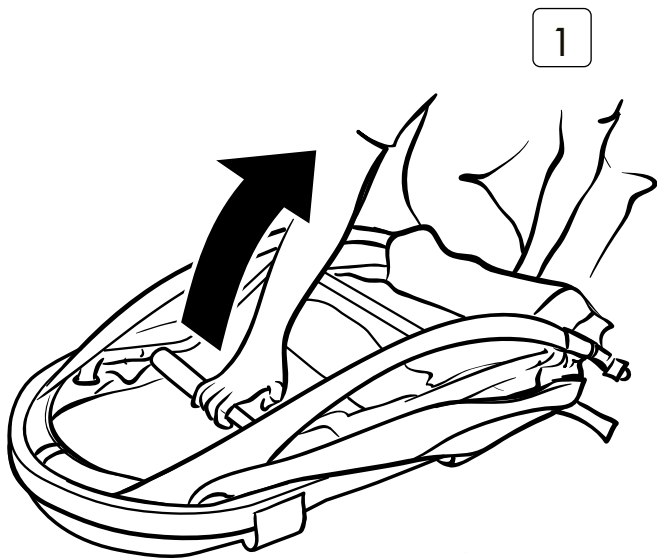

Assembling your Trailer

1. Remove the trailer parts from the box. Set the main trailer body flat on the ground with the black side down.
2. To open the frame, lift the rear cabin tubing up, then the front tubing. Pull the rear cabin tubing up to allow the black clip on the front cabin tubing to lock into the hardware on the rear cabin tubing. Note this may require some initial force.
3. Once located, push the two pieces of hardware together to until they audibly “click” into position.

WARNING! Immediately discard of all plastic bags and plastic wrapping materials.

Using Lock Pin & Spring Clip Fasteners

To use the lock pin and spring clip fasteners, insert the pin at attachment point until it pushes through the opposite hole. Rotate the spring clip up and over until it snaps into place over the pin head. To unlock, reverse order.

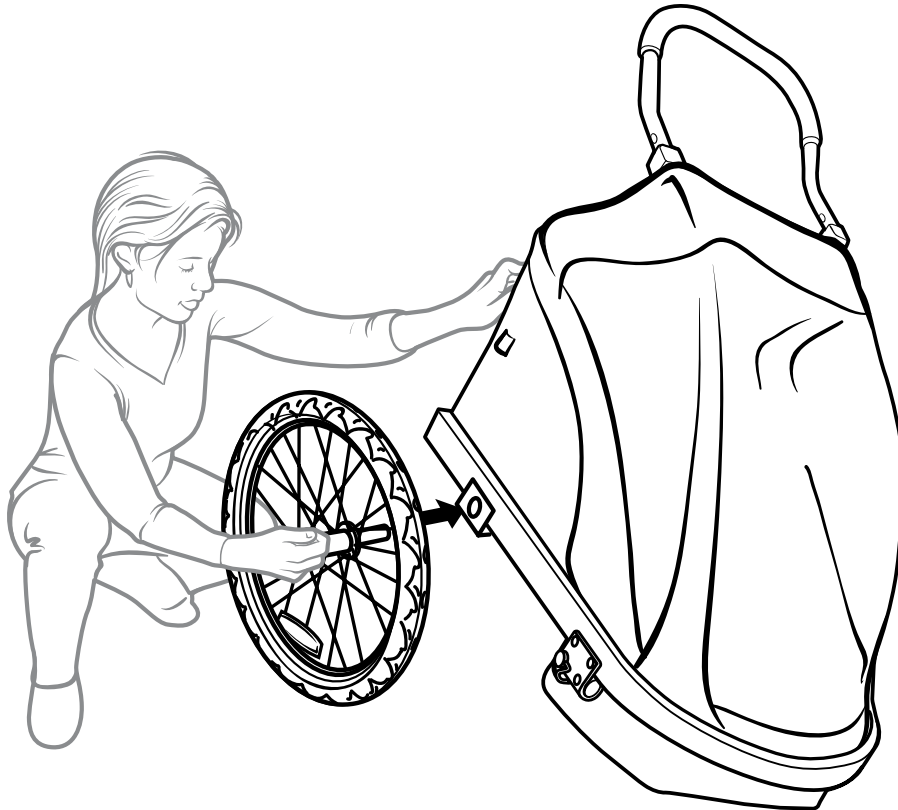
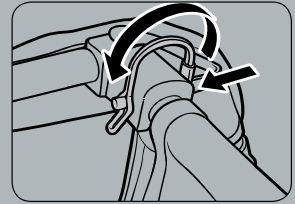

Attaching the Wheels

1. Insert the wheel axle into the axle receiver on the trailer body
2. Lock the wheel axle onto the frame by inserting the pin into hole on the wheel axle and locking the pin securely. Pull firmly on the wheel to confirm the axle is fully secure.

WARNING! You must make certain the frame and wheels are locked before using the trailer. Failure to do so could result in serious injury to you or your child. Make sure the cabin assembly is securely locked together in place before use.

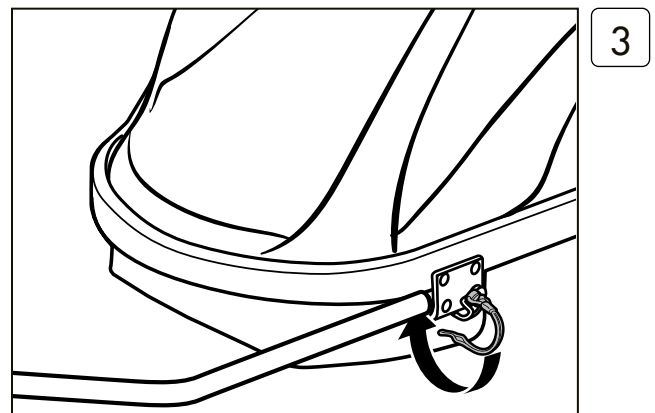
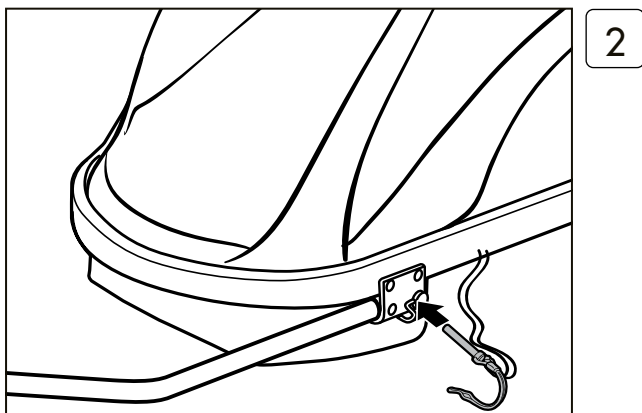
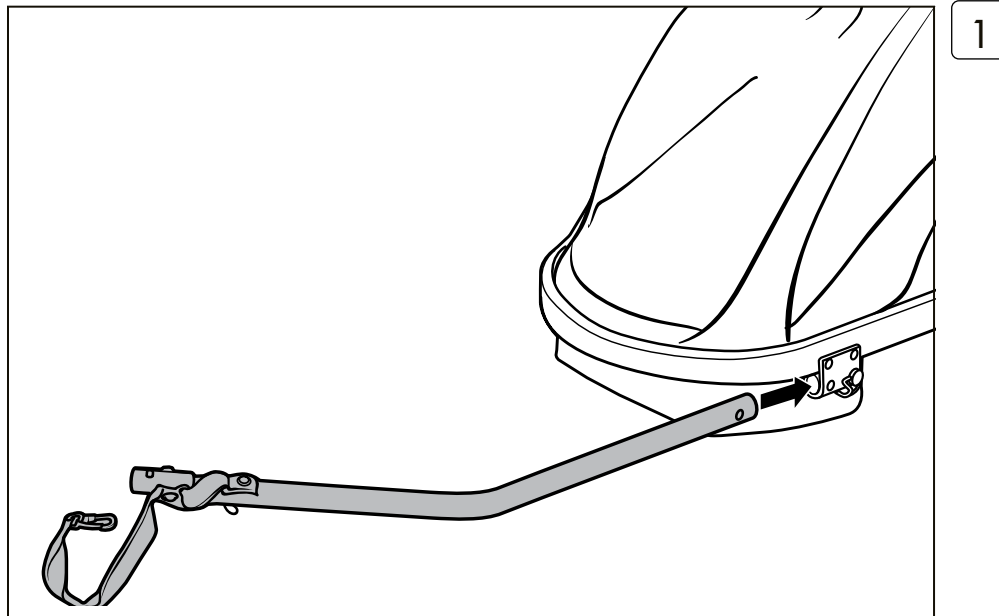

Attaching the Tow Arm (for use as a trailer)

1. The hitch arm is held in place by a spring pin and a quick release pin. Depress the spring pin and slide the tow arm into the receiver on the left side of the trailer as shown.
2. Once the spring pin locks in place in the hole in the bracket, locate the quick release pin, (tethered on the trailer frame), then insert the pin through the bracket and into the hole in the tow arm. The pin should go completely through the tow arm and bracket. Once the pin is through, flip the safety clasp over and onto the pin. Give the pin a tug to be sure it is secure.

WARNING! Check this pin periodically during and before each use to be sure it has not become loose. Failure to do so could result in serious injury to you or your child.

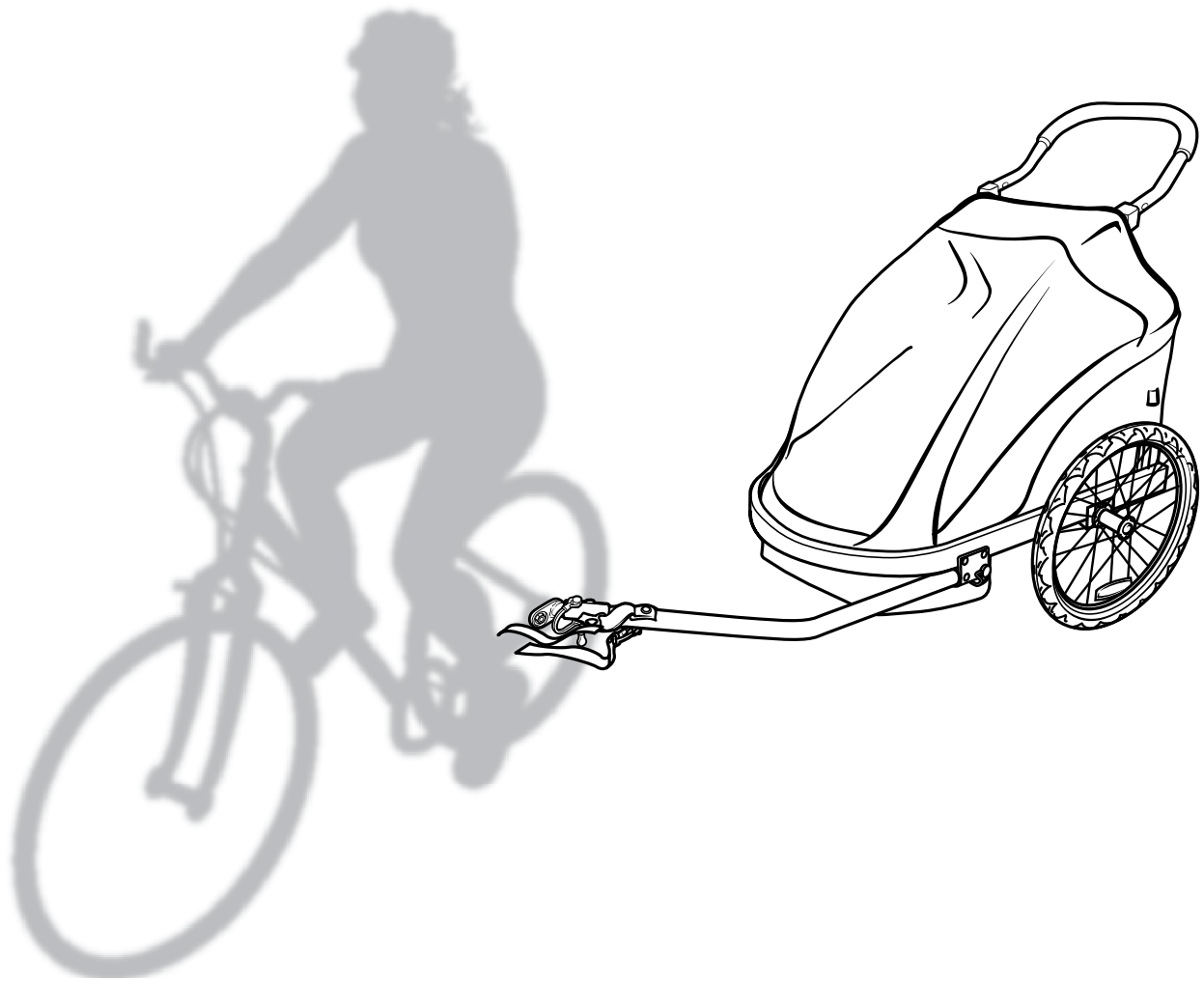

Attaching the Trailer to a Bike

Your trailer is designed to attach easily to just about any full-size bicycle. Once installed the hitch connector can be left on the bicycle and the trailer released using the spring clip.

The hitch fitting must be attached to the left rear axle of the bike. Do not attach to any cycle where it cannot attach to the axle. It is recommended that the bicycle(s) to which the trailer will be attached undergo a safety check by a qualified bicycle mechanic before attaching the trailer to it. This trailer is not designed to be used with electric bikes or motorcycles.

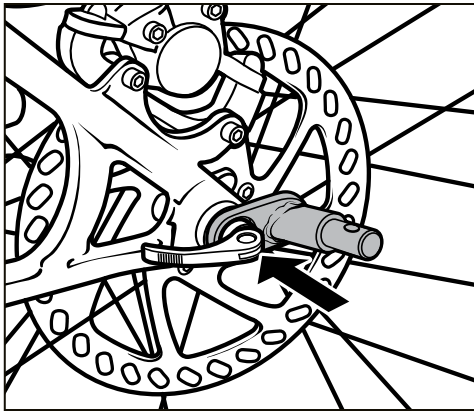

1

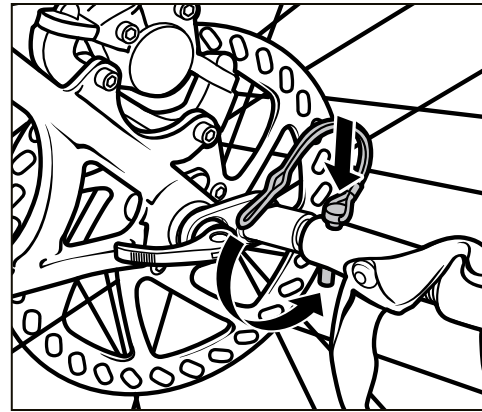

3

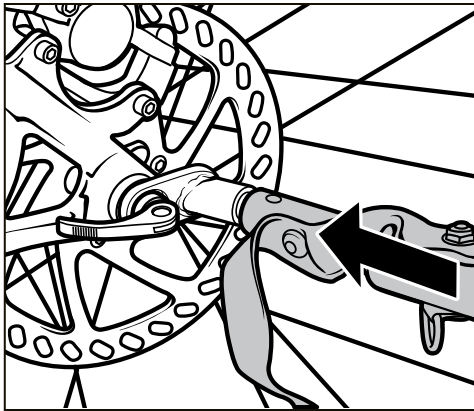

2

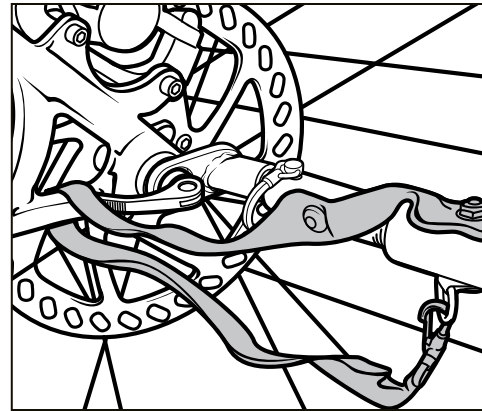

4

Attaching the Trailer to a Bike

1. Remove the quick release or nut from the left side of the bikes rear axle. Install the hitch connector between the quick release or nut and the bike frame. Tighten the quick release or nut according to the manufacturers recommendation.

2. Insert the flex connector onto the hitch connector. Insert the lock pin and close the spring clip. Wrap the safety strap around the frame of the bike and latch to the D-ring on the tow bar.

WARNING! Safety strap must attach to the bike frame when using this product in trailer mode.

Quick -release lock pin must be in place and locked before riding.

The height of the hitch clamp shall not exceed 15.7in (400mm) above the road surface and the standard drawbar load shall be between 30 and 80N.

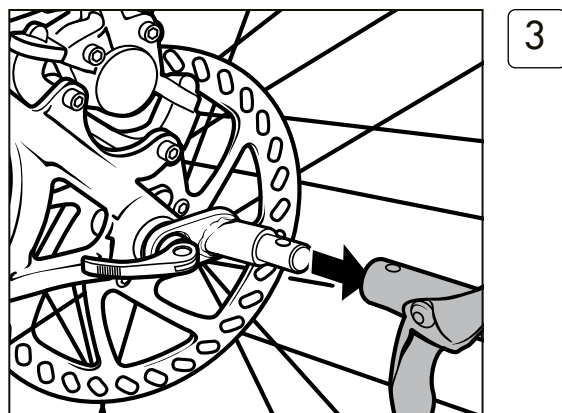
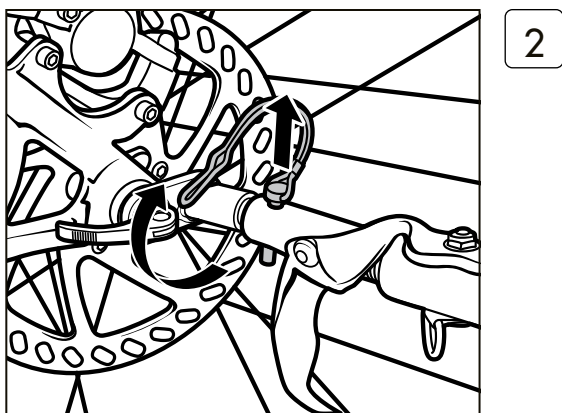
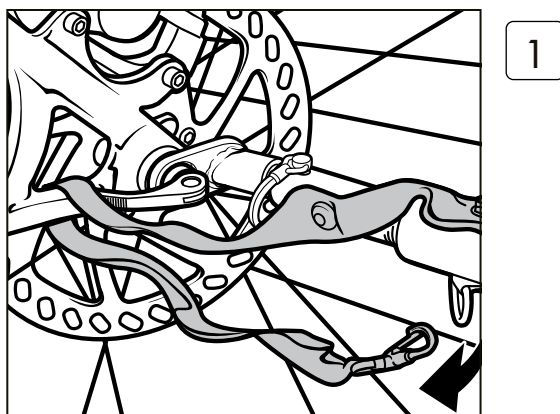

Removing the Trailer from the Bike

1. Remove the safety strap by releasing the clip on the D-ring. Remove the quick-release lock pin to release the flex connector and trailer. The hitch connector can remain on the bike when the trailer is removed.

Note: Additional hitch connectors for use on multiple bikes can be purchased at www.viavelobike.com.

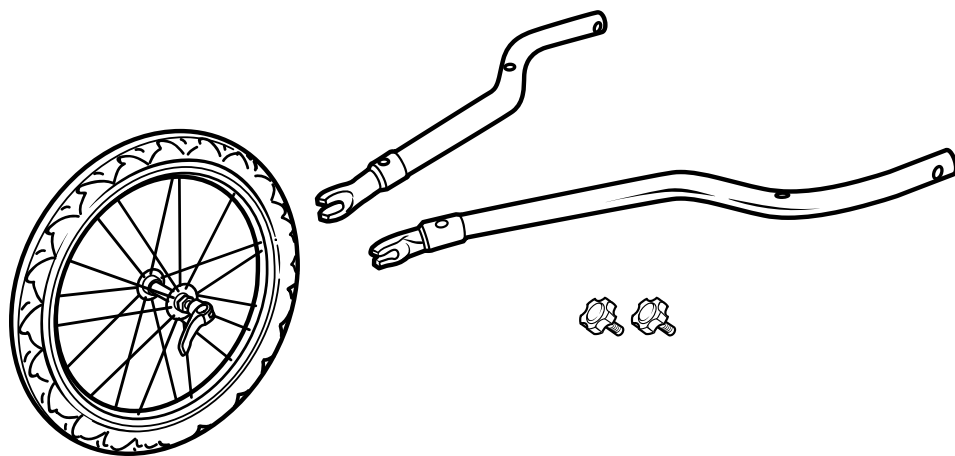

Configuring your Trailer into a Jogger (select models only)

Your trailer can accept an optional jogger kit.

Tow Bar and Hitch Connector Components

1. 2 fork tubes
2. 2 fixing screws
3. Quick release 16 inch wheel

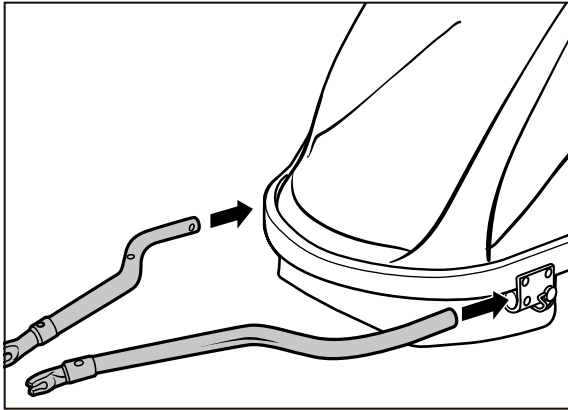

1

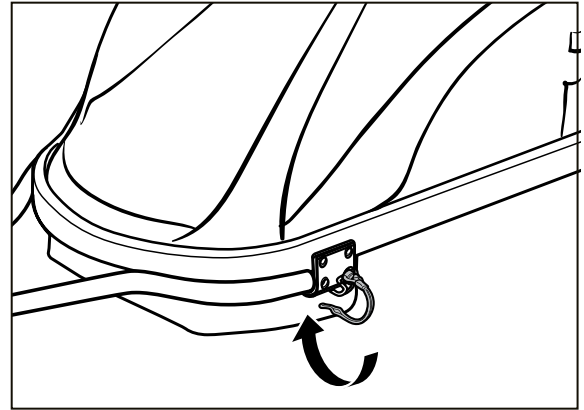

3

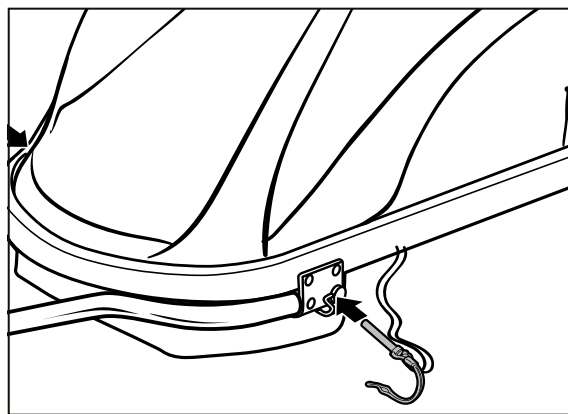

2

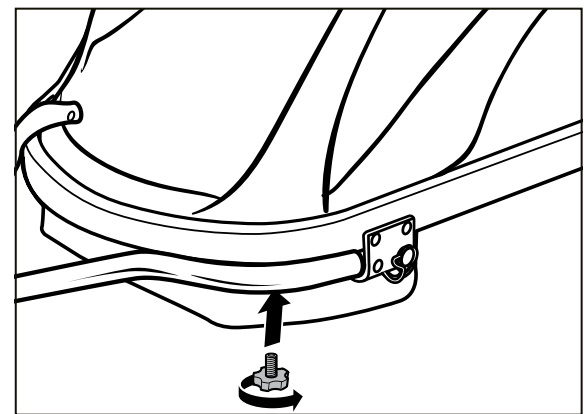

4

Attaching the Jogger Fork Tubes (select models only)

1. To install the jogger kit, first remove the tow arm by releasing the lock pin and then press the spring pin and pull out the arm.
2. Take one jogger fork tube and insert into the corresponding receiver on the trailer body and insert the lock pin and close the spring clip.
3. Tighten the fixing screw into the threaded nut in the bottom of the front frame tube. Perform same action for both fork tubes.

WARNING! Make sure spring pin is locked. If not locked, the pin may fall out, releasing the fork. This may cause injury to you or your child.

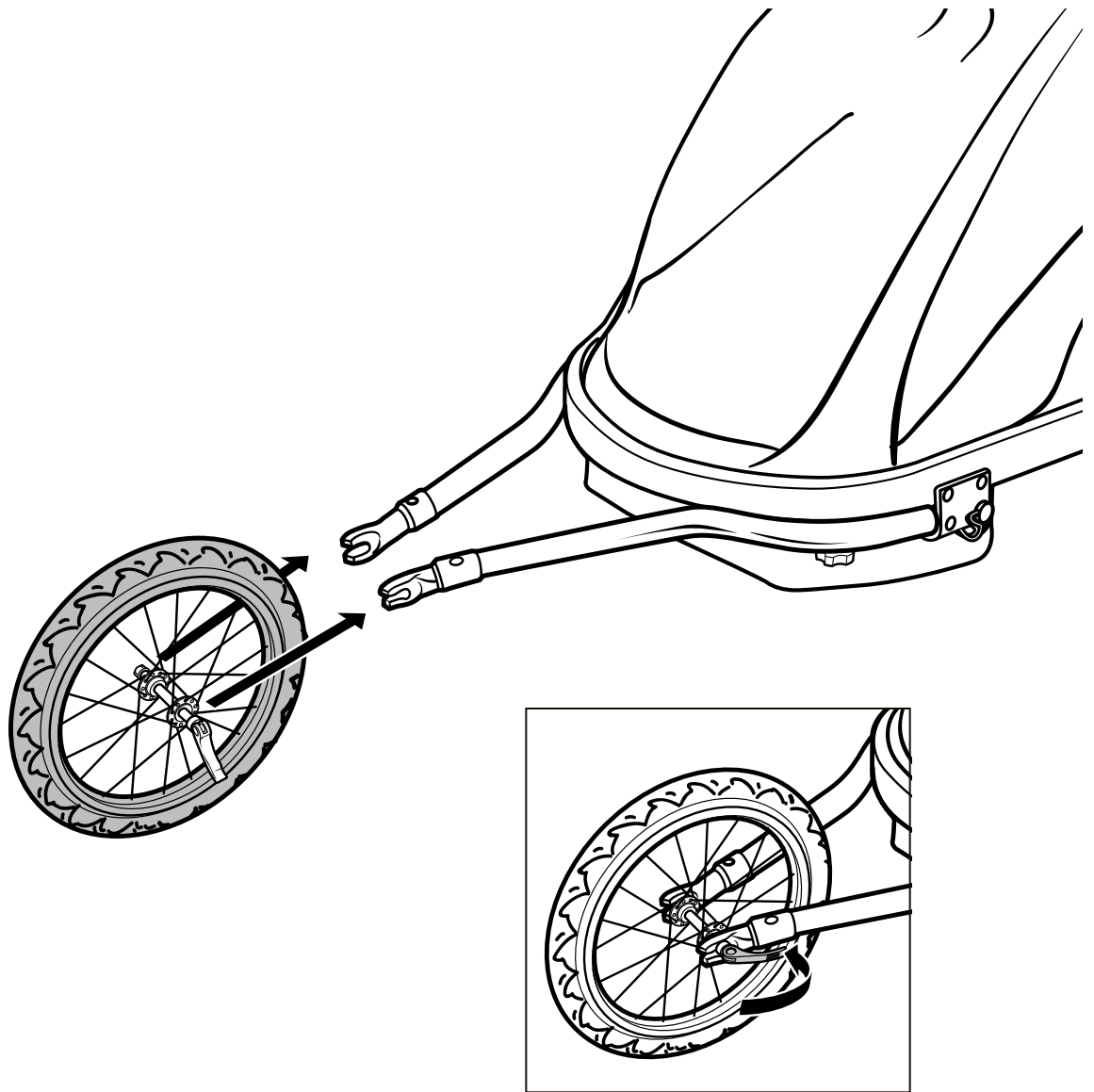

Attaching the Jogger Wheel (select models only)

1. Open the quick release axle skewer on the wheel to allow the axle to fit inside the plastic fork tips. Align the flats on the axle with the flats on the fork tips, and slide into the slots. Close the quick-release lever, making sure it is tight. If the wheel is still loose in the frame, open the release lever, tighten the thumb nut, and close the lever again. Repeat this until there is sufficient resistance to securely lock the wheel.

Note: If the wheel does not track straight, loosen the lever and shift the wheel slightly in the slot to adjust the direction, retighten and check the tracking.

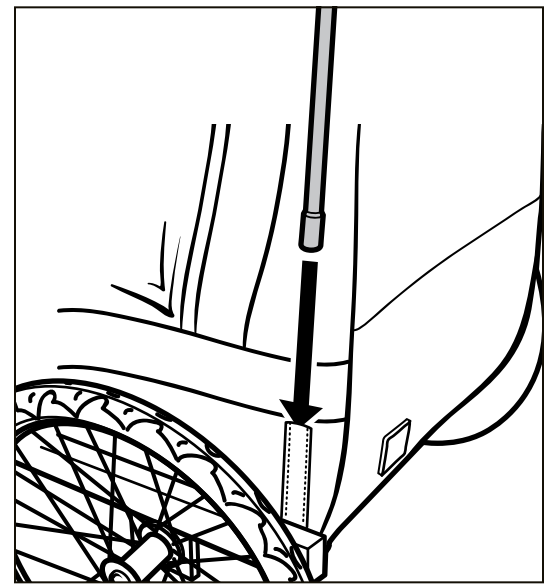
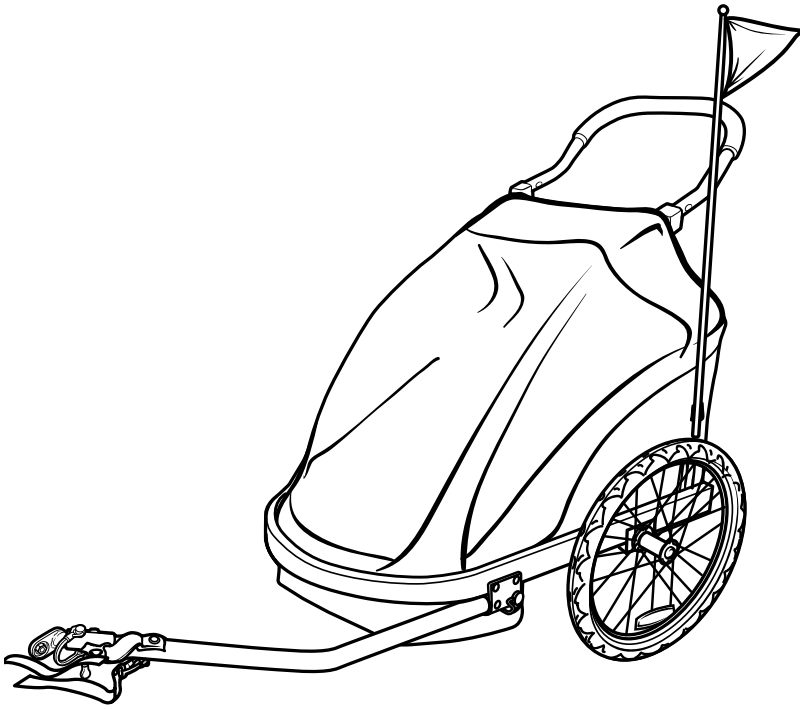

Attaching the Safety Flag

1. Assemble the flag and insert the end into the small sleeve on the left side of the trailer body.

WARNING! This flag is meant for use only with the trailer and greatly increases your visibility to others. This flag is not a toy. Do not let your child play with this flag when not in use. Failure to comply with this warning could result in serious injury to your child.

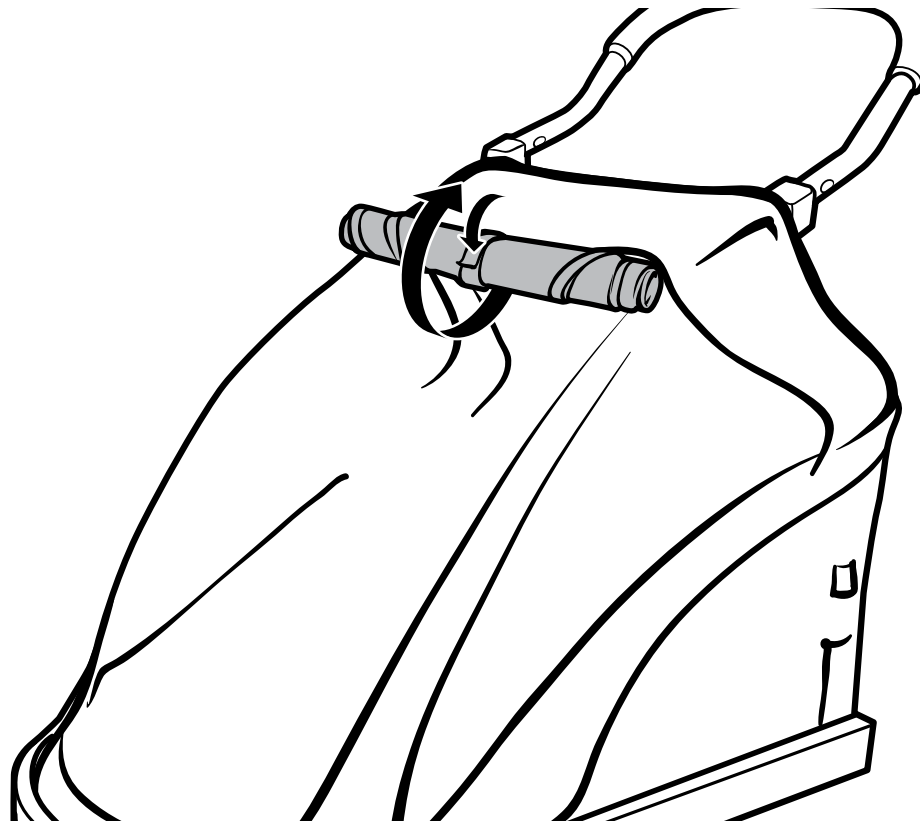

Using the Cover and Windscreen

1. The clear vinyl windscreen and the protective mesh barrier zip open for loading. In inclement weather, the clear windscreen protects your passengers from the elements. Weather permitting, you can roll up the clear window and affix with the elastic straps provided. The mesh allows ventilation, but prevents debris from entering the trailer.

WARNING! Rocks and debris from the bicycle wheels could injure your child. Never use the trailer without closing the mesh cover. Failure to do so could result in serious injury to your child.

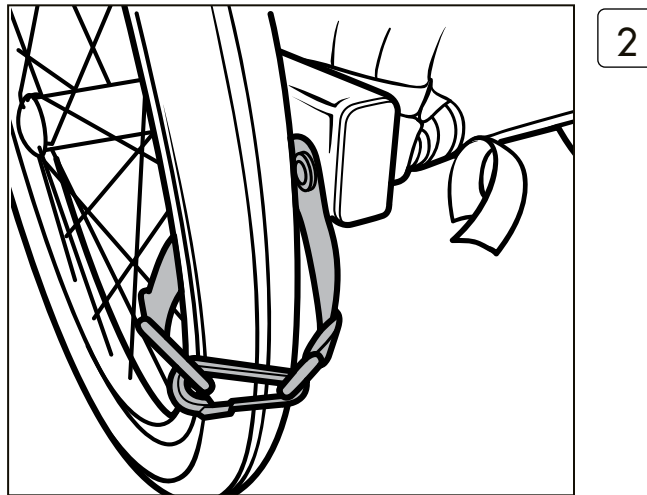
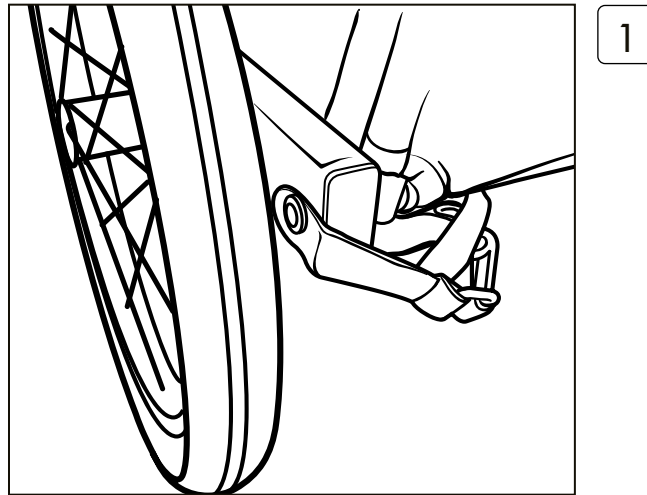

Using the Brake

Your trailer is equipped with a strap parking brake for added safety. When loading or unloading or parking your trailer, engage the parking brake to prevent the trailer from moving.

1. Release the buckle from the strap affixed to the rear of the trailer frame. Loop the free end of the strap through the spokes of the wheel, and clip the latch to the D-ring as shown.

WARNING! When releasing the brake, make sure to return the strap to the frame, and clip in place. Failure to do this will allow the strap to drag the ground, or it may become tangled in the wheel.

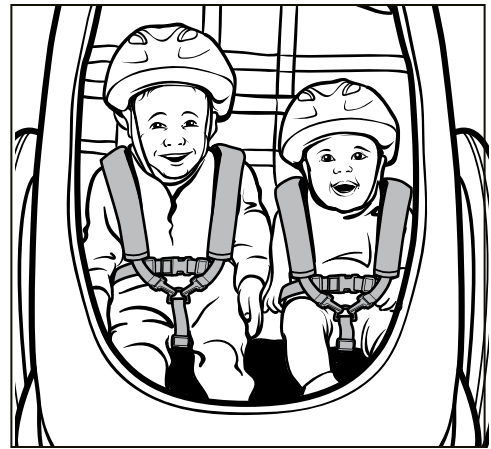
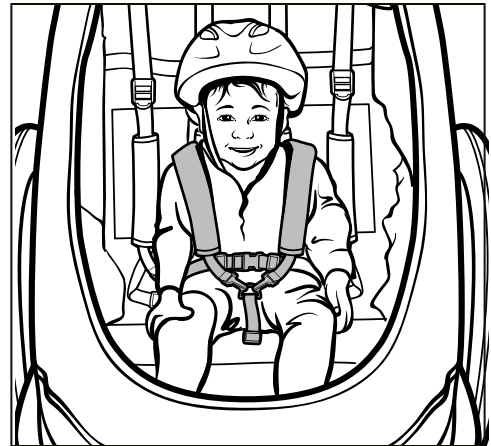
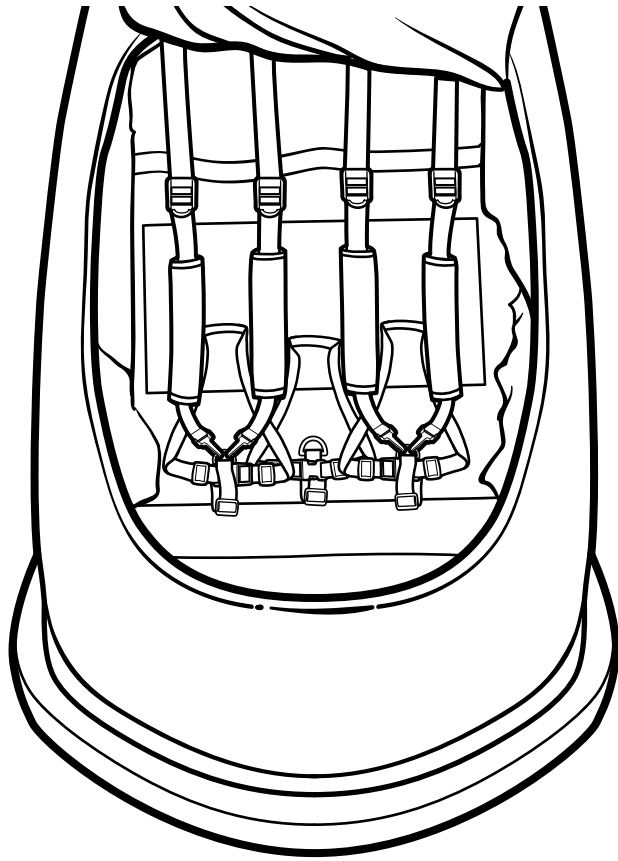

Securing Your Child

Place a single child in the center and use the center strap in the middle. For two children use the outer center straps and shoulder straps.

1. Un-clip the straps and place your child in the seat. Adjust the upper buckles to fit snugly above your child's shoulders. The crotch strap buckle should come just below your child's belly button, where a normal belt would lay. Adjust the ladder lock so the buckle is in the correct position.
2. Buckle the two side straps to the crotch strap and adjust snugly so you can fit average size fingers between belt and your child. The buckle should be centered in your child's abdomen. Hook the shoulder straps to the D-rings on the buckle and adjust the ladder locks so they fit snugly.

WARNING! To avoid serious injury or death from falling or sliding out, children should always wear the seat belt and shoulder straps. There should be a minimum distance of 1.5in (494mm) between the top of the child's head (without a helmet on) and the roof of the cabin. If the child's head protrudes above the upper crossbeam when seated, they are too tall to ride safely in the trailer.

1

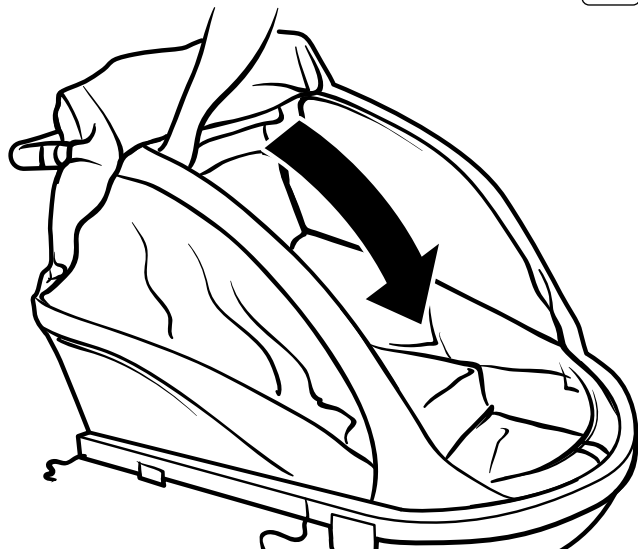

2



Cargo Storage

The trailer has a rear storage area. This is not intended for items weighing more than 10lbs (4.5kg).

WARNING! Distribute items carefully and evenly. Items may cause the trailer to become unstable. Failure to comply with this warning could result in serious injury to you or your child

Folding Your Trailer

To fold your trailer, simply locate the release latches on the vertical frame tubes. To operate the latches, first depress the red button, and then separate to open the frame. Push forward to fold. The trailer can be folded with or without the wheels on. If the wheels are removed, they can be stowed inside the trailer when not in use. To remove the wheels, simply disengage the lock pin, and pull the wheel out from the frame.

General Maintenance

From time to time, check your trailer for loose hardware, worn parts, torn material or stitching. Repair or replace parts as needed. Over or under inflation of tires may cause handling issues for the trailer. Replace tires only with street tread tires.

We suggest you periodically clean all parts, wipe dry and then let air dry, especially if exposed to salt water, salt spray, beach sand etc.

WARNING! Do not make any modifications to the trailer. Be sure that the trailer and bike are in good working conditions. A bike dealer can help you with inspection and maintenance. Do not use cleaning solvents. Clean only with mild soap and water.

Seasonal Storage of Your Trailer

Inspect the trailer and its parts before and after each use and storage. Check the working conditions of both trailer and bike before each use.

Store trailer in a dry area and always make sure trailer is dry before storing.

WARNING! To prevent color fading and eventual weakening of the fabrics or components, store the trailer out of direct sunlight.

Service and Repair of Your Trailer

Service and repair can be performed by any bike shop.

For any assembly questions or for replacement parts, PLEASE DO NOT RETURN TO THE STORE!

Call customer service by phone



855-249-1471

Email customer service at



service@smspdi.com

WARNINGS!

Please read the warnings carefully. Failure to follow these warnings and assembly instructions could result in serious injury or death.

- Passengers and riders must always wear properly fitted CPSC approved cycling helmets.
- Maximum weight capacity for one child is 50lb (23kg), and for two children is 100lb (45kg). Exceeding capacity may cause the trailer to become unstable.
- Not for use with children under 12 months or over 5 years of age or with an upper body height of 23.5in (595mm).
- Children must be able to hold up head with helmet on. Check with your pediatrician to make sure your child's development makes him or her a suitable passenger in this trailer.
- Do not carry more than two children. When pulling one child in the trailer, seat them in the center.
- Do not place more than 10lb (4.5kg) in storage compartment. Accessories or parcels placed in trailer may cause it to change balance and become unstable.
- Ride slower than you would if you were riding without the trailer.
- You will require extra stopping distance. Use your brakes early. Take corners very gradually.
- Do not exceed a speed over 13 kmph (8 mph) and reduce speed to 3mph (5kmph) when turning.
- Use on smooth roads only. Do not ride over curbs, potholes or off-road.
- Do not install a car seat or any other seating device to this trailer.
- Do not make any modifications to the trailer.
- Children must always fasten safety belts and wear bike helmets.
- Always instruct children NOT to rock, bounce, lean or extend limbs outside of the cabin.
- Install a rearview mirror on your bike to inspect children in the trailer while riding.
- Never leave children unattended in or around the trailer.
- Put on all brakes and fasten parking straps whenever you park the vehicle.
- Always use the flag supplied with the trailer to allow others to see you.
- Never allow children to assemble, fold, or disassemble this unit.
- Periodically re-check all fasteners to make sure they are tight.

Pre-Ride Safety Check

Before every ride the following safety check should be performed.

- Check to ensure hitch connector is tight.
- Check to ensure hitch safety strap is secure.
- BUCKLE UP! Check seat harness and secure all baggage.
- HELMETS ON! Ensure rider and child helmets are on and secure.
- Check TIRE AIR PRESSURE. Always maintain 20in wheels between 40 PSI and 65 PSI (2.7 BAR and 4.4 BAR) and 12in wheel between 30 PSI and 50 PSI (2.1 BAR and 3.5 BAR) or as indicated on tire sidewall.

General Safety Guidelines

SAFETY FIRST! Check the working conditions of both bike and trailer before each use. If you discover broken components, misalignments or missing parts, correct the problem prior to use. Please refer to all warning and guidelines for the proper use of this trailer. Be aware of what is necessary to safely control the bike-trailer combination. Follow these safety guidelines for safe and effective performance.

- Inspect the trailer and its parts before and after each use. Proper care and maintenance of the trailer are essential to safety.
- When assembling the trailer, make sure that the wheels are correctly and securely installed as described in the assembly instructions. Inflate the tires to the desired pressure and check the pressure before each use. Over-inflation may cause the trailer to bounce or turn over. Use only tires with street tread and not with BMX or knobby tread.
- Attach the hitch connector securely to the bicycle frame. The connector should be tightened and the safety strap wrapped around the stay or frame and the hook snapped into the D-ring.
- The person riding the towing bicycle should be at least 18 years of age and in good physical condition.

- Be sure that the bicycle used with the trailer is in good working condition and has good brakes. A bicycle shop can help you with inspection and maintenance. Please have your bicycle inspected by a qualified bicycle mechanic for compatibility.
- Riding at dusk or dawn with this trailer is not recommended. A reflector that complies with CPSC regulations must be mounted and visible on the rear and sides of the trailer.
- Be aware of exposure hazards such as wind-chill and heat exhaustion by less-active trailer passengers in prolonged exposure in colder temperatures, or by extended periods in warmer temperatures without adequate ventilation and hydration. Do not overload the trailer. The load limit for cargo and/or passengers is 100lb (45kg). Position the load as low as possible and center it within the trailer (front to rear and left to right). Any extra gear should be placed towards the rear. All loads should be secured so that it does not shift.
- Use extra caution when turning on uneven pavement, and going downhill.
- Do not ride over curbs. Avoid bumps and holes. Always signal your turns.
- Do not travel on the highways, busy streets or in areas unsafe for bicycling.
- Do not use trailer in snow or icy conditions.
- Do not travel or descend at high speeds.
- Do not allow any of the child's body, clothing, shoelaces, or toys to come in contact with moving parts.

IMPORTANT: Instruct children riding in the trailer not to bounce, rock or lean; such movements may cause the trailer to lean or flip. The tow-bar must not bear any extra load.

Do not attempt to install other seating systems in the trailer. It is not designed for car seats, stroller seats, infant beds, or any other type of seating. Use of any seating system other than the original equipment seat will void the warranty, and may result in damage to the trailer or injury of the passengers.

Pulling this trailer affects the operation of the bicycle. Stopping, starting and turning are affected, depending on the weight of the cargo. To familiarize yourself with the changes, load the trailer to capacity and practice in a safe area. Do not use your trailer until you have become accustomed to how it affects your bicycle handling.

SUFFOCATION WARNING: Plastic bags can be dangerous. To avoid danger of suffocation, keep plastic bags away from babies and children.

For more on Everyday lifestyle, please visit us at

www.everydaybicycles.com