



## CF700mm Telescope

### CAUTION:

Never attempt observing the sun with this telescope! Especially keep it in mind while the telescope is used by children! Observing the sun – even for a very short time – will cause blindness! Packing material (plastic bags, etc.) has to be kept out of reach of children!

#### **RISK to your child!**

Never look through this device directly at or near the sun. There is a risk of **BLINDING YOURSELF!**



Children should only use this device under supervision. Keep packaging materials (plastic bags, etc.) away from children. There is a risk of **SUFFOCATION!**

#### **Fire/Burning RISK!**

Never subject the device - especially the lenses - to direct sunlight. Light ray concentration can cause fires and/or burns.

#### **RISK of material damage!**

Never take the device apart. Please consult your Customer Service if there are any defects. The dealer will contact our service centre and send the device in for repair if needed.

Do not subject the device to temperatures exceeding 140 F.

#### **TIPS on cleaning**

Clean the lens (objective and eyepiece) only with a soft lint-free cloth (e.g. micro-fibre). Do not use excessive pressure - this may scratch the lens.

Dampen the cleaning cloth with a spectacle cleaning fluid and use it on very dirty lenses.

Protect the device against dirt and dust. Leave it to dry properly after use at room temperature. Then put the dust caps on and store the device in the original gift box.

#### **RESPECT Privacy!**

This device is meant for private use. Respect others' privacy – do not use the device to look into other people's house, for example.

#### **DISPOSAL**

Dispose of the packaging material/s as legally required. Consult the local authority on the matter if necessary.





# CF700mm Telescope



9

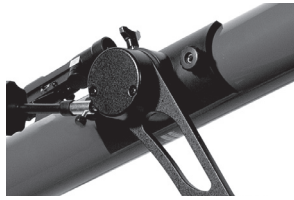

3



Fig 6

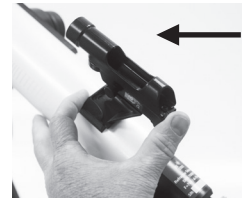

Fig 5



Fig 1

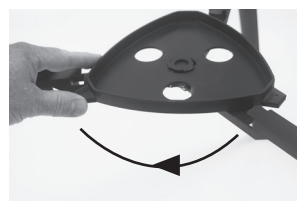

Fig 2



Fig 3



Fig 4

**WARNING:**

**Never use a telescope to look at the sun! Looking at or near the sun will cause instant and irreversible damage to your eye. Eye damage is often painless, so there is no warning to the observer that damage has occurred until it is too late. Do not point the telescope or its viewfinder at or near the sun. Do not look through the telescope or its viewfinder as it is moving. Children should always have adult supervision while observing.**

**Parts Listing**

Please check while unpacking, if all parts are complete:

1. Objective lens
2. Tripod with accessory tray
3. Telescope mounting arm with clamp
4. Telescope tube with dew shield
5. Red Dot Viewfinder
6. Plössl Eyepiece 26mm
7. Plössl Eyepiece 9.7mm
8. Diagonal mirror
9. Slow motion control cable
10. Tension knob azimuth (left and right)
11. Tension knob altitude (up and down)
12. Focuser
13. Azimuth Wheel
14. 2x Barlow

**Available Downloads:**

Instruction Manual, Planisphere, Software

**Visit:** <http://exploreone.com/pages/product-manuals>

**Setting Up**

It is recommended to do the first set-up during the daytime to familiarize yourself with steps and components of setting up your telescope. Now you may easily set up the telescope even in low light.

1. Spread the tripod legs until the tripod spreaders are level. Afterwards, put the accessory tray in place and lock it by turning by 60° **Fig 2**. Now you can set the tripod height by adjusting the single legs with their locking clamps **Fig 1**.
2. Insert the mounting arm from above into the mount hole at the tripod head and lock it with the black screw **Fig 3**.
3. Set the telescope tube with the threaded bolts from the left into the clamp so that the bolts fit into the clamp's holes. Then screw the black locking nuts and tighten them to a firm feel **Fig 4**.
4. Finally, put the Red Dot Viewfinder from the back in its holder **Fig 5**.
5. Slide diagonal into Focuser (turn silver screws until snug) and insert the 26mm Pössl eyepiece in to the diagonal (turn silver screws until snug).

**Aligning the Red Dot Viewfinder**

Your telescope is designed for terrestrial and astronomical observations. Please keep in mind that heat turbulences in the air are also magnified. In warm conditions, it can be useful to limit observations to medium magnifications.

First, remove the dust cover from the object lens.

**\*Please make sure to remove plastic insulator from battery Fig 6.\***

Insert the 26mm Plössl Eyepiece into the diagonal, you may now adjust the focus with the draw tube's wheel. The Redo Dot Viewfinder is activated by sliding the switch on its right side; there are two intensities available. Before the first observation, the viewfinder has to be aligned to the telescope. For this, point at a striking target (e.g. telephone pole) with the telescope's eyepiece. Now, without moving the telescope, switch on the viewfinder and adjust the red dot with the 2 adjustment screws (left and right - up and down) until it fits in the eyepiece's view. Now the viewfinder is aligned and ready to point for the telescope.

**Hint: Don't forget to switch off the viewfinder after use!**

**Using the Telescope**

Once you setup your telescope and aligned your viewfinder, you will now be ready to use your telescope. On the side and on top of the telescope mount head you will find tension knobs (#10) for the azimuth and (#11) for altitude. Loosen both knobs while holding the telescope near the focuser (#12). Slowly move the telescope close to the desired object to be observed and tighten the altitude and azimuth tension knobs. While viewing through your red dot, use both the slow motion altitude control and the side azimuth wheel (#13) for centering the desired object. Once centered you will be able to view through the eyepiece and make minor adjustments to the location using the altitude control and azimuth wheel.

**Hint: The object will appear as if it is moving in an elliptical path across the sky. You can make adjustments using the slow motion controls on the mount head.**

**Cleaning / Maintenance**

Your telescope should, like every optical instrument, be treated with care and stored dry. Doing so will maintain its optical performance for many years. After using, the dust cover should be closed after dew has dried off. The lenses can be cleaned with a soft brush available from photo stores. Don't ever use sharp detergents like gasoline or thinner to clean the optics!

The Red Dot Viewfinder is powered by a battery type CR-2032 (3V); if a replacement is necessary, remove cap (Fig. 1) by unscrewing set screw (Fig. 2) and sliding battery towards the front. Slide new battery in place with the positive (+) side showing. Replace cap and tighten with set screw (Fig. 2).

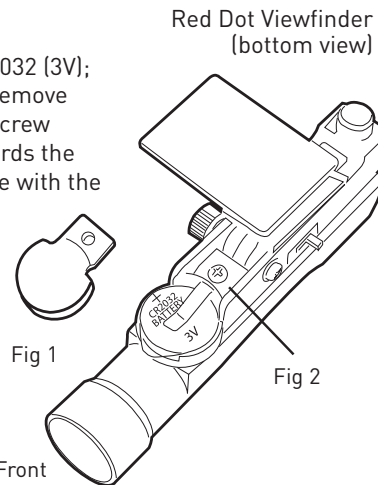

**Technical Data**

Objective Diameter: 70mm  
Focal Length: 700mm  
Focal Ratio: f/10  
Design: Achromatic

**Magnifications**

w/ Plössl eyepiece 26mm: 26.9x and with 2x Barlow: 52x  
w/ Plössl eyepiece 9.7mm: 72x and with 2x Barlow: 144x

**To make things simpler, please review the table with some magnifications:**

Telescope Focal Length	Focal Length of Eyepiece	Magnification	
		without 2x Barlow	with 2x Barlow
700mm	26mm	26.9x	52x
700mm	9.7mm	72x	144x

### Possible objects for observation:

We have compiled and explained a number of very interesting celestial bodies and star clusters for you but we suggest that you start practicing during the day focusing on terrestrial objects such as Birds and or Trees at varying distances from you. On the accompanying images at the end of the instruction manual, you can see how objects will appear in good viewing conditions through your telescope at varying powers (see pictorial examples below).

### Terrestrial Views

Please note the example picture of Mount Rushmore. Start with the 26mm Plössl eyepiece and focus until clear. After mastering the focus with the 26mm change the 9.7mm eyepiece and practice focusing and scanning until images become clear in the eyepiece. We have included some additional examples that are possible with your telescope such as a bird and a green on a golf course. **DO NOT POINT YOUR TELESCOPE DIRECTLY AT THE SUN OR BLINDNESS IS POSSIBLE.**

### The Moon

The moon is the Earth's only natural satellite.  
Diameter: 3,476km  
Distance: approx. 384,401km

The moon has been known to humans since prehistoric times. It is the second brightest object in the sky (after the sun). Because the moon circles the Earth once per month, the angle between the Earth, the moon and the sun is constantly changing; one sees this change in the phases of the moon. The time between two consecutive new moon phases is about 29.5 days (709 hours).

### Orion Nebula (M 42)

M 42 in the Orion constellation  
Right ascension: 05:32.9 (Hours: Minutes)  
Declination: -05:25 (Degrees: Minutes)  
Distance: 1,500 light years

With a distance of about 1500 light years, the Orion Nebula (Messier 42, abbreviation: M 42) is the brightest diffuse nebula in the sky – visible with the naked eye, and a rewarding object for telescopes in all sizes, from the smallest field glass to the largest earthbound observatories and the Hubble Space Telescope.

When talking about Orion, we're actually referring to the main part of a much larger cloud of hydrogen gas and dust, which spreads out with over 10 degrees over the half of the Orion constellation. The expanse of this enormous cloud stretches several hundred light years.

### Ring Nebula in Lyra constellation (M 57)

M 57 in the Lyra constellation  
Right ascension: 18:51.7 (Hours: Minutes)  
Declination: +32:58 (Degrees: Minutes)  
Distance: 2,000 light years

The famous Ring Nebula M 57 in the constellation of Lyra is often viewed as the prototype of a planetary nebula; it is one of the magnificent features of the Northern Hemisphere's summer sky. Recent studies have shown that it is probably comprised of a ring (torus) of brightly shining material that surrounds the central star (only visible with larger telescopes), and not of a gas structure in the form of a sphere or an ellipsis. If you were to look at the Ring Nebula from the side, it would look like the Dumbbell Nebula (M27). With this object, we're looking directly at the pole of the nebula.

### Dumbbell Nebula in the Vulpecula (Fox) constellation (M 27)

M 27 in the Fox constellation  
Right ascension: 19:59.6 (Hours: Minutes)  
Declination: +22:43 (Angle: Minutes)  
Distance: 1,250 light years

The Dumbbell Nebula (M 27) in Fox was the first planetary nebula ever discovered. On July 12, 1764, Charles Messier discovered this new and fascinating class of objects. We see this object almost directly from its equatorial plane. If you could see the Dumbbell Nebula from one of the poles, it would probably reveal the shape of a ring, and we would see something very similar to what we know from the Ring Nebula (M 57). In reasonably good weather, we can see this object well even with small magnifications.



## Telescope ABC's

### What do the following terms mean?

#### Diagonal:

A mirror that deflects the ray of light 90 degrees. With a horizontal telescope tube, this device deflects the light upwards so that you can comfortably observe by looking downwards into the eyepiece. The image in a diagonal mirror appears upright, but rotated around its vertical axis (mirror image.)

#### Focal Length:

Everything that magnifies an object via an optic (lens) has a certain focal length (FL). The FL is the length of the path the light travels from the surface of the lens to its focal point. The focal point is also referred to as the focus. In focus, the image is clear. In the case of a telescope, the FL of the telescope tube and the eyepieces are combined.

#### Lens:

The lens turns the light which falls on it around in such a way so that the light gives a clear image in the focal point after it has traveled a certain distance (focal length).

#### Eyepiece:

An eyepiece is a system made for your eye and comprised of one or more lenses. In an eyepiece, the clear image that is generated in the focal point of a lens is captured and magnified still more.

There is a simple formula for calculating the magnifications:

Focal length of the telescope tube / Focal length of the eyepiece = Magnification.

You see: In a telescope, the magnification depends on both the focal length of the telescope tube and the focal length of the eyepiece.

#### Magnification:

The magnification corresponds to the difference between observation with the naked eye and observation through a magnification apparatus (e.g. a telescope). In this scheme, observation with the eye is considered "single", or 1x magnification. Accordingly, if a telescope has a magnification of 30x, then a object viewed through the telescope will appear 30 times larger than it would with the naked eye. See also, "Eyepiece"

### Troubleshooting:

#### Mistakes:

#### Help:

#### No picture

Remove dust protection cap and sun-shield from the objective opening.

#### Blurred picture

Adjust focus using focus ring

#### No focus possible

Wait for temperature to balance out

#### Bad picture

Never observe through a glass surface

#### Viewing object visible in the finder, but not through the telescope

Adjust finder

#### Despite using star diagonal prism the picture is "crooked"

The star diagonal prism should be vertical in the eyepiece connection



#### DISPOSAL

Dispose of the packaging materials properly, according to their type (paper, cardboard, etc). Contact your local waste disposal service or environmental authority for information on the proper disposal.

Please take the current legal regulations into account when disposing of your device. You can get more information on the proper disposal from your local waste disposal service or environmental authority.

**Customer Service Questions:  
1.866.252.3811**

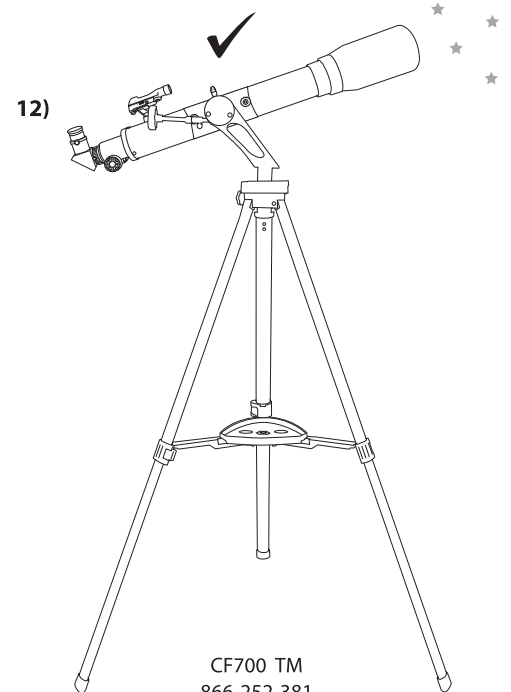
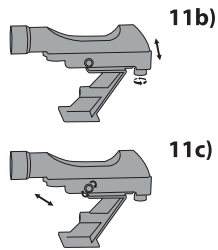
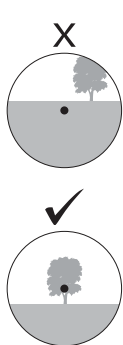
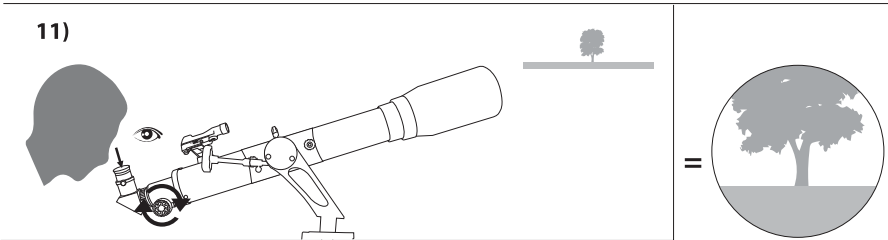
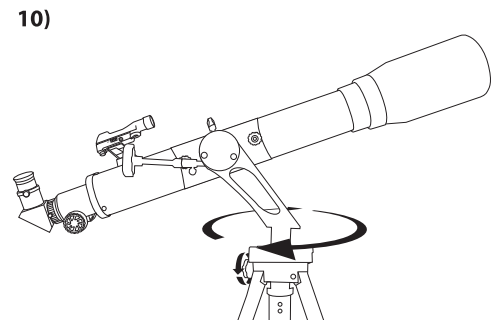
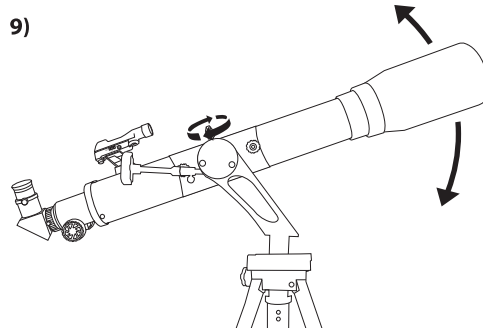
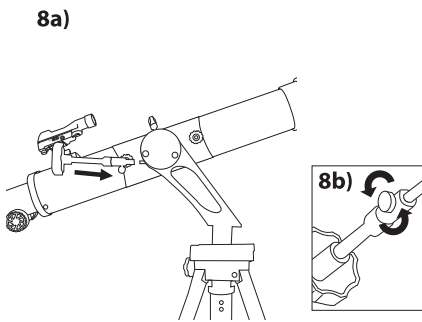
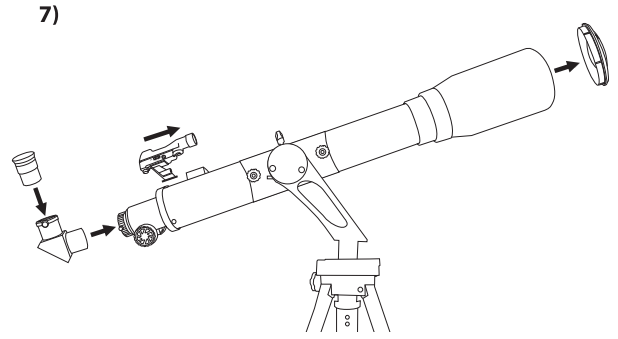
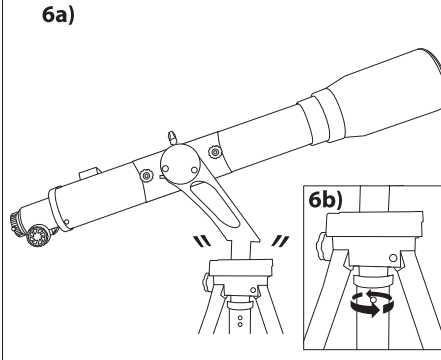
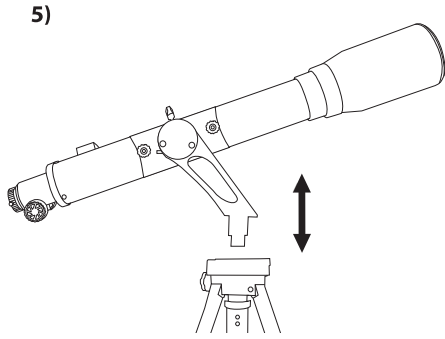
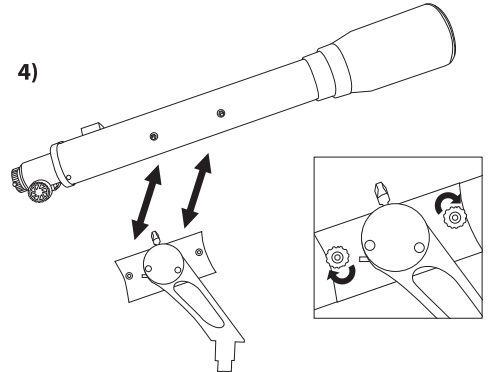
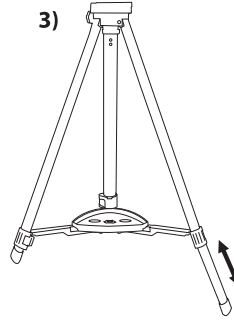
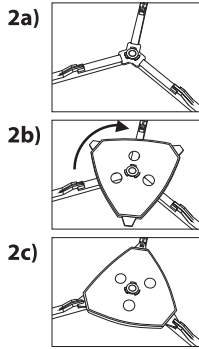
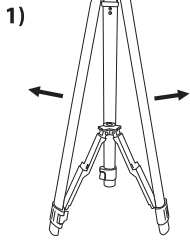





© 2016 National Geographic Partners, LLC. All rights reserved.  
NATIONAL GEOGRAPHIC and Yellow Border Design are trademarks  
of the National Geographic Society, used under license.

Visit our website: [www.nationalgeographic.com](http://www.nationalgeographic.com)

©2016 Explore Scientific®, LLC. All rights reserved.  
[explorescientific.com](http://explorescientific.com) | [exploreone.com](http://exploreone.com) | 866.252.3811  
Made in China.

CONFORMS TO THE SAFETY REQUIREMENTS OF ASTM F963