



DELUXE ADVENTURE SET

50 MM TELESCOPE W/ AZ PAN TILT MOUNT, 900X MICROSCOPE SET, COMPACT BINOCULARS INSTRUCTION MANUAL

Telescope Specifications

Optical design	Achromatic refractor
Magnification (with 2x Barlow lens)	30 - 48x (60 - 96x)
Front lens (clear aperture)	50 mm
Focal length	600 mm/f12
Standard eyepieces	0.965" (12.5 mm and 20 mm)
Finish	Carbon fiber
Accepts eyepiece barrel	24.5 mm (0.965")
Mounting	AZ Pan Handle Mount

Microscope Specifications

Eyepiece	20x
Lenses	5x, 20x, 45x
Magnification	100x, 400x, 900x
Accessories	Empty Vials, Spatula, Scalpel, Prepared Slides, Blank Slides, Tweezers, Needle, Stirring Rod, Pipette

Binocular Specifications

Lenses	30 mm
Magnification	4x

AA
1.5V
x2
NOT INCLUDED

Do not mix old and new batteries. Do not mix alkaline, standard (carbon-zinc), or rechargeable (ni-cad, ni-mh, etc.) batteries.

+
CR2032
3
x1
INCLUDED

WARNING:
SUN HAZARD – Never look directly at the sun with this device.

WARNING:
CHOKING HAZARD – Small parts. Not for children under 3 years.

WARNING:
FUNCTIONAL SHARP POINT – Not for children under 3 years.

WARNING:
Contains button or coin cell battery. Hazardous if swallowed – see instructions.



SUN WARNING

WARNING: NEVER ATTEMPT TO OBSERVE THE SUN WITH THIS DEVICE! OBSERVING THE SUN – EVEN FOR A MOMENT – WILL CAUSE INSTANT AND IRREVERSIBLE DAMAGE TO YOUR EYE OR EVEN BLINDNESS. EYE DAMAGE IS OFTEN PAINLESS, SO THERE IS NO WARNING TO THE OBSERVER THAT THE DAMAGE HAS OCCURRED UNTIL IT IS TOO LATE. DO NOT POINT THE DEVICE AT OR NEAR THE SUN. DO NOT LOOK THROUGH THE DEVICE AS IT IS MOVING. CHILDREN SHOULD ALWAYS HAVE ADULT SUPERVISION WHILE OBSERVING.

SAFETY WARNINGS

READ AND FOLLOW THE INSTRUCTIONS, SAFETY RULES, AND FIRST AID INFORMATION.

- RESPECT PRIVACY: WHEN USING THIS DEVICE, RESPECT THE PRIVACY OF OTHER PEOPLE. FOR EXAMPLE, DO NOT USE THEM TO LOOK INTO PEOPLE'S HOMES.
- CHOKING HAZARD: CHILDREN SHOULD ONLY USE DEVICE UNDER ADULT SUPERVISION. KEEP PACKAGING MATERIALS LIKE PLASTIC BAGS AND RUBBER BANDS OUT OF THE REACH OF CHILDREN AS THESE MATERIALS POSE A CHOKING HAZARD.
- RISK OF BLINDNESS: NEVER USE THIS DEVICE TO LOOK DIRECTLY AT THE SUN OR IN THE DIRECT PROXIMITY OF THE SUN. DOING SO MAY RESULT IN A PERMANENT LOSS OF VISION.
- RISK OF FIRE: DO NOT PLACE DEVICE, PARTICULARLY THE LENSES, IN DIRECT SUNLIGHT. THE CONCENTRATION OF LIGHT RAYS COULD CAUSE A FIRE.
- DO NOT DISASSEMBLE THIS DEVICE. IN THE EVENT OF A DEFECT, PLEASE CONTACT YOUR DEALER. THE DEALER WILL CONTACT THE CUSTOMER SERVICE DEPARTMENT AND CAN SEND THE DEVICE IN TO BE REPAIRED IF NECESSARY.
- DO NOT SUBJECT THE DEVICE TO TEMPERATURES EXCEEDING 60° C (140° F).



BUTTON/COIN BATTERY WARNING



WARNING:

This product contains a Button or Coin Cell Battery. A swallowed Button or Coin Cell Battery can cause internal chemical burns in as little as two hours and lead to death. Dispose of used batteries immediately. Keep new and used batteries away from children. If you think batteries might have been swallowed or placed inside any part of the body, seek immediate medical attention.

Instruction Manual, & Downloadable Planisphere Visit:

www.exploreone.com/pages/product-manuals



How To Set Up

Note: We recommend assembling your telescope for the first time in the daylight or in a lit room so that you can familiarize yourself with assembly steps and all components.

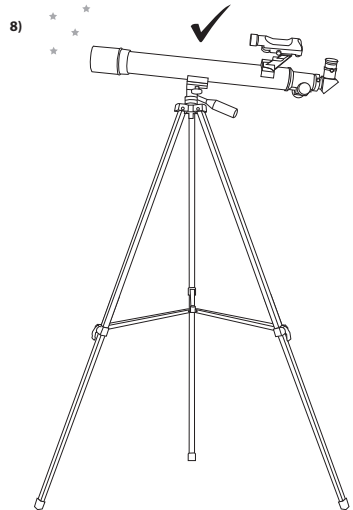
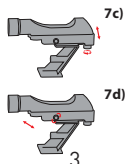
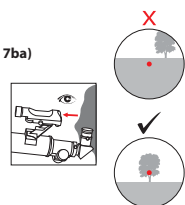
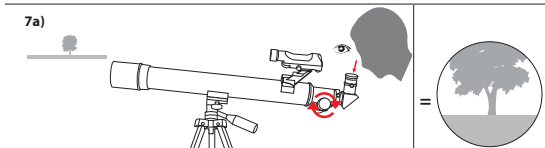
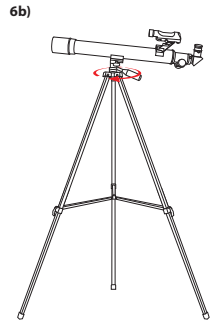
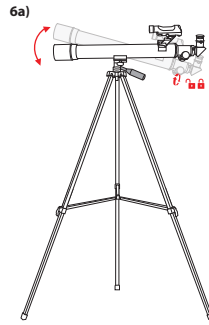
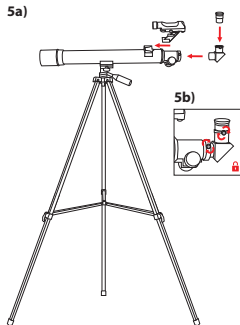
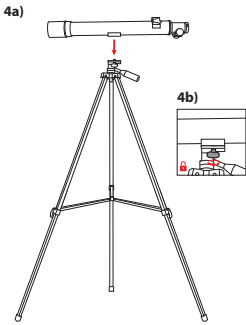
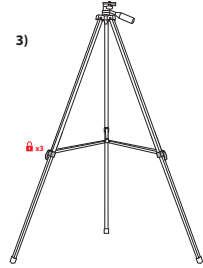
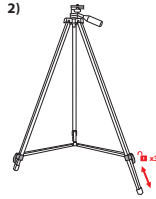
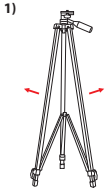



Parts Overview

1. 50mm Objective Lens
2. Pan-Tilt Alt-Azimuth Mount
3. Tripod
4. Optical Tube Assembly (OTA) with Dew Shield
5. Focus Wheel
6. Diagonal
7. 0.965" Eyepieces (12.5mm and 20mm)
8. Red Dot Viewfinder
9. Smartphone Adapter (phone not included)

Telescope Terms To Know:

Diagonal: A mirror that deflects the ray of light 90 degrees. With a horizontal telescope tube, this device deflects the light upwards so that you can comfortably observe by looking downwards into the eyepiece. The image in a diagonal mirror appears upright, but rotated around its vertical axis (mirror image).

Focal length: Everything that magnifies an object via an optic lens has a certain focal length. The focal length is the length of the path the light travels from the surface of the lens to its focal point. The focal point is also referred to as the focus. In focus, the image is clear. In the case of a telescope, the focal length of the telescope tube and the eyepieces are used to determine magnification.

Lens: The lens turns the light that falls on it around in such a way so that the light gives a clear image in the focal point after it has traveled a certain distance (focal length).

Eyepiece: An eyepiece is a system made for your eye and comprised of one or more lenses. In an eyepiece, the clear image that is generated in the focal point of a lens is captured and magnified still more.

Magnification: The magnification corresponds to the difference between observation with the naked eye and observation through a magnifying device like a telescope. If a telescope configuration has a magnification of 30x, then an object viewed through the telescope will appear 30 times larger than it would with the naked eye. To calculate the magnification of your telescope setup, divide the focal length of the telescope tube by the focal length of the eyepiece.

Using/Aligning the Red Dot Viewfinder:

The viewfinder is powered by a CR-2032 battery that is included. Before using the viewfinder for the first time, remember to remove the plastic insulator that is blocking the battery from connecting.

When it is time to replace the battery, remove the battery cap by loosening the set screw. Take out the old battery and slide a new battery in place with the positive side showing. Replace the cap, and tighten the set screw.

For The Viewfinder To Be Effective, It Must Be Aligned. To do this:

- Insert the 20mm eyepiece into the diagonal and power on the viewfinder by sliding the switch on its right side to an "On" position.
- Point the eyepiece at an easy to identify target like a telephone pole that is approximately 200 yards away. Center the object in the eyepiece. Lock the telescope into place by tightening the panhandle.
- Without moving the telescope, position the red dot using the two adjustment screws so that it shares the same view as the one in your eyepiece. The front screw will move the viewfinder up and down, and the other will move it side to side. Your viewfinder is now aligned.

Note: To preserve battery life, don't forget to turn off the viewfinder after use.

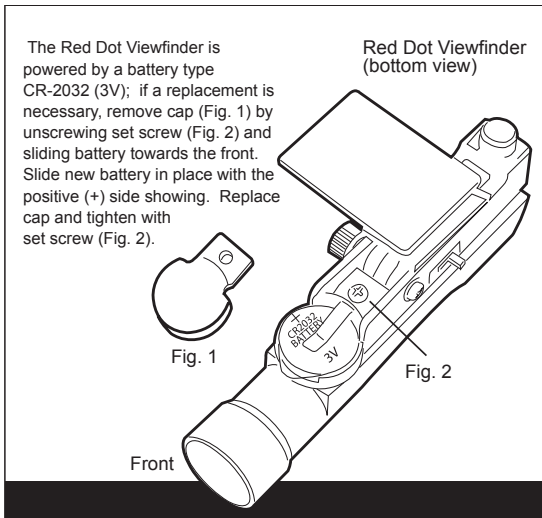

Using your telescope:

After you have aligned your viewfinder, you are ready to start observing!

Put the 20mm eyepiece into the diagonal to get the widest field of view. This wider field of view will make it easier to locate and track objects.

Use the panhandle to move the scope up, down and side to side until your target comes into view in the eyepiece. It is important to remember that the rotation of the Earth means objects will move out of your eyepiece fairly quickly. Once you have found and focused on your desired target, you can track it as it journeys across the night sky using the panhandle.

For a closer look at an object, you can insert the 12.5 mm eyepiece. The magnification will increase from 30x to 48x.

For a more closer look at an object, you can insert the 2x Barlow lens (if included). The magnification will increase to 60x for the 20 mm eyepiece and 96x for the 12.5 mm eyepiece.

Cleaning:

Your telescope is a precision optical device and keeping the optics free of dust and dirt is crucial for optimal performance. To clean the lenses (objective and eyepiece) use only a photo-grade soft brush or a lint-free cloth, like a microfiber cloth. Do not press down too hard while cleaning, as this might scratch the lens. Ask your parents to help if your telescope is really dirty. If necessary, the cleaning cloth can be moistened with an optical glass cleaning fluid and the lens wiped clean using very little pressure. Do not use harsh detergents!

Make sure your telescope is always protected against dust and dirt.

After use, leave it in a warm room to dry off before storing.

Possible Objects for Observation:

Terrestrial objects

Take note of the examples below, including Mount Rushmore and the golf course. Start with the 20 mm eyepiece and focus until the image is clear. After mastering the 20 mm eyepiece, switch to the 12.5 mm eyepiece and practice scanning and focusing until the image is clear. Choose several terrestrial objects to practice focusing on, but never point your telescope at or near the sun, or you risk blindness.

The Moon

Diameter: 3,476 km

Distance: Approximately 384,401 km

The Moon is the Earth's only natural satellite, and it is the second brightest object in the sky (after the Sun). Although it is our closest neighbor, a lot of people have never really taken a good long look at the Moon. With your telescope, you should be able to see several interesting lunar features. These include lunar maria, which appear as vast plains, and some of the larger craters. The best views will be found along the terminator, which is the edge where the visible and cloaked portions of the Moon meet.

Terrestrial Images

f=20 mm

f=12.5 mm



The Moon

f=20 mm

f=12.5 mm



Troubleshooting Guide:

Problem	Solution
No picture	Remove dust protection cap and sun-shield from the objective opening.
Blurred picture	Adjust focus using focus ring.
No focus possible	Wait for temperature to balance out.
Bad quality	Never observe through a glass surface such as a window.
Viewing object visible in the finder, but not through the telescope	Align finder to telescope (see instructions)
Despite using star diagonal prism the picture is "crooked"	The star diagonal prism should be vertical in the eyepiece connection.

SAFETY WARNINGS
READ AND FOLLOW THE INSTRUCTIONS, SAFETY RULES, AND FIRST AID INFORMATION.

- THIS MICROSCOPE SET IS INTENDED FOR CHILDREN OLDER THAN AGE 10. CHILDREN SHOULD ONLY USE THIS DEVICE UNDER ADULT SUPERVISION. NEVER LEAVE A CHILD UNSUPERVISED WITH THIS DEVICE. ACCESSORIES IN THE EXPERIMENT KIT MAY HAVE SHARP EDGES AND TIPS. PLEASE STORE THE DEVICE AND ALL OF ITS ACCESSORIES AND AIDS OUT OF THE REACH OF YOUNG CHILDREN WHEN NOT BEING USED DUE TO A RISK OF INJURY.
- CHEMICALS: ANY CHEMICALS AND LIQUIDS USED IN CONJUNCTION WITH THE DEVICE SHOULD BE KEPT OUT OF REACH OF CHILDREN. DO NOT DRINK ANY OF THE CHEMICALS CONTAINED IN THIS SET. HANDS SHOULD BE WASHED THOROUGHLY UNDER RUNNING WATER AFTER WORKING WITH THESE CHEMICALS. IN CASE OF ACCIDENTAL CONTACT WITH EYES OR MOUTH, RINSE THE AFFECTED AREA WITH WATER. SEEK MEDICAL TREATMENT FOR AILMENTS ARISING FROM CONTACT WITH THE CHEMICAL SUBSTANCE, AND TAKE THE CHEMICALS WITH YOU TO THE DOCTOR.
- CHOKING HAZARD: CHILDREN SHOULD ONLY USE DEVICE UNDER ADULT SUPERVISION. KEEP PACKAGING MATERIALS LIKE PLASTIC BAGS AND RUBBER BANDS OUT OF THE REACH OF CHILDREN AS THESE MATERIALS POSE A CHOKING HAZARD.
- BATTERY GUIDELINES: THIS DEVICE CONTAINS ELECTRONIC COMPONENTS THAT ARE POWERED BY BATTERIES. BATTERIES SHOULD BE KEPT OUT OF CHILDREN'S REACH. WHEN INSERTING BATTERIES, PLEASE ENSURE THE POLARITY IS CORRECT. INSERT THE BATTERIES ACCORDING TO THE DISPLAYED +/- INFORMATION. NEVER MIX OLD AND NEW BATTERIES. REPLACE ALL BATTERIES AT THE SAME TIME. NEVER MIX ALKALINE, STANDARD CARBON-ZINC AND RECHARGEABLE NICKEL-CADMIUM BATTERIES. NEVER SHORT CIRCUIT THE DEVICE OR BATTERIES OR THROW EITHER INTO A FIRE. LEAKING OR DAMAGED BATTERIES CAN CAUSE INJURY IF THEY COME INTO CONTACT WITH THE SKIN. IF YOU NEED TO HANDLE SUCH BATTERIES, PLEASE WEAR SUITABLE SAFETY GLOVES. REMOVE BATTERIES FROM THE PRODUCT BEFORE EXTENDED STORAGE TO PREVENT LEAKING. DO NOT IMMERSE THE BATTERY COMPARTMENT IN WATER.
- RISK OF FIRE: DO NOT PLACE DEVICE, PARTICULARLY THE LENSES, IN DIRECT SUNLIGHT. THE CONCENTRATION OF LIGHT RAYS COULD CAUSE A FIRE.
- DO NOT DISASSEMBLE THIS DEVICE. IN THE EVENT OF A DEFECT, PLEASE CONTACT YOUR DEALER. THE DEALER WILL CONTACT THE CUSTOMER SERVICE DEPARTMENT AND CAN SEND THE DEVICE IN TO BE REPAIRED IF NECESSARY.
- DO NOT SUBJECT THE DEVICE TO TEMPERATURES EXCEEDING 60° C (140° F).



- DISPOSAL: KEEP PACKAGING MATERIALS, LIKE PLASTIC BAGS AND RUBBER BANDS, AWAY FROM CHILDREN AS THEY A POSE A RISK OF SUFFOCATION. DISPOSE OF PACKAGING MATERIALS AS LEGALLY REQUIRED. CONSULT THE LOCAL AUTHORITY ON THE MATTER IF NECESSARY AND RECYCLE MATERIALS WHEN POSSIBLE.

**Instruction Manual, &
Downloadable Planisphere Visit:**

www.exploreone.com/pages/product-manuals



Using the Smartphone Adapter:

SUPERVISION BY ADULTS

Read and follow the instructions, safety rules and first aid information

CHEMICALS

Any chemicals and liquids used in preparing, using, or cleaning should be kept out of reach of children. Do not drink any chemicals. Hands should be washed thoroughly under running water after use. In case of accidental contact with the eyes or mouth rinse with water. Seek medical treatment for ailments arising from contact with the chemical substances and take the chemicals with you to the doctor.

Keep packaging materials (plastic bags, rubber bands, etc.) away from children. There is a risk of **SUFFOCATION**. Dispose of packaging materials as legally required. Consult the local authority on the matter if necessary.

DISPOSAL

Dispose of the packaging materials properly, according to their type, such as paper or cardboard. Contact your local waste-disposal service or environmental authority for information on the proper disposal. Please take the current legal regulations into account when disposing of your device. You can get more information on the proper disposal from your local waste-disposal service or environmental authority.

The Photo Imaging Adapter Set allows you to connect almost any "smart" device to a 1.25" Telescope. Allow the opening of a new world of fun and exploration. The Smart Adapter Pad is designed to support a variety of Smart Devices such as Phones, PDA's and Tablets and allows you to turn your Telescope into an Astro Photography System.

By incorporating the software provided in the link: <http://www.dotpdn.com/downloads/pdn.html>

You can enhance your images and create amazing technical displays or works of art creating a whole new direction for science and exploration.

The imaging software above is just an example of programs available for no cost or a small charge. Any of these types of software programs can be used to edit the amazing picture you have captured with your device.

The Smart Adapter Pad itself directly onto the telescope's eyepiece. Smart Adapter Pad is secured with the set screw. The set screw should be snug but not over tighten, as the set screw as this may damage the Smart Adapter Pad or Eyepiece. Then simply place the Smart Adapter Pad with the eyepiece install onto the instrument.

Taking your (Smart Device) Phone, PDA or Tablet: Simply align the camera lens over the eyepiece and center it. This is best done by opening the camera function and viewing the image on the device, to best center the device over the eyepiece. Depending on the size of the device and the instrument you are using: You may find it easier to install your Smart Device to the adapter and center the image, then install the entire unit onto the instrument. Example: If you are using a phone; you may find it easier to center the image with the eyepiece off the instrument and then press the phone, securing it onto the suction cup/non skid surface of the Smart Adapter Pad. For larger devices such as a tablet: You may find it easier to install the adapter and eyepiece on the instrument and then center the camera on the eyepiece while the adapter is attached to the instrument.

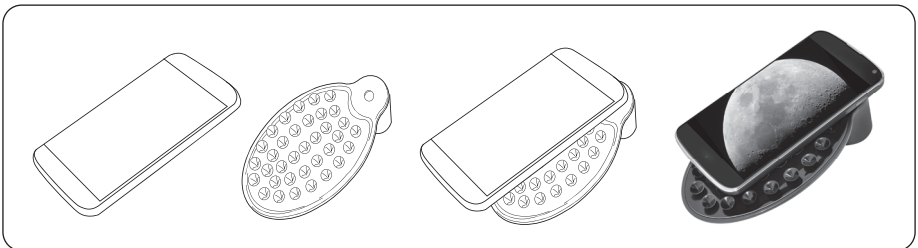

WARNING: The Weight of a device mounted on the Smart Adapter Pad Do not leave your device unsupported or unattended on the Smart Adapter Pad. The pad is not intended to secure, balance or support the device on its own and the operator should not let the device rest solely on the Smart Adapter Pad. Leaving the device unattended or allowing it to balance on its own without operator support, may result in the device falling, unbalancing the entire instrument and possibly damaging the instrument or your device.

Though the surface of the Adapter Pad is designed with suction cups and to be non skid: The manufacturer cannot assure that this will support the various devices weight or guarantee it will adhere to all surfaces on various smart devices. Never allow the Smart Adapter Pad to support your Smart Device without you supporting the item.

Once you have the Smart Adapter Pad installed and the device centered and supported: Simply focus the instrument as directed in the devices instructions to achieve the clearest image and then use the camera or video system function in your device to capture or record the image.

Customer Service: Call 1-866-252-3811



Parts Overview

1. Eyepiece
2. Focus Knob
3. Stage
4. Metal Stage Clips
5. Objective
6. Objective Turret
(5x, 20x, 45x)
7. Illumination On/Off Switch and Mirror
8. Battery Case Cover
9. Microscope Arm

10. (3) Prepared Slides and (3) Blank Slides
11. (3) Slide Covers & Labels
12. (3) Collection Vials
13. Spatula
14. Scalpel*
15. Tweezers/Stirring Rod/Pipette

*Not suitable for children under 3 years of age.
Contains functional sharp points.

Observe, Investigate, Discover!

When you want to take your investigations to the cellular level, the 900x Microscope is ready to reveal the hidden details of the world around you. Everyday things like sand, onion skin, hair and pollen will show their extraordinary sides when viewed at magnifications ranging from 100x to 900x. To jumpstart your observations, the set comes with prepared specimens, collection tools and an experiment guide.

How Do I Use My Microscope

Before you use your microscope, make sure that the table, desk or surface that you place it on is stable and is not subject to vibration. If the microscope needs to be moved, hold it by the arm and base while carefully transferring it. Once the microscope is in a suitable location and the batteries are installed, check the light source to make sure that it illuminates. Use a microfibre cleaning cloth to gently wipe the lenses off. If the stage is dirty with dust or oil, carefully clean it off. Make sure that you only raise and lower the stage using the focus adjustment knob.

How Do I Operate The Illumination?

Locate the mirror/light on the base of the microscope. Flip the mirror/light to the “on” position (with the light facing up) and the light will illuminate. This microscope is equipped with an incandescent light that illuminates the specimen from below.

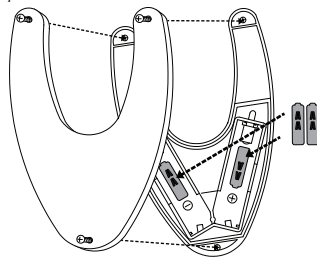

How Do I Adjust My Microscope Correctly?

Place the microscope in a suitable location as described above, and sit in a comfortable viewing position. Always start each observation with the lowest magnification. Adjust the distance of the microscope stage so that the stage is in the lowest position — farthest away from the turret head. Turn the objective turret until it clicks into place at the lowest magnification (Objective: 5x/Magnification: 100x). Note: Before you change the objective setting, always make sure the microscope stage is farthest away from the turret by rotating the focus knob. Separating the stage and turret by rotating the focus knob will avoid causing damage to the specimen slide or microscope. When starting an observation, always start with the 5x objective in the rotating head.

Troubleshooting Guide:

Problem	Solution
No recognizable image	Turn on light, Readjust focus, Start with the lowest power objective (5x)
No image	Centre object on slide under lowest power objective
No light	Replace batteries, Check on/off position

How Do I Observe The Specimen?

Sitting in your location with adequate illumination chosen from the colour filter wheel, the following basic rules should be observed. Start with a simple observation at the lowest magnification. Position the object or specimen in the middle of the stage under the stage clips, centred over the lower light. Focus the image by rotating the focus knob until a clear image appears in the eyepiece.

Place the prepared slide directly under the objective on the microscope stage and secure it with the stage clips. The prepared slide should be located directly over the lower illumination. Look through the eyepiece and carefully turn the focus knob until the image appears clear and sharp. Now you can select a higher magnification by rotating to the 15x/300x objective turret. Higher levels of magnification can be achieved by turning the objective turret to a higher setting (300x or 900x). Following this procedure creates a steady increase of magnification without overpowering the view of the object. The following magnification order should be used: 100x, 300x then 900x. Each time the magnification changes (due to the objective change), the image sharpness must be readjusted with the focus knob. When doing this, be careful because if you move the microscope stage too quickly, the objective and the slide could come into contact and cause damage to the slide or microscope.

Magnification Guide:

Eyeiece	Objective	Power
20x	5x	100x
20x	20x	400x
20x	45x	900x

For transparent objects (e.g. sea salt), light is projected by the lower light traveling from below the stage, through the objective and eyepiece, and finally into your eye. This process of light transmission is known as microscopy. Many micro-organisms found in water, plant components and the smallest animal parts are transparent in nature. Opaque specimens, on the other hand, will need to be prepared for viewing. Opaque specimens can be made transparent by a process of treatment and penetration with the correct materials (media), or by slicing. You can read more about creating specimens in the enclosed microscope experiments booklet.



SUN WARNING

WARNING: NEVER ATTEMPT TO OBSERVE THE SUN WITH THIS DEVICE! OBSERVING THE SUN – EVEN FOR A MOMENT – WILL CAUSE INSTANT AND IRREVERSIBLE DAMAGE TO YOUR EYE OR EVEN BLINDNESS. EYE DAMAGE IS OFTEN PAINLESS, SO THERE IS NO WARNING TO THE OBSERVER THAT THE DAMAGE HAS OCCURRED UNTIL IT IS TOO LATE. DO NOT POINT THE DEVICE AT OR NEAR THE SUN. DO NOT LOOK THROUGH THE DEVICE AS IT IS MOVING. CHILDREN SHOULD ALWAYS HAVE ADULT SUPERVISION WHILE OBSERVING.

SAFETY WARNINGS

READ AND FOLLOW THE INSTRUCTIONS, SAFETY RULES, AND FIRST AID INFORMATION.

- **RESPECT PRIVACY:** WHEN USING THIS DEVICE, RESPECT THE PRIVACY OF OTHER PEOPLE. FOR EXAMPLE, DO NOT USE THEM TO LOOK INTO PEOPLE'S HOMES.
- **CHOKING HAZARD:** CHILDREN SHOULD ONLY USE DEVICE UNDER ADULT SUPERVISION. KEEP PACKAGING MATERIALS LIKE PLASTIC BAGS AND RUBBER BANDS OUT OF THE REACH OF CHILDREN AS THESE MATERIALS POSE A CHOKING HAZARD.
- **RISK OF BLINDNESS:** NEVER USE THIS DEVICE TO LOOK DIRECTLY AT THE SUN OR IN THE DIRECT PROXIMITY OF THE SUN. DOING SO MAY RESULT IN A PERMANENT LOSS OF VISION.
- **RISK OF FIRE:** DO NOT PLACE DEVICE, PARTICULARLY THE LENSES, IN DIRECT SUNLIGHT. THE CONCENTRATION OF LIGHT RAYS COULD CAUSE A FIRE.
- **DO NOT DISASSEMBLE THIS DEVICE.** IN THE EVENT OF A DEFECT, PLEASE CONTACT YOUR DEALER. THE DEALER WILL CONTACT THE CUSTOMER SERVICE DEPARTMENT AND CAN SEND THE DEVICE IN TO BE REPAIRED IF NECESSARY.
- **DO NOT SUBJECT THE DEVICE TO TEMPERATURES EXCEEDING 60° C (140° F).**



- **DISPOSAL:** KEEP PACKAGING MATERIALS, LIKE PLASTIC BAGS AND RUBBER BANDS, AWAY FROM CHILDREN AS THEY A POSE A RISK OF SUFFOCATION. DISPOSE OF PACKAGING MATERIALS AS LEGALLY REQUIRED. CONSULT THE LOCAL AUTHORITY ON THE MATTER IF NECESSARY AND RECYCLE MATERIALS WHEN POSSIBLE.

Customer Service: Call 1-866-252-3811



Parts Overview

1. Compact Binocular
2. Central Focusing Wheel
3. Eyepiece Lens
4. Objective Lens
5. Optical Tube
6. Lanyard (behind binoculars not shown)
7. Carry Bag

Discover The World Around!

Your National Geographic compact binoculars are the perfect companion for countless outdoor adventures. With these sturdy binoculars, you can investigate amazing species and sights. Take them on a nature walk to get a detailed look at birds and other wildlife without disturbing them. Take them on a hike to navigate your path and view distant landmarks. Most of all, keep them close by for on-the-go exploration.

Determining Eye Distance

The distance between one's eyes varies from person to person, so it is essential that you adjust your binoculars before you use them. Take the binoculars in both hands (Fig. 1) and hold them to your eyes. Fold them so that you see a single circle when looking through them (Fig. 2).

Adjusting The Focus

To adjust the focus, simply turn the center focus wheel (Fig. 3).

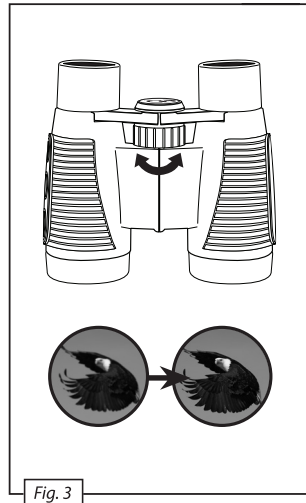
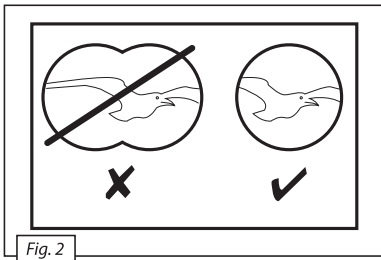
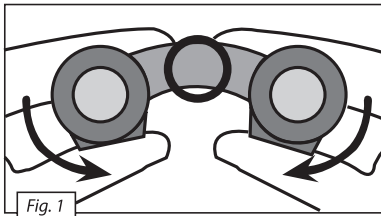

Cleaning Instructions

To clean the eyepieces and/or objective lenses, only use a soft, lint-free cloth like a microfiber cloth. Do not apply excess pressure to the cloth to avoid scratching the lenses. To remove more stubborn dirt, moisten the cleaning cloth with an eyeglass-cleaning solution and wipe the lenses gently being careful to avoid excess pressure. Protect this device from dust and moisture. When using in high humidity conditions, let the device acclimatize for a short period of time before storing so that residual moisture can dissipate.

Notes



Notes

Notes



Notes

Notes



**©2018 National Geographic Partners LLC. All rights reserved.
NATIONAL GEOGRAPHIC and Yellow Border Design are trademarks of the
National Geographic Society, used under license.**

**©2018 Explore Scientific, LLC.
1010 S. 48th Street, Springdale AR 72762
All rights reserved. explorescientificusa.com | exploreone.com | 866.252.3811
Made in China**

CONFORMS TO THE SAFETY REQUIREMENTS OF ASTM F963