

EXPLORE SCIENCE

12+



V8

OVER
270
PIECES

MODEL ENGINE

AA
1.5V

**x3
NOT INCLUDED**

Do not mix old and new batteries. Do not mix alkaline, standard (carbon-zinc), or rechargeable (ni-cad, ni-mh, etc.) batteries. Non-rechargeable batteries are not to be recharged. Please recycle batteries responsibly.



WARNING:
CHOKING HAZARD – Small parts.
Not for children under 3 years.

IMPORTANT SAFETY INSTRUCTIONS

READ AND FOLLOW THE INSTRUCTIONS BEFORE USE.
KEEP THESE INSTRUCTIONS FOR LATER USE.

• ADULT SUPERVISION AND ASSISTANCE IS REQUIRED. THIS UNIT IS ONLY FOR USE BY CHILDREN AGED 12 YEARS AND OLDER.

• READ AND FOLLOW ALL INSTRUCTIONS IN THE MANUAL BEFORE USE.

THIS TOY CONTAINS SMALL PARTS AND FUNCTIONAL SHARP POINTS ON COMPONENTS.

KEEP AWAY FROM CHILDREN UNDER AGE 3 YEARS.

PLEASE RETAIN THE INFORMATION AND THIS MANUAL FOR FUTURE REFERENCE.

FOLLOW THE INSTRUCTION MANUAL TO PERFORM THE CIRCUIT CONNECTION.

INSTRUCTIONS FOR PARENTS ARE INCLUDED AND HAVE TO BE OBSERVED.

DO NOT LOCK THE MOTOR OR OTHER MOVING PARTS. OTHERWISE IT MAY CAUSE OVERHEATING.

THE TOY IS NOT TO BE CONNECTED TO MORE THAN THE RECOMMENDED NUMBER OF POWER SUPPLIES.

WARNING. DO NOT USE CLOSE TO THE EAR! MISUSE MAY CAUSE DAMAGE TO HEARING.



• **CHOKING HAZARD:** CHILDREN SHOULD ONLY USE DEVICE UNDER ADULT SUPERVISION. KEEP PACKAGING MATERIALS LIKE PLASTIC BAGS AND RUBBER BANDS OUT OF THE REACH OF CHILDREN AS THESE MATERIALS POSE A CHOKING HAZARD.

• **DO NOT DISASSEMBLE THIS DEVICE:** IN THE EVENT OF A DEFECT, PLEASE CONTACT YOUR DEALER. THE DEALER WILL CONTACT THE CUSTOMER SERVICE DEPARTMENT AND CAN SEND THE DEVICE IN TO BE REPAIRED IF NECESSARY.

• **BATTERY INFORMATION:**

USE 3 X AA SIZE BATTERIES (NOT INCLUDED)

REMOVE BATTERIES WHEN NOT IN USE.

BATTERIES MUST BE INSERTED WITH THE CORRECT POLARITY.

NON-RECHARGEABLE BATTERIES ARE NOT TO BE RECHARGED.

RE-CHARGEABLE BATTERIES ARE ONLY TO BE CHARGED UNDER ADULT SUPERVISION.

RE-CHARGEABLE BATTERIES ARE TO BE REMOVED FROM THE TOY BEFORE BEING CHARGED.

DIFFERENT TYPES OF BATTERIES OR NEW AND USED BATTERIES ARE NOT TO BE MIXED.

ONLY BATTERIES OF THE SAME OR EQUIVALENT TYPES ARE TO BE USED.

EXHAUSTED BATTERIES ARE TO BE REMOVED FROM THE TOY.

THE SUPPLY TERMINALS ARE NOT TO BE SHORT-CIRCUITED.

DO NOT DISPOSE OF THE BATTERIES IN FIRE.

DO NOT MIX OLD AND NEW BATTERIES.

DO NOT MIX ALKALINE, CARBON ZINC AND RE-CHARGEABLE BATTERIES.



• **DISPOSAL:** KEEP PACKAGING MATERIALS, LIKE PLASTIC BAGS AND RUBBER BANDS, AWAY FROM CHILDREN AS THEY POSE A RISK OF SUFFOCATION. DISPOSE OF PACKAGING MATERIALS AS LEGALLY REQUIRED. CONSULT THE LOCAL AUTHORITY ON THE MATTER IF NECESSARY AND RECYCLE MATERIALS WHEN POSSIBLE.



• THE WEEE SYMBOL IF PRESENT INDICATES THAT THIS ITEM CONTAINS ELECTRICAL OR ELECTRONIC COMPONENTS WHICH MUST BE COLLECTED AND DISPOSED OF SEPARATELY.

• NEVER DISPOSE OF ELECTRICAL OR ELECTRONIC WASTE IN GENERAL MUNICIPAL WASTE. COLLECT AND DISPOSE OF SUCH WASTE SEPARATELY.

• MAKE USE OF THE RETURN AND COLLECTION SYSTEMS AVAILABLE TO YOU, OR YOUR LOCAL RECYCLING PROGRAM. CONTACT YOUR LOCAL AUTHORITY OR PLACE OF PURCHASE TO FIND OUT WHAT SCHEMES ARE AVAILABLE.

• ELECTRICAL AND ELECTRONIC EQUIPMENT CONTAINS HAZARDOUS SUBSTANCES WHICH, WHEN DISPOSED OF INCORRECTLY, MAY LEAK INTO THE GROUND. THIS CAN CONTRIBUTE TO SOIL AND WATER POLLUTION WHICH IS HAZARDOUS TO HUMAN HEALTH, AND ENDANGER WILDLIFE.

• IT IS ESSENTIAL THAT CONSUMERS LOOK TO RE-USE OR RECYCLE ELECTRICAL OR ELECTRONIC WASTE TO AVOID IT GOING TO LANDFILL SITES OR INCINERATION WITHOUT TREATMENT.

CUSTOMER SERVICE CALL: 866.252.3811

Introduction

Internal combustion engine is a machine that makes use of combustion of a fuel to provide mechanical power. It was not invented by a single person. Infact various scientists and engineers contributed to its development since the 19th century and nowadays it is a common mechanical unit in many different aspects. One of the most common places you will find them in is inside the car. Internal combustion engine is like the heart of a vehicle --- It provides the power for the car to run!

What is the difference between an electric motor and an internal combustion engine?

A electric motor makes use of electricity to create rotatory motion. Basically, it consists of magnets and coils. When electricity flows through the coils in the motor, the electro-magnetic force (attraction towards a magnet/repulsive force away from a magnet) drives the coils to move. Actually, the rotatory output of a motion originates from such electro-magnetic force.

An internal combustion engine makes use of the “combustion” of a fuel such as petrol. In simple, first a small amount of petrol is sprayed (in the form of a gas mixture) inside the combustion chamber. Then, a spark ignites the air-fuel mixture. The abrupt combustion of the air-fuel mixture is pretty much like a very small-scale explosion. This small-scale explosion provides the propellent force as the mechanical power output for the internal combustion engine.

Remark:

An important difference between the petrol engine and the diesel engine is, the diesel engine does not need a spark to ignite the diesel spray. The ignition of the diesel spray is triggered by the heat produced by air compression. Anyway, both types of engines make use of the same principle (combustion of fuels like a small-scale explosion) to provide power.

How to differentiate if a vehicle/vessel is using an electric motor or an internal combustion engine?

If the machine needs fill in liquid fuel for power, then it should be using an internal combustion engine. If the machine needs to charge up for electricity, then it should be using an electric motor.

How many types of internal combustion engine are there?

It depends on what criteria you use to differentiate them. For example, the internal combustion engine for the car is very different from that of the areophone. And then, among the car engines, there is spark ignition engine (using spark to ignite the petrol spray) and compression ignition engine (no spark, but by compressing the air to provide heat to ignite the diesel spray). And among them there are engines of 2-stroke cycle, 4-stroke cycle and 6-stroke cycle (6-stroke cycle is for spark ignition engine only).

This V8 Model Engine is a simulation of a 4-stroke-cycle V8 petrol engine. It is called V8 because there are a total of 8 cylinders(the combustion takes place in a cylinder) and they are arranged in “V” shape. Therefore in this manual, we will focus on this particular type of internal combustion engine.

What is a 4-stroke-cycle and how a 4-stroke engine works?

As said earlier, the working principle of an internal combustion engine is like this: First a small amount of petrol is sprayed (in the form of a gas mixture) inside the combustion chamber. And then, a spark ignites the air-fuel mixture. The abrupt combustion of the air-fuel mixture is pretty much like a very small-scale explosion. This small-scale explosion provides the propellent force as the mechanical power output of the internal combustion engine.

This combustion process, which is pretty much like a very small-scale explosion, takes place in the combustion chamber. The combustion chamber is also called a cylinder. These diagrams demonstrate the key process inside a cylinder during the operation of this type of internal combustion engine:

The 1st cycle - Intake

The shaft rotates and as a result the piston moves downwards, allowing the air-fuel mixture (air mix with volatilized petrol) to fill the cylinder.

* At the top left of the diagram, the inlet valve is opened to let the air-fuel mixture to flow into the cylinder

[If you wonder "where does the power come from?" that rotates the shaft in this cycle, read through all 4 cycles and you will find the answer in the end]

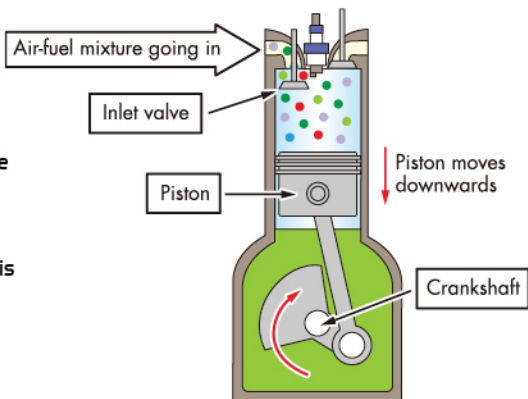

The 2nd cycle - Compression

The shaft continues to rotate and then the piston moves upwards, compressing the air-fuel mixture in the cylinder.

* Note that at the top left of the diagram, the valve is closed so that the air-fuel mixture is trapped inside the cylinder for the compression to take place.

[If you wonder "where does the power come from?" that rotates the shaft in this cycle, read through all 4 cycles and you will find the answer in the end.]

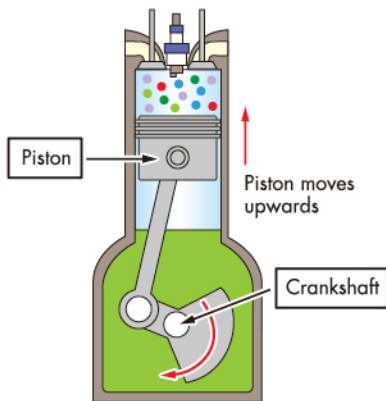

The 3rd cycle - Power

The spark plug is the igniter. It makes a spark, igniting the air-fuel mixture. The air-fuel mixture immediately combusts. This is pretty much like a very small-scale explosion that pushes the piston downwards. When the piston is pushed downwards, it cranks the shaft. This is called a power stroke, which is the source of power for the engine.

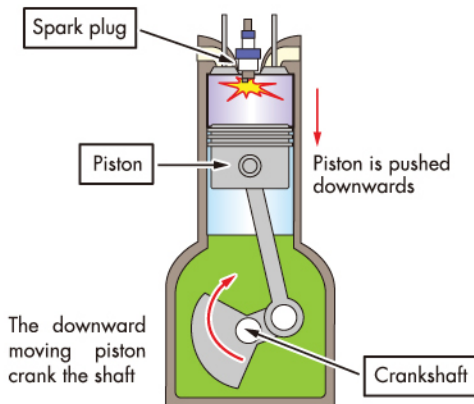

The 4th cycle - Exhaust

The shaft continues to rotate and the piston moves upwards, expelling the exhausted gas completely.

* Note that at the top right of the diagram, the exhaust valve is opened for the exhausted gas to leave.

And then the shaft keeps on rotating and back to the 1st cycle and continue the process.

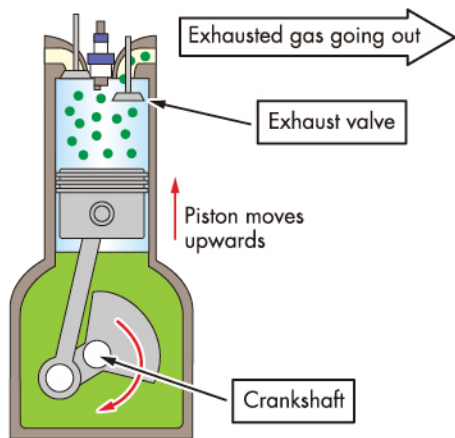

Where does the power come from that rotates the shaft to move the piston up and down in the 1st, 2nd and 4th cycle?

In an ordinary 4-stroke cycle engine, there will be 4 cylinders. They won't be at the same cycle at the same time. In fact, they all will be at a different cycle. To put it simple, let's call the 4 cylinders A, B, C, D.

First, when A is at the 1st cycle, B will be at the 2nd, C will be at the 3rd, D will be at the 4th. Then, when A is at the 2nd cycle, B will be at the 3rd, C will be at the 4th, D will be at the 1st. Then, when A is at the 3rd cycle, B will be at the 4th, C will be at the 1st, D will be at the 2nd. Then, when A is at the 4th cycle, B will be at the 1st, C will be at the 2nd, D will be at the 3rd. And the process keeps on.....

So that there will always be a cylinder that is at the 3rd cycle that provides the power!

In a V8 engine, there are 8 cylinders. This is basically the same as 4 cylinders ones, except the fact that the crankshaft is now cranked by 8 pistons, instead of 4. Therefore it has more power and smoother power output.

How to start the engine from stationary?

When you understand the working principle of 4-stroke-cycle, naturally a question would come up in the mind: what about at the beginning, when the engine is off, the shaft is not moving, no power is there at the moment, and then how to turn it on? How to make it start the process?

The answer is, for modern car engine it will come up with a "starter", which is an electric motor unit to crank the crankshaft at the beginning. Once the crankshaft is rotating, the 4-stroke-cycle can start.

What controls the opening and the closing of the valves?

The opening and the closing of the valves is controlled by the system of "timing belt + camshaft + rocker shaft". In simple, when the crankshaft rotates, it also drives the timing belt to move. The timing belt then drives the camshaft and rocker shaft to rotate accordingly. The details are difficult to express in words. When you build the V8 engine kit, the part of "timing belt + camshaft + rocker shaft", trying turning them a few times to see. You will see how the smart design of such system makes the valves open or close at the proper time automatically.

COMPONENT LIST

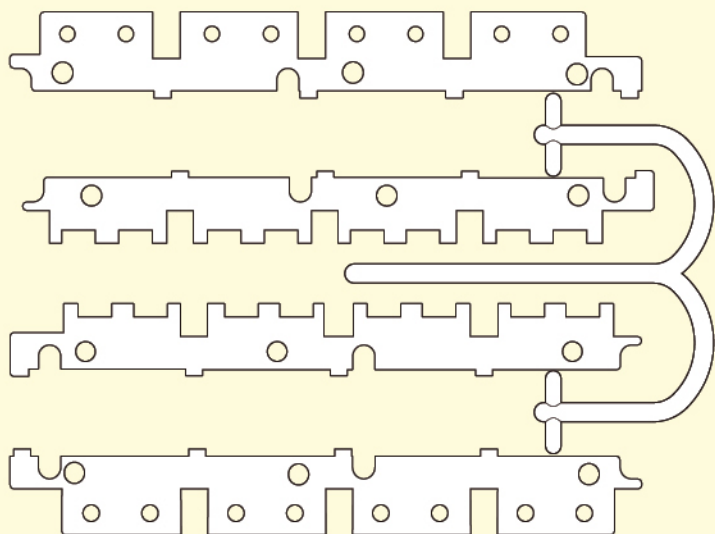
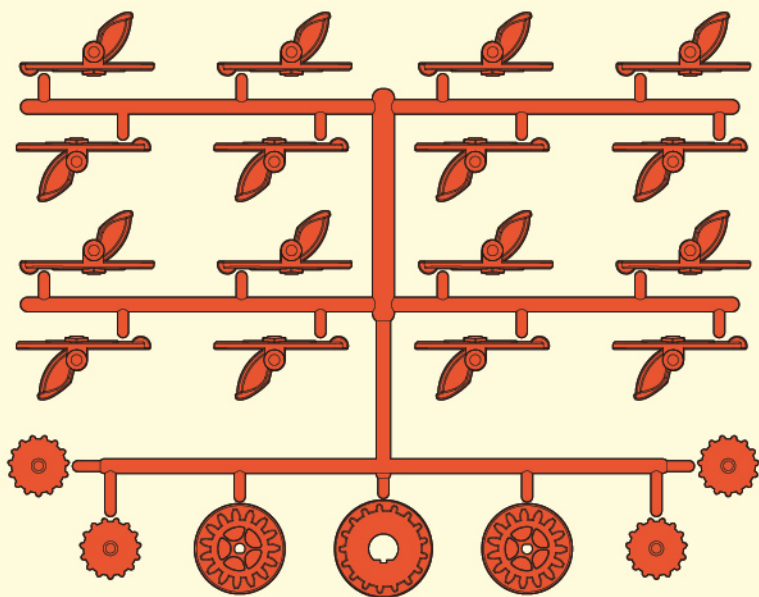

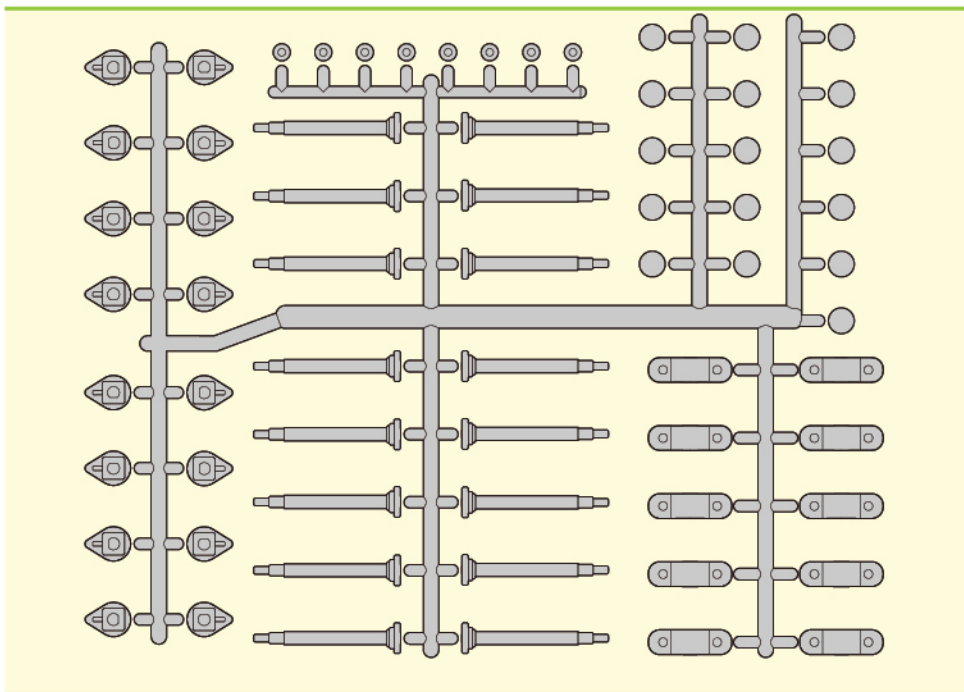
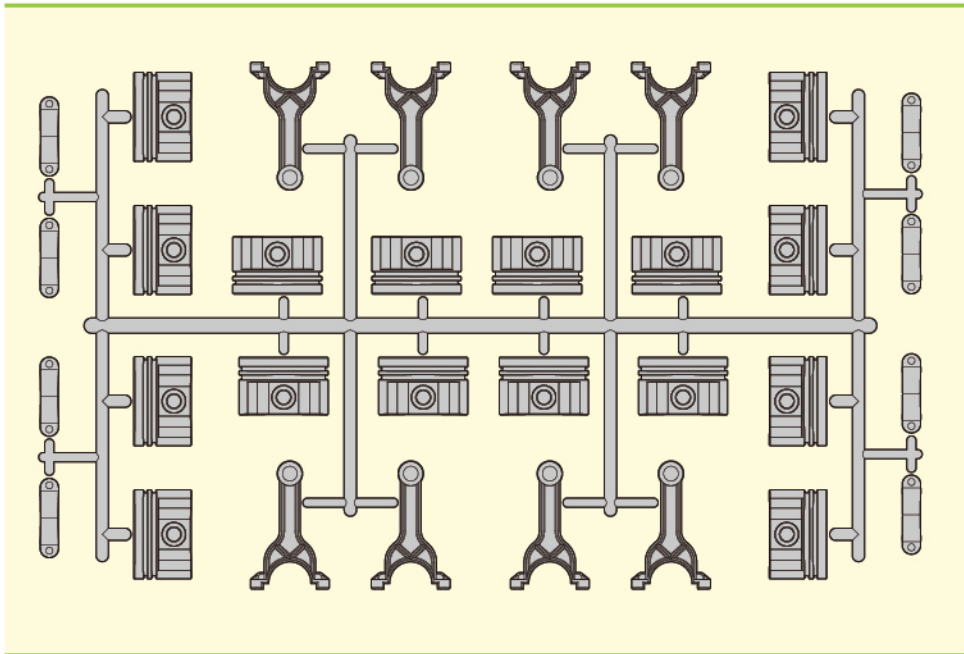

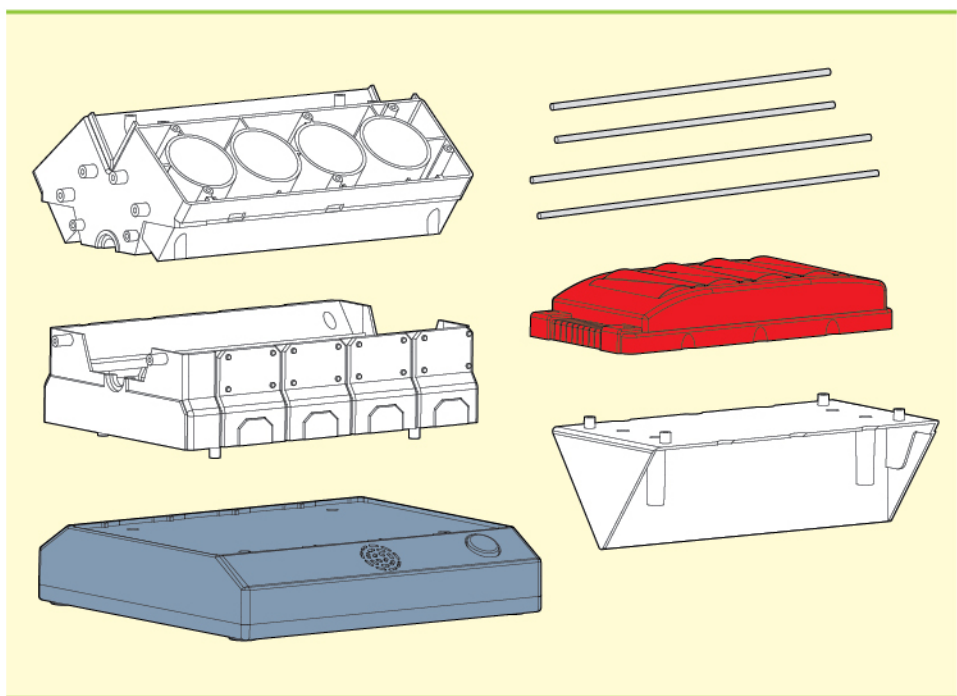
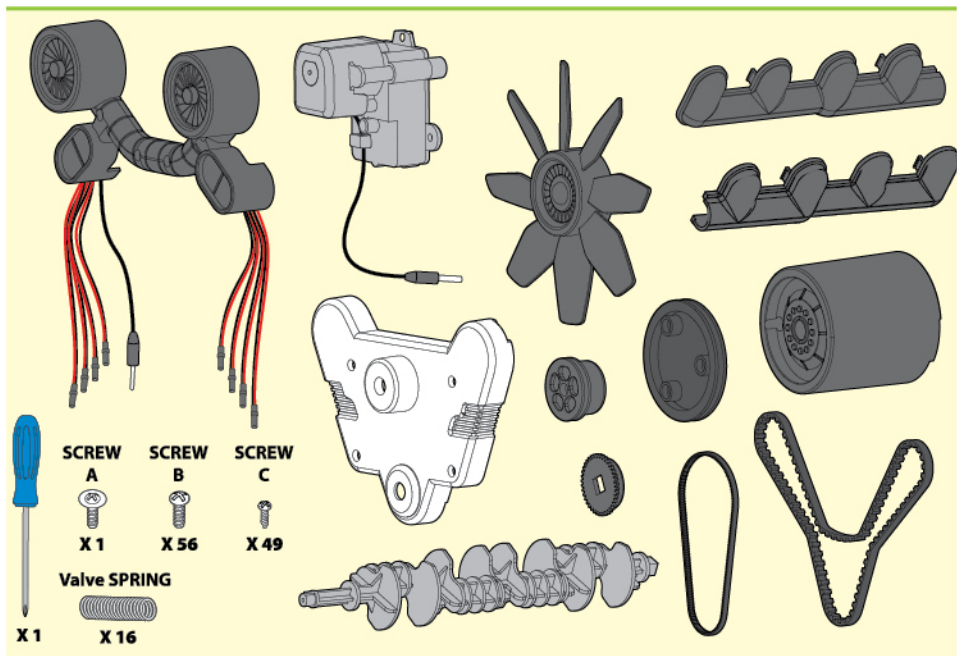

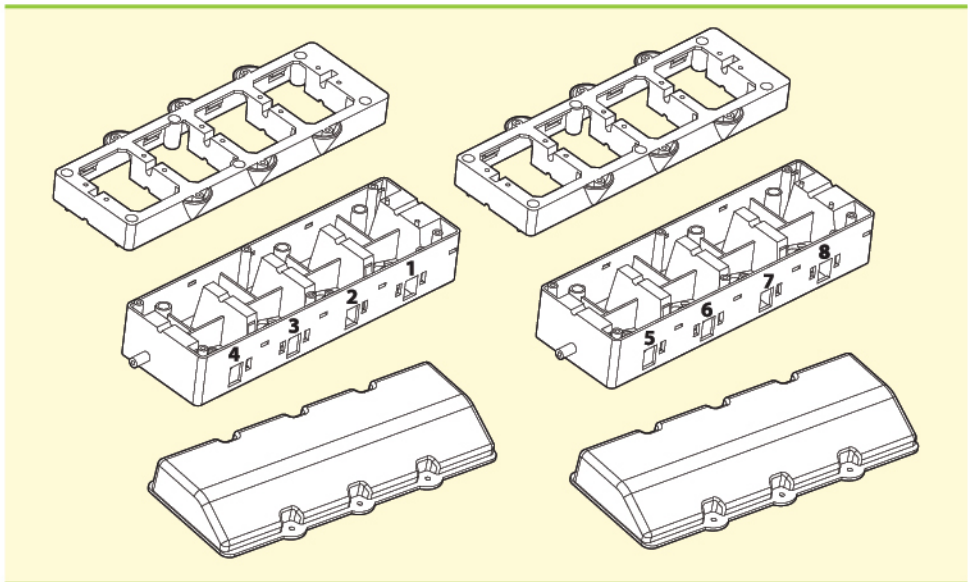

ASSEMBLY

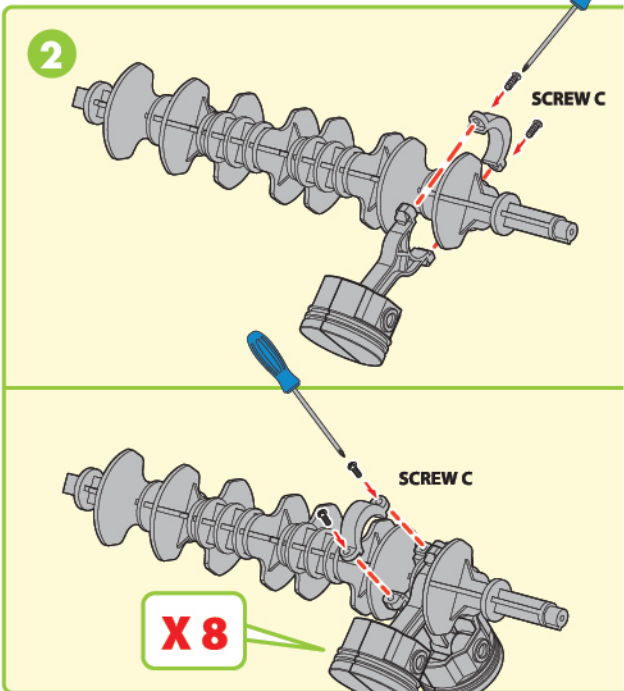
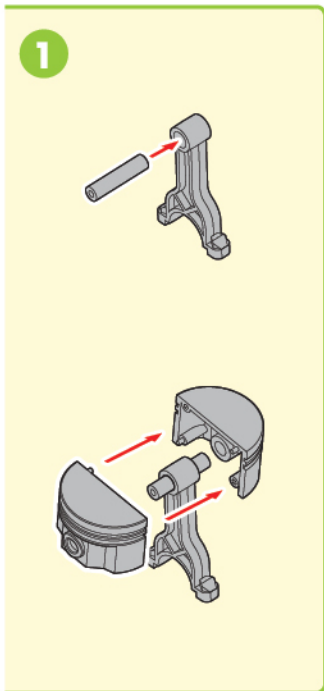



3

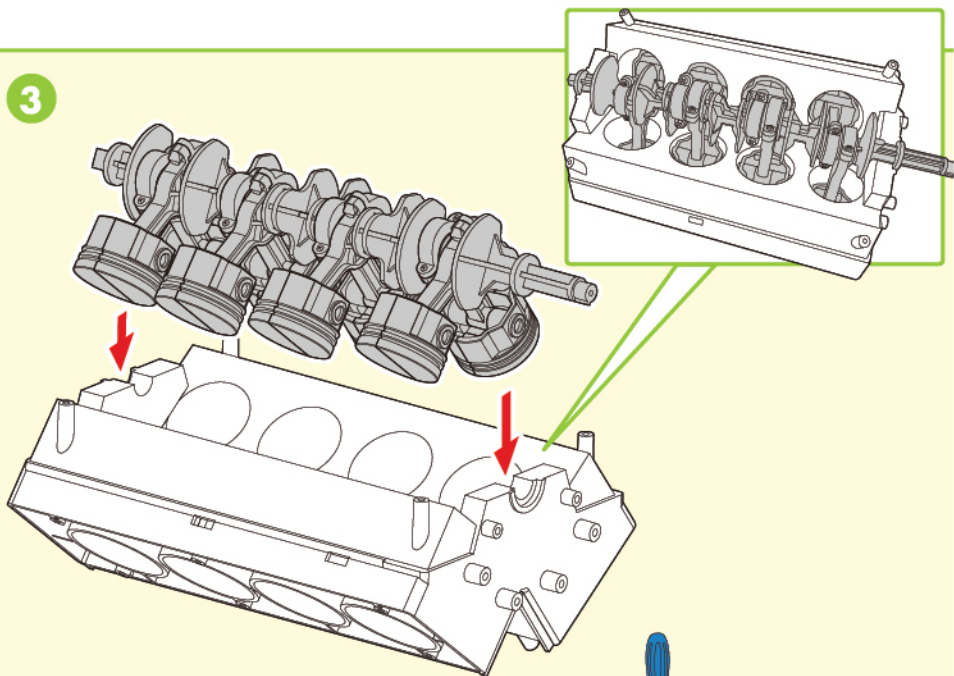

4

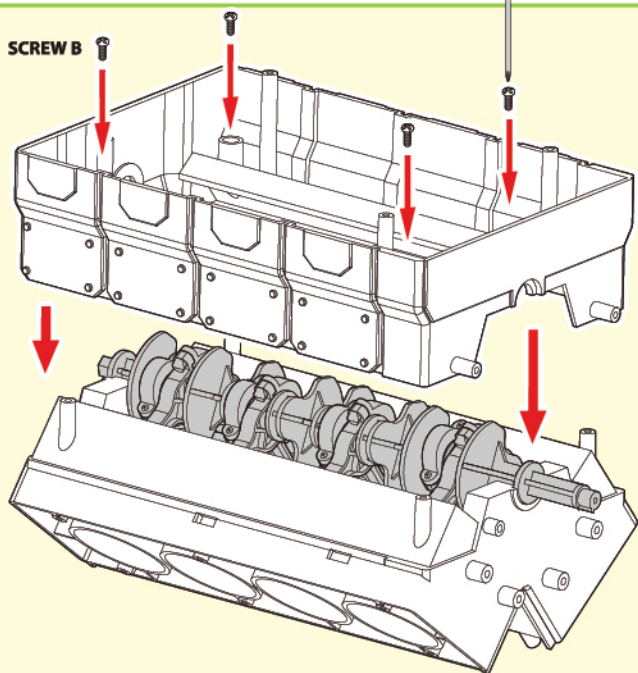

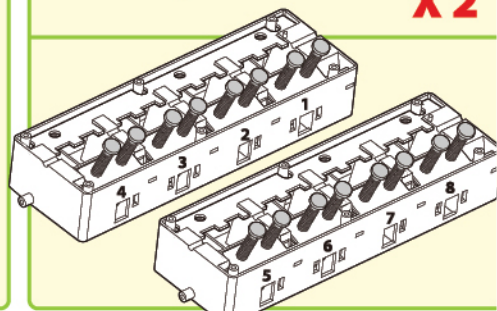
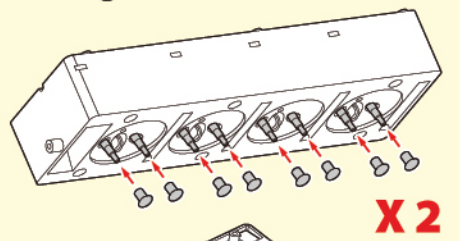
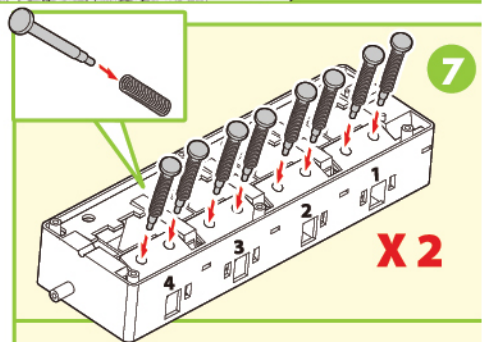
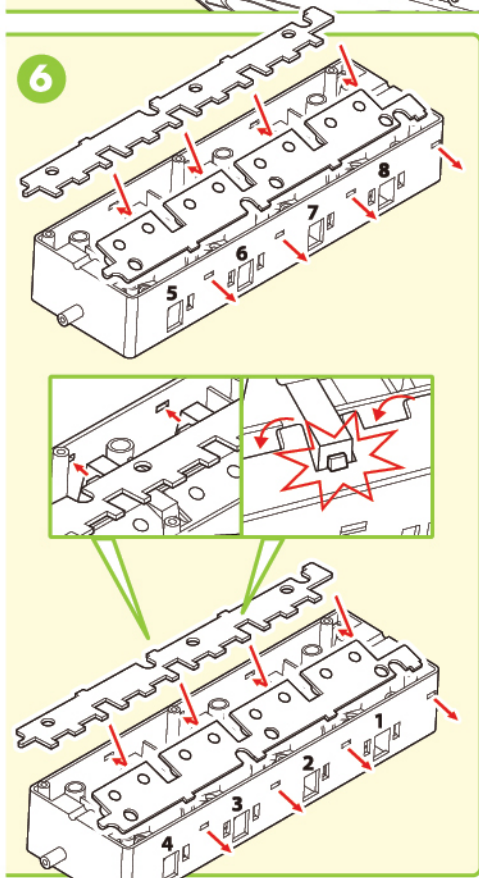
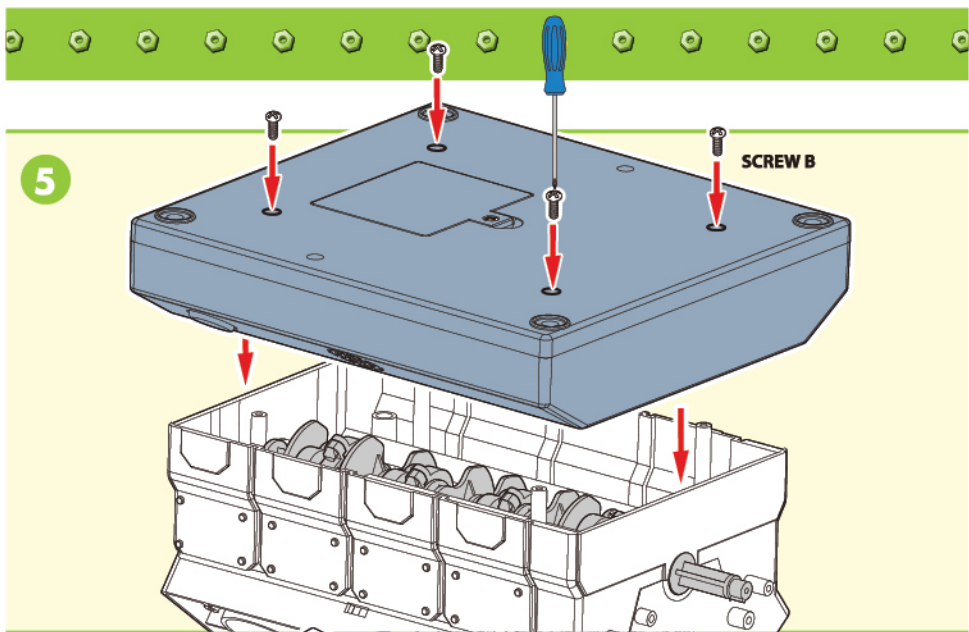



8

Front

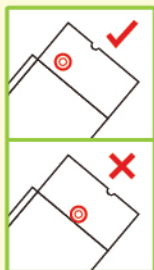

SCREW B

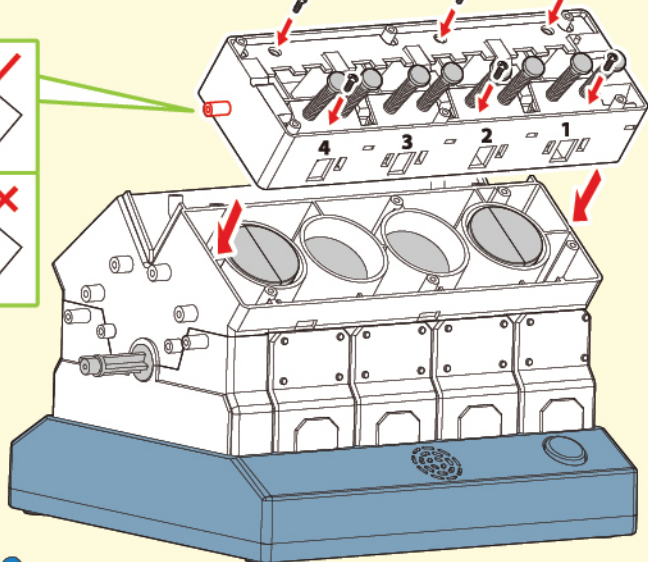

Back



9

Front

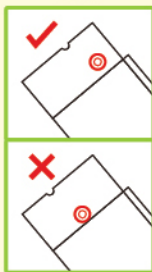

SCREW B

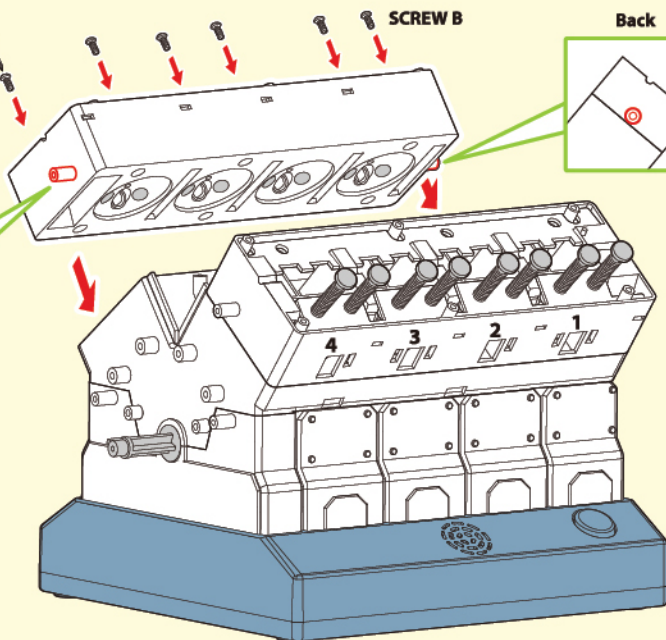

Back





10

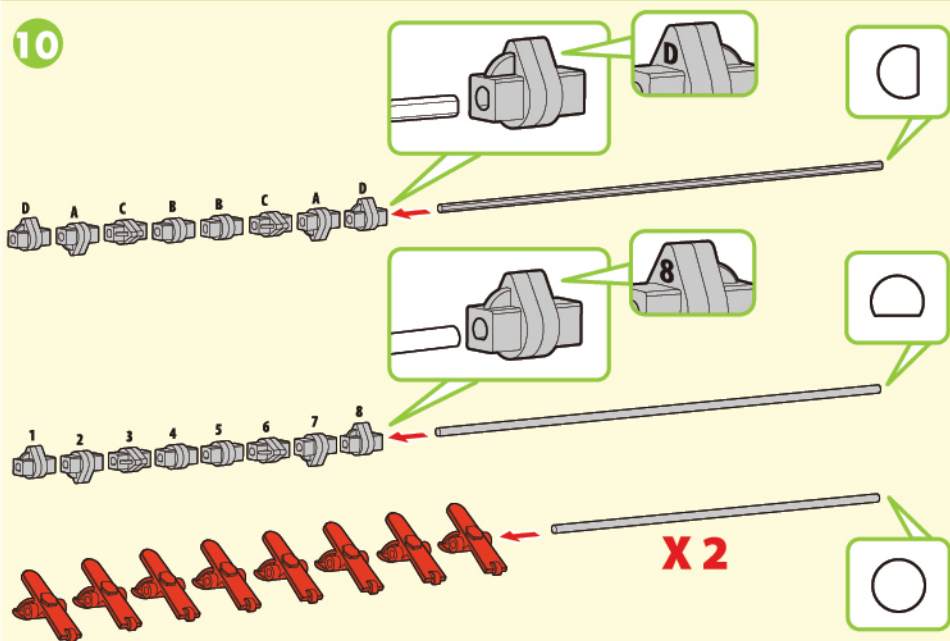

11

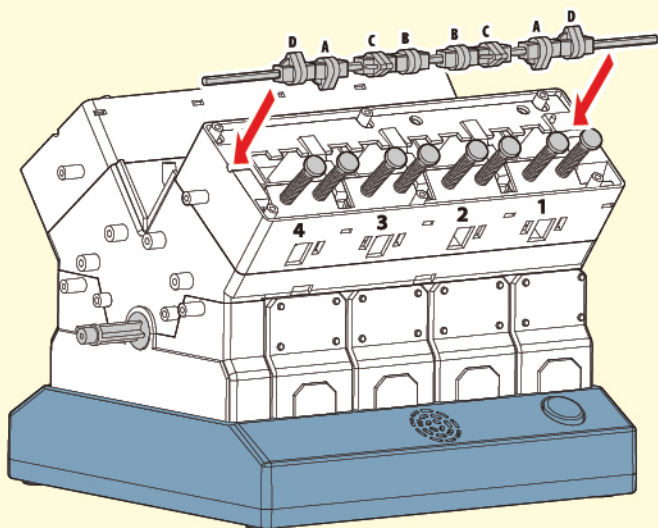

12

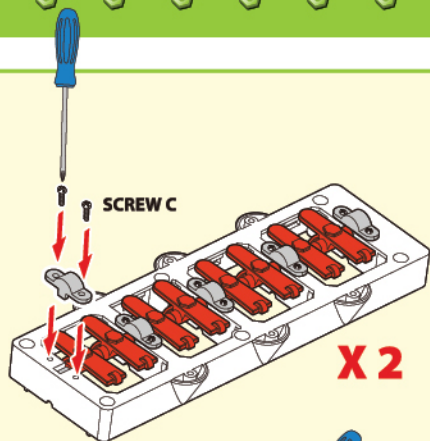
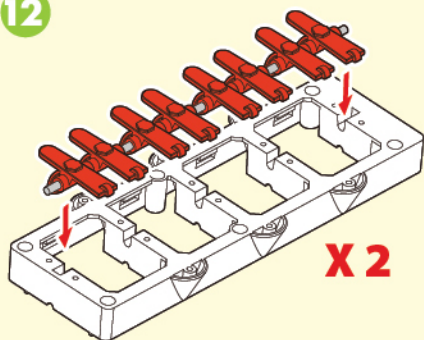

13

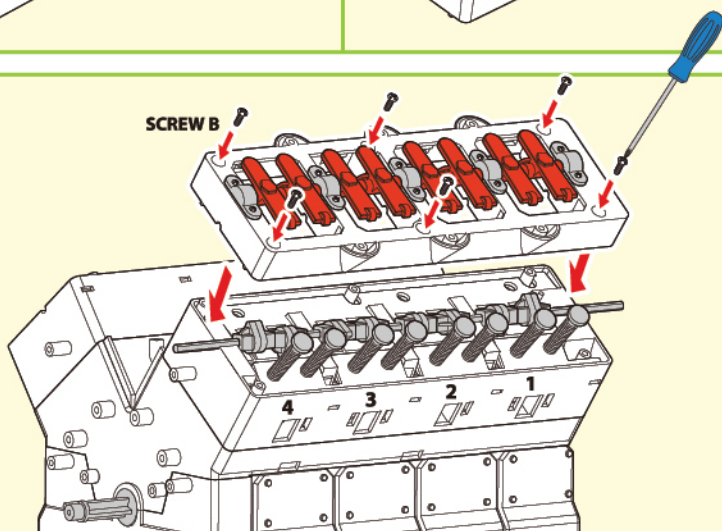

14

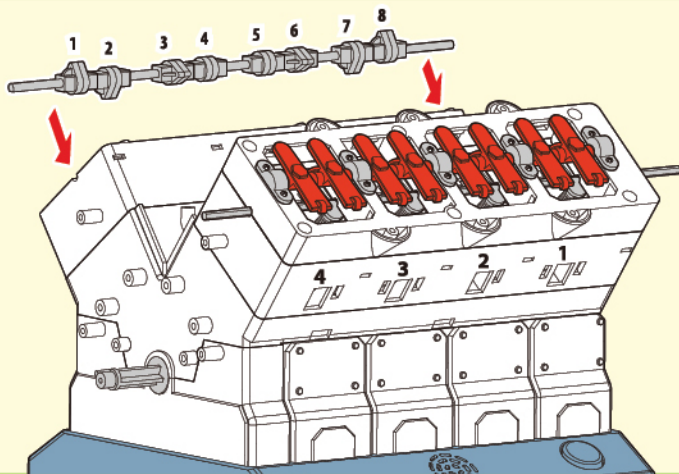

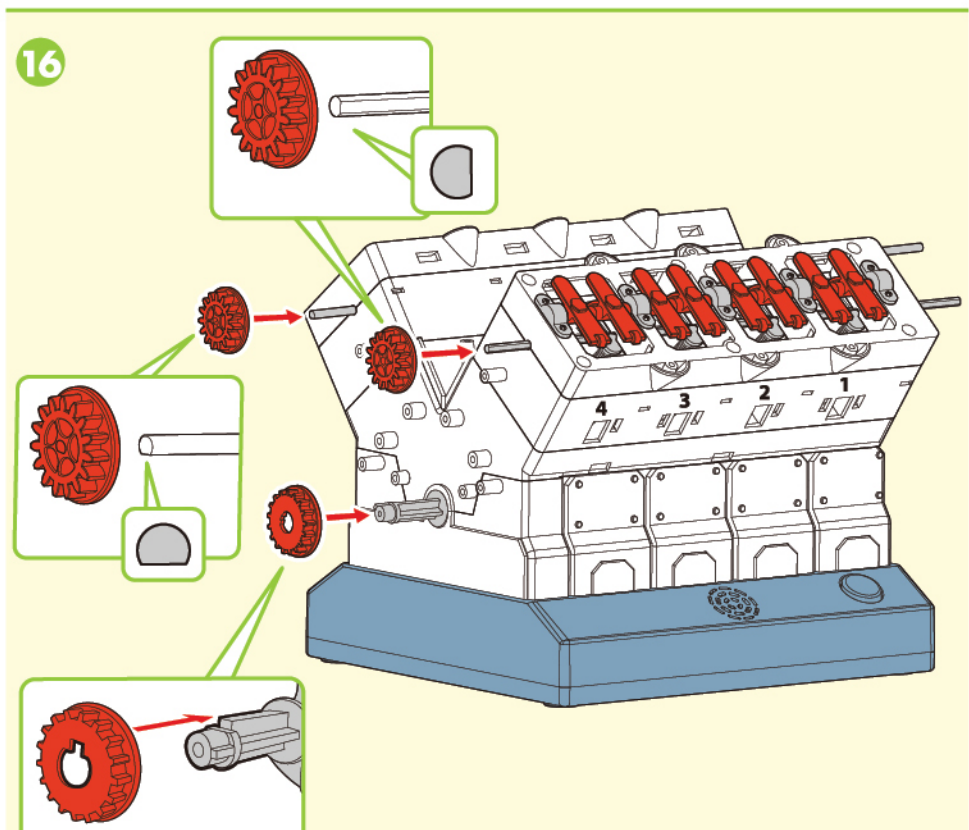
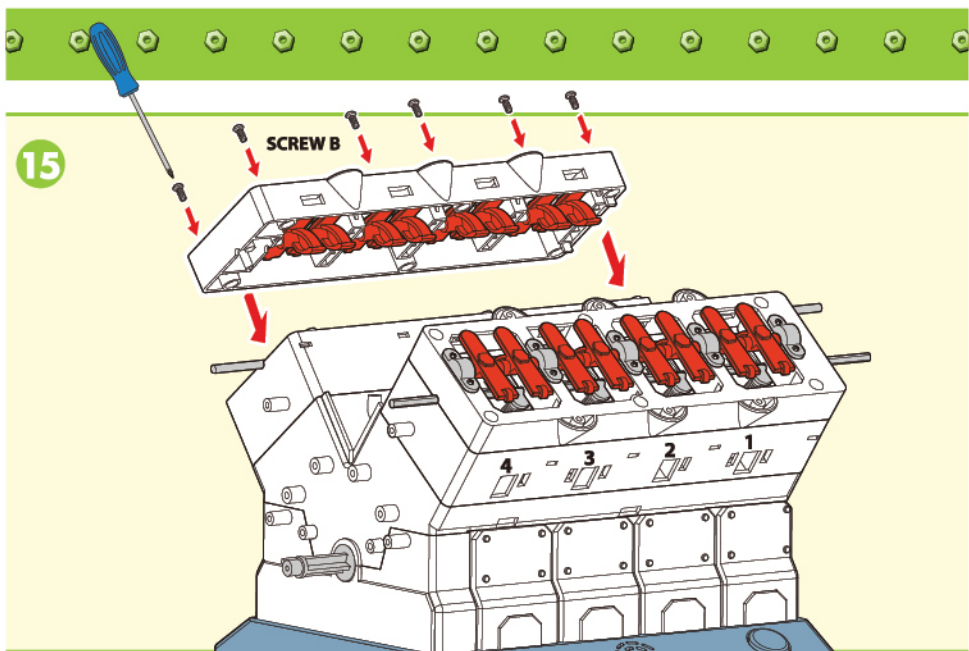

17

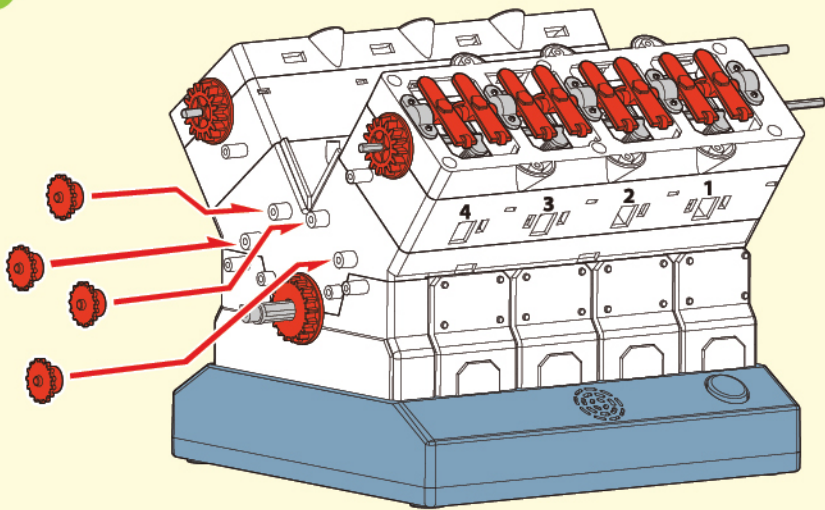

18

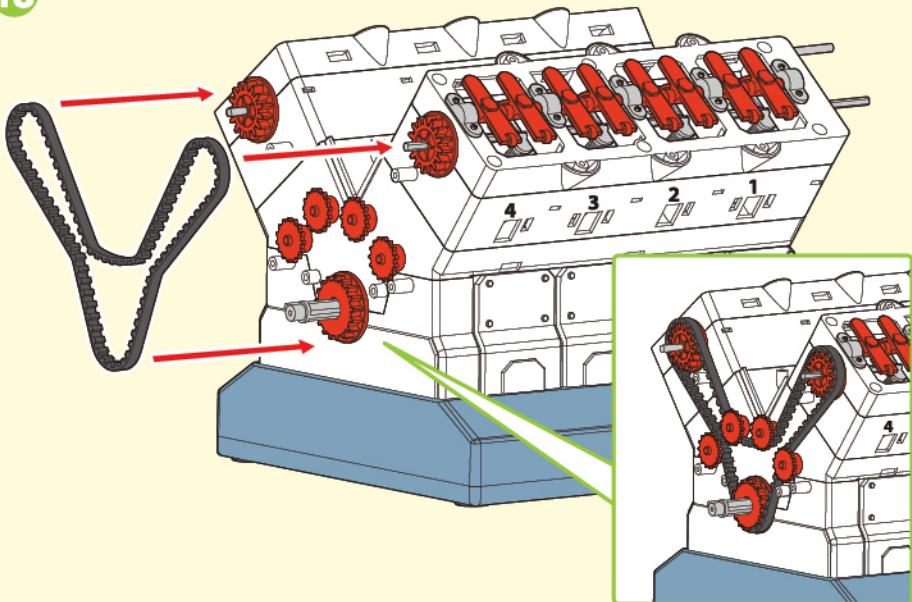

19

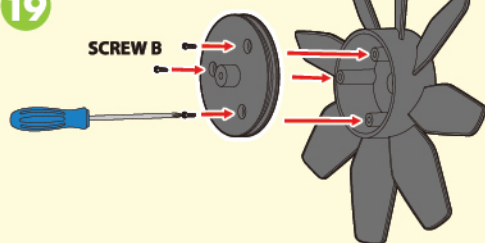

20

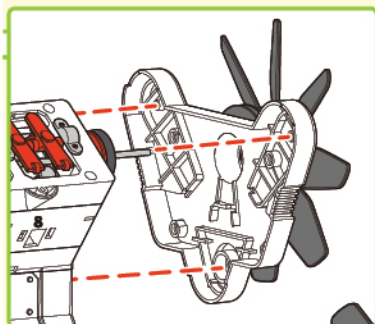
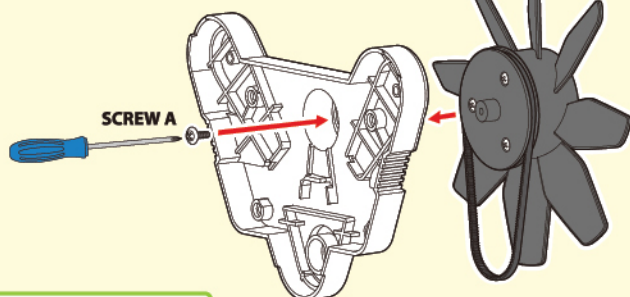

21

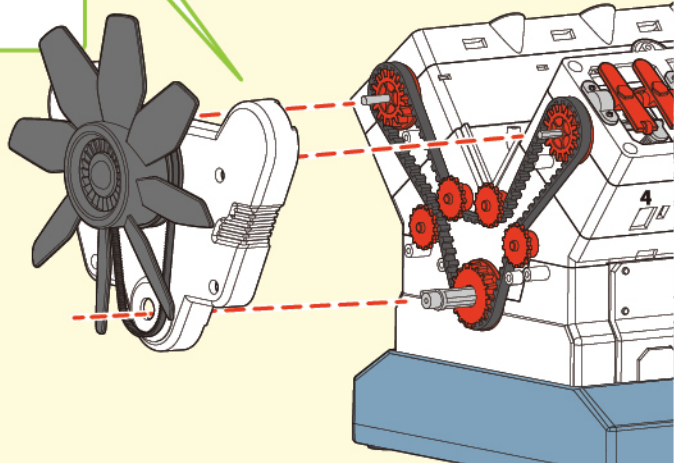

22

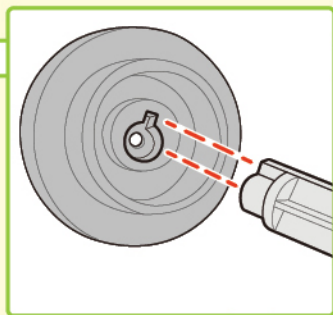
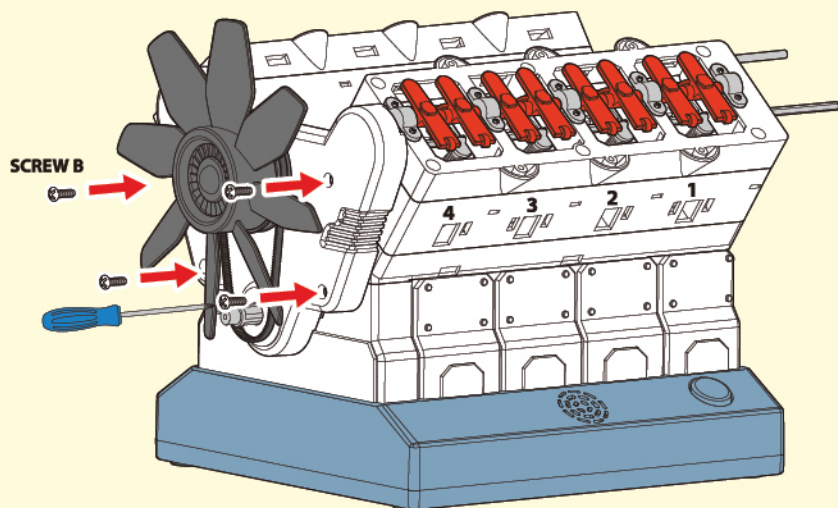

23

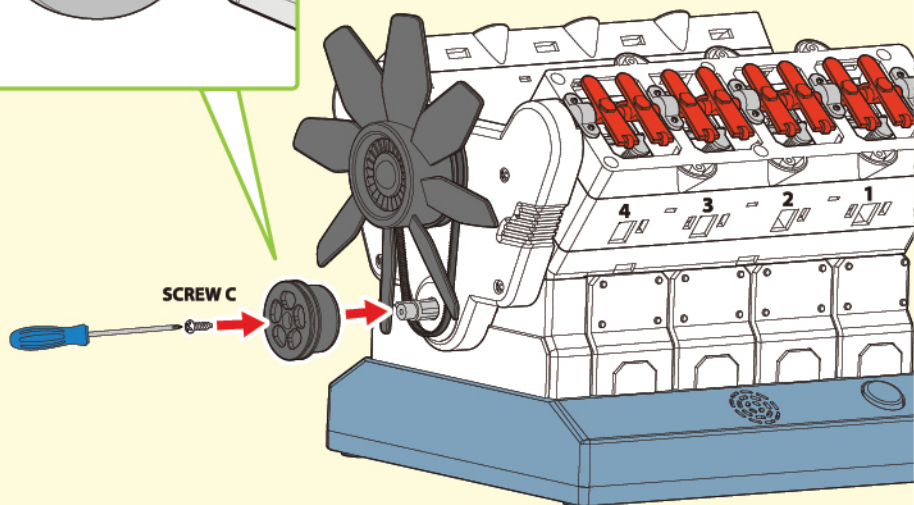

24

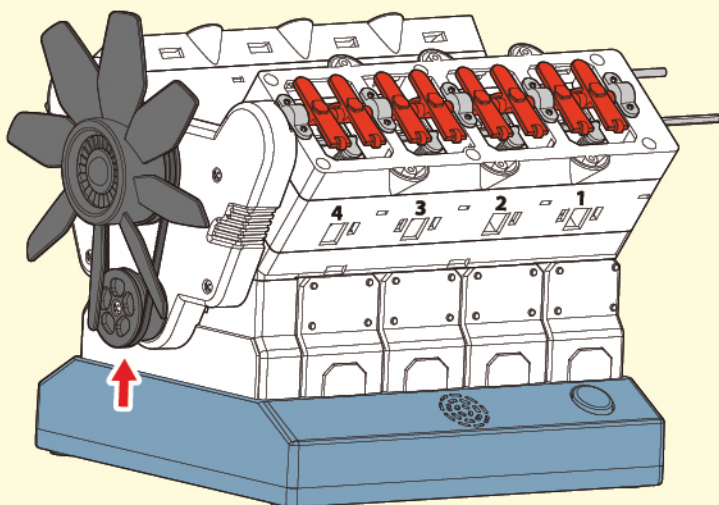

25

Please adjust the hole direction by screwdriver, the hole inner shape should match with the metal pole head shape.

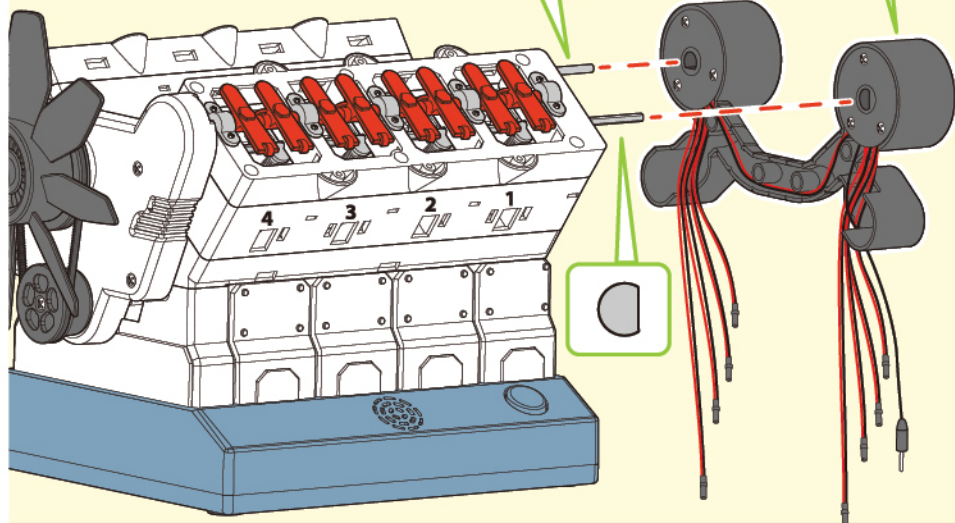
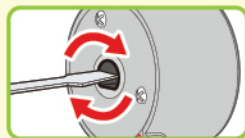

26

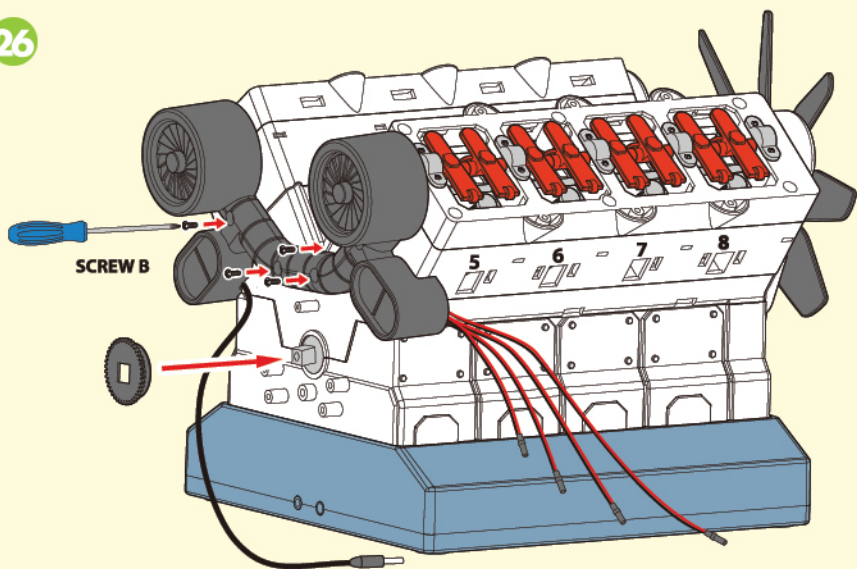

27

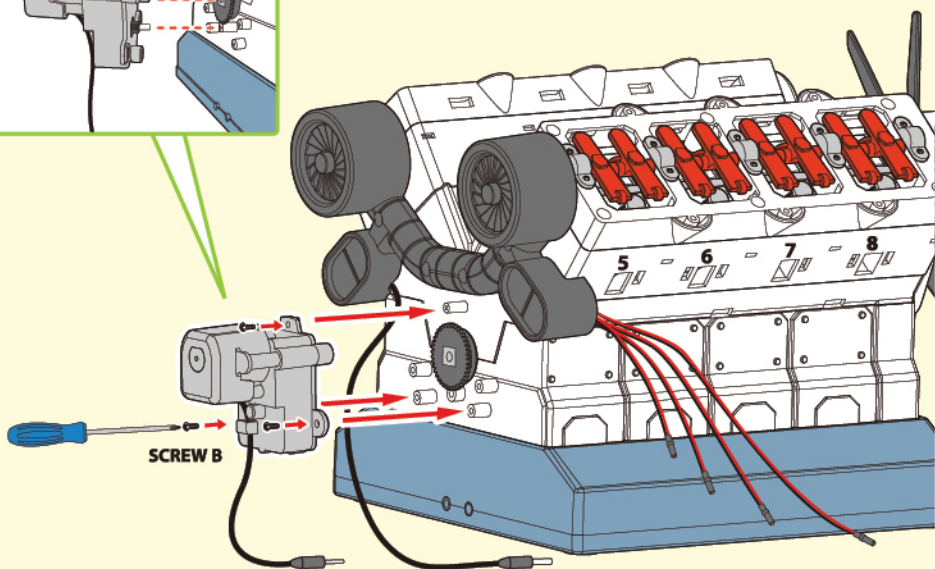
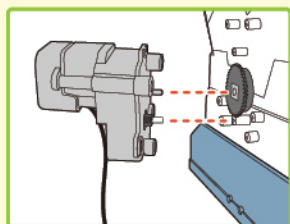

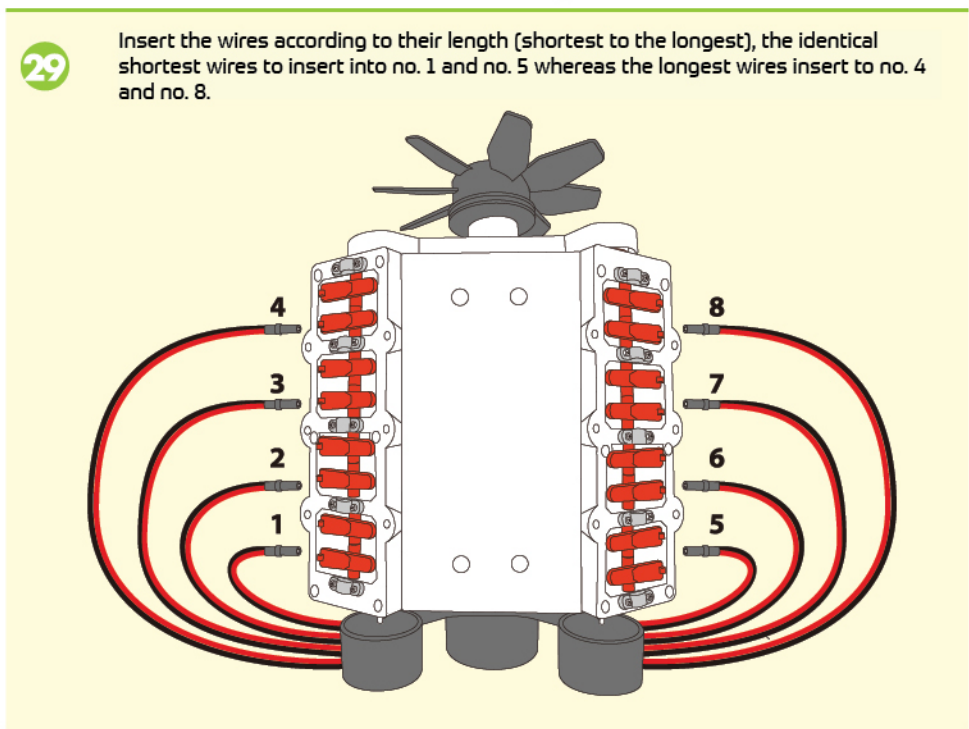
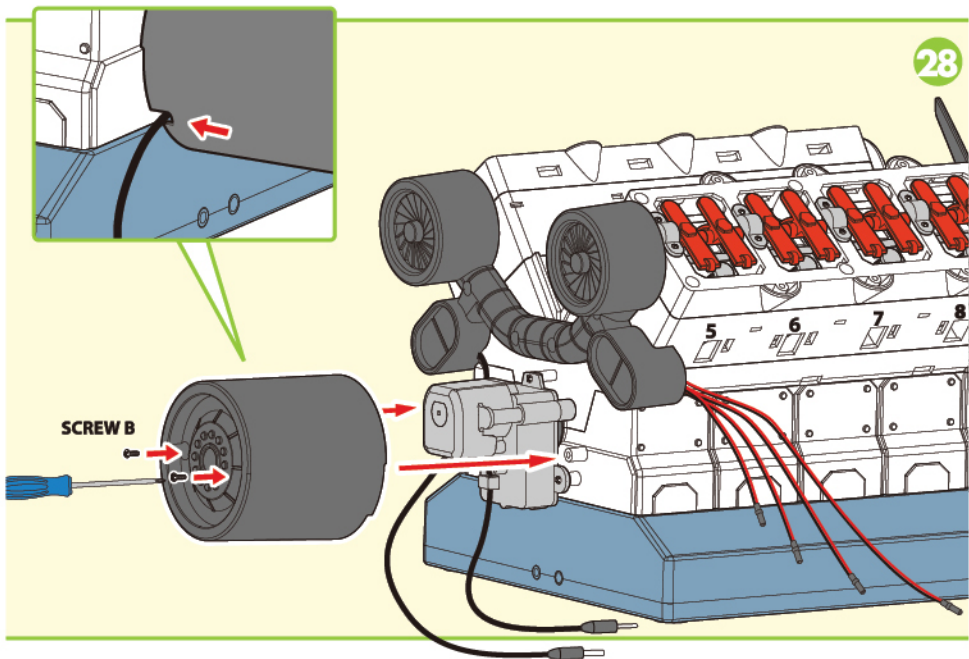

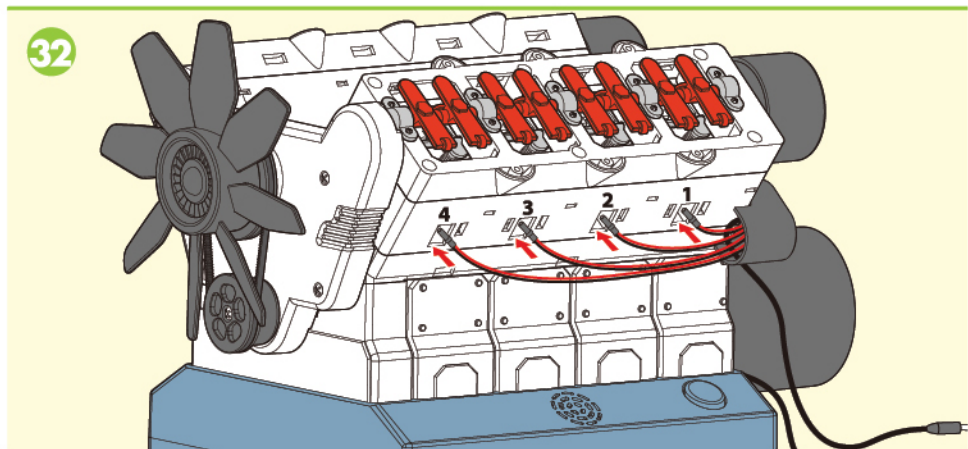
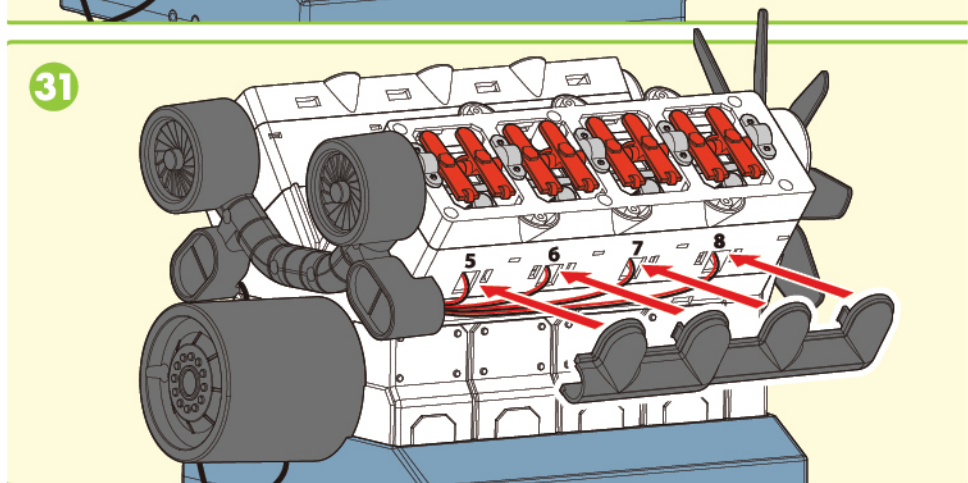
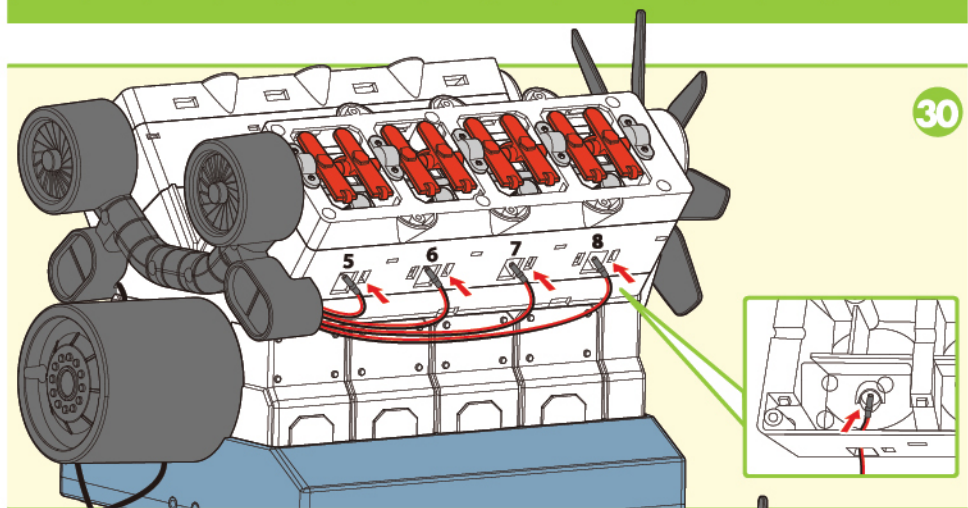

33

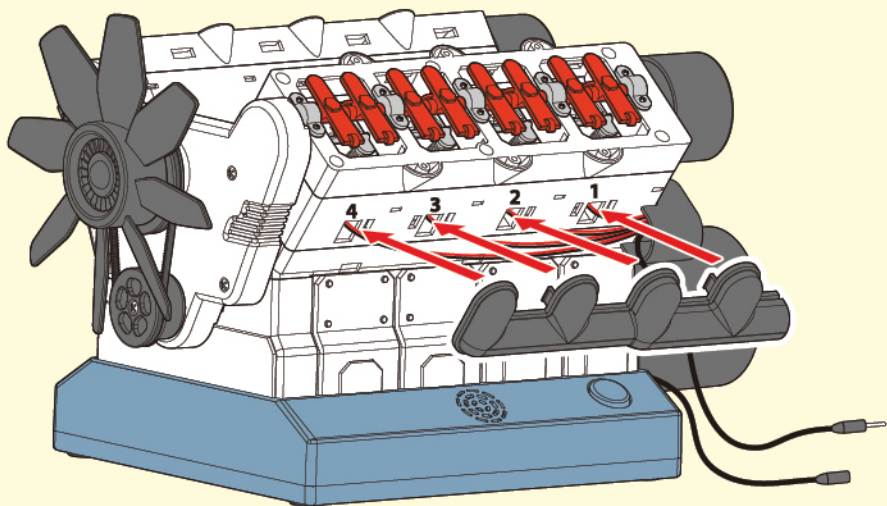

34

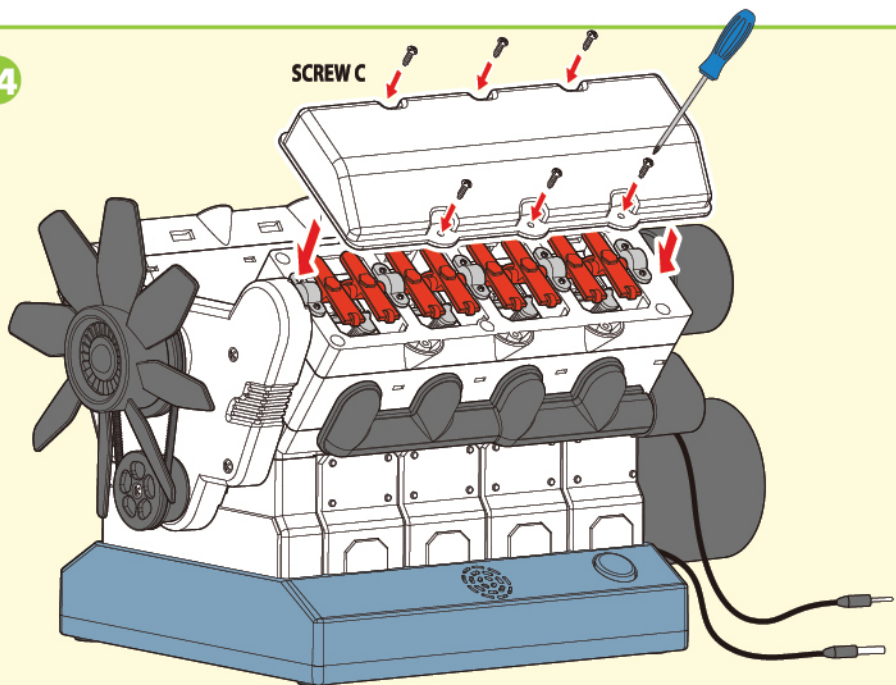

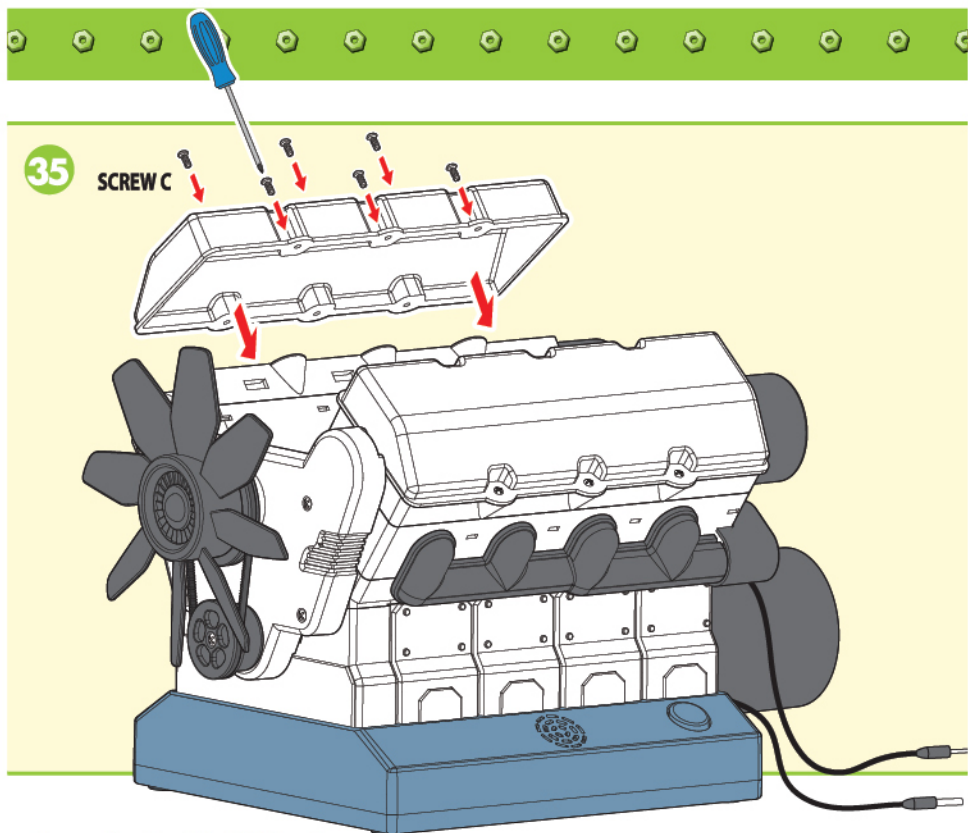

35 SCREW C

Start the V8 Model Engine

Turn the engine upside down. Remove cover by using screw driver and insert 3 AA batteries with the correct polarity as shown. Cover the battery compartment and tighten the screw.

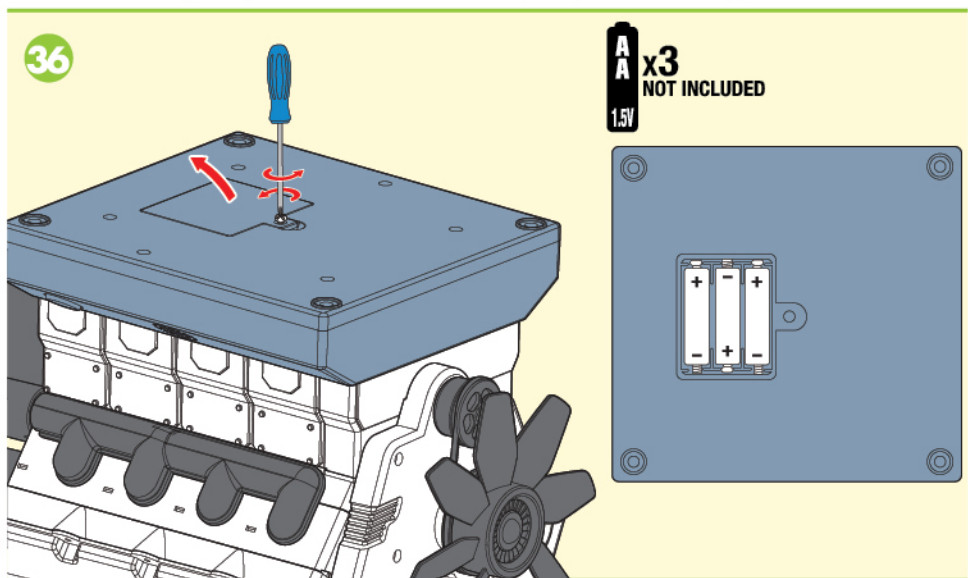

36

AA
x3
1.5V
NOT INCLUDED

37

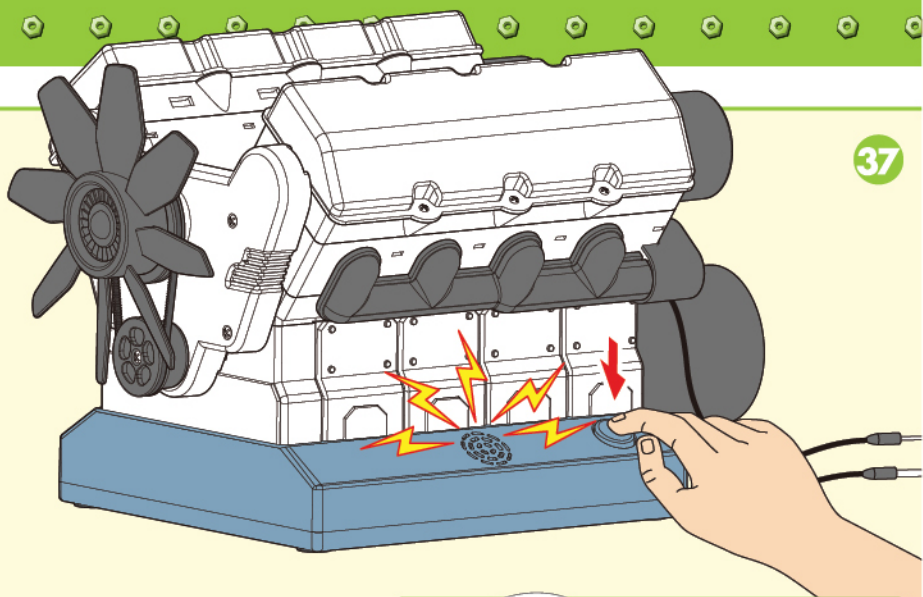

38

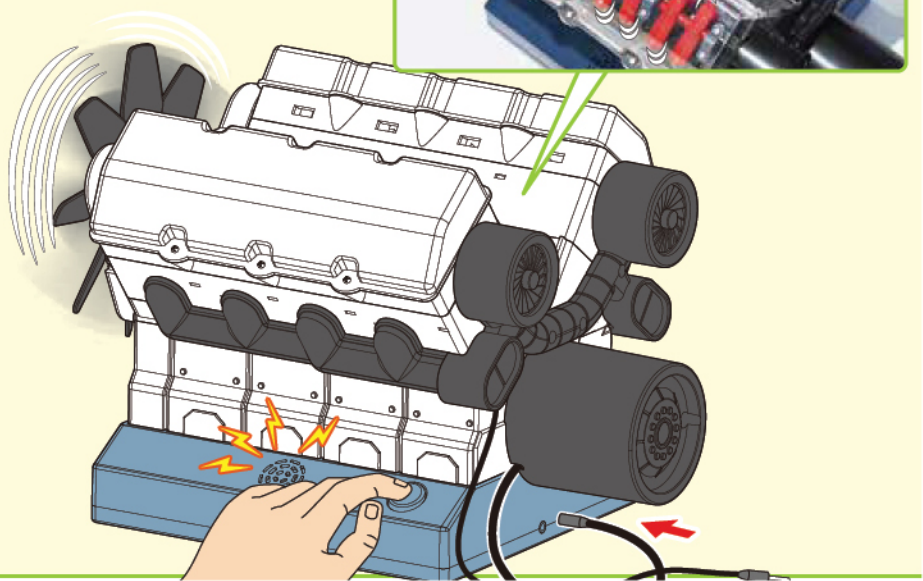

39

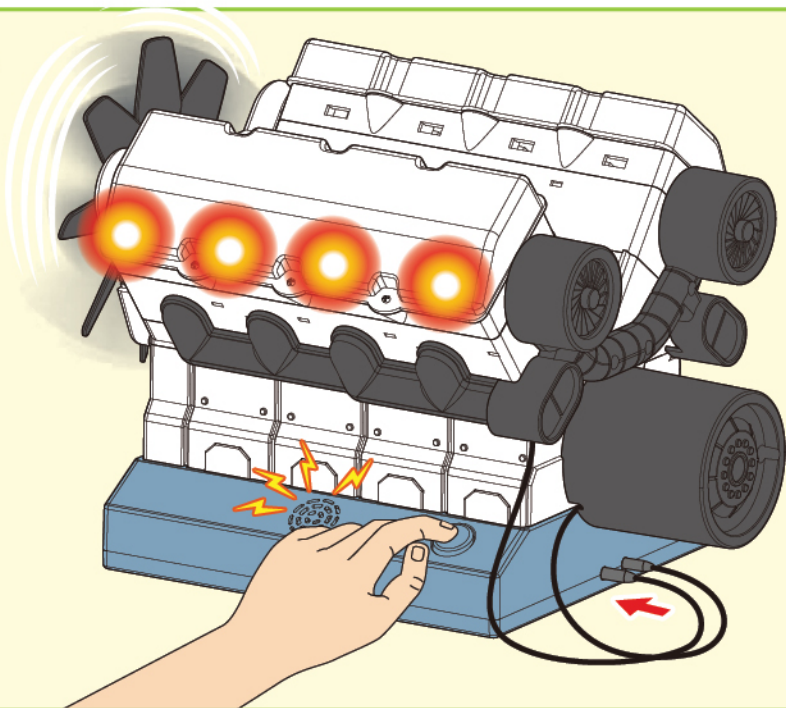

40

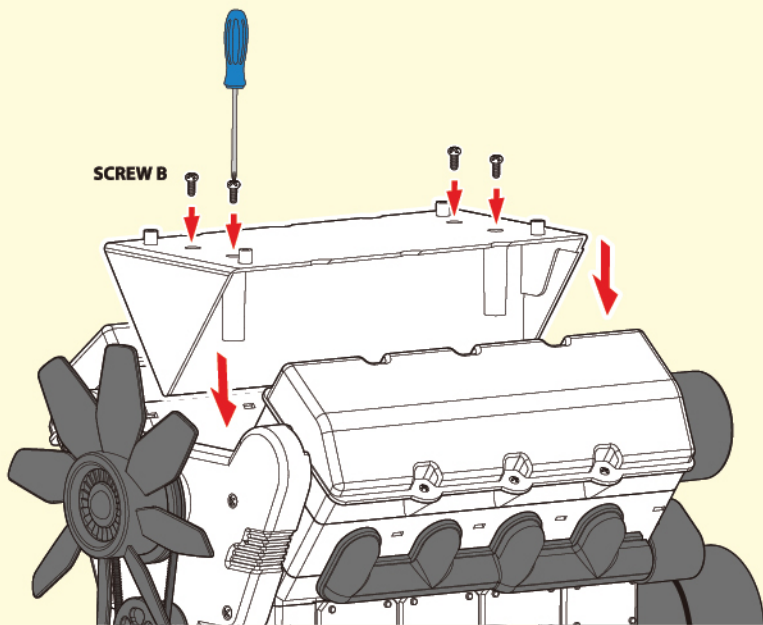

41

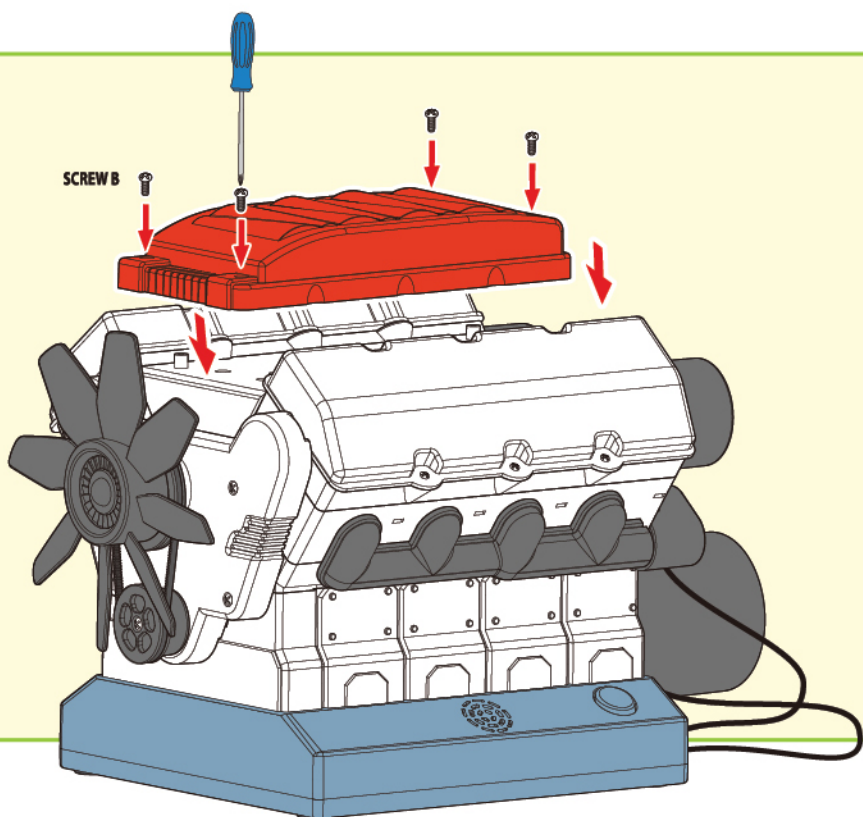

How It Works

When you pressed the start button, the model works, stimulating the 4-stroke-cycle and the engine sound. In this model, the crankshaft is cranked by a motor. When a bulb lights up, it represents the power cycle that the air-fuel mixture is combusted. The inlet and exhaust valves will automatically open and close at the proper time, in phase with the cycle that it is undergoing. The sound at the bottom of the speaker is simulating the sound when a real V8 engine operates. It will run for about 30 secs and goes off.

Comparison

This model is a simulation of the real engine. In a real engine, the combustion of air-fuel mixture in the cylinders is the power source that cranks the crankshaft. In this model, the crankshaft is cranked by the motor to simulate the action. Also, a real engine is made of metal, so that it can withstand the combustion process. Since the combustion will generate lots of heat, a cooling system is required to avoid the engine from overheating. Water is used as a coolant to circulate around the engine to the "radiator" at the front part of the car. Because the combustion process will produce exhaust gas, this is why the engine in a car needs an exhaust pipe--- to exhale the exhaust gas.

If at any time in the future you should need to dispose of this product please note that waste electrical products should not be disposed of with household waste. Please recycle where facilities exist. Check with your local authority or retailer for recycling advice. (Waste Electrical and Electronic Equipment Directive)



©2020 Explore Scientific, LLC.
1010 S 48th Street, Springdale, AR 72762
explorescientificusa.com | 866.252.3811
All rights reserved. Made in China.

CONTENTS AND COLORS MAY VARY
CONFORMS TO THE SAFETY REQUIREMENTS OF ASTM F963