



AGES
8+

#88-90147



ELECTRONIC 72+ SCIENCE WORKSHOP SET

USER MANUAL



**x4
NOT INCLUDED**

Do not mix old and new batteries. Do not mix alkaline, standard (carbon-zinc), or rechargeable (ni-cad, ni-mh, etc.) batteries. Non-rechargeable batteries are not to be recharged. Please recycle batteries responsibly.



WARNING:

CHOKING HAZARD – Small parts.
Not for children under 3 years.



WARNING:

This product can expose you to chemicals including lead, which is known to the State of California to cause cancer and birth defects or other reproductive harm. For more information go to www.P65Warnings.ca.gov.

ELECTRONIC 72+ SCIENCE WORKSHOP SET

We take pleasure to welcome you to try out this ready-to-use electronic circuit kit suitable for children of 8 years old and up. "You'll be amazed" to find what you can learn as the experiment is a realistic concept of electronics and electricity. It will definitely enable you to learn about the necessary electronic components, circuits, and theories as well as the basic electronics principles – electricity, voltage, current, resistance, magnetism, other electrical circuits and theories.

It is alright if you have no knowledge about electronics and do not fully understand how all the experiments work. Once you get started you will be able to build your understanding through experimenting and maybe trying out some interesting experiments on your own.

This electronic circuit kit contains more than 72 experiments, and it is smartly designed that the main circuit board unit has all the relevant electronic components included. All you have to do is simply connect the wires according to the wiring sequence of each experiment and follow the steps one by one. Once connected the circuit will activate and function.

Remember this is not a one-time experiment. The more you spend on building the experiments the better knowledge you will gain. You will never get bored but totally engaged as you will discover more new exciting experiments for a few years to come.

WARNING : Only for use by children aged 8 years and older. May over heat.

72+ EXPERIMENTS

- Experiment 1- Color filter
- Experiment 2- Color filter in parallel with red LED light
- Experiment 3- Red and green LED light
- Experiment 4- Diode and capacitor charging/discharging
- Experiment 5- LED light
- Experiment 6- Basic circuitry of LED light
- Experiment 7- Timer electric color filter
- Experiment 8- Time-delay electric color filter
- Experiment 9- Sound control color filter
- Experiment 10- Touch-mode color filter
- Experiment 11- Alternate working of LED light and electric color filter
- Experiment 12- Speed-adjustable electric color filter
- Experiment 13- Direction-change indicator
- Experiment 14- Rain indicator
- Experiment 15- LUX indicator
- Experiment 16- Connection indicator
- Experiment 17- Light control stop-and- spin electric color filter
- Experiment 18- Magnet control stop-and- spin electric color filter
- Experiment 19- Manual control stop-and- spin electric color filter
- Experiment 20- Light control extinguish-and-light LED
- Experiment 21- Magnet control extinguish-and-light LED
- Experiment 22- Manual control extinguish-and-light LED
- Experiment 23- Double-Switch control LED light
- Experiment 24- Practical super dimmable LED light
- Experiment 25- Super manual control delayed LED
- Experiment 26- Super magnetic activated delayed LED
- Experiment 27- Touch control delayed extinguishing LED
- Experiment 28- Light control activated LED light
- Experiment 29- Super LED light activated by darkness
- Experiment 30- Light control extinguish-and-light super LED light
- Experiment 31- Adjustable and blow-able super LED light
- Experiment 32- Manual control extinguish-and-light super LED light
- Experiment 33- Water droplet activated simulated motor sound with LED
- Experiment 34- Water droplet activated simulated ship sound with LED
- Experiment 35- Water droplet activated simulated delayed motor sound with LED
- Experiment 36- Magnet control motor dory sound with red LED
- Experiment 37- Magnet control motor dory sound with green LED
- Experiment 38- Magnet control ship sound with LED
- Experiment 39- Magnet control electronic metronome with LED
- Experiment 40- Manual control electronic metronome with LED
- Experiment 41- Manual control motor dory sound with red LED
- Experiment 42- Manual control motor dory sound with green LED
- Experiment 43- Manual control ship sound with LED
- Experiment 44- Manual control delayed motor dory sound
- Experiment 45- Magnet control delayed motor dory sound
- Experiment 46- Manual control metronome
- Experiment 47- Multitone producer

- Experiment 48- Magnet control multitone producer
- Experiment 49- Manual control multitone producer
- Experiment 50- Electronic cicada
- Experiment 51- Light control creaking sound
- Experiment 52- Ship sound
- Experiment 53- Adjustable flashing LED light
- Experiment 54- Magnet control adjustable flashing LED light
- Experiment 55- Morse code training kit
- Experiment 56- Bore some humming
- Experiment 57- Automobile's "di-di" sound
- Experiment 58- Hoofbeat
- Experiment 59- AM radio receiver with mute function
- Experiment 60- Big voice AM radio receiver with volume control
- Experiment 61- Magnet control AM radio receiver with volume control
- Experiment 62- Daylight activated AM radio receiver with volume control
- Experiment 63- Darkness activated AM radio receiver with volume control
- Experiment 64- Big voice FM radio receiver
- Experiment 65- Big voice FM radio receiver with volume control
- Experiment 66- Daylight activated FM radio receiver with volume control
- Experiment 67- Darkness activated FM radio receiver with volume control
- Experiment 68- Big voice AM/FM radio receiver with volume control
- Experiment 69- Simple impact amplifier
- Experiment 70- Magnet control FM radio receiver with volume control
- Experiment 71- Touch control FM radio receiver with volume control
- Experiment 72- FM radio receiver with mute function
- Experiment 73- Magnet control auto-sensor

COMPONENTS IN THIS KIT

Description	Quantity
72 in 1 Circuit Board Unit	1pc
Magnetic pole	1pc
Connecting wire	10cm x 10pcs, 20cm x 10pcs, 30cm x 10pcs, 40cm x 2pcs
Instruction Manual	1pc

WARNING

Adult supervision and assistance is required. This unit is only for use by children aged 8 years and older. Not suitable for children under age 3 years old due to small part(s) and component(s) – CHOKING HAZARD. Read and follow all instructions in the manual before use. This toy contains small parts and functional sharp points on components. Keep away from children under age 3 years. Please retain the information and this manual for future reference. Instructions for parents are included and have to be observed. WARNING! Not intended for children under 8 years. This product contains (a) small magnets(s). Swallowed magnets can stick together across intestines causing serious injuries. Seek immediate medical attention if magnet(s) are swallowed. Warning. Do not use close to the ear! Misuse may cause damage to hearing.

CAUTION!

Before setting up any experiment, please double check and make sure all wiring connections you have made are correct before inserting the batteries and switching on the unit as failure may result in damage to components or circuit board units. When experiment is finished, make sure the batteries are disconnected and switch off the unit before you clear away the wires. Do not apply any components or parts to the experiment other than those provided with this kit. If this product malfunctions or "locks up", try switching off and back on again or removing and re-inserting batteries. Do not lock the motor or other moving parts. Otherwise it may cause overheating. The toy is not to be connected to more than recommended number of power supplies.

BATTERY INFORMATION

To insert batteries please unscrew battery cover with a screw driver. Insert the required batteries in accordance with battery polarity with + and – ends in the right position and then fix screw on the battery cover to close the battery compartment case.

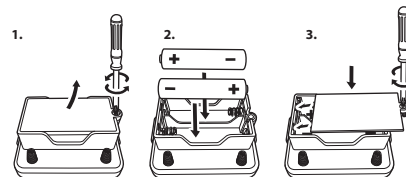

Insert batteries only **after** assembling and wires are connected.

Use 4 x AA size batteries (not included). For best performance, always use fresh batteries and remove batteries when not in use. Batteries must be inserted with the correct polarity. Non-rechargeable batteries are not to be recharged. Re-chargeable batteries are only to be charged under adult supervision. Re-chargeable batteries are to be removed from the toy before being charged. Different types of batteries or new and used batteries are not to be mixed. Exhausted batteries are to be removed from the toy. The supply terminals are not to be short-circuited. Only batteries of the same or equivalent types are to be used. Do not dispose of the batteries in fire. Do not mix old and new batteries Do not mix alkaline, carbon zinc and re-chargeable batteries

WIRING SEQUENCE AND CONNECTION

Ensure all wires are correctly connected to the numbered spring terminals of the main circuit board unit as stated wiring sequence of each experiment.

Bend the spring terminal over and insert the exposed shiny conductor part of wire into spring terminal. Make sure the wire is securely connected to spring terminal.

For example if the wiring sequence is 4-33, 1-10-32-35, 2-12, then connect a wire between spring terminal 4 and 33; and then connect a wire between spring terminal 1 and 10, and a wire between spring terminal 10 and 32, and a wire between spring terminal 32 and 35; and finally connect a wire between spring terminal 2 and 12. This is an example for reference only, not an exact circuit connection in the experiment.

If the circuit does not work, you can check the wire and spring terminal connection whether it is not well connected or insulated plastic part of the wire is inserted to spring terminal.

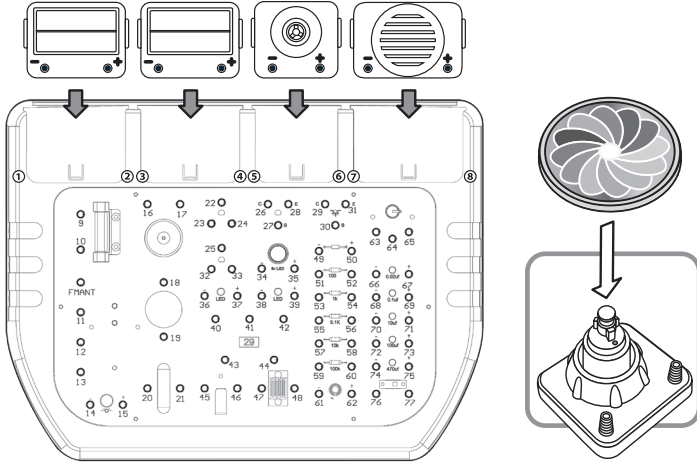

Objective :

The overall aim for this electronic circuit kit is for you to get a better understanding of how connecting different wiring sequence will make different science experiments. Each experiment is targeted at different basic concept of electronics & electricity. Please make sure to read carefully and all wires are correctly connected in the indicated diagram in order to have each experiment work.

Note : Remember to untie the string which ties the flying disc/color filter (if available) to the motor before starting experiment. When the motor is rotating, do not use anything to touch the motor.

Note for Color filter: When installing the color filter onto the motor, make sure the 3 recess areas at the bottom of the color filter fit to the top of the motor properly. You may need to fiddle with the color filter a bit until you see the 3 recess areas are fitted to the 3 protrusions on the top end of the motor. In case of improper installing, the color filter may flap off in operation and cause harm.

Experiment 1

Color filter

Wiring Sequence 2-6, 5-77, 76-1

- Complete all wiring connections as indicated in the sequence. By switching ON, the color filter will be activated for rotating.

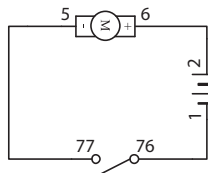

Experiment 2

Color filter in parallel with red LED light

Wiring Sequence 2-6-52, 51-39, 1-76, 5-77-38

- Complete all wiring connections as indicated in the sequence. By switching ON, the color filter will rotate, and red LED will light up; By switching OFF, the color filter will stop, and red LED will extinguish.

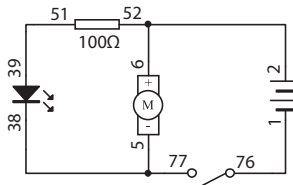

Experiment 3

Red and green LED light

Wiring Sequence 2-52, 51-37-39, 1-76, 77-36-38

- Complete all wiring connections as indicated in the sequence. By switching ON, both red LED and green LED will light up. By switching OFF, both LED will extinguish.

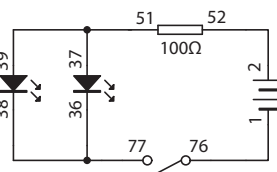

Experiment 4

Diode and capacitor charging/discharging

Wiring Sequence 2-76, 50-51-77, 75-49-45, 39-46, 37-52, 1-36-38-74

- Complete all wiring connections as indicated in the sequence. By switching ON, green LED will light up, and the capacitor will be charged. By switching OFF, green LED will extinguish. And then press the push switch. Capacitor will discharge to red LED and make it bright for a while. When the discharge ends, the capacitor has used up stored electricity and thus red LED will extinguish.

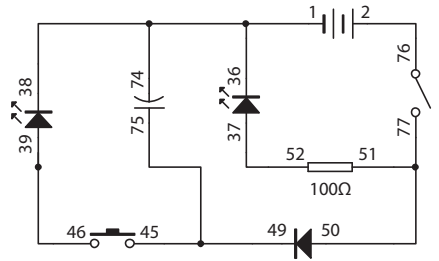

Experiment 5

LED light

Wiring Sequence 2-3, 4-35, 34-77, 1-76

- Complete all wiring connections as indicated in the sequence. By switching ON, LED will light up. By switching OFF, the LED will extinguish.

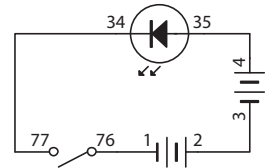

Experiment 6

Basic circuitry of LED light

Wiring Sequence 1-34, 2-3, 35-38-46, 45-39-77, 4-76

- Complete all wiring connections as indicated in the sequence. By switching ON, both red LED and large green LED will light up. When pressing on the push switch, red LED will extinguish, but large green LED will keep on glowing. This circuitry can be used for switching between weak light and strong light.

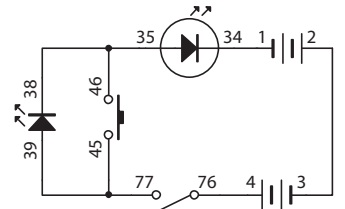

Experiment 7

Timer electric color filter

Wiring Sequence 2-29-45, 30-28, 27-58, 73-57-46, 6-31, 1-77, 5-26-72-76

- Complete all wiring connections as indicated in the sequence. By switching ON and pressing the push switch, the color filter will spin. At the same time, the capacitor will be charged. When the push switch is released, the circuit is disconnected, but the color filter will still keep on spinning for a while. This is because the capacitor will discharge and release its stored electricity, thus the color filter will still spin for a while.

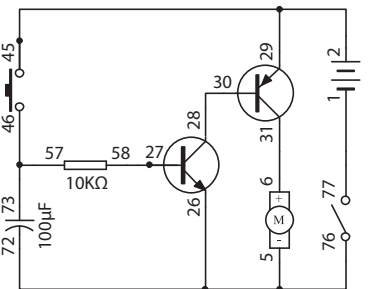

Experiment 8

Time-delay electric color filter

Wiring Sequence 2-60-29, 28-30, 65-59, 27-64, 63-73, 72-5-26-76, 6-31, 1-77

- Complete all wiring connections as indicated in the sequence. After switching ON for a time period, the color filter will start to spin. This delay is due to the charging of the capacitor. During the charging, the base electrode of the transistor is in a low voltage so that the transistor is shut. When the capacitor is charged fully, the transistor is in its conducting condition, thus the color filter will spin. The time-delay period is the duration of the charging.

NOTE: Every time when you perform this experiment once, remember to "discharge" the capacitor before doing it again. Otherwise it won't work properly. To "discharge", connect any wire to 72-73 for a second. This way the electricity stored in the capacitor will be "discharged" and then the experiment can work properly again.

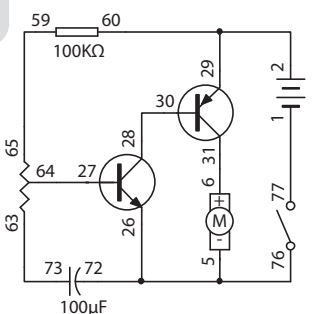

Experiment 9

Sound control color filter

Wiring Sequence 3-76, 4-33-51-54-15, 32-6, 64-49-25, 52-65, 28-50-53, 27-58-14, 5-26-57-63-77

- Complete all wiring connections as indicated in the sequence. Adjust the variable resistor to the minimum value. Then switch on the main switch. Step by step, adjust the variable resistor slowly and try to blow to the microphone. You will find a point which the color filter will only be triggered by your blowing to spin. This is the desired setting for this experiment. Now you can clap loudly near the microphone, or make a deep blow to the microphone, or get close to the microphone and speak loudly towards it to trigger the color filter to spin.

WARNING: Do not let the color filter keep on spinning non-stop, as color filter keeps on spinning may cause components to overheat in this experiment. So remember to switch off the main switch to stop the the color filter.

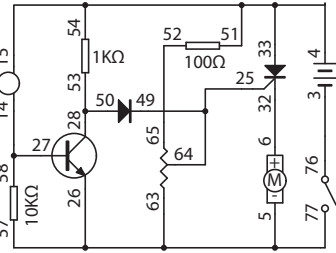

Experiment 10

Touch-mode color filter

Wiring Sequence 2-29-48, 47-27, 28-30, 6-31, 1-77, 5-26-76

- Complete all wiring connections as indicated in the sequence. Switch on the main switch and touch the touching-plate with your finger. The circuit will be connected and the color filter will begin to spin. If touching the touching-plate does not show anything, dampen your finger with water before touching will make it work. And remember to wipe the water off the touch plate after you remove your finger from it.

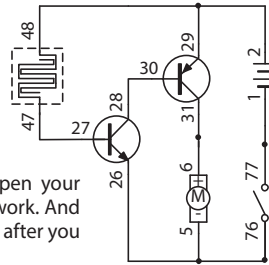

Experiment 11

Alternate working of LED light and electric color filter

Wiring Sequence 2-29-51-50, 49-37, 1-77, 52-65, 28-30, 27-64-75, 74-36-31-6, 5-26-63-76

- Complete all wiring connections as indicated in the sequence. Switch on the main switch and adjust the variable resistor slowly to a suitable position. LED and electric color filter will work alternately. The frequency of the alternation can be changed according to the adjusting of the variable resistor. Adjusting the variable resistor to its maximum, the electric color filter will spin and LED will extinguish. Adjusting the variable resistor to its minimum, the electric color filter will stop and LED will light up.

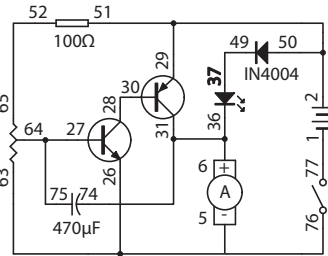

Experiment 12

Speed-adjustable electric color filter

Wiring Sequence 2-29-56, 55-65, 64-27, 28-30, 6-26-31, 1-77, 5-76-63

- Complete all wiring connections as indicated in the sequence. Switch on the main switch. Adjust the variable resistor slowly. This will change the control voltage of the transistor. Thus the spinning speed of the color filter will change. Utilizing this principle can get a speed-adjustable electric color filter.

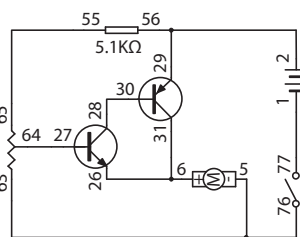

Experiment 13

Direction-change indicator

Wiring Sequence 1-76, 65-39-28-2, 77-31-36-63, 64-55, 56-30-27, 26-29-37-38

- Complete all wiring connections as indicated in the sequence. Switch on the main switch. Turn the variable resistor to minimum. Red LED will light up and green LED will extinguish. Turn the variable resistor to maximum. Green LED will light up and red LED will extinguish. This principle can be used for indicating the change of direction of automobile, as different direction will cause different LED to light up and extinguish.

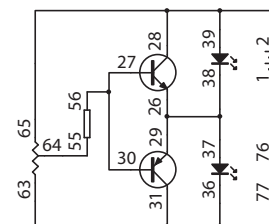

Experiment 14

Rain indicator

Wiring Sequence 2-76, 77-48-39-52, 47-27, 51-38-37-28, 1-26-36

- Complete all wiring connections as indicated in the sequence. Switch on the main switch. Drop a drop of water on the touch-plate, then red LED will light up and green LED will extinguish. Wipe the water off the touch-plate. Then green LED will light up and red LED will extinguish. This circuit can be used for rain indicating or water-level warning. When it rains or water-level goes beyond warning level, red LED will light up, green LED will extinguish. Otherwise red LED will extinguish and green LED will light up.

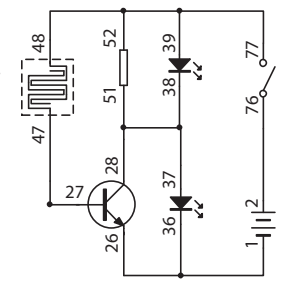

Experiment 15

LUX indicator

Wiring Sequence 2-76, 77-62-37-52, 61-59-27, 51-39-36-28, 1-26-38-60

- Complete all wiring connections as indicated in the sequence. Switch on the main switch. Green LED will light up while red LED will not. Shade the Light Sensor a little bit, green LED will become dimmer. Shade the Light Sensor a bit more, then green LED will extinguish and red LED will start to light dimly. When the Light Sensor is covered completely, green LED will extinguish and red LED will light up completely. This principle can be used as light indicator, to reflect the amount of light shining on the indicator.

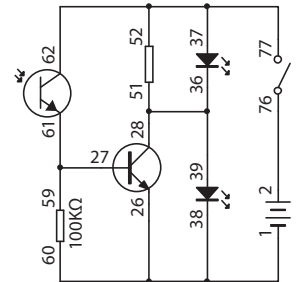

Experiment 16

Connection indicator

Wiring Sequence 2-76, 77-58-39-52, 46-59-27, 51-38-37-28, 1-26-36-60, 45-57

- Complete all wiring connections as indicated in the sequence. Switch on the main switch. Green LED will light up and red LED extinguish. Press the push switch. Red LED will light up and green LED extinguish. This principle can be used for indicating the break/connect of circuit: When the door, car-door or window is closed, this is just like the push switch is being pressed, and thus red LED lights up while green LED does not. When the door, car-door or window is opened, this is just like the push switch is released, and thus green LED lights up while red LED does not.

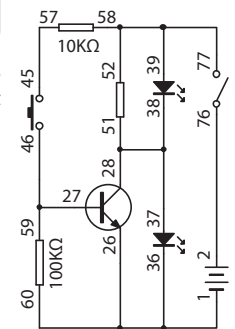

Experiment 17

Light control stop-and- spin color filter

Wiring Sequence 1-76, 6-31, 62-60-29-2, 28-30, 27-72-59, 61-58-73, 5-26-57-77

- Complete all wiring connections as indicated in the sequence. Switch on the main switch, then the color filter will spin. Now cover the light sensor completely. The color filter will stop spinning for a while. However, after keeping on covering the light sensor for a time period, the color filter will suddenly start to spin again! If you uncover the light sensor, then the color filter will spin even faster for a while! After some time, the spinning speed will gradually be back to normal. Covering the light sensor again will stop the spinning again and the process mentioned above can be repeated.

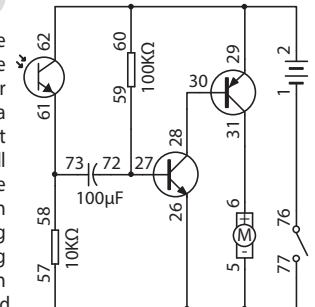

Experiment 18

Magnet control stop-and- spin electric color filter

Wiring Sequence 1-76, 6-31, 60-29-21-2, 28-30, 27-72-59, 20-58-73, 5-26-57-77

- Complete all wiring connections as indicated in the sequence. Switch on the main switch, then after a while the color filter will spin. Access the reed switch with the magnetic pole. The spinning speed will be changed for a while, and gradually back to the original spinning speed. Remove the magnetic pole, and then the spinning will stop for a while. After waiting for some time, the spinning will resume again like it did at the beginning of the experiment!

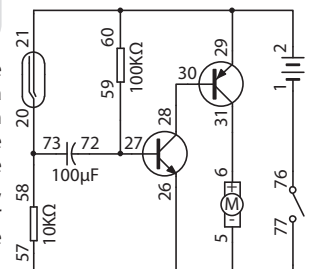

Experiment 19

Manual control stop-and-spining electric color filter

Wiring Sequence 1-76, 6-31, 45-60-29-2, 28-30, 27-72-59, 46-58-73, 5-26-57-77

- Complete all wiring connections as indicated in the sequence. Switch on the main switch. After a while the color filter will spin. Press the push switch, and the spinning speed will be changed for a while. Do not release the push switch, and the speed will gradually back to the original spinning speed. And then release the push switch. The spinning will stop for a while. After waiting for some time, the spinning will resume again like it did at the beginning of the experiment!

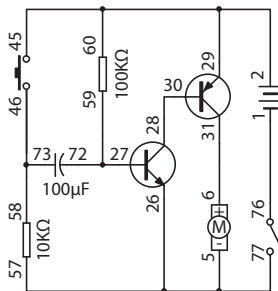

Experiment 20

Light control extinguish-and-light LED

Wiring Sequence 1-76, 37-39-31, 62-60-29-2, 28-30, 27-72-59, 61-58-73, 26-52-57-77, 51-38-36

- Complete all wiring connections as indicated in the sequence. Switch on the main switch. LED will light up. Then cover the light sensor completely. LED will extinguish. Do not uncover the light sensor and wait. After a while, LED will light up again! And then if you uncover the light sensor, the status will be just like the beginning of the experiment. You can repeat the experiment without switching off the main switch.

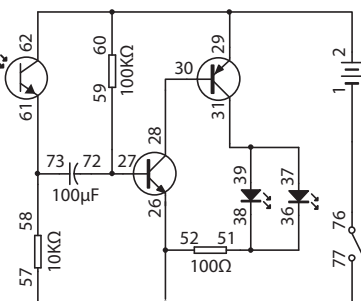

Experiment 21

Magnet control extinguish-and-light LED

Wiring Sequence 1-76, 37-39-31, 21-60-29-2, 28-30, 27-72-59, 20-58-73, 26-52-57-77, 51-38-36

- Complete all wiring connections as indicated in the sequence. Switch on the main switch. LED will light up. Use the magnetic pole to access the reed switch, and then remove the magnetic pole. LED will extinguish. Then wait for a time period, LED will light up again! You can repeat the experiment without switching off the main switch.

NOTE: Every time when you perform this experiment once, remember to "discharge" the capacitor before doing it again. Otherwise it won't work. To "discharge", connect any wire to 72-73 for a second. This way the electricity stored in the capacitor will be "discharged" and then the experiment can work again.

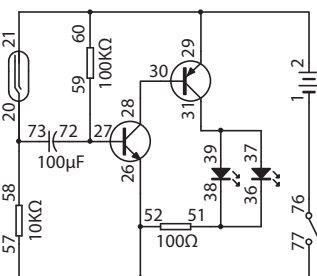

Experiment 22

Manual control extinguish-and-light LED

Wiring Sequence 1-76, 37-39-31, 45-60-29-2, 28-30, 27-72-59, 46-58-73, 26-52-57-77, 51-38-36

- Complete all wiring connections as indicated in the sequence. Switch on the main switch. LED will light up. Press the push switch, and then release it. LED will extinguish. Then wait for a time period, LED will light up again! You can repeat the experiment without switching off the main switch.

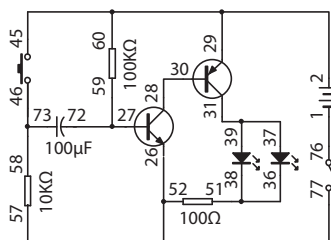

Experiment 23

Double-Switch control LED light

Wiring Sequence 1-76, 2-3, 4-33-46-53, 38-34-77, 32-35, 45-57, 25-58, 54-39

- Connect all wiring connections as indicated in the sequence. Switch on the main switch. Red LED will light up while green LED will not. Then press the push switch. The green LED will also light up.

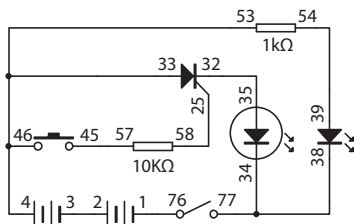

Experiment 24

Practical super dimmable LED light

Wiring Sequence 1-76, 2-3, 4-29-56, 55-65, 27-64, 35-31, 30-28, 26-34-63-77

- Complete all wiring connections as indicated in the sequence. Switch on the main switch. Adjust the variable resistor from minimum to maximum, and the brightness of the LED will change from dim to bright.

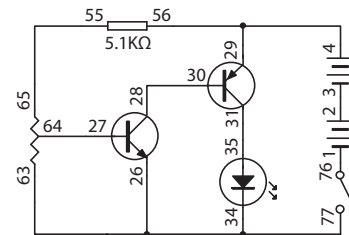

Experiment 25

Super manual control delayed LED

Wiring Sequence 1-76, 2-3, 4-29-45, 73-58-46, 57-27, 30-28, 31-35, 26-34-72-77

- Complete all wiring connections as indicated in the sequence. Switch on the main switch and press the push switch. Electricity will flow through the transistor so that LED will light up. At the same time the capacitor is being charged. Release the push switch. The transistor can still keep conductive for some time, as the capacitor will release the stored electricity. Therefore the LED will not extinguish immediately after you release the push switch.

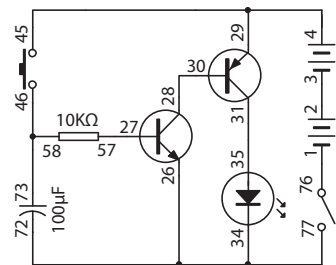

Experiment 26

Super magnetic activated delayed LED

Wiring Sequence 1-76, 2-3, 4-29-20, 73-58-21, 57-27, 30-28, 31-35, 26-34-72-77

- Complete all wiring connections as indicated in the sequence. Switch on the main switch. Use the magnetic pole to access the reed switch. The circuit is connected and LED will light up. At the same time the capacitor is being charged. Remove the magnetic pole. The transistor can still be conductive for some time, as the capacitor will release the stored electricity. Therefore the LED will not extinguish immediately after you remove the magnetic pole.

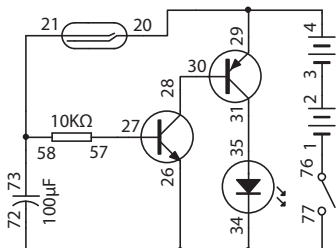

Experiment 27

Touch control delayed extinguishing LED

Wiring Sequence 1-76, 2-3, 4-29-48, 73-58-47, 57-27, 30-28, 31-35, 26-34-72-77

- Complete all wiring connections as indicated in the sequence. Switch on the main switch. Touch the touch-plate with finger. You may have to dampen your finger with water before touching. The circuit is then connected and electricity will flow through the transistor so that LED will light up. At the same time the capacitor is being charged. Then remove your finger. Note that you may have to wipe the water off the touch-plate. You will see the transistor can still keep conductive for some time as the capacitor will release the stored electricity. Therefore the LED will not extinguish immediately after you remove your finger from the touch-plate.

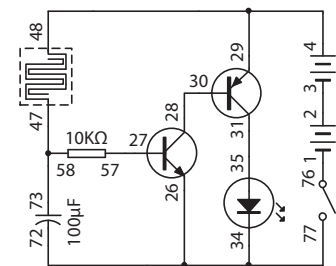

Experiment 28

Light control activated LED light

Wiring Sequence 1-76, 2-3, 4-29-62, 73-58-61, 57-27, 30-28, 31-35, 26-34-72-77

- Complete all wiring connections as indicated in the sequence. Switch on the main switch. LED will light up. Cover the Light Sensor completely, and wait for some time. The LED will become dimmer and dimmer gradually. Finally it will extinguish. If you take away the cover thing, the LED will light up immediately. You can repeat the experiment by covering the Light Sensor again for some time.

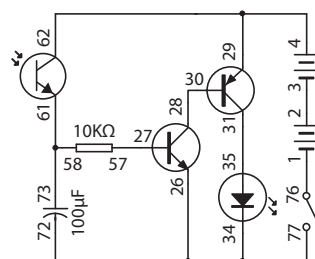

Experiment 29

Super LED light activated by darkness

Wiring Sequence 1-76, 2-3, 4-29-59, 61-34-26-77, 62-60-27, 28-30, 35-31

- Complete all wiring connections as indicated in the sequence. Switch on the main switch. When the Light Sensor is completely covered, the LED will light up. Uncover the Light Sensor and shine it with bright light. Then the LED will extinguish. This is because of the light falling on the Light Sensor changes its resistance.

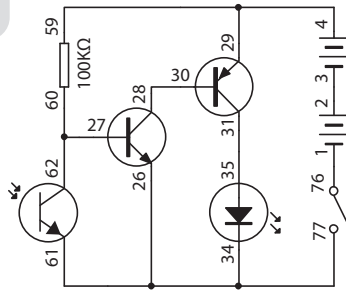

Experiment 30

Light control extinguish-and-light super LED light

Wiring Sequence 1-76, 2-3, 4-29-60-62, 73-58-61, 72-59-27, 30-28, 31-35, 26-34-57-77

- Complete all wiring connections as indicated in the sequence. Switch on the main switch. LED will light up. Cover the Light Sensor completely, then LED will extinguish. Keep on covering the Light Sensor for a while. After some time, the LED will light up again! If you want to repeat the experiment, just cover the Light Sensor again.

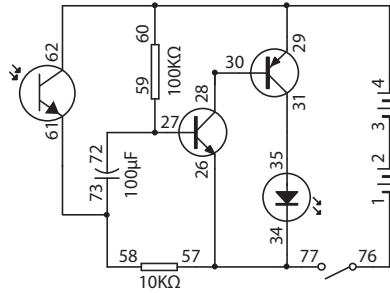

Experiment 31

Adjustable and blow-able super LED light

Wiring Sequence 1-76, 2-3, 4-33-51-54-15, 32-35, 64-49-25, 52-65, 28-50-53, 27-58-14, 26-34-57-63-77

- Complete all wiring connections as indicated in the sequence. Switch on the main switch. Turn the variable resistor from minimum to maximum, and the super LED light will change from dim to bright. Adjust the variable resistor to a position which just causes the light to be extinguished. And then if you clap your hands near the microphone, blow to the microphone, or speak loudly near the microphone will cause the super LED to light up.

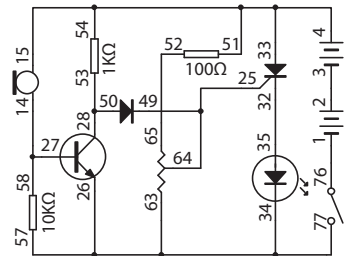

Experiment 32

Manual control extinguish-and-light super LED light

Wiring Sequence 1-76, 2-3, 4-29-60-45, 73-58-46, 72-59-27, 30-28, 31-35, 26-34-57-77

- Complete all wiring connections as indicated in the sequence. Switch on the main switch. LED will light up. Press the push switch once and release immediately, then LED will extinguish. Just wait for a while. After some time, the LED will light up again! If you want to repeat the experiment, just press the push switch again.

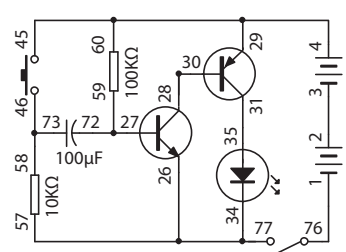

Experiment 33

Water droplet activated simulated motor sound with LED

Wiring Sequence 74-59-26-77, 76-1, 2-3, 4-51, 52-75-8-39, 38-29, 30-47, 30-47, 48-70-60-19, 18-71-53, 54-7-28, 27-31

- Complete all wiring connections as indicated in the sequence. Switch on the main switch. Then drip a drop of water onto the touch plate. The circuit will be connected and thus the speaker will produce motor sound. At the same time, the LED will light up. When you wipe the water off the touch plate, the circuit is disconnected and thus everything will stop.

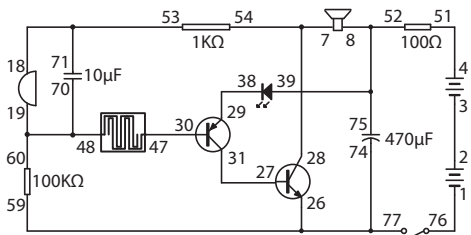

Experiment 34

Water droplet activated simulated ship sound with LED

Wiring Sequence 74-59-26-77, 76-1, 2-3, 4-51, 52-75-8-39, 38-29, 30-47, 48-68-60-19, 18-69-53, 54-7-28, 27-31

- Complete all wiring connections as indicated in the sequence. Switch on the main switch. Then drip a drop of water onto the touch plate. The circuit will be connected and thus the speaker will produce ship sound. At the same time, LED will light up. When you wipe the water off the touch plate, the circuit is disconnected and thus everything will stop.

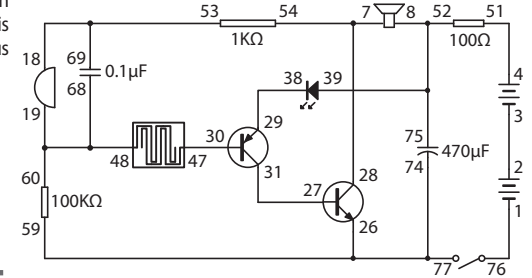

Experiment 35

Water droplet activated simulated delayed motor sound with LED

Wiring Sequence 74-59-26-77, 76-1, 2-3, 4-51, 52-75-8-39, 38-29, 30-47, 48-72-60-19, 18-73-53, 54-7-28, 27-31

- Complete all wiring connections as indicated in the sequence. Switch on the main switch. Then drip a drop of water onto the touch plate. The circuit will be connected and after a few seconds the speaker will produce motor sound. At the same time, the LED will light up. When you wipe the water off the touch plate, the circuit is disconnected and thus everything will stop.

NOTE: If the experiment does not work, you may need to "discharge" the capacitor first. To "discharge", connect any wire to 72-73 for a second. This way the electricity stored in the capacitor will be "discharged" and then the experiment can work again.

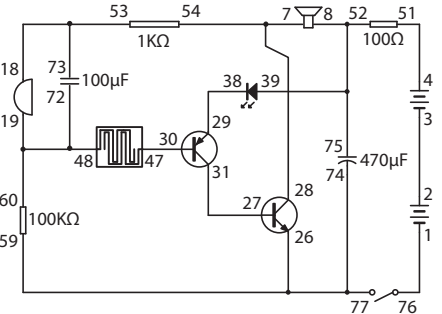

Experiment 36

Magnet control motor dory sound with red LED

Wiring Sequence 1-76, 2-3, 4-51, 52-8-39-75, 7-28-54, 18-53-66, 19-30-67-60, 31-20-73, 27-21-72, 38-29, 74-59-26-77

- Complete all wiring connections as indicated in the sequence. Switch on the main switch. Then use the magnetic pole to access the reed switch. The circuit will be connected and thus the speaker will produce motor dory sound. At the same time red LED will light up. When the magnetic pole is removed from the reed switch, the circuit is disconnected and thus everything will stop.

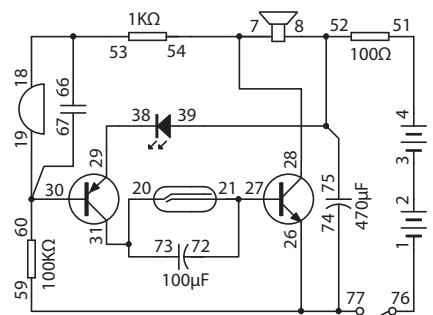

Experiment 37

Magnet control motor dory sound with green LED

Wiring Sequence 1-76, 2-3, 4-51, 52-8-37-75, 7-28-54, 18-53-66, 19-30-67-60, 31-20-73, 27-21-72, 36-29, 74-59-26-77

- Complete all wiring connections as indicated in the sequence. Switch on the main switch. Then use the magnetic pole to access the reed switch. The circuit will be connected and thus the speaker will produce motor dory sound. At the same time green LED will light up. When the magnetic pole is removed from the reed switch, the circuit is disconnected and thus everything will stop.

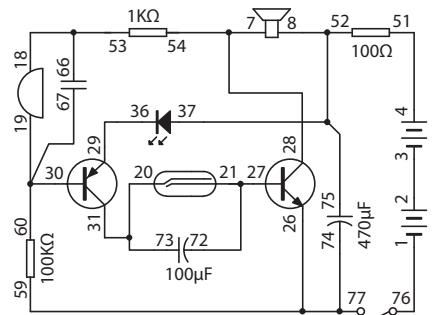

Experiment 38

Magnet control ship sound with LED

Wiring Sequence 1-76, 2-3, 4-51, 52-8-37-75, 7-28-54, 18-53-68, 19-30-69-60, 31-20-73, 27-21-72, 36-29, 74-59-26-77

- Complete all wiring connections as indicated in the sequence. Switch on the main switch. Then use the magnetic pole to access the reed switch. The circuit will be connected and thus the speaker will produce ship sound. At the same time LED will light up. When the magnetic pole is removed from the reed switch, the circuit is disconnected and thus everything will stop.

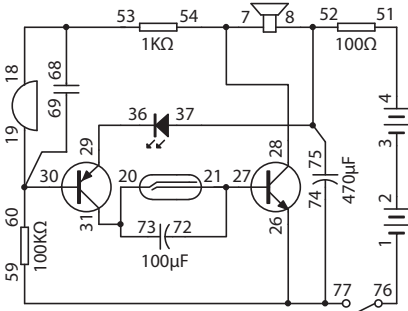

Experiment 39

Magnet control electronic metronome with LED

Wiring Sequence 1-76, 2-3, 4-51, 52-8-37-75, 7-28-54, 53-71, 30-70-60, 31-20-73, 27-21-72, 36-29, 74-59-26-77

- Complete all wiring connections as indicated in the sequence. Switch on the main switch. Then use the magnetic pole to access the reed switch. The circuit is then connected and the speaker will make a sound and LED will light up. Remove the magnetic pole, then LED will flash and gradually extinguish. At the same time speaker will produce "dic, dic" sound and gradually stop. Both LED and speaker are like oscillating and will fade out gradually.

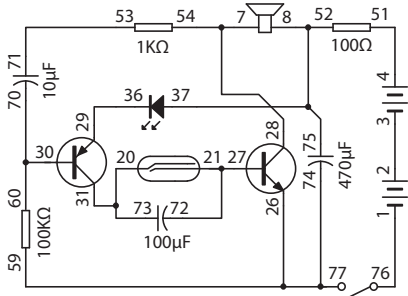

Experiment 40

Manual control electronic metronome with LED

Wiring Sequence 1-76, 2-3, 4-51, 52-8-37-75, 7-28-54, 53-71, 30-70-60, 31-46-73, 27-45-72, 36-29, 74-59-26-77

- Complete all wiring connections as indicated in the sequence. Switch on the main switch. Then press the push switch. The circuit is then connected and the speaker will make a sound and LED will light up. Release the push switch, then LED will flash and gradually extinguish. At the same time speaker will produce "dic, dic" sound and gradually stop. Both LED and speaker are like oscillating and will fade away gradually.

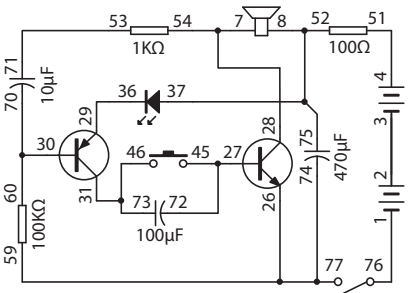

Experiment 41

Manual control motor dory sound with red LED

Wiring Sequence 1-76, 2-3, 4-51, 52-8-39-75, 7-28-54, 18-53-66, 19-30-67-60, 31-46-73, 27-45-72, 38-29, 74-59-26-77

- Complete all wiring connections as indicated in the sequence. Switch on the main switch. Press the push switch. The circuit will be connected and thus the speaker will produce motor dory sound. At the same time red LED will light up. And then release the push switch. The circuit is disconnected and thus everything will stop.

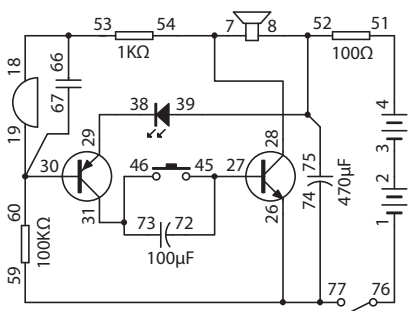

Experiment 42

Manual control motor dory sound with green LED

Wiring Sequence 1-76, 2-3, 4-51, 52-8-37-75, 7-28-54, 18-53-66, 19-30-67-60, 31-46-73, 27-45-72, 36-29, 74-59-26-77

- Complete all wiring connections as indicated in the sequence. Switch on the main switch. Press the push switch. The circuit will be connected and thus the speaker will produce motor dory sound. At the same time green LED will light up. And then release the push switch. The circuit is disconnected and thus everything will stop.

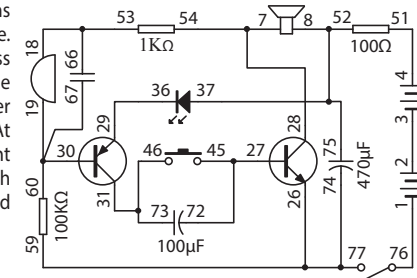

Experiment 43

Manual control ship sound with LED

Wiring Sequence 1-76, 2-3, 4-51, 52-8-37-75, 7-28-54, 18-53-68, 19-30-69-60, 31-46-73, 27-45-72, 36-29, 74-59-26-77

- Complete all wiring connections as indicated in the sequence. Switch on the main switch. Press the push switch. The circuit will be connected and thus the speaker will produce ship sound. At the same time LED will light up. And then release the push switch. The circuit is disconnected and thus everything will stop.

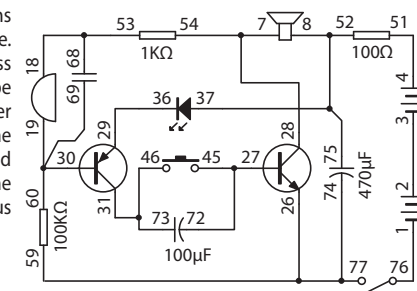

Experiment 44

Manual control delayed motor dory sound

Wiring Sequence 1-76, 2-3, 7-26-72-74-52, 51-77, 28-30, 8-31-19, 18-54, 27-53-60, 46-59-73, 4-29-45-75

- Complete all wiring connections as indicated in the sequence. Switch on the main switch. Press the push switch. The circuit will be connected and thus the speaker will produce motor dory sound. And then release the push switch. The circuit is disconnected. However the motor dory sound will still prolong for a period and will fade away gradually.

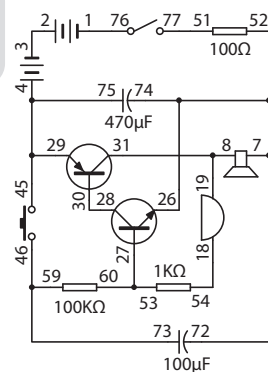

Experiment 45

Magnet control delayed motor dory sound

Wiring Sequence 1-76, 2-3, 7-26-72-74-52, 51-77, 28-30, 8-31-19, 18-54, 27-53-60, 20-59-73, 4-29-21-75

- Complete all wiring connections as indicated in the sequence. Switch on the main switch. Use the magnetic pole to access the reed switch. The circuit will be connected and thus the speaker will produce motor dory sound. And then remove the magnetic pole. The circuit is disconnected. However the motor dory sound will still prolong for a period and will fade away gradually.

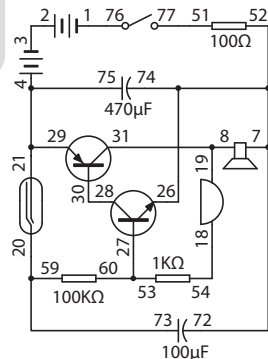

Experiment 46

Manual control metronome

Wiring Sequence 1-76, 2-3, 7-26-72-74-52, 51-77, 28-30, 8-31-70, 54-71, 27-53-60, 46-59-73, 4-29-45-75

- Complete all wiring connections as indicated in the sequence. Switch on the main switch. Then press the push switch. The circuit is then connected and the speaker will produce "dic, dic" sound. When the push switch is released, speaker will still keep on producing the "dic, dic" sound, but the sound will gradually fading away and stop finally.

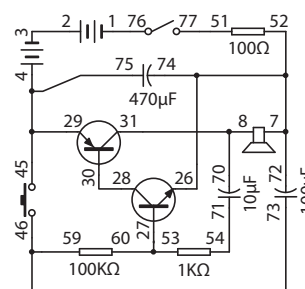

Experiment 47

Multitone producer

Wiring Sequence 1-76, 2-3, 74-36-77-7, 8-31-65, 26-37, 28-30, 4-51, 52-29-60-75, 66-59-27, 67-64

- Complete all wiring connections as indicated in the sequence. Switch on the main switch. Then the loudspeaker will make a noisy sound and LED will light up. Adjusting the variable resistor for changing the resistance will affect the sound and the brightness of the LED.

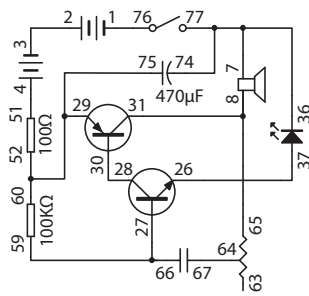

Experiment 48

Magnet control multitone producer

Wiring Sequence 1-76, 2-3, 74-36-77-7, 8-31-65, 26-37, 28-30, 4-51, 52-29-60-75, 66-27-21, 67-64, 59-20

- Complete all wiring connections as indicated in the sequence. Switch on the main switch. Use a magnetic pole to access the reed switch. Then the circuit will be connected and the loudspeaker will make a noisy sound and LED will light up. Adjusting the variable resistor for changing the resistance will affect the sound and the brightness of the LED.

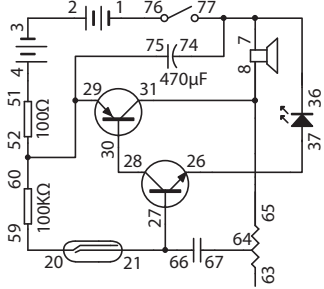

Experiment 49

Manual control multitone producer

Wiring Sequence 1-76, 2-3, 74-36-77-7, 8-31-65, 26-37, 28-30, 4-51, 52-29-60-75, 66-27-45, 67-64, 59-46

- Complete all wiring connections as indicated in the sequence. Switch on the main switch. Press the push switch, and then the circuit will be connected. The loudspeaker will make a noisy sound and LED will light up. Adjusting the variable resistor for changing the resistance will affect the sound and the brightness of the LED.

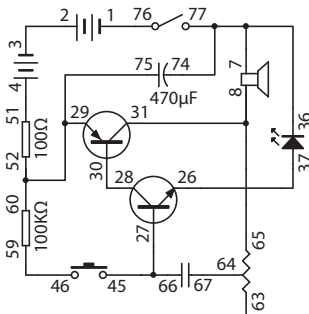

Experiment 50

Electronic cicada

Wiring Sequence 1-76, 2-3, 74-36-77-7, 8-31-65, 26-37, 28-30, 4-51, 52-29-60-75, 69-59-27-18, 19-64-68

- Complete all wiring connections as indicated in the sequence. Switch on the main switch. The LED will light up and loudspeaker will produce cicada like sound. Adjusting the variable resistor for changing the resistance will affect the sound tone and the brightness of LED.

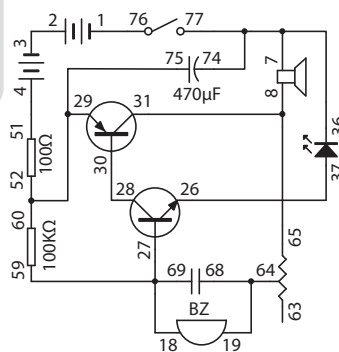

Experiment 51

Light control creaking sound

Wiring Sequence 1-76, 2-3, 74-36-77-7, 8-31-65, 26-37, 28-30, 4-51, 52-29-62-75, 69-61-27-18, 19-64-68

- Complete all wiring connections as indicated in the sequence. Switch on the main switch. LED will light up. Loudspeaker will produce creaking sound unless the variable resistor is in the minimum position. Then shade the Light Sensor a little bit. The brightness of the LED will decrease, and the tone of the creaking sound will change. The more you shade the Light Sensor, the more change on the tone of the sound and the dimmer the LED will be. You can also adjust the variable resistor to obtain different effect.

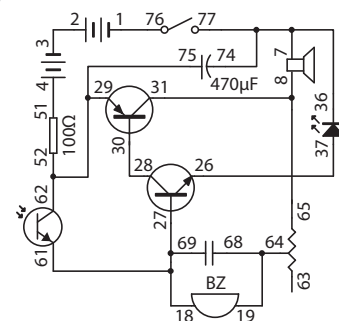

Experiment 52

Ship sound

Wiring Sequence 1-76, 2-3, 74-36-77-7, 8-31-65, 26-37, 28-30, 4-51, 52-29-60-75, 69-67-59-27, 66-64-68

- Complete all wiring connections as indicated in the sequence. Switch on the main switch. Then the loudspeaker will produce ship sound. Adjusting the variable resistor can change the resistance and hence change the sound tone.

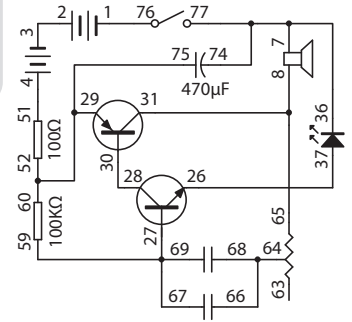

Experiment 53

Adjustable flashing LED light

Wiring Sequence 1-76, 2-3, 74-64-36-34-77, 65-70-35-31, 26-37, 28-30, 4-51, 52-29-60-75, 71-59-27

- Complete all wiring connections as indicated in the sequence. Switch on the main switch. The LED will light up. Adjusting the variable resistor will change the LED from flashing to not flashing. When the variable resistor is at its maximum position, the LED will flash. When the variable resistor is at its minimum position, the LED will not flash.

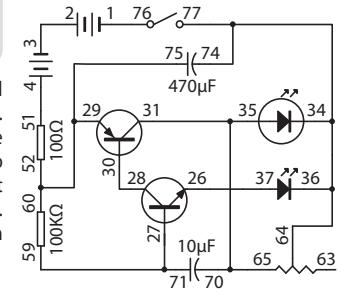

Experiment 54

Magnet control adjustable flashing LED light

Wiring Sequence 1-76, 2-3, 74-64-36-34-77, 70-65-35-31, 26-37, 28-30, 4-51, 52-21-29-75, 60-20, 71-59-27

- Complete all wiring connections as indicated in the sequence. Switch on the main switch. Use a magnetic pole to access the reed switch. The circuit is then connected. LED will light up. Adjusting the variable resistor will change the LED from flashing to not flashing. When the variable resistor is at its maximum position, the LED will flash. When the variable resistor is at its minimum position, the LED will not flash.

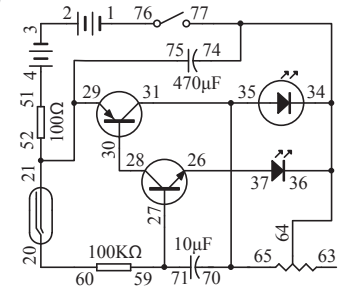

Experiment 55

Morse code training kit

Wiring Sequence 2-3, 4-53, 54-39, 38-46, 1-45

- Complete all wiring connections as indicated in the sequence. By tapping the push switch, LED will flash. This is equivalent to the principle of Morse-Code. By learning the Morse-Code table, it is possible to send a message out at night.

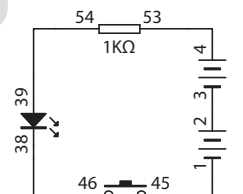

Experiment 56

Bore some humming

Wiring Sequence 1-7-36-74, 2-3, 26-37, 4-51, 75-60-29-52, 30-45, 28-46, 27-59-67, 8-31-66

- Complete all wiring connections as indicated in the sequence. When the push switch is pressed, LED will light up, and the loudspeaker will produce bore some humming sound like that of a mosquito.

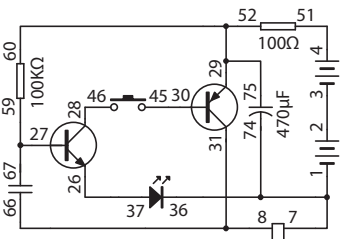

Experiment 57

Automobile's "di-di" sound

Wiring Sequence 1-7-36-74, 2-3, 26-37, 4-51, 75-60-29-52, 30-45, 28-46, 27-59-69, 8-31-68

- Complete all wiring connections as indicated in the sequence. When the push switch is pressed, LED will light up, and the loudspeaker will produce "di, di" sound like that of automobile.

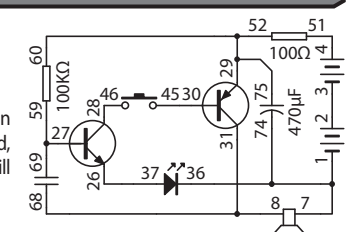

Experiment 58

Hoofbeat

Wiring Sequence **1-7-36-74, 2-3, 26-37, 4-51, 75-60-29-52, 30-45, 28-46, 27-59-71, 8-31-70**

- Complete all wiring connections as indicated in the sequence. When the push switch is pressed, LED will light up, and the loudspeaker will produce hoofbeat like sound.

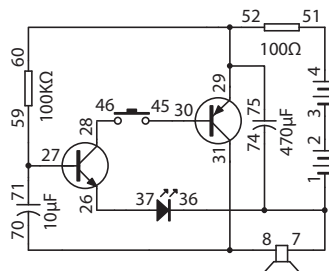

Experiment 59

AM radio receiver with mute function

Wiring Sequence **1-7-6, 2-3, 4-40-54-55-58, 7-44, 43-38-77-8, 9-16-59-66, 22-17-10, 71-68-60-57-24, 42-28-70, 69-67-41-26-23, 39-53, 27-46, 45-56**

- Complete all wiring connections as indicated in the sequence. Switch on the main switch. Then the LED will light up. Adjusting the variable condenser to suitable position will allow it to receive AM radio signals. By pressing the push switch, the radio will be mute. Since AM radio wave is sensitive towards signal direction, when the radio signal is weak, try to move the radio to other direction.

Note: If you cannot receive AM signal in indoor area, you can go to outdoor areas and try again.

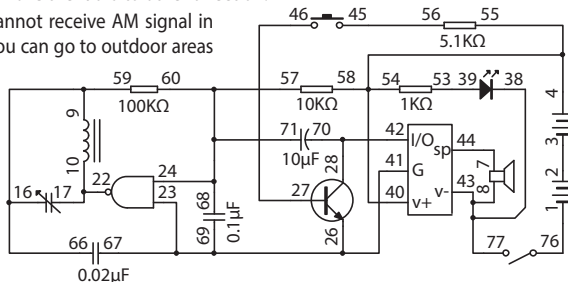

Experiment 60

Big voice AM radio receiver with volume control

Wiring Sequence **1-7-6, 2-3, 4-40-54-58, 7-44, 43-38-77-8, 9-16-59-66, 22-17-10, 71-56, 68-60-57-55-24, 65-70, 69-67-63-41-23, 64-42, 53-39**

- Complete all wiring connections as indicated in the sequence. Switch on the main switch. Then the LED will light up. Adjusting the variable condenser to suitable position will allow it to receive AM radio signals. Adjusting the variable resistor can change the volume. Since AM radio wave is sensitive towards signal direction, when the radio signal is weak, try to move the radio to other direction.

Note: If you cannot receive AM signal in indoor area, you can go to outdoor areas and try it again.

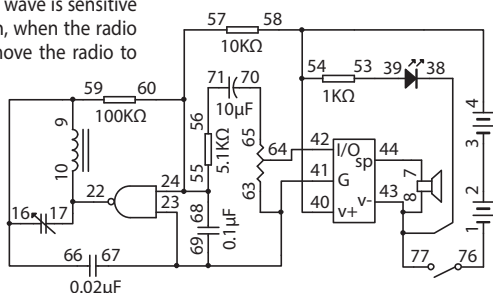

Experiment 61

Magnet control AM radio receiver with volume control

Wiring Sequence **1-21, 2-3, 4-40-54-58, 7-44, 43-38-20-8, 9-16-59-66, 22-17-10, 71-56, 68-60-57-55-24, 65-70, 23-41-63-67-69, 64-42, 53-39**

- Complete all wiring connections as indicated in the sequence. Switch on the main switch. Use the magnetic pole to access the reed switch. The circuit is connected and LED will light up. Adjusting the variable condenser to suitable position will allow it to receive AM radio signals. Adjusting the variable resistor can change the volume. Since AM radio wave is sensitive towards signal direction, when the radio signal is weak, try to move the radio to other direction.

Note: If you cannot receive AM signal in indoor area, you can go to outdoor areas and try it again.

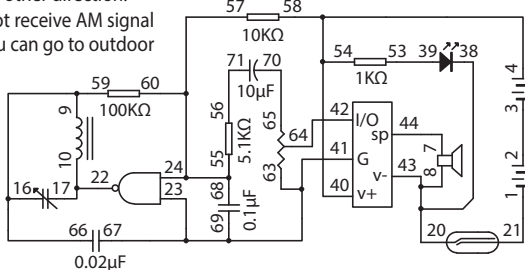

Experiment 62

Daylight activated AM radio receiver with volume control

Wiring Sequence **1-7-6, 2-3, 4-40-54-62, 7-44, 43-38-77-8, 9-16-59-66, 22-17-10, 71-56, 68-61-60-55-24, 65-70, 23-41-69-67-63, 64-42, 53-39**

- Complete all wiring connections as indicated in the sequence. Switch on the main switch. Then the LED will light up. However if the Light Sensor is shaded, then the radio cannot work. It is necessary for the Light Sensor to be shone by bright light so that this circuit is connected. Adjusting the variable condenser to suitable position will allow it to receive AM radio signals. Since AM radio wave is sensitive towards signal direction, when the radio signal is weak, try to move the radio to other direction.

Note: If you cannot receive AM signal in indoor area, you can go to outdoor areas and try it again.

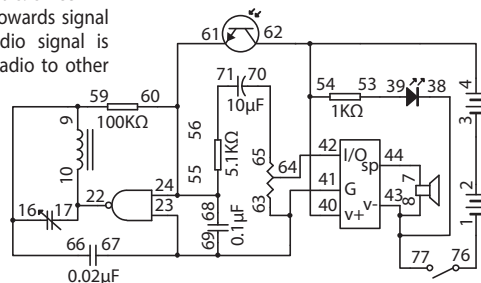

Experiment 63

Darkness activated AM radio receiver with volume control

Wiring Sequence **1-7-6, 2-3, 4-40-54-58, 7-44, 43-38-77-8, 9-16-59-62-66, 22-17-10, 71-56, 68-60-57-55-24, 65-70, 69-67-63-61-41-23, 64-42, 53-39**

- Complete all wiring connections as indicated in the sequence. Switch on the main switch. Then the LED will light up. If there are bright light shines on the Light Sensor, then the radio cannot work. It is necessary for the Light Sensor to be shaded so that this circuit is connected. Adjusting the variable condenser to suitable position will allow it to receive AM radio signals. Since AM radio wave is sensitive towards signal direction, when the radio signal is weak, try to move the radio to other direction.

Note: If you cannot receive AM signal in indoor area, you can go to outdoor areas and try it again.

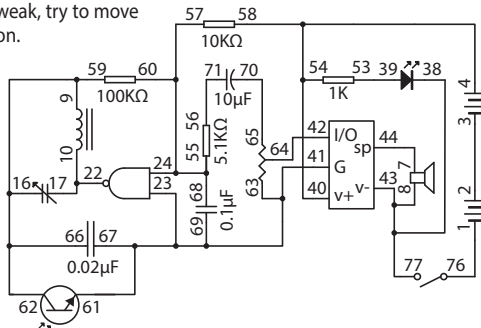

Experiment 64

Big voice FM radio receiver

Wiring Sequence **1-7-6, 2-3, 4-40-11, 12-41, 13-42, 44-7, 8-43-77**

- Complete all wiring connections as indicated in the sequence. Switch on the main switch. If you press the button "select", which is located at the left side of the panel, then it will perform a FM auto-search. The receiver will search for channel from lower end to upper end. It will stop searching when it finds a channel. You may press search again to let it search for another channel. You will have to press the "reset" button if the receiver has searched to the upper most channel and cannot find anything. It is recommended to add a wire on the "FM. ANT", which is located on the left side of the panel. The wire will act as an antenna. This will increase the strength of the radio signal received.

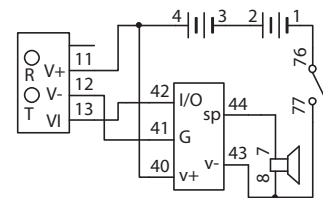

Experiment 65

Big voice FM radio receiver with volume control

Wiring Sequence **1-7-6, 2-3, 4-40-11, 12-41-63, 13-65, 44-7, 8-43-77, 42-64**

- Complete all wiring connections as indicated in the sequence. Switch on the main switch. If you press the button "select", which is located at the left side of the panel, then it will perform a FM auto-search. The receiver will search for channel from lower end to upper end. It will stop searching when it finds a channel. You may press search again to let it search for another channel. You will have to press the "reset" button if the receiver has searched to the upper most channel and cannot find anything. Adjusting the variable resistor can change the volume. It is recommended to add a wire on the "FM. ANT", which is located on the left side of the panel. The wire will act as an antenna. This will increase the strength of the radio signal received.

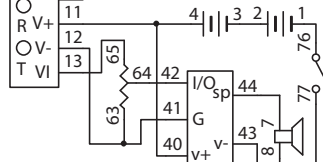

Experiment 66

Daylight activated FM radio receiver with volume control

Wiring Sequence 1-76, 2-3, 42-64, 62-59-30, 11-31, 40-60-29-4, 12-41-61-63, 13-65, 44-7, 8-43-77

- Complete all wiring connections as indicated in the sequence. Switch on the main switch. The circuit is connected. However if the Light Sensor is shaded, then the circuit will be disconnected and the radio cannot work. Therefore it is necessary for the Light Sensor to be shone by bright light so that this circuit is connected. If you press the button "select", which is located at the left side of the panel, then it will perform a FM auto-search. The receiver will search for channel from lower end to upper end. It will stop searching when it finds a channel. You may press search again to let it search for another channel. You will have to press the "reset" button if the receiver has searched to the upper most channel and cannot find anything. Adjusting the variable resistor can change the volume. It is recommended to add a wire on the "FM. ANT", which is located on the left side of the panel. The wire will act as an antenna. This will increase the strength of the radio signal received.

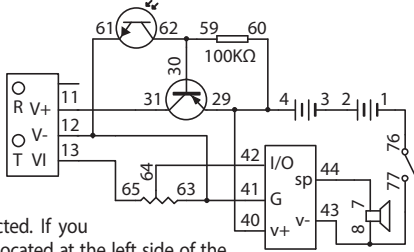

Experiment 67

Darkness activated FM radio receiver with volume control

Wiring Sequence 1-76, 2-3, 30-61-60, 11-31, 40-62-29-4, 12-41-63-59, 13-65, 44-7, 8-43-77, 42-64

- Complete all wiring connections as indicated in the sequence. Switch on the main switch. If the Light Sensor is not shaded, then the radio cannot work. Therefore it is necessary for the Light Sensor to be shaded so that this circuit is connected. If you press the button "select", which is located at the left side of the panel, then it will perform a FM auto-search. The receiver will search for channel from lower end to upper end. It will stop searching when it finds a channel. You may press search again to let it search for another channel. You will have to press the "reset" button if the receiver has searched to the upper most channel and cannot find anything. Adjusting the variable resistor can change the volume. It is recommended to add a wire on the "FM. ANT", which is located on the left side of the panel. The wire will act as an antenna. This will increase the strength of the radio signal received.

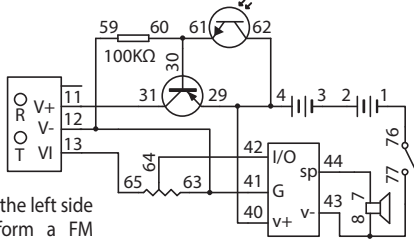

Experiment 68

Big voice AM/FM radio receiver with volume control

Wiring Sequence 1-76, 2-3, 4-40-58-11, 7-44 8-43-77, 9-16-59-66, 22-17-10, 71-56, 68-60-57-55-24, 12-23-63-69-67-41, 64-42

- Complete all wiring connections as indicated in the sequence. Switch on the main switch. If you want to use AM mode, connect spring terminal 65 to spring terminal 70. And then adjust the variable condenser to suitable position for receiving AM channels. Since AM radio wave is sensitive towards signal direction, when the radio signal is weak, try to move the radio to other directions. If you want to use FM mode, connect spring terminal 65 to spring terminal 13. Press the button "select", which is located at the left side of the panel. Then it will perform a FM auto-search. The receiver will search for channel from lower end to upper end. It will stop searching when it finds a channel. You may press search again to let it search for another channel. You will have to press the "reset" button if the receiver has searched to the upper most channel and cannot find anything. It is recommended to add a wire on the "FM. ANT", which is located on the left side of the panel. The wire will act as an antenna. This will increase the strength of the radio signal received. For both AM and FM mode, adjusting the variable resistor can change the volume. This circuit enables users to switch between AM and FM easily. Note: If you cannot receive AM signal in indoor area, you can go to outdoor areas and try it again.

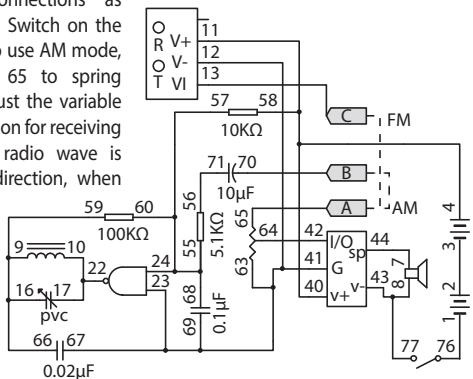

Experiment 69

Simple impact amplifier

Wiring Sequence 1-76, 2-3, 4-40-54-56, 7-44, 42-64, 63-41-36-18, 71-55-19, 8-43-77, 37-53, 65-70

- Complete all wiring connections as indicated in the sequence. Switch on the main switch. LED will light up. Slightly scratch the buzzer. You will find that the loudspeaker is amplifying the scratching sound. You may also beat the buzzer to hear the amplified sound of impact on the buzzer. Adjusting the variable resistor can change the volume. This principle can be used for security systems. People can fix a buzzer on the door, on the car door or on the window. Then if the door or window has been forced, loudspeaker will produce amplified impacting sound.

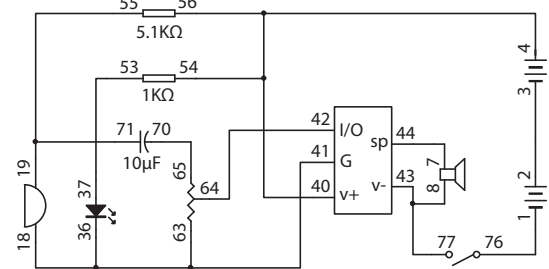

Experiment 70

Magnet control FM radio receiver with volume control

Wiring Sequence 1-8-43-60, 2-3, 4-29-58, 7-44, 57-20, 42-64, 63-41-12, 21-27-59, 28-30, 65-13, 11-26-31-40

- Complete all wiring connections as indicated in the sequence. Use the magnetic pole to access the reed switch. If you press the button "select", which is located at the left side of the panel, then it will perform a FM auto-search. The receiver will search for channel from lower end to upper end. It will stop searching when it finds a channel. You may press search again to let it search for another channel. You will have to press the "reset" button if the receiver has searched to the upper most channel and cannot find anything. Adjusting the variable resistor can change the volume. It is recommended to add a wire on the "FM. ANT", which is located on the left side of the panel. The wire will act as an antenna. This will increase the strength of the radio signal received.

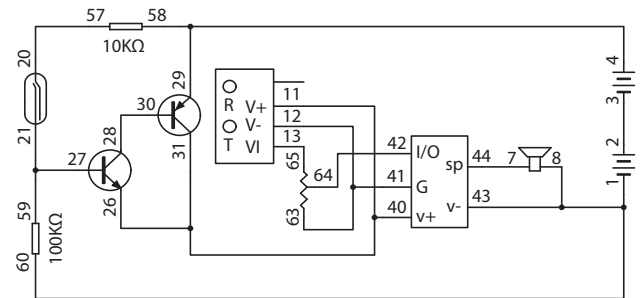

Experiment 71

Touch control FM radio receiver with volume control

Wiring Sequence 1-8-43-60, 2-3, 4-29-48, 7-44, 42-64, 63-41-12, 27-47-59, 28-30, 65-13, 11-26-31-40

- Complete all wiring connections as indicated in the sequence. Touch the touch plate with your finger. Note that if there is no response, you may need to dampen your finger first before touching. Then the circuit will be connected. If you press the button "select", which is located at the left side of the panel, then it will perform a FM auto-search. The receiver will search for channel from lower end to upper end. It will stop searching when it finds a channel. You may press search again to let it search for another channel. You will have to press the "reset" button if the receiver has searched to the upper most channel and cannot find anything. Adjusting the variable resistor can change the volume. It is recommended to add a wire on the "FM. ANT", which is located on the left side of the panel. The wire will act as an antenna. This will increase the strength of the radio signal received.

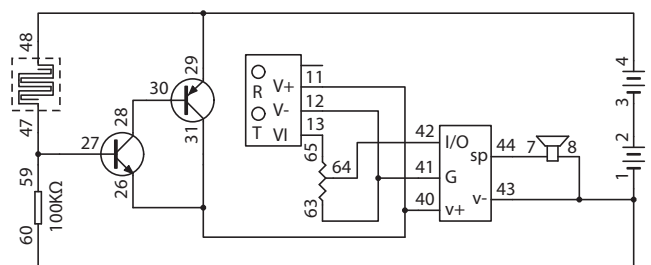

Experiment 72

FM radio receiver with mute function

Wiring Sequence 1-76, 2-3, 4-11-40-56, 12-26-41, 13-28-42, 44-7, 8-43-77, 55-46, 45-27

- Complete all wiring connections as indicated in the sequence. Switch on the main switch. If you press the button "select", which is located at the left side of the panel, then it will perform a FM auto-search. The receiver will search for channel from lower end to upper end. It will stop searching when it finds a channel. You may press search again to let it search for another channel. You will have to press the "reset" button if the receiver has searched to the upper most channel and cannot find anything. By pressing the push switch, the radio will be mute. It is recommended to add a wire on the "FM. ANT", which is located on the left side of the panel. The wire will act as an antenna. This will increase the strength of the radio signal received.

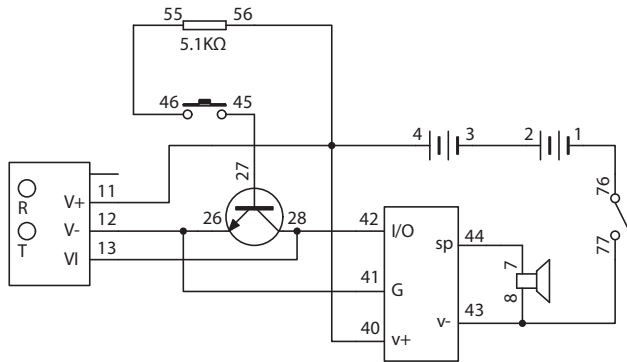

Experiment 73

Magnet control auto-sensor

Wiring Sequence 1-76, 2-3, 4-39-40, 71-21, 20-42, 70-44-7, 54-43-77-8, 38-53

- Complete all wiring connections as indicated in the sequence. Switch on the main switch. Use the magnetic pole to access the reed switch. The circuit is then connected and transferring the signal of loudspeaker to the input terminal, loudspeaker is producing self-coupled self-excited oscillating sound.

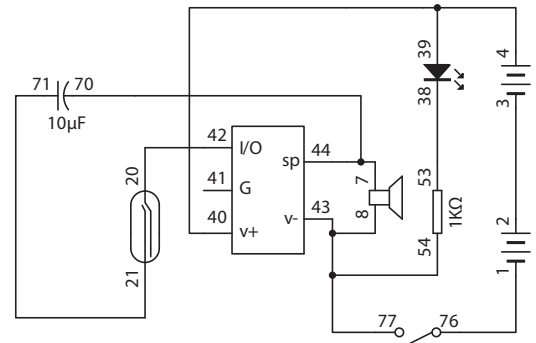

GLOSSARY

Amplifier - An electronic circuit that amplifies the signal that is sent to it. The amplifying component can be a transistor, vacuum tube or appropriate magnetic device.

Battery - A source of energy. It contains chemicals which will undergo chemical reaction to produce electricity when a circuit is connected.

Capacitance - A measurement of the capacity of a capacitor for storing electric charge.

Capacitor - A device consists of two conductors that are separated by an insulator. It is designed for storing electrical charge or as a filter in the circuit.

Circuit - A system of interconnected components / devices such as power source, resistors, capacitors and transistors...etc.

Diode - A device which is used in electric circuitry to allow an electric current to flow in single direction and block it in the reverse direction.

IC (Integrated Circuit) - A small electronic device made of a semiconductor material and is used for a variety of devices, including microprocessors, electronic equipment and automobiles.

Light Sensor - There are different types of light sensor. The one used here is a phototransistor. When light falls on it, it is like a switch connected and so current is allowed to pass through it.

LED (Light Emitting Diode) - A diode emits light when current is passing through it.

Microphone - A device converts sound into an electrical or acoustic signal

Motor - A device converts electrical energy to mechanical motion.

Reed Switch - A magnetically controlled switch made to open and close a circuit.

Resistance - A measurement of the degree to which an object opposes an electrical current through it.

Resistor - A device designed for possessing resistance.

Speaker - A device that changes electrical signals to sound.

Switch - A device for opening and closing power source to a circuit

Transistor - A semi-conductor material device that amplifies a signal and opens or closes a circuit.

Variable Resistor - A kind of resistor and a device of adjustable resistance in the electronic / electrical circuit.

Wire - A conductor that conducts electricity. Connecting a wire is like providing a path that allows electricity to flow through.



© Explore Scientific, LLC.
1010 S 48th Street, Springdale, AR 72762
explorescientificusa.com | 866.252.3811
All rights reserved. Made in China.



If at any time in the future you should need to dispose of this product please note that waste electrical products should not be disposed of with household waste. Please recycle where facilities exist. Check with your local authority or retailer for recycling advice. (Waste Electrical and Electronic Equipment Directive)