



8+
88-90135



14 **ELECTRONIC SCIENCE SET**

INSTRUCTIONS



14

ELECTRONIC SCIENCE SET

Welcome to the amazing world of one of Explore Science! Explore Science is a D.I.Y (do-it-yourself) educational science kit that provides useful knowledge about simple physics, and is suitable for children of 8 years old and up. "You'll be amazed" to find what you can learn as the activity enables you to learn realistic concept of basic physical theory.

Once you get started you will be able to build your understanding through experimenting and maybe trying out some interesting experiments on your own. The 14 Electronic Science Set is smartly designed for children to connect with ease and breeze. Simply snap all key components and modules together to start, and pull apart once finished.

WARNING: Only for use by children aged 8 years and older.

GLOSSARY

Assembly: A group of machine parts or components that fit together to form a complete unit.

Battery: A consumable for providing electricity. It contains chemicals which will undergo chemical reaction that produces electricity

Motor: A device converts electricity to rotatory mechanical motion.

Power: The energy force or strength generated by a physical system or machine.

Wire: A component which is used in the electronic / electrical industry as a conductor that is used to carry electricity or signals.

WARNING

Adult supervision and assistance is required.

This unit is only for use by children aged 8 years and older.

Not suitable for children under age 3 years old due to small part(s) and component(s) – **CHOKING**

HAZARD.

Read and follow all instructions in the manual before use.

This toy contains small parts and functional sharp points on components. Keep away from children under age 3 years.

4 x AA size batteries are required (not included).

Please retain the information and this manual for future reference.

Instructions for parents are included and have to be observed.

Do not aim at eyes and face. Do not use improvised projectiles.

Warning. Do not use close to the ear! Misuse may cause damage to hearing.

CAUTION!

Before setting up this unit, please double check and make sure all wiring connections you have made are correct before inserting the batteries and switching on the unit as failure may result in damage to components or the unit.

When experiment is finished, make sure the batteries are disconnected and switch off the unit before you clear away the wires. Do not apply any components or parts to the unit other than those provided with this kit.

Do not lock the motor or other moving parts. Otherwise it may cause overheating.

The toy is not to be connected to more than recommended number of power supplies.

BATTERY INFORMATION

Use 4 x AA size batteries (not included).

Remove batteries when not in use.

Batteries must be inserted with the correct polarity.

Non-rechargeable batteries are not to be recharged.

Re-chargeable batteries are only to be charged under adult supervision.

Re-chargeable batteries are to be removed from the toy before being charged.

Different types of batteries or new and used batteries are not to be mixed.

Exhausted batteries are to be removed from the toy.

The supply terminals are not to be short-circuited.

Only batteries of the same or equivalent types are to be used.

Do not dispose of the batteries in fire.

Do not mix old and new batteries.

Do not mix alkaline, carbon zinc and re-chargeable batteries.

WARNING! Do not short-circuit the battery terminals and spring connectors as this may cause overheating. Do not lock the motor or other moving parts as this may cause overheating.

READ & SAVE ASSEMBLY & OPERATION INSTRUCTIONS

There are two basic individual units in this kit, namely **MAZE CHALLENGE** and **BUBBLE SCIENCE**.

By changing different circuit connections and combinations, it can establish play sets of diverse function.

To ensure the success of the **ASSEMBLY**, be sure to read these instructions and review the diagrams thoroughly before starting.

A practice of basic circuit connection

Below is a demonstration of connecting a simple circuit. You can start with this simple circuit as a practice before moving to other advanced circuits.

First of all, take out the components shown in below diagram from your amazing connection kit. They may be packed in different bags. Then install them like the pictures shown.

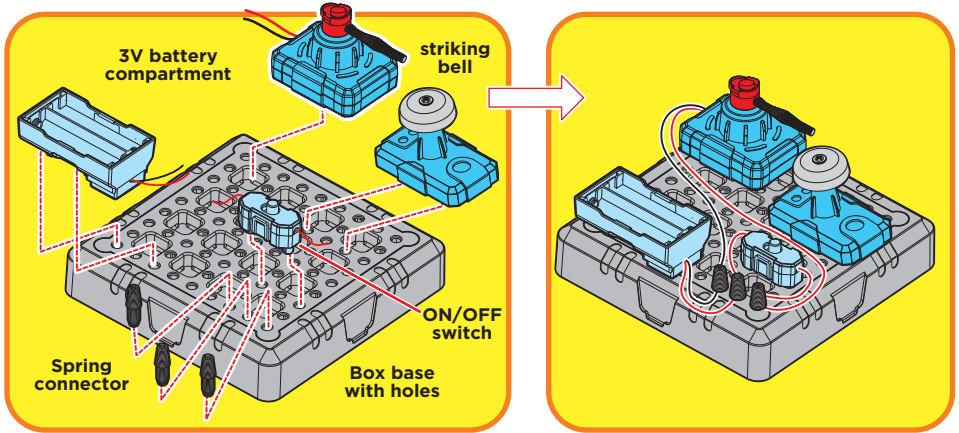
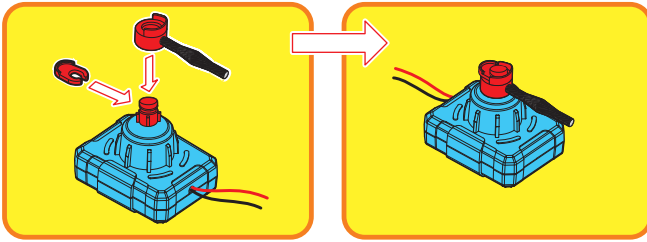

BASIC CONNECTION PRINCIPLE

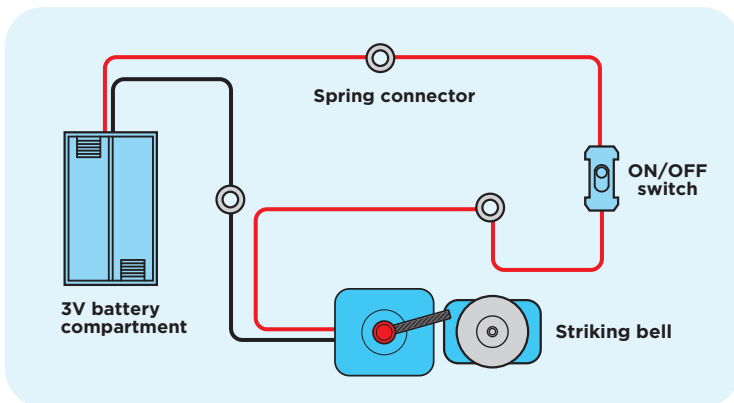

It is now done! Insert 2pcs AA size batteries to the 3V battery compartment. Turn the switch on. The circuit is connected and current can flow in the circuit. Then the bell will ring!

1 Maze Challenge

PARTS LIST

Description	Quantity
01. Bell module	1pc
02. Motor module	1pc
03. Box base with holes	1pc
04. 3V battery compartment	1pc
05. ON/OFF switch	1pc
06. Wand	1pc

Description	Quantity
07. Spring connector	6pcs (1spare)
08. Metal wire	1pc
09. Spring pole	1pc
10. C-shape plastic lock	1pc
11. Color filter	1pc
12. Flying disc	1pc
13. Eco-friendly reusable box	1pc

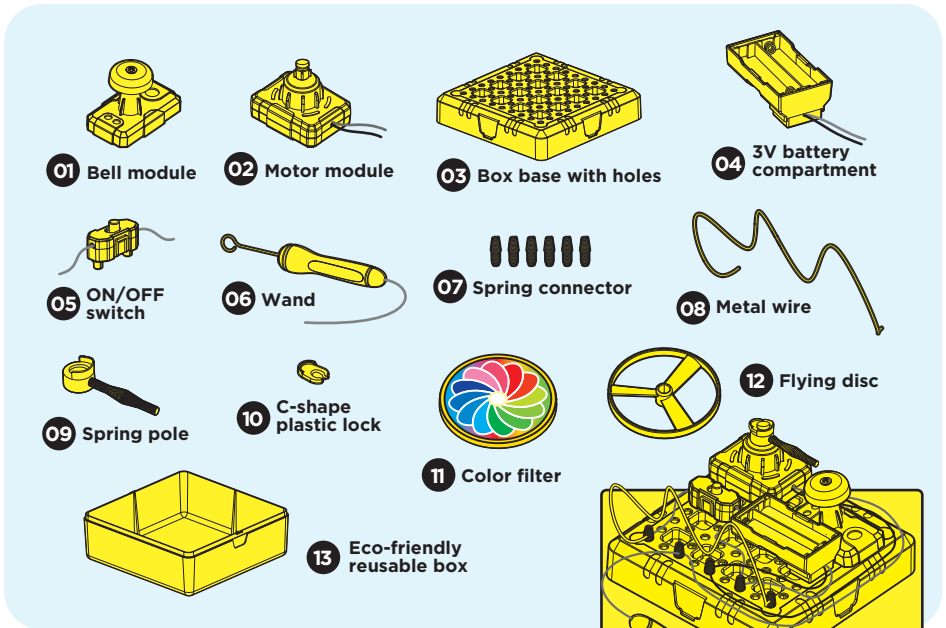

BASIC ASSEMBLY

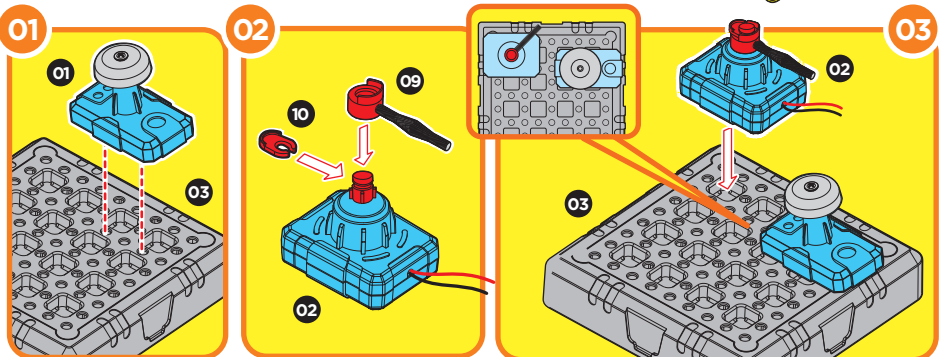

04

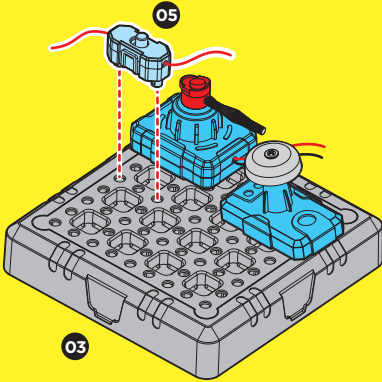

05

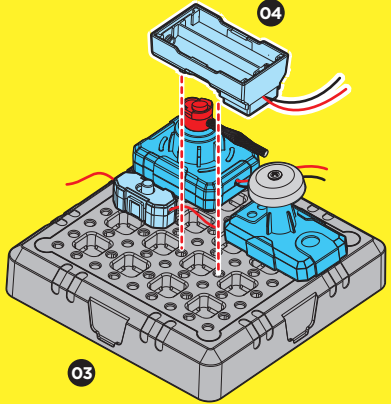

06

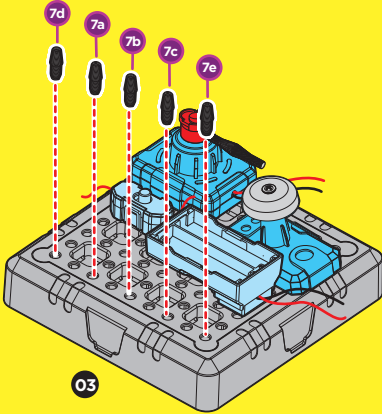

07

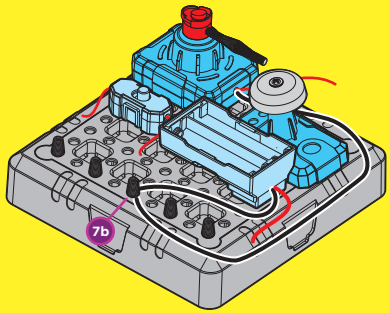

08

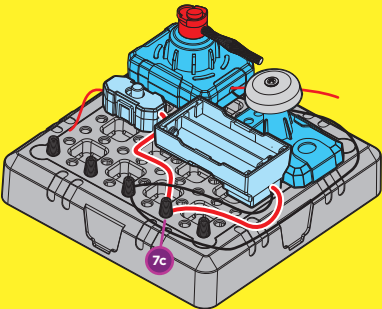

09

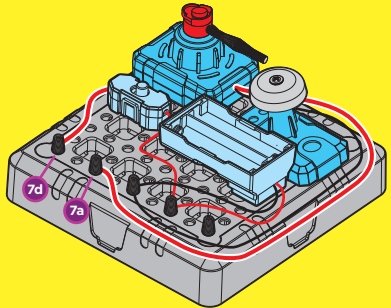

10

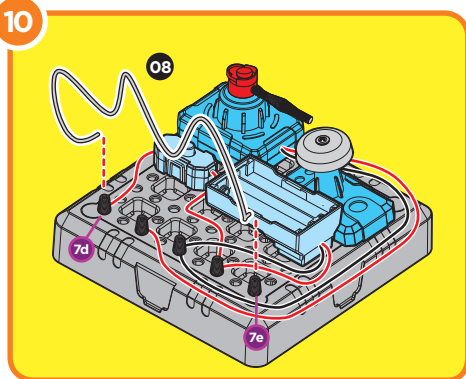

10• Fix the metal wire (08) on the spring connectors (7d) and (7e).

11

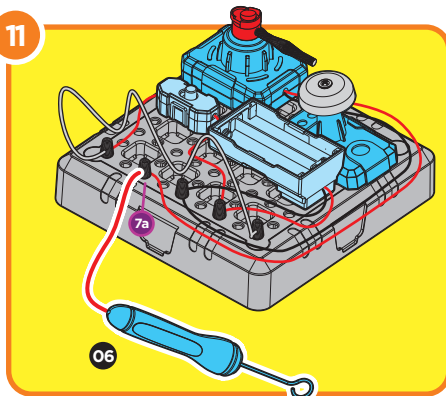

11• Connect the wand (06) to the spring connector (7a).

BASIC CONNECTION PRINCIPLE

Wiring connections	Spring (7a)	Spring (7b)	Spring (7c)	Spring (7d)	Spring (7e)
3V battery compartment (04)		black	red		
ON/OFF switch (05)			red	red	
Motor Module (02)	red	black			
Metal Wire (08)				silver	silver
Wand (06)	red				

How to play

It is now done! Insert 2pcs AA size batteries to the 3V battery compartment. Turn the switch on and put the ring of the wand around the metal wire via the open area of the ring. Keep your hand steady and carefully move the ring of the wand through the metal wire. If the ring touches the metal wire, the bell will ring and you lose!

Complete the maze to achieve the fastest time against your friends. Bend the metal wire to create different levels of difficulty. Please ensure the switch is off and batteries are removed from battery compartment before bending the metal wire.

You can switch to use other functions by replacing the spring pole with flying disc or color filter.

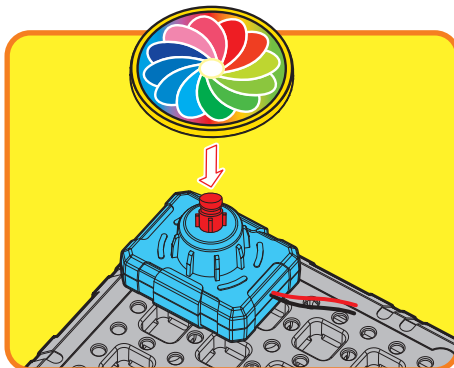
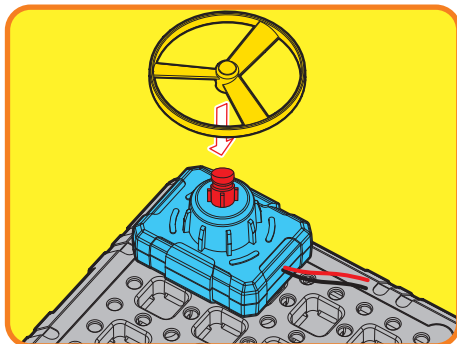
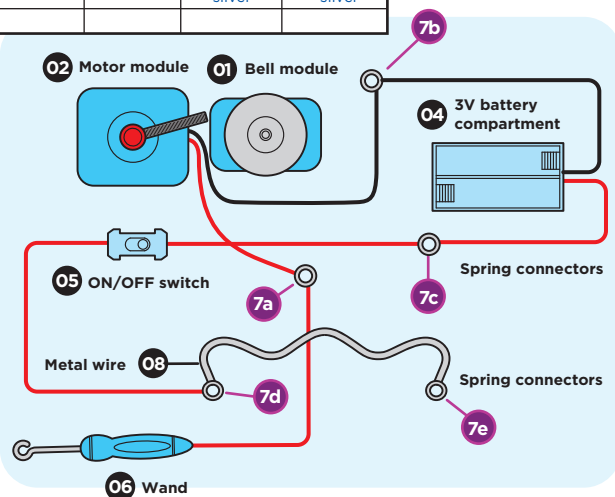

2 BUBBLE SCIENCE

PARTS LIST

Description	Quantity
01 3V Battery compartment	1pc
02 ON/OFF switch	1pc
03 Spring connector	3pcs
04 Box base with holes	1pc
05 Connecting bridge	2pcs

Description	Quantity
06 Blower module	1pc
07 Spinning unit	1pc
08 Blower cover	1pc
09 Bubble plate	1pc
10 Bubble solution container	1pc
11 Eco-friendly reusable box	1pc

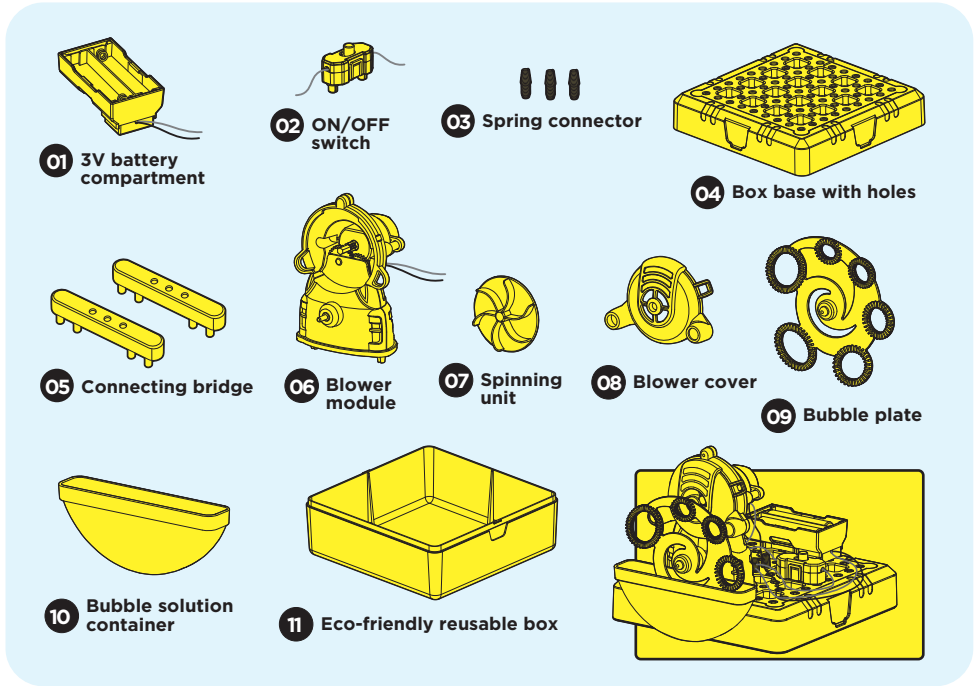

BASIC ASSEMBLY

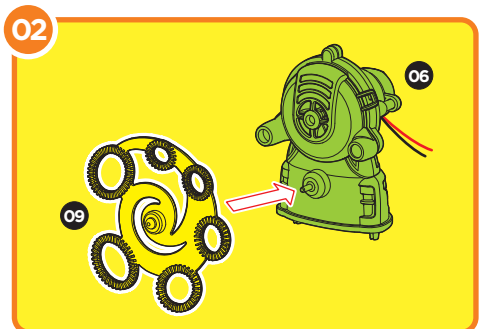
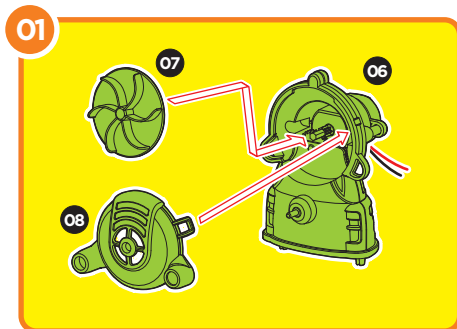

03

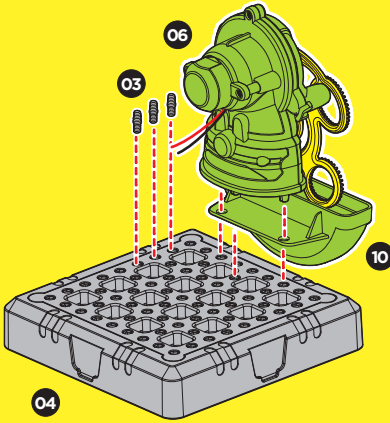

04

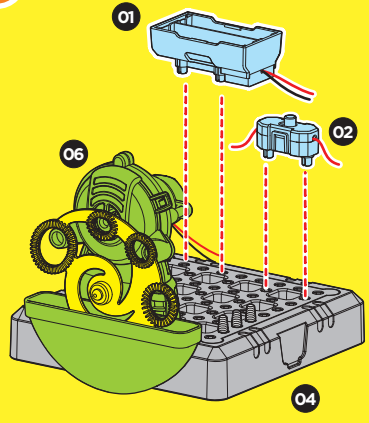

05

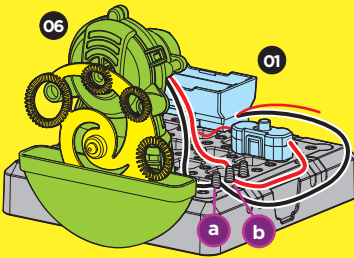

06

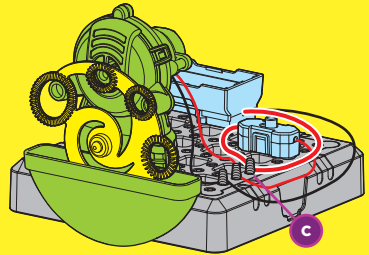

BASIC CONNECTION PRINCIPLE

Wiring connections	Spring (a)	Spring (b)	Spring (c)
3V battery compartment (01)	black		red
ON/OFF switch (02)		red	red
Blower Module (06)	black	red	

How to play

You need to firstly prepare some bubble solution. It may be bought from the shop, or made in the bathroom (under adult supervision) by adding soap into water to become the bubble solution. When bubble solution is available, fill it into the bubble solution container. Insert 2pcs AA size batteries to the 3V battery compartment. Turn ON the switch. The bubble plate will start to spin and the blower will blow out bubbles. You will see beautiful bubbles shooting out in continuous bubble stream!

Insert 2pcs AA size batteries to the 3V battery compartment. Turn ON the switch. The bubble plate will start to spin and the blower will blow out bubbles. You will see beautiful bubbles shooting out in continuous bubble stream!

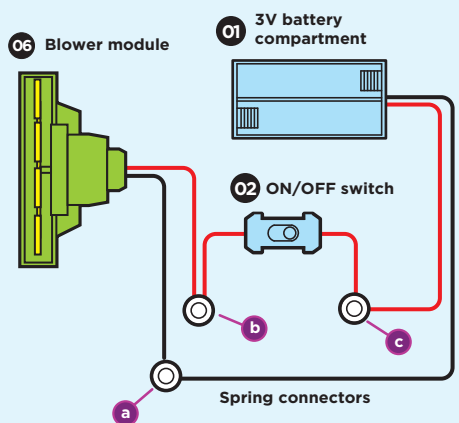

FOR MORE CONNECTING FUN!

After you have successfully assembled the basic individual units, you can create more exciting interaction with the **MAZE CHALLENGE** and **BUBBLE SCIENCE** together! Here are some basic things to note when using connecting bridges to connect these units together: If needed, you can adjust the position of the assembled parts on the box base with holes to suit the **2in1** connection. There's no need to keep their position exactly as the basic assembly. You can adjust their positions so long as the circuit connection is correct as the instruction.

There are 3 holes on each connecting bridge. Therefore switch or spring or other things can be installed onto the connecting bridges. This is useful when you find the box base with holes is crowded and hard to find rooms on it. These diagrams are examples:

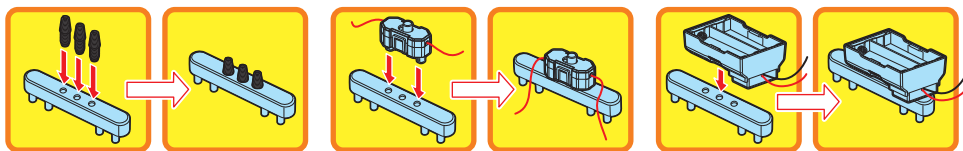

How to Connect

Put the 2 box bases together. Use connecting bridges to connect them firmly. Then follow below connecting diagrams to connect!

Connection symbols

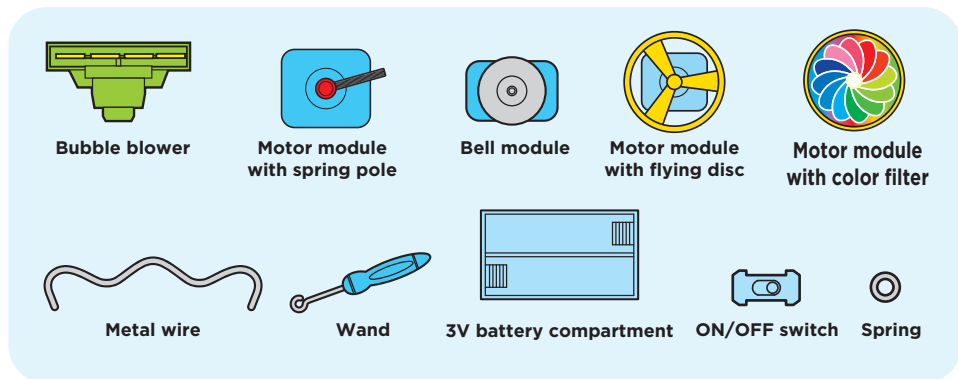

Connection diagrams

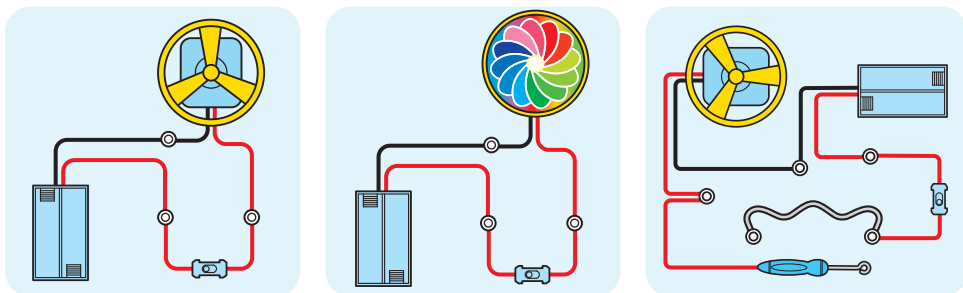

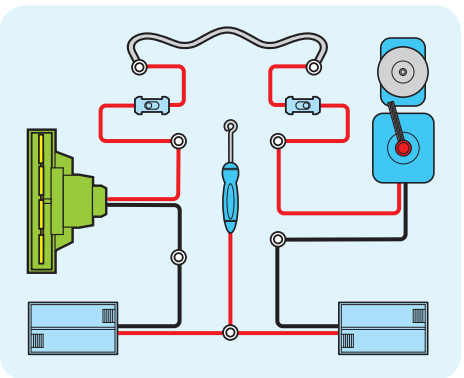
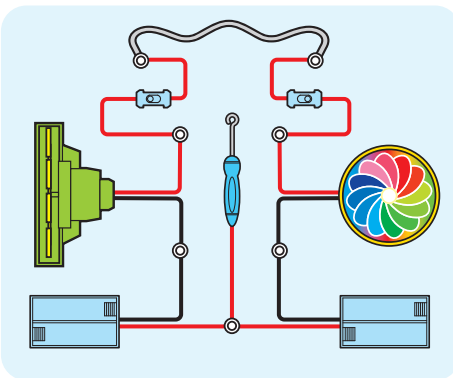
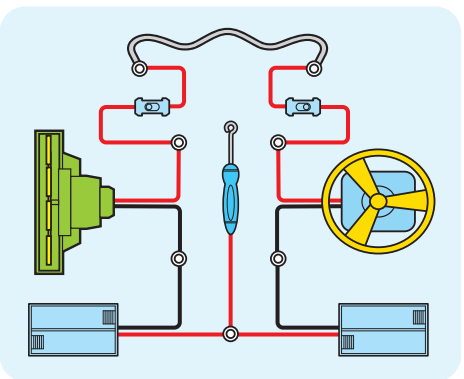
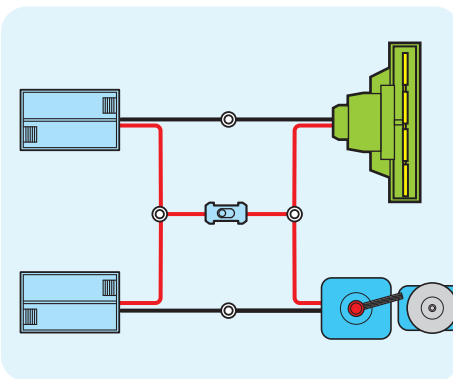
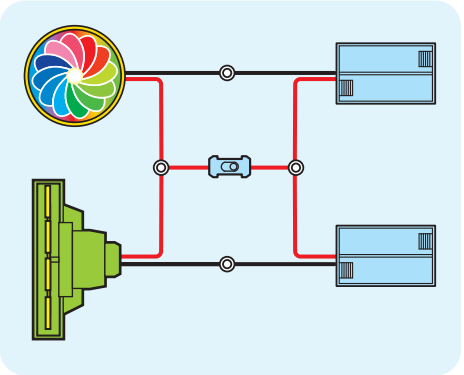
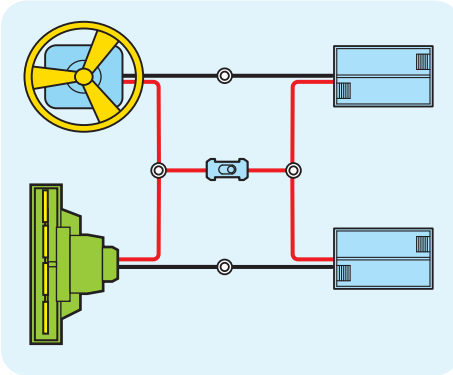
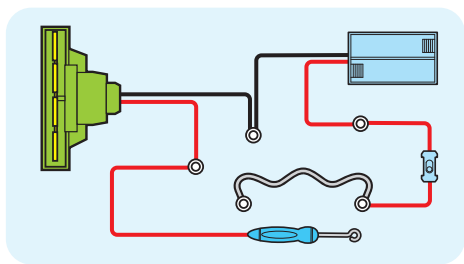
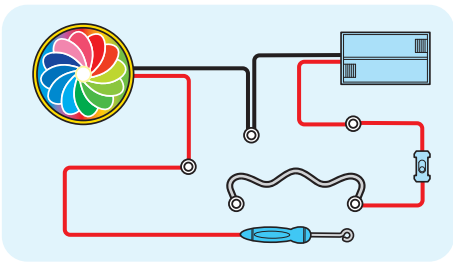

EDUCATIONAL HINTS

Series and Parallel connection

Note: For the purpose of demonstration, below diagrams are general electrical circuits in our daily life only. They are not circuits for Connex kits.

The circuit shows in fig.1 is a series circuit. It involves series connection.

As electricity flows in a single path, the current flow through each device will be the same. However, if any one of the device is broken, the circuit will be disconnect and cannot function.

FIG.1

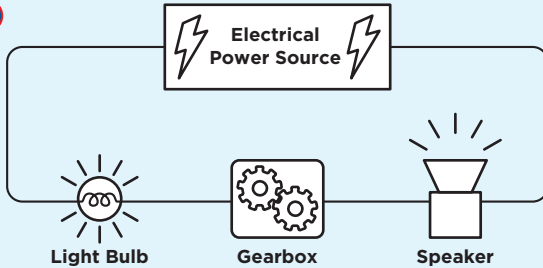

The circuit shows in fig.2 is a parallel circuit. It involves parallel connection.

Each electrical device is connected in parallel. If one device is broken, the other devices can still work.

FIG.2

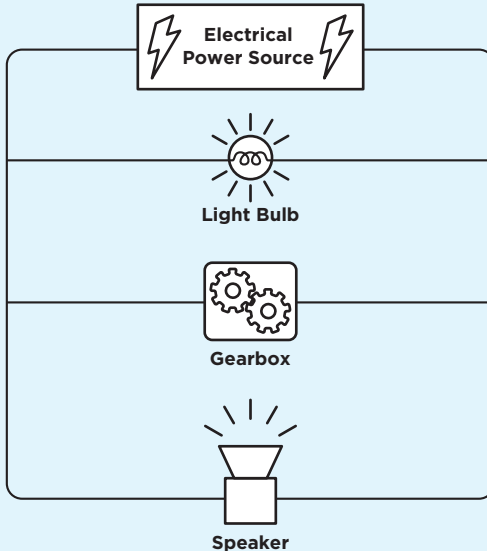

When you have skilled through this set, you can even design your own circuit to have different interesting play! The following is an example of creating an alternate 2in1 circuit for an alternate play effect:

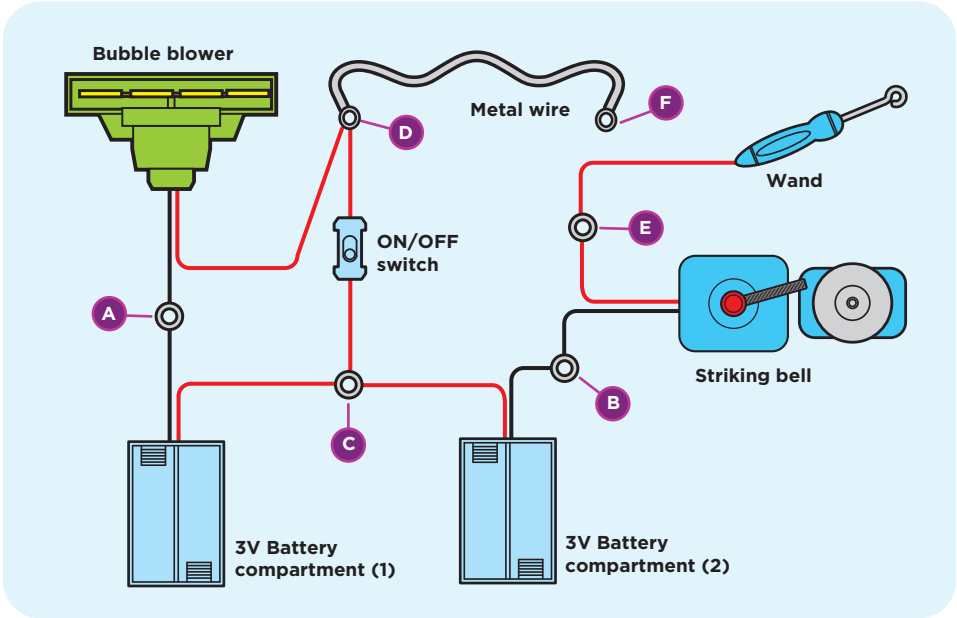

Wiring connections	Spring (A)	Spring (B)	Spring (C)	Spring (D)	Spring (E)	Spring (F)
3V Battery compartment (1)	black		red			
3V Battery compartment (2)		black	red			
ON/OFF switch			red	red		
Bubble blower	black			red		
Striking bell		black			red	
Wand					red	
Metal wire				silver		silver

Insert 4pcs AA batteries and switch on the ON/OFF switch. The bubble blower will blow continuous bubble stream immediately! Now challenge yourself with the maze challenge. Keep your hand steady and carefully move the ring of the wand through the metal wire. If the ring touches the metal wire, the bell will be triggered and you fail! Complete the maze before the bubble blower is running out of bubbles!



© 2021 Explore Scientific, LLC.
1010 S 48th Street, Springdale, AR 72762
explorescientificusa.com | 866.252.3811
All rights reserved. Made in China.



If at any time in the future you should need to dispose of this product please note that waste electrical products should not be disposed of with household waste. Please recycle where facilities exist. Check with your local authority or retailer for recycling advice. (Waste Electrical and Electronic Equipment Directive)