



# CF400SP TELESCOPE

**70 mm Telescope Pan Handle AZ Mount  
w/Smartphone Adapter  
Instruction Manual**



**WARNING:**  
**SUN HAZARD** – Never look directly at the sun  
with this device.



**WARNING:**  
**CHOKING HAZARD** – Small parts.  
Not for children under 3 years.



**CR2032**  
**51** **x1**  
**INCLUDED**



**WARNING:**  
Contains button or coin cell battery.  
Hazardous if swallowed – see instructions.



**WARNING:**  
The lens contains lead that may be harmful.  
Wash hands after touching.



**WARNING:**  
This product can expose you to chemicals including lead,  
which is known to the State of California to cause cancer  
and birth defects or other reproductive harm.  
For more information go to [www.P65Warnings.ca.gov](http://www.P65Warnings.ca.gov).

## IMPORTANT SAFETY INSTRUCTIONS

READ AND FOLLOW THE INSTRUCTIONS BEFORE USE.  
KEEP THESE INSTRUCTIONS FOR LATER USE.



• **SUN WARNING: WARNING: NEVER ATTEMPT TO OBSERVE THE SUN WITH THIS DEVICE! OBSERVING THE SUN – EVEN FOR A MOMENT – WILL CAUSE INSTANT AND IRREVERSIBLE DAMAGE TO YOUR EYE OR EVEN BLINDNESS.** EYE DAMAGE IS OFTEN PAINLESS, SO THERE IS NO WARNING TO THE OBSERVER THAT THE DAMAGE HAS OCCURRED UNTIL IT IS TOO LATE. DO NOT POINT THE DEVICE AT OR NEAR THE SUN. DO NOT LOOK THROUGH THE DEVICE AS IT IS MOVING. CHILDREN SHOULD ALWAYS HAVE ADULT SUPERVISION WHILE OBSERVING.

• **RESPECT PRIVACY:** WHEN USING THIS DEVICE, RESPECT THE PRIVACY OF OTHER PEOPLE. FOR EXAMPLE, DO NOT USE IT TO LOOK INTO PEOPLE'S HOMES.



• **CHOKING HAZARD:** CHILDREN SHOULD ONLY USE DEVICE UNDER ADULT SUPERVISION. KEEP PACKAGING MATERIALS LIKE PLASTIC BAGS AND RUBBER BANDS OUT OF THE REACH OF CHILDREN AS THESE MATERIALS POSE A CHOKING HAZARD.

• **RISK OF BLINDNESS:** NEVER USE THIS DEVICE TO LOOK DIRECTLY AT THE SUN OR IN THE DIRECT PROXIMITY OF THE SUN. DOING SO MAY RESULT IN A PERMANENT LOSS OF VISION.

• **RISK OF FIRE:** DO NOT PLACE DEVICE, PARTICULARLY THE LENSES, IN DIRECT SUNLIGHT. THE CONCENTRATION OF LIGHT RAYS COULD CAUSE A FIRE.

• **DO NOT DISASSEMBLE THIS DEVICE:** IN THE EVENT OF A DEFECT, PLEASE CONTACT YOUR DEALER. THE DEALER WILL CONTACT THE CUSTOMER SERVICE DEPARTMENT AND CAN SEND THE DEVICE IN TO BE REPAIRED IF NECESSARY.

• **DO NOT SUBJECT THE DEVICE TO TEMPERATURES EXCEEDING 60 °C (140 °F).**



• **DISPOSAL:** KEEP PACKAGING MATERIALS, LIKE PLASTIC BAGS AND RUBBER BANDS, AWAY FROM CHILDREN AS THEY POSE A RISK OF SUFFOCATION. DISPOSE OF PACKAGING MATERIALS AS LEGALLY REQUIRED. CONSULT THE LOCAL AUTHORITY ON THE MATTER IF NECESSARY AND RECYCLE MATERIALS WHEN POSSIBLE.



• THE WEEE SYMBOL IF PRESENT INDICATES THAT THIS ITEM CONTAINS ELECTRICAL OR ELECTRONIC COMPONENTS WHICH MUST BE COLLECTED AND DISPOSED OF SEPARATELY.

■ **NEVER DISPOSE OF ELECTRICAL OR ELECTRONIC WASTE IN GENERAL MUNICIPAL WASTE. COLLECT AND DISPOSE OF SUCH WASTE SEPARATELY.**

• MAKE USE OF THE RETURN AND COLLECTION SYSTEMS AVAILABLE TO YOU, OR YOUR LOCAL RECYCLING PROGRAM. CONTACT YOUR LOCAL AUTHORITY OR PLACE OF PURCHASE TO FIND OUT WHAT SCHEMES ARE AVAILABLE.

• ELECTRICAL AND ELECTRONIC EQUIPMENT CONTAINS HAZARDOUS SUBSTANCES WHICH, WHEN DISPOSED OF INCORRECTLY, MAY LEAK INTO THE GROUND. THIS CAN CONTRIBUTE TO SOIL AND WATER POLLUTION WHICH IS HAZARDOUS TO HUMAN HEALTH, AND ENDANGER WILDLIFE.

• IT IS ESSENTIAL THAT CONSUMERS LOOK TO RE-USE OR RECYCLE ELECTRICAL OR ELECTRONIC WASTE TO AVOID IT GOING TO LANDFILL SITES OR INCINERATION WITHOUT TREATMENT.

 **BUTTON/COIN BATTERY WARNING:** THIS PRODUCT CONTAINS A BUTTON OR COIN CELL BATTERY. A SWALLOWED BUTTON OR COIN CELL BATTERY CAN CAUSE INTERNAL CHEMICAL BURNS IN AS LITTLE AS TWO HOURS AND LEAD TO DEATH. DISPOSE OF USED BATTERIES IMMEDIATELY. KEEP NEW AND USED BATTERIES AWAY FROM CHILDREN. IF YOU THINK BATTERIES MIGHT HAVE BEEN SWALLOWED OR PLACED INSIDE ANY PART OF THE BODY, SEEK IMMEDIATE MEDICAL ATTENTION.



## Parts Overview

1. 70mm Objective Lens
2. Pan- Tilt Alt-Azimuth Mount
3. Tripod with Accessory Tray
4. Optical Tube Assembly with Dew Shield
5. Focus Wheel
6. 45° Erecting Prism Diagonal
7. 1.25" Eyepieces (K6 mm & K20 mm)
8. Red Dot Viewfinder
9. Smartphone Adapter

**Available Downloads Visit:**

[www.esmanuals.com](http://www.esmanuals.com)



## How To Set Up

### Assembly:

*Note: We recommend assembling your telescope for the first time in the daylight or in a lit room so that you can familiarize yourself with assembly steps and all components.*

1. Open the tripod until the tripod spreaders are fully extended. Put the accessory tray in place and turn it clockwise until stable. To set the tripod height, turn the pressure fitting on each leg counterclockwise until loose. Extend or retract the leg to the desired setting, then tighten the pressure fitting until snug.
2. Thread the panhandle clockwise onto the tripod head.
3. Set the optical tube assembly on the tripod head and align the tab on the bottom of the telescope tube with the slot in the tripod head. Thread the front tension wheel until snug, then tighten the side tension thumbscrew. Be careful not to over-tighten either thumbscrew.
4. Insert the diagonal into the focuser and secure it by tightening the thumbscrews.
5. To install the bracket for the red dot viewfinder, remove the two metal thumbscrews on the top of the telescope tube. Place the bracket in position over the holes, replace the thumbscrews and tighten until secure. Be careful not to over-tighten either thumbscrew.
6. After installing the bracket, slide the red dot viewfinder into the bracket and secure it by tightening the three screws around the ring.
7. Place your chosen eyepiece into the diagonal. We recommend starting with the 20mm because it will provide the widest field of view.

### Telescope Terms To Know:

**Diagonal:** A mirror that deflects the ray of light 90 degrees.

With a horizontal telescope tube, this device deflects the light upwards so that you can comfortably observe by looking downwards into the eyepiece. The image in a diagonal mirror appears upright, but rotated around its vertical axis (mirror image).

**Focal length:** Everything that magnifies an object via an optic lens has a certain focal length. The focal length is the length of the path the light travels from the surface of the lens to its focal point. The focal point is also referred to as the focus. In focus, the image is clear. In the case of a telescope, the focal length of the telescope tube and the eyepieces are used to determine magnification.

**Lens:** The lens turns the light that falls on it around in such a way so that the light gives a clear image in the focal point after it has traveled a certain distance (focal length).

**Eyepiece:** An eyepiece is a system made for your eye and comprised of one or more lenses. In an eyepiece, the clear image that is generated in the focal point of a lens is captured and magnified still more.

**Magnification:** The magnification corresponds to the difference between observation with the naked eye and observation through a magnifying device like a telescope. If a telescope configuration has a magnification of 30x, then an object viewed through the telescope will appear 30 times larger than it would with the naked eye. To calculate the magnification of your telescope setup, divide the focal length of the telescope tube by the focal length of the eyepiece.

**NOTE:**

The magnifying power of a telescope is determined by dividing the focal length of the telescope by the focal length of the eyepiece. This means that as the focal length of your eyepiece increases, the magnifying power decreases.

**Using/Aligning the Red Dot Viewfinder:**

The viewfinder is powered by a CR-2032 battery that is included. Before using the viewfinder for the first time, remember to remove the plastic insulator that is blocking the battery from connecting.

When it is time to replace the battery, remove the battery cap by loosening the set screw. Take out the old battery and slide a new battery in place with the positive side showing. Replace the cap, and tighten the set screw.

**For The Viewfinder To Be Effective, It Must Be Aligned.**

**To do this:**

- Insert the 20 mm eyepiece into the diagonal and power on the viewfinder by sliding the switch on its right side to an "On" position.
- Point the eyepiece at an easy to identify target like a telephone pole that is approximately 200 yards away. Center the object in the eyepiece. Lock the telescope into place by tightening the panhandle.
- Without moving the telescope, position the red dot using the two adjustment screws so that it shares the same view as the one in your eyepiece. The front screw will move the viewfinder up and down, and the other will move it side to side. Your viewfinder is now aligned.

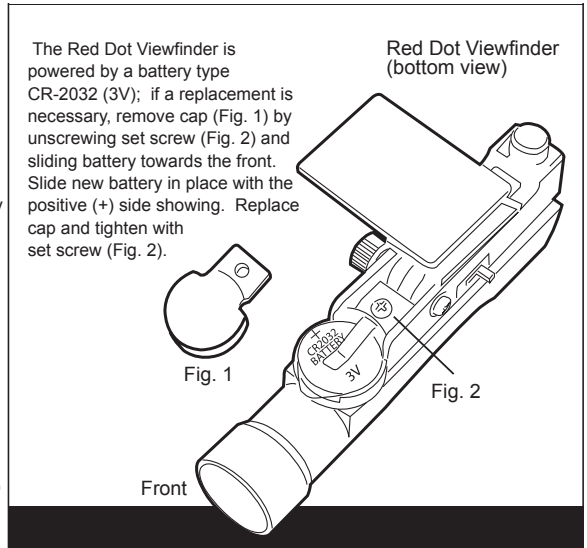

*Note: To preserve battery life, don't forget to turn off the viewfinder after use.*

**Using Your Telescope:**

After you have assembled your telescope, you are ready to start observing. Put the 20mm eyepiece into the diagonal to get the widest field of view. This wider field of view will make it easier to locate and track objects.

To move the scope up, down and side to side, loosen the locking screws slightly and grip the telescope near where the tube meets the focuser and steadily move the tube until your target comes into view in the eyepiece. Once you have found and focused on your desired target, you can lock the telescope into position by tightening the two locating screws.

It is important to remember that the rotation of the Earth means objects will move out of your eyepiece fairly quickly.

For a closer look at an object, you can insert the K6 mm eyepiece. The magnification will increase from 20x to 67x.

### Cleaning:

Your telescope is a precision optical device and keeping the optics free of dust and dirt is crucial for optimal performance. To clean the lenses (objective and eyepiece) use only a photo-grade soft brush or a lint-free cloth, like a microfiber cloth. Do not press down too hard while cleaning, as this might scratch the lens. Ask your parents to help if your telescope is really dirty. If necessary, the cleaning cloth can be moistened with an optical glass cleaning fluid and the lens wiped clean using very little pressure. Do not use harsh detergents!

Make sure your telescope is always protected against dust and dirt. After use, leave it in a warm room to dry off before storing.

### Possible Objects For Observation:

#### Terrestrial Objects

Take note of the examples below, including Mount Rushmore and the golf course. Start with the K20 mm eyepiece and focus until the image is clear. After mastering the K20 mm eyepiece, switch to the K6 mm eyepiece and practice scanning and focusing until the image is clear. Choose several terrestrial objects to practice focusing on, but never point your telescope at or near the sun, or you risk blindness.

#### Terrestrial Images

f=K20 mm

f=K6 mm



#### The Moon

**Diameter:** 3,476 km

**Distance:** Approximately 384,401 km

The Moon is the Earth's only natural satellite, and it is the second brightest object in the sky (after the Sun). Although it is our closest neighbor, a lot of people have never really taken a good long look at the Moon. With your telescope, you should be able to see several interesting lunar features. These include lunar maria, which appear as vast plains, and some of the larger craters. The best views will be found along the terminator, which is the edge where the visible and cloaked portions of the Moon meet.

#### The Moon

f=K20 mm

f=K6 mm



### Troubleshooting Guide:

Problem	Solution
No picture	Remove dust protection cap and sun-shield from the objective opening.
Blurred picture	Adjust focus using focus ring.
No focus possible	Wait for temperature to balance out.
Bad quality	Never observe through a glass surface such as a window.
Viewing object visible in the finder, but not through the telescope	Align finder to telescope (see instructions)
Despite using star diagonal prism the picture is "crooked"	The star diagonal prism should be vertical in the eyepiece connection.

## Using the Smartphone Adapter:

### SUPERVISION BY ADULTS

Read and follow the instructions, safety rules and first aid information

The Smartphone Adapter will allow you to connect almost any “smart” device to a 1.25” eyepiece. To use the adapter, place it directly onto the selected eyepiece and secure it by tightening the setscrew until snug. Be careful not to overtighten because this could damage the adapter and/or the eyepiece.

The camera lens on your smart device will need to be centered over the eyepiece. This alignment is best done by opening the camera function and viewing the image while you center the device. Once you have positioned the device correctly, carefully press it onto the suction cup/non-skid surface of the adapter pad. Never allow the adapter pad to hold your device without you supporting the item as well.

The point at which you secure the eyepiece/adapter combination into the diagonal depends largely on the dimensions of your device. For smaller devices like smart phones, it may be easier to secure it to the eyepiece/adapter combination before inserting the entire unit into the diagonal on the telescope. For larger devices, such as tablets, it may be easier to secure the eyepiece/adapter combination into the diagonal, and then align and attach your device.

After positioning your device and capturing images, you can enhance and edit the photos using the imaging software of your choice. One option can be found at <https://www.getpaint.net/>.

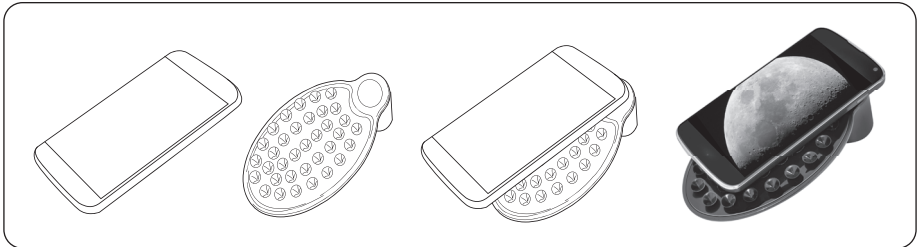

**WARNING:** Do not leave your device unsupported or unattended on the adapter pad.

Though the surface of the adapter pad is designed with suction cups and is non-skid, the manufacturer cannot assure that the pad will support the weight of various devices or guarantee that it will adhere to all surfaces on various smart devices. The pad is not intended to secure, balance or support the device on its own, and the operator should not let the device rest solely on the adapter pad. Leaving the device unattended or allowing it to balance on its own without operator support may result in the device falling, unbalancing the entire instrument and possibly damaging the telescope or your smart device.

### CHEMICALS

Any chemicals and liquids used in preparing, using, or cleaning should be kept out of reach of children. Do not drink any chemicals. Hands should be washed thoroughly under running water after use. In case of accidental contact with the eyes or mouth rinse with water. Seek medical treatment for ailments arising from contact with the chemical substances and take the chemicals with you to the doctor.

## Observing Tips:

### Star hopping

Star hopping is a technique used by amateur astronomers to navigate the night sky. By using easily recognizable constellations and asterisms as a guide, an observer can locate stars and other objects.

For example, Polaris, which is commonly referred to as The North Star, can be located quickly using star hopping. First, find the Big Dipper asterism in the Ursa Major constellation. The popular pattern is defined by seven stars, and the two stars on the front edge of the Big Dipper's "bowl" are Merak and Dubhe. Next, draw an imaginary line from the bottom star (Merak) on this front edge through the top star (Dubhe) on the front edge. Follow the line to the first bright star you see. That should be Polaris. Finally, to verify your finding, locate the Little Dipper asterism. Polaris is the anchor star at the end of the Little Dipper's "handle."

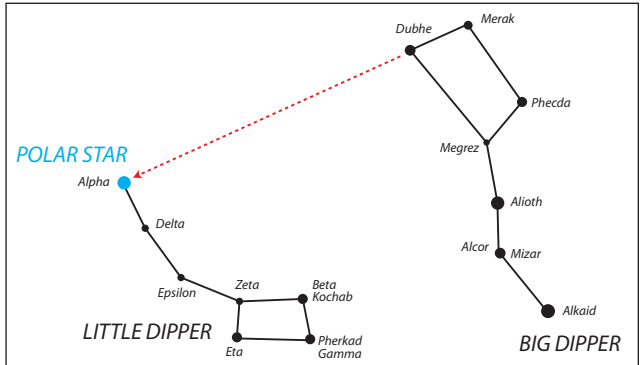

**Note:** The positioning of the Big Dipper in relation to the Little Dipper does not change, but the orientation of both in the night sky will rotate throughout the year due to the motion of the Earth.

## Possible Objects for Observation:

What you can observe at any one time in your telescope depends on several factors beyond aperture and magnification. These factors include location, date, time and sky conditions. The following are all objects that can be seen with the unaided eye and/or binoculars. Your telescope can enhance views of any of these objects if the observing conditions are right.

### The Moon:

**Diameter:** 3,476 km

**Distance:** Approximately 384,401 km

The Moon is the Earth's only natural satellite, and it is the second brightest object in the sky (after the Sun). Although it is our closest neighbor, a lot of people have never really taken a good long look at the Moon. With your telescope, you should be able to see several interesting lunar features. These include lunar maria, which appear as vast plains, and some of the larger craters. The best views will be found along the terminator, which is the edge where the visible and shadowed portions of the Moon meet.



Image credit: Howard Eskildsen



### Orion Nebula (M42):

**Right ascension:** 05: 35.4 (hours: minutes)

**Declination:** -05: 27 (degrees: minutes)

**Distance:** Approximately 1,344 light years

The Orion Nebula is a vast star-forming region located in the "sword" branching off of the famous Orion's Belt. Also known as Messier 42, this diffuse nebula is bright enough to see with the unaided eye — although it will only appear as a slightly foggy star. However, with your telescope, you can see many of the beautiful details, such as the billowing clouds of gas and dust where new stars are being born.

Image credit: NASA, ESA, M. Robberto (Space Telescope Science Institute/ESA) and the Hubble Space Telescope Orion Treasury Project Team

**Note:** Images are for illustration purposes only. Quality of your image may vary depending upon atmospheric conditions and location.



**Pleiades Star Cluster(M45):**

**Right ascension:** 03: 47.0 (hours: minutes)

**Declination:** +24: 07 (degrees: minutes)

**Distance:** Approximately 444 light years

The Pleiades Star Cluster is a group of brilliant blue stars located in the Taurus Constellation. Also known as Messier 45 or "Seven Sisters", this open star cluster consists of more than 1,000 confirmed stars, although an average of only six are visible to the unaided eye. With your telescope, you can quickly reveal some of the more elusive members of this legendary and beautiful cluster.



Image credit: NASA/JPL-Caltech/UCLA



Image credit: NASA/JPL-Caltech

**Andromeda Galaxy(M31):**

**Right ascension:** 00: 42.7 (hours: minutes)

**Declination:** +41: 16 (degrees: minutes)

**Distance:** Approximately 2.54 million light years

The Andromeda Galaxy is the closest major galaxy to our own Milky Way. Also known as Messier 31, this famous spiral galaxy is part of the Local Group of galaxies. Although it is technically bright enough to see with the unaided eye under a very dark sky, your telescope may show its bright center, hints of its spiral structure and its much smaller companion galaxies known as M32 and M110.

**Dumbbell Nebula(M27)**

**Right ascension:** 19:59.6 (hours: minutes)

**Declination:** +22:43 (degrees: minutes)

**Distance:** Approximately 1,360 light years

The Dumbbell Nebula was the first planetary nebula ever discovered. It is one of the most popular sights in the Vulpecula constellation. Easy to find with binoculars and amazing in a telescope, the shape of this bright, double-lobed nebula has been compared to a dumbbell, an hourglass or an apple core. As an added bonus, the white dwarf that lies at the heart of the Dumbbell Nebula is larger than any other star of its kind.



Image credit: NASA/JPL-Caltech/Harvard-Smithsonian CfA

**Note:** Images are for illustration purposes only. Quality of your image may vary depending upon atmospheric conditions and location.

## Types Of Telescopes:

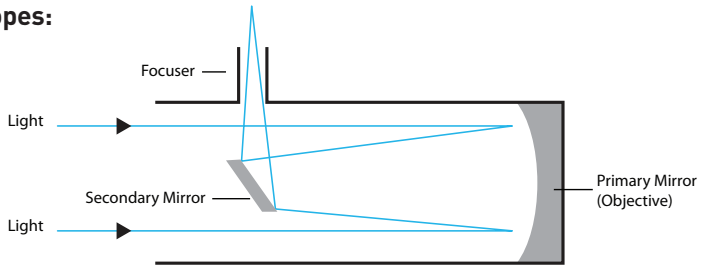

### Reflector

A reflector telescope uses mirrors to gather and focus light. Light enters the telescope through its open front end and travels to the concave primary mirror at the back. From there the light is reflected back up the tube to a flat secondary mirror, which sits at a 45° angle in relation to the eyepiece. Light bounces off of this secondary mirror and out through the eyepiece. A reflector telescope is designed for astronomical use. Terrestrial objects may appear inverted, sideways or at an angle depending on how your tube is oriented due to optical design. This rotation is perfectly normal on all Newtonian reflectors and will not affect astronomical viewing.

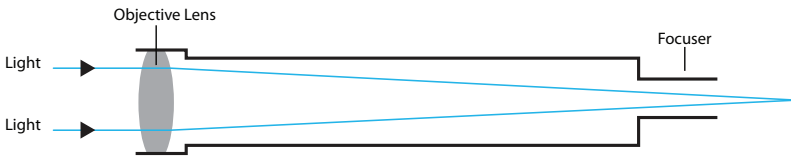

### Refractor:

A refracting telescope uses a collection of lenses to gather and focus light. A refractor's views will be upside down if a diagonal is not in use. A standard diagonal will generate a "right side up" image, however, it will rotate the image on the vertical axis (mirror image). To get the "right side up" image without the rotation, you will need to use a special diagonal with an erect image prism.

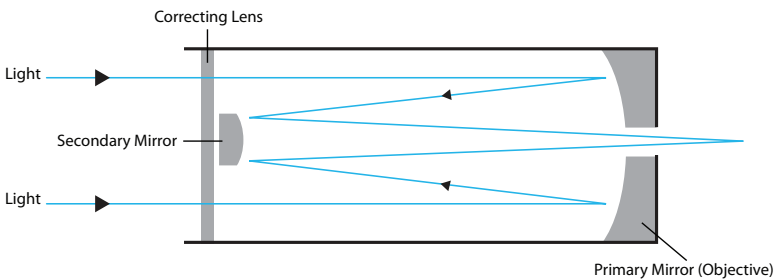

### Catadioptric:

A catadioptric telescope uses a combination of mirrors and lenses to gather and focus light. Popular catadioptric designs include the Maksutov-Cassegrain and Schmidt-Cassegrain.

## Telescope Terms to Know:

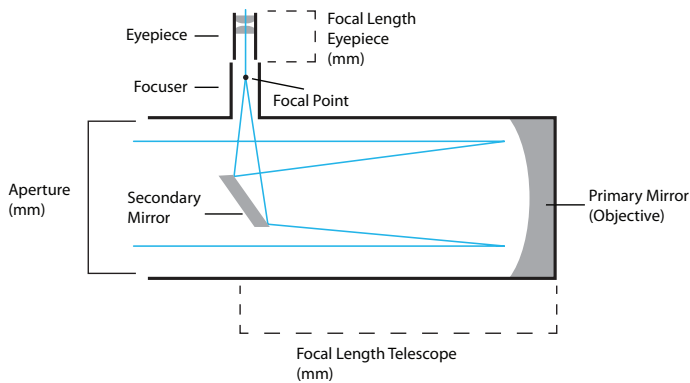
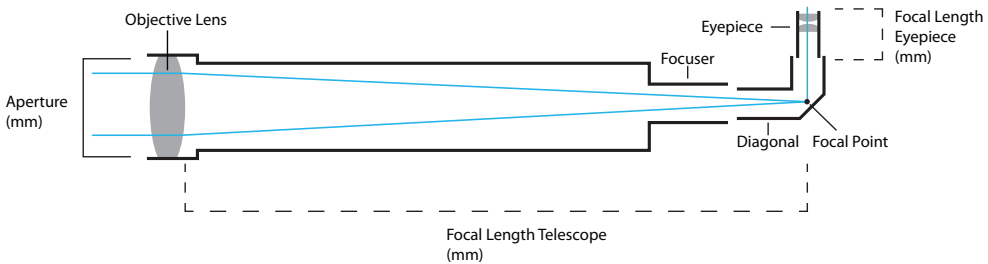

### Aperture:

This figure, which is usually expressed in millimeters, is the diameter of a telescope's light-gathering surface (objective lens in a refractor or primary mirror in a reflector). Aperture is the key factor in determining the brightness and sharpness of the image.

### Objective Lens:

The objective lens is the main light-gathering component of a refractor telescope. It is actually composed of several lens elements.

### Diagonal:

This accessory houses a mirror that deflects the ray of light 90 degrees. With a horizontal telescope tube, this device deflects the light upwards so that you can comfortably observe by looking downwards into the eyepiece. The image in a standard diagonal mirror appears upright, but rotated around its vertical axis (mirror image). To get an image without this rotation, you will need to use a special diagonal with an erect image prism.

### Eyepiece:

An eyepiece is an optical accessory comprised of several lens elements. It determines the magnification of a particular observing setup.

### Primary Mirror:

The primary mirror is the principle light-gathering surface of a reflector telescope.

### Secondary Mirror:

A secondary mirror is a small mirror that sits at a 45° angle in relation to the primary mirror of a reflecting telescope. Light from the primary mirror is reflected back up the tube to the secondary mirror. The light is directed from this mirror up into the eyepiece.

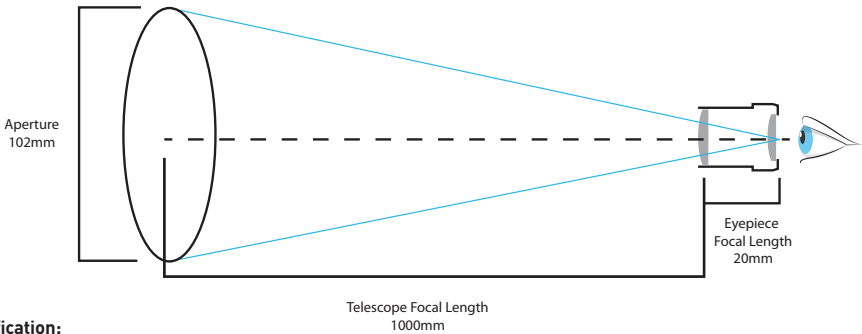

**Magnification:**

The magnification corresponds to the difference between observation with the naked eye and observation through a magnifying device like a telescope. If a telescope configuration has a magnification of 30x, then an object viewed through the telescope will appear 30 times larger than it would with the naked eye. To calculate the magnification of your telescope setup, divide the focal length of the telescope tube by the focal length of the eyepiece. For example, a 20mm eyepiece in a telescope with a 1000mm focal length will result in 50x power, which will make the object appear 50 times larger. If you change the eyepiece, the power goes up or down accordingly.

$$\text{Magnification} = \frac{\text{Telescope Focal Length}}{\text{Eyepiece Focal Length}}$$

**Focal ratio**

The focal ratio of a telescope is determined by dividing the telescope's focal length by its aperture (usually expressed in millimeters). It plays a key role in determining a telescope's field of view and significantly impacts imaging time in astrophotography. For example, a telescope with a focal length of 1000mm and a 100mm clear aperture has a focal ratio of f/10.

$$\text{Focal Ratio} = \frac{\text{Telescope Focal Length}}{\text{Telescope Aperture}}$$

**Focal length (Telescope):**

The focal length is the distance in millimeters between the objective lens or primary mirror and the point at which entering light rays converge — otherwise known as the focal point. The focal lengths of the telescope tube and the eyepiece are used to determine magnification.

**Focal length (Eyepiece):**

The focal length is the distance in millimeters between the center of the first lens element in an eyepiece and the focal point. The focal lengths of the telescope tube and the eyepiece are used to determine magnification. Short eyepiece focal lengths produce higher magnifications than long eyepiece focal lengths.

**Exit Pupil**

The exit pupil is the diameter of the beam of light coming out of the eyepiece. To calculate exit pupil, divide the focal length of your eyepiece by your telescope's focal ratio. For example, if you use a 20mm eyepiece with an f/5 telescope, the exit pupil would be 4mm.

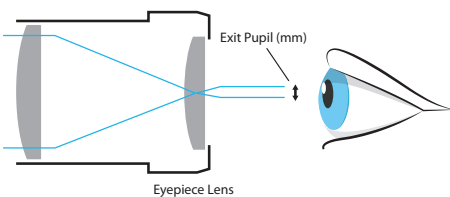

$$\text{Exit Pupil} = \frac{\text{Eyepiece Focal Length}}{\text{Telescope Focal Ratio}}$$

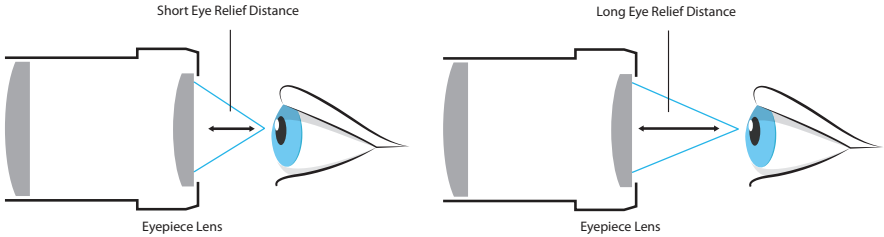

### Eye Relief

Eye relief is all about a comfortable viewing experience because it is the distance at which you need to position your eye from the eyepiece's outermost surface to enjoy the full field of view. This characteristic is of special concern to observers who wear glasses to correct an astigmatism, because a long enough eye relief is necessary to allow room for glasses.

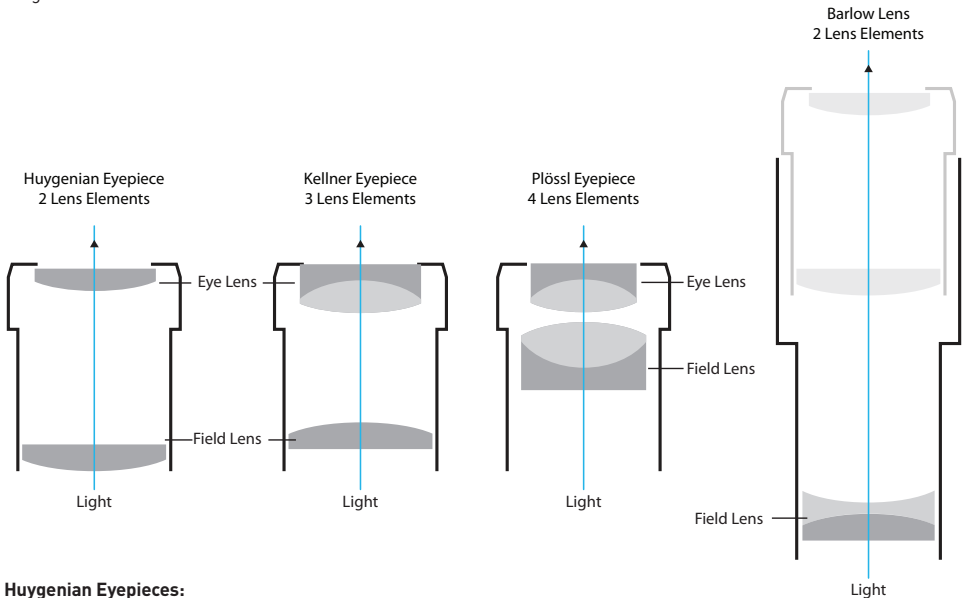

### Huygenian Eyepieces:

A Huygenian eyepiece uses two plano-convex lenses separated by an air gap. They have a fairly narrow apparent field of view.

### Kellner Eyepieces:

A Kellner eyepiece uses three lens elements - two of which are paired together in an achromatic doublet design to minimize chromatic aberrations. They typically produce an apparent field of view around 45°.

### Plössl Eyepieces:

A Plössl eyepiece uses two doublets (a pairing of lens) for a total of four lens elements. This eyepiece design delivers sharp views and an apparent field of view of approximately 50°, which works well for both planetary and deep sky viewing.

### Barlow Lens:

A Barlow lens effectively increases the focal length of a telescope. It is inserted between the eyepiece and the focuser/diagonal (depending on the optical setup) and multiplies the magnification power of the eyepiece. For example, a 2x Barlow will double the magnification of a particular eyepiece.



## NOTES

**NOTES**



©2020 Explore Scientific, LLC., Explore One  
1010 S 48th Street, Springdale, AR 72762  
explorescientificusa.com | 866.252.3811  
All rights reserved. Made in China.

CONTENTS AND COLORS MAY VARY  
CONFORMS TO THE SAFETY REQUIREMENTS OF ASTM F963