

EXPLORE[®]

SCIENTIFIC

We would like to thank you for selecting an Explore Scientific[®] telescope as your pathway to the stars.

Since 2008, Explore Scientific has been on a mission to make astronomy accessible and provide a truly transformative experience by giving people the tools and guidance they need to explore the skies.

With our high-end optics and well-executed design, our precision optical instruments enhance your observing experience by rising to the highest standards of clarity, contrast and functionality. We also aim to exceed your service expectations by providing our Explore STAR Warranty that guarantees an unprecedented level of satisfaction.

We think of our telescopes as more than products. They are gateways to the universe that will broaden your perspective by revealing the intricate beauty of our nearest neighbors as well as the bounty of celestial wonders that lie well beyond our humble solar system.

The adventures this telescope can send you on are immeasurable, and we encourage you to enjoy it fully, use it often and share with others. All of us at Explore Scientific[®] want you to have the experience you deserve, so please do not hesitate to contact our Customer Service Center with your questions or suggestions through an online chat at www.explorescientificusa.com or by calling (866) 252-3811.

Clear skies,



Scott Roberts
President and Founder
Explore Scientific[®], LLC

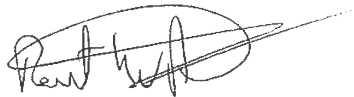

Robert Price
COO
Explore Scientific[®], LLC

TABLE OF CONTENTS

AR DOUBLET SERIES – PG 2

ED TRIPLET ESSENTIAL SERIES – PG 6

CARBON FIBER SERIES – PG 10

EYEPIECES – PG 14

FINDERSCOPIES – PG 20

FOCUSERS – PG 23

TWILIGHT SERIES MOUNTS – PG 26

SHARE THE SKY – PG 30

Welcome to Our AR Doublet Series

Designed to deliver crystal clear imagery full of contrast, the telescopes in our AR Doublet Series will reveal the universe's breathtaking sights with rich detail. Available in three apertures ranging from a highly portable 102 mm to a far-reaching 152mm, these achromatic refractors produce stunning views of countless celestial treasures like the Moon's chiseled craters, Saturn's elegant rings or the churning spiral of the face-on Pinwheel Galaxy. To connect you with the cosmos, the doublet telescopes in this series use a pairing of a crown glass lens and a flint glass lens separated by a cushion of air to minimize chromatic aberrations. To further guarantee high-quality imagery, all optical glass is fully multi-coated. Each model also offers a three-point collimation cell that allows for pinpoint adjustments of the objective lens for precision performance. Your AR Doublet Series telescope offers all of these benefits and more. This set-up manual and the accompanying materials will guide you through a basic assembly process that will have you at the eyepiece and under the stars in no time.



Sun Warning

DO NOT USE this telescope or any accompanying finder scope to look at or near the Sun! Even momentary visual contact with the Sun's light rays can instantly cause irreversible damage to your eye(s). Eye damage can be painless, so there is no warning to the observer that damage has occurred until it is too late.

Take extra care when using the telescope or a finder scope during daylight hours, and do not point either at or near the Sun. Do not look through either when you are moving the instruments during the daytime. Never allow anyone to use the telescope or a finder scope during the daytime without warning them of the hazards of aiming either at or near the Sun. Make sure that they are adequately trained on the use of these instruments before allowing them to start observing. Children should always have informed and trained adult supervision while observing.

Proper Care Warning

Your telescope is a precision optical device and keeping the optics free of dust and dirt is crucial for optimal performance. However, the use of improper cleaning techniques, tools and/or solutions can cause irreparable damage to your telescope. In terms of solutions, use distilled water and/or an optical glass cleaner that can be found at most camera stores. Only use pure cotton swabs/balls or white, unscented, lotion-free tissues for wiping down optics after you have removed as many particles as possible with forced air or a photographic-grade camel hair brush. DO NOT use optical lens cleaning tissues as many contain fiberglass particles that can be abrasive.

Unpacking and Moving

Please Note: We recommend that you keep the original shipping box and packing materials if possible, in case your scope should ever need to be returned for service or warranty purposes. When the box is opened for the first time, you will find that all parts are packaged in plastic bags and the telescope's tube is wrapped in tissue. To begin assembly, slowly remove the optical tube. All models will come with their cradle rings attached, which makes for easy removal. Rarely, the cradle could have come open during packing or shipping, so it is important to check the latches and then do a quick, small lift by the cradle handle to make sure the ring is secure before pulling the instrument all the way out. Although our telescopes are designed with portability in mind, it is important to use proper lifting techniques to prevent back injury and/or strained muscles. Whenever possible, use two people to move or lift the equipment and make use of wheeled devices like carts or dollies for additional aid.

Dew Shield

The dew shield is an important part of your telescope because it slows moisture build-up on the objective lens and can reduce image interference caused by ambient light. On each model in this series, the dew shield is pre-attached.

Diagonal

Astronomical observation usually requires the telescope to tilt up significantly, which can make straight-thru viewing awkward and uncomfortable. A diagonal solves this comfort problem by using a mirror to direct the light at a 90° angle toward the eyepiece, which is positioned perpendicular to the optical tube assembly (OTA) making the image more accessible. Equipped to fit both 1.25" and 2" eyepieces, your telescope's diagonal houses a precision-polished, two-inch mirror that is 99% reflective to maximize light transmission. To install the diagonal, begin by removing the dust covers from the focuser's drawtube and the diagonal itself. Loosen the screws on the drawtube's tension collar, and slide the barrel of the diagonal into the drawtube. Tighten the three tension screws to secure it firmly. Should one of these tension screws accidentally become loose, the barrel of the diagonal is tapered to prevent it from falling out of the focuser. The 1.25" eyepiece adapter or 2" eyepieces can be secured in the diagonal by tightening the tension screws on the compression ring lock. The 1.25" adapter also has a compression ring to secure eyepieces that are inserted into it.

Cradle Rings

Please note: On our 102mm AR Doublet Achromatic Refractor, you will need to install the finder scope before you put on the cradle ring assembly. On all of our other telescope models, the finder scope can be installed after the cradle rings are in position.

To attach any of the AR Doublet models to a mount you will need to use the individual model's included cradle ring set. Engineered to snugly grip its particular telescope, each extruded aluminum cradle assembly includes a hinged ring system, a slotted carry handle and a felt-lined interior that protects the tube's delicate surface. The rings are attached to a dovetail saddle plate to secure your scope to a mount. To attach cradle rings to your OTA, release the locking mechanism on each ring by loosening the metal thumbscrews and then separate the rings. Position your OTA within the rings, close them and retighten the thumbscrews until the tube is secure. If you are only repositioning the tube, you probably will not need to remove the assembly completely. Instead, you can undo the lock on each ring so that the tube is loose enough in the rings to slide back and forth or rotate. Be careful to hold the tube securely so that you do not lose control of it while the cradle rings are loose. Once the tube is in the desired position, be sure to retighten each lock. Finding the right placement of the cradle ring assembly involves finding your individual scope's balance point, which depends largely on the accessories you will be using. Before attempting to find this point, you should make sure the diagonal and/or any heavy attachments like cameras or large eyepieces are installed. You may need to make adjustments for cone error if you are using a German equatorial mount. Cone error occurs when the polar axis of your mount and the center of your telescope's optical axis are not aiming at the same point in the sky. To check for cone error, you will need to first line your mount up with a fairly fixed point in the sky like Polaris or a stationary terrestrial target that will be far enough away to see well in your telescope. Mount your telescope and see if it is centered on the same target. If it is not, you will need to take the scope off of the mount and slightly tilt the telescope tube away from or toward the saddle plate by threading the adjusting screws in or out. These screws flank a central locking screw on each end of the saddle plate. The process will take some trial and error before the perfect adjustments are found. Please note that when the final adjustments are made, the center locking screw must have enough engagement with the threads of the cradle ring to make sure that the saddle plate stays connected.

Finder Scope

Please note: On our 102mm AR Doublet Achromatic Refractor, you will need to install the finder scope before you put on the cradle ring assembly. On all of our other telescope models, the finder scope can be installed after the cradle rings are in position.

Each scope in our AR Doublet Series comes with a non-illuminated straight finder scope: This classic reverse-view finder scope has a simple crosshair that can be centered on your target. The first step in mounting your finder scope to your telescope is to slide it into the finder scope bracket, which has two rings to hold your finder scope in place. Each of these rings has three adjusting screws. If your finder scope is not already installed in the bracket, loosen each of the adjusting screws until you have opened up the full inside diameter of the rings. Slide the finder scope into place and gently tighten all of the adjusting screws until your

finder scope is secure. The bracket has a dovetail base that slides easily into the mounting assembly that is already attached to the optical tube assembly (OTA). Once it is installed in the base, secure it by tightening the two large, heavy-duty plastic screws. For information on aligning your finder scope and telescope, please refer to the finder scopes pamphlet.

Figure 1

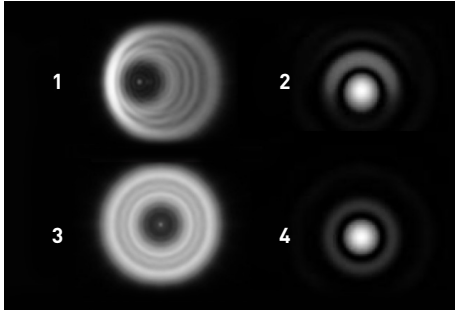

Defocused and focused out-of-collimation star images (1 and 2)

Defocused and focused properly collimated star images (3 and 4)

Collimation

Aligning the optics in your Explore Scientific AR Doublet Series telescope (a process called “collimation”) is a technical process that was performed by trained personnel in our quality control department. With proper care (such as transporting your telescope in its original shock-resistance packaging) your telescope can provide years of enjoyment without additional adjustments.

(Unlike REFLECTING style telescopes whose large, loosely-held mirrors need frequent adjustments, your REFRACTING style telescope contains a cell of lenses that is firmly locked in position.) If, however, the optical alignment in your telescope should require adjustment, we do not require that you return your telescope to our technicians for service, but we do recommend that the process be performed by an experienced, knowledgeable person.

To check the alignment of the optics in your telescope, find a bright star with your lowest power eyepiece and center it in the field of view. Next, change to a high power eyepiece and defocus the image slightly until you see a ring pattern similar to #3 in Figure 1. Now bring the image to its sharpest focus. Doing so should reveal your target star as a bright tiny dot (called the Airy disk, named after George Biddell Airy) surrounded by one or more rings (called the Airy pattern) that look similar to #4 in Figure 1. If the images in your eyepiece reflect the same symmetry depicted in #3 and #4 in Figure 1, the optics in your telescope are properly aligned.

However, if the image in your eyepiece looks more like #1 or #2 in Figure 1, re-collimating your telescope is recommended. For this purpose, the objective lenses in your telescope are mounted in a cell that is equipped with a collimation system consisting of three pairs of screws. Each pair of screws is called a collimation set and consists of one adjusting screw and one locking screw. These screws are accessible at the front of your telescope around the edge of the objective lens cell. Within each collimation set, the locking screw is the one that protrudes farther out from the bracket around the lens cell. To turn these screws you will need a 3mm hex wrench (although some AR127s require a #3 Phillips screwdriver).

To begin the collimation process, remove or retract the dew shield (depending on the model of your telescope) and take off the dust cover to access the screws in the collimation system. Using a low-power eyepiece, center a bright star in the field of view. Replace the low-power eyepiece with a high-power eyepiece and defocus the image until the star develops distinct rings. Be careful not to defocus the image so far that you lose sight of the rings. Your goal now is to make the defocused image appear symmetrical (as in #3 in Figure 1) by making adjustments in one or more of the collimation sets.

To make an adjustment, loosen the locking screw in one of the collimation sets and then turn the adjusting screw a quarter turn in or out. Gently re-secure the locking screw, being careful not to over-tighten.

Recheck the image to see how it was affected by the adjustment you made. By repeating this process determine which adjustments make the defocused image more and more symmetrical. Once your image looks like #3 in Figure 1, your telescope is collimated. As the last step, make sure all the locking screws are firmly, but not overly, tightened.

If an assistant is available, you may simplify the process by having your assistant adjust the screws while you keep your eye on the image. Moreover, to remove the guesswork from determining which of the three collimation sets need adjustment, have your assistant hold a pencil across the front of the telescope extending from the center to the outer edge like a spoke on a bicycle wheel. (Be careful not to touch the objective lens.) When you look at the defocused star, you will see the shadow of the pencil as a dark line extending from the center of the field of view to the edge. Have your assistant move the pencil around the front of the telescope (like the hand of a clock) until the shadow reaches the thickest or thinnest portion of the defocused star. At that time, the collimation set most in line with the pencil is where you should begin making adjustments.

Welcome to Our ED Triplet Essential Series

Designed to deliver crystal clear imagery rich in contrast, the premium telescopes in our ED Triplet Essential Series are the ideal optical instruments to capture the universe's breathtaking sights. Available in three apertures ranging from a grab-and-go 80mm to a versatile 127mm, these apochromatic refractors produce stunning views of countless celestial treasures like the Moon's chiseled craters, Saturn's elegant rings or the churning spiral of the face-on Pinwheel Galaxy. To provide you a true view of the cosmos, the telescopes in this series feature an air-spaced triplet optical design that virtually eliminates chromatic aberrations. In addition, they use a combination of genuine HOYA extra-low dispersion (ED) glass and proprietary EMD enhanced multi-layer coatings on all optical surfaces to generate brilliant high-contrast images with crisp definition. The quality of the optics also allows those seeking to push magnification based on their choices of eyepieces or focal extenders to do so without sacrificing clarity. To further guarantee precision performance, these telescopes include a three-point collimation cell that allows for pinpoint adjustments of the objective lens. Your ED Triplet Essential Series telescope offers all of these benefits and more. This set-up manual and the accompanying materials will guide you through a basic assembly process that will have you at the eyepiece and under the stars in no time.



Sun Warning

DO NOT USE this telescope or any accompanying finder scope to look at or near the Sun! Even momentary visual contact with the Sun's light rays can instantly cause irreversible damage to your eye(s). Eye damage can be painless, so there is no warning to the observer that damage has occurred until it is too late.

Take extra care when using the telescope or a finder scope during daylight hours, and do not point either at or near the Sun. Do not look through either when you are moving the instruments during the daytime. Never allow anyone to use the telescope or a finder scope during the daytime without warning them of the hazards of aiming either at or near the Sun. Make sure that they are adequately trained on the use of these instruments before allowing them to start observing. Children should always have informed and trained adult supervision while observing.

Proper Care Warning

Your telescope is a precision optical device and keeping the optics free of dust and dirt is crucial for optimal performance. However, the use of improper cleaning techniques, tools and/or solutions can cause irreparable damage to your telescope. In terms of solutions, use distilled water and/or an optical glass cleaner that can be found at most camera stores. Only use pure cotton swabs/balls or white, unscented, lotion-free tissues for wiping down optics after you have removed as many particles as possible with forced air or a photographic-grade camel hair brush. **DO NOT** use optical lens cleaning tissues as many contain fiberglass particles that can be abrasive.

Unpacking and Moving

Please Note: We recommend that you keep the original shipping box and packing materials if possible, in case your scope should ever need to be returned for service or warranty purposes. When the box is opened for the first time, you will find that all parts are packaged in plastic bags and the telescope's tube is wrapped in tissue. To begin assembly, slowly remove the optical tube. The 102mm, 127mm, and 152mm models will come with their cradle rings attached, which makes for easy removal. Rarely, the cradle could have come open during packing or shipping, so it is important to check the latches and then do a quick, small lift by the cradle handle to make sure the ring is secure before pulling the instrument all the way out. Although our telescopes are designed with portability in mind, it is important to use proper lifting techniques to prevent back injury and/or strained muscles. Whenever possible, use two people to move or lift the equipment and make use of wheeled devices like carts or dollies for additional aid. Due to its necessary size and weight, the 152mm model's case comes with wheels for easier transport.

Dew Shield

The dew shield is an important part of your telescope because it slows moisture build-up on the objective lens and can reduce image interference caused by ambient light. We advise using the dew shield when possible to maximize these crucial benefits. For the 80mm, 102mm and 127mm models, the dew shield is an easy-to-operate retractable style that slides smoothly up and down the optical tube assembly with no installation required.

Diagonal

Astronomical observation usually requires the telescope to tilt up significantly, which can make straight-thru viewing awkward and uncomfortable. A diagonal solves this comfort problem by using a mirror to direct the light at a 90° angle toward the eyepiece, which is positioned perpendicular to the OTA making the image more accessible. Equipped to fit both 1.25" and 2" eyepieces, your telescope's diagonal houses a precision-polished, two-inch mirror that is 99% reflective to maximize light transmission. To install the diagonal, begin by removing the dust covers from the focuser's drawtube and the diagonal itself. Loosen the screws on the drawtube's tension collar, and slide the barrel of the diagonal into the drawtube. Tighten the three tension screws to secure it firmly. Should one of these tension screws accidentally become loose, the barrel of the diagonal is tapered to prevent it from falling out of the focuser. The 1.25" eyepiece adapter or 2" eyepieces can be secured in the diagonal by tightening the tension screws on the compression ring lock. The 1.25" adapter also has a compression ring to secure eyepieces that are inserted into it. Please note: Your telescope may come with extension tubes for situations in which you need more back focus. Please see the "Focusers" insert for more information on how to install these accessories between the focuser and the diagonal.

Cradle Rings

(The following section does not apply to the 80mm model, as it does not include or need a cradle ring. Instead, the 80mm has a vixen dovetail plate attached directly to the OTA.) To attach the 102mm or 127mm model to a mount you will need to use the individual model's included cradle ring set.

Engineered to snugly grip its particular telescope, each extruded aluminum cradle assembly includes a hinged ring system, a slotted carry handle and a felt-lined interior that protects the tube's delicate surface. The rings are attached to a saddle plate to secure your scope to a mount. The cradles for the 102mm and 127 models have vixen dovetail plates. To attach cradle rings to your OTA, release the locking mechanism on each ring. On the 102mm model, the locking mechanism consists of a metal bar capped with oversized thumbscrews. At the point where each half of the ring meets, simply flip the bar over and tighten the thumbscrews. The 127mm model has an easy-to-operate latching lock mechanism. If you are only repositioning the tube, you probably will not need to remove the assembly completely. Instead, you can undo the lock on each ring so that the tube is loose enough in the rings to slide back and forth or rotate. Be careful to hold the tube securely so that you do not lose control of it while the cradle rings are loose. Once the tube is in the desired position, be sure to retighten each lock. Finding the right placement of the cradle ring assembly involves finding your individual scope's balance point, which depends largely on the accessories you will be using.

To begin assembly, slowly remove the optical tube from its foam casing. The 102mm and 127mm models will come with their cradle rings attached, which makes for easy removal. Rarely, the cradle could have come open during packing or shipping, so it is important to check the latches and then do a quick, small lift by the cradle handle to make sure the ring is secure before pulling the instrument all the way out. Although our telescopes are designed with portability in mind, it is important to use proper lifting techniques to prevent back injury and/or strained muscles. Whenever possible, use two people to move or lift the equipment and make use of wheeled devices like carts or dollies for additional aid.

Figure 1

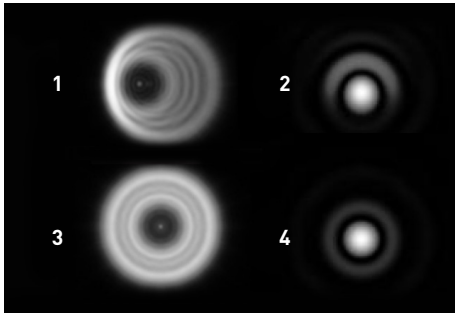

Defocused and focused out-of-collimation star images (1 and 2)

Defocused and focused properly collimated star images (3 and 4)

Collimation

Aligning the optics in your Explore Scientific Essential Series telescope (a process called “collimation”) is a technical process that was performed by trained personnel in our quality control department. With proper care (such as transporting your telescope in its original shock-resistance packaging) your telescope can provide years of enjoyment without additional adjustments. (Unlike REFLECTING style telescopes whose large, loosely-held mirrors need frequent adjustments, your REFRACTING style telescope contains a cell of lenses that is firmly locked in position.) If, however, the optical alignment in your telescope should require adjustment, we do not require that you return your telescope to our technicians for service, but we do recommend that the process be performed by an experienced, knowledgeable person.

To check the alignment of the optics in your telescope, find a bright star with your lowest power eyepiece and center it in the field of view. Next, change to a high power eyepiece and defocus the image slightly until you see a ring pattern similar to #3 in Figure 1. Now bring the image to its sharpest focus. Doing so should reveal your target star as a bright tiny dot (called the Airy disk, named after George Biddell Airy) surrounded by one or more rings (called the Airy pattern) that look similar to #4 in Figure 1. If the images in your eyepiece reflect the same symmetry depicted in #3 and #4 in Figure 1, the optics in your telescope are properly aligned.

However, if the image in your eyepiece looks more like #1 or #2 in Figure 1, re-collimating your telescope is recommended. For this purpose, the objective lenses in your telescope are mounted in a cell that is equipped with a collimation system consisting of three pairs of screws. Each pair of screws is called a collimation set and consists of one adjusting screw and one locking screw. These screws are accessible at the front of your telescope around the edge of the objective lens cell. Within each collimation set, the locking screw is the one that protrudes farther out from the bracket around the lens cell. To turn these screws you will need a 3mm hex wrench.

To begin the collimation process, remove or retract the dew shield (depending on the model of your telescope) and take off the dust cover to access the screws in the collimation system. Using a low-power eyepiece, center a bright star in the field of view. Replace the low-power eyepiece with a high-power eyepiece and defocus the image until the star develops distinct rings. Be careful not to defocus the image so far that you lose sight of the rings. Your goal now is to make the defocused image appear symmetrical (as in #3 in Figure 1) by making adjustments in one or more of the collimation sets.

To make an adjustment, loosen the locking screw in one of the collimation sets and then turn the adjusting screw a quarter turn in or out. Gently re-secure the locking screw, being careful not to over-tighten. Recheck the image to see how it was affected by the adjustment you made. By repeating this process determine which adjustments make the defocused image more and more symmetrical. Once your image looks like #3 in Figure 1, your telescope is collimated. As the last step, make sure all the locking screws are firmly, but not overly, tightened.

If an assistant is available, you may simplify the process by having your assistant adjust the screws while you keep your eye on the image. Moreover, to remove the guesswork from determining which of the three collimation sets need adjustment, have your assistant hold a pencil across the front of the telescope extending from the center to the outer edge like a spoke on a bicycle wheel. (Be careful not to touch the objective lens.) When you look at the defocused star, you will see the shadow of the pencil as a dark line extending from the center of the field of view to the edge. Have your assistant move the pencil around the front of the telescope (like the hand of a clock) until the shadow reaches the thickest or thinnest portion of the defocused star. At that time, the collimation set most in line with the pencil is where you should begin making adjustments.

Welcome To Our ED Triplet Carbon Fiber Series

Designed to deliver crystal clear imagery rich in contrast, the premium telescopes in our ED Triplet Carbon Fiber Series are the ideal optical instruments to capture the universe's breathtaking sights. Available in four apertures ranging from a grab-and-go 80mm to a far-reaching 152mm, these apochromatic refractors produce stunning views of countless celestial treasures like the Moon's chiseled craters, Saturn's elegant rings or the churning spiral of the face-on Pinwheel Galaxy. To provide you a true view of the cosmos, the telescopes in this series feature an air-spaced triplet optical design that virtually eliminates chromatic aberrations. In addition, they use a combination of genuine HOYA extra-low dispersion (ED) glass and proprietary EMD enhanced multi-layer coatings on all optical surfaces to generate brilliant high-contrast images with crisp definition. The quality of the optics also allows those seeking to push magnification based on their choices of eyepieces or focal extenders to do so without sacrificing clarity. To further guarantee precision performance, these telescopes include a three-point collimation cell that allows for pinpoint adjustments of the objective lens and a carbon fiber optical tube assembly that eliminates focus change attributed to shrinking or expansion caused by temperature fluctuations. Your ED Triplet Carbon Fiber Series telescope offers all of these benefits and more. This set-up manual and the accompanying materials will guide you through a basic assembly process that will have you at the eyepiece and under the stars in no time.



Sun Warning

DO NOT USE this telescope or any accompanying finder scope to look at or near the Sun! Even momentary visual contact with the Sun's light rays can instantly cause irreversible damage to your eye(s). Eye damage can be painless, so there is no warning to the observer that damage has occurred until it is too late.

Take extra care when using the telescope or a finder scope during daylight hours, and do not point either at or near the Sun. Do not look through either when you are moving the instruments during the daytime. Never allow anyone to use the telescope or a finder scope during the daytime without warning them of the hazards of aiming either at or near the Sun. Make sure that they are adequately trained on the use of these instruments before allowing them to start observing. Children should always have informed and trained adult supervision while observing.

Proper Care Warning

Your telescope is a precision optical device and keeping the optics free of dust and dirt is crucial for optimal performance. However, the use of improper cleaning techniques, tools and/or solutions can cause irreparable damage to your telescope. In terms of solutions, use distilled water and/or pure isopropyl alcohol (99%). Do not eat, drink or smoke while using this substance, wear protective gloves and eyewear, use in a ventilated area and follow proper disposal techniques. Only use pure cotton swabs/balls or white, unscented, lotion-free tissues for wiping down optics after you have removed as many particles as possible with forced air or a photographic-grade camel hair brush. **DO NOT** use optical lens cleaning tissues as many contain fiberglass particles that can be abrasive.

Unpacking and Moving

Please Note: We recommend that you keep the original shipping box and packing materials if possible, in case your scope should ever need to be returned for service or warranty purposes. Each model in this series comes packed in a deluxe case with spring-loaded butterfly latches and handles on both ends. After twisting all four latches open, you will be able to fully remove the lid to reveal the molded interior that includes specific spaces for all included accessories. When the case is opened for the first time, you will find that all parts are packaged in plastic bags and the telescope's tube is wrapped in tissue. To begin assembly, slowly remove the optical tube from its foam casing. The 102mm, 127mm and 152mm models will all come with their cradle rings attached, which makes for easy removal. Rarely, the cradle could have come open during packing or shipping, so it is important to check the latches and then do a quick, small lift by the cradle handle to make sure the ring is secure before pulling the instrument all the way out. Although our telescopes are designed with portability in mind, it is important to use proper lifting techniques to prevent back injury and/or

strained muscles. Whenever possible, use two people to move or lift the equipment and make use of wheeled devices like carts or dollies for additional aid. Due to its necessary size and weight, the 152mm model's case comes with wheels for easier transport.

Dew Shield

The dew shield is an important part of your telescope because it slows moisture build-up on the objective lens and can reduce image interference caused by ambient light. We advise using the dew shield when possible to maximize these crucial benefits. For the 80mm, 102mm and 127mm models, the dew shield is an easy-to-operate retractable style that slides smoothly up and down the optical tube assembly with no installation required. On the 152mm model, the dew shield is stationary and must be attached using the included set screws. To do this, remove the optical tube assembly from its case, take off the front dust cover and gently slide off the dew shield, which is in a reverse position during storage. During packaging, a foam padding is placed between the tube and the dew shield. This can now be removed. Flip the dew shield around, reattach it to the front of the tube and secure it by carefully tightening the three set screws. During breakdown, simply reverse the process.

Diagonal

Astronomical observation usually requires the telescope to tilt up significantly, which can make straight-thru viewing awkward and uncomfortable. A diagonal solves this comfort problem by using a mirror to direct the light at a 90° angle toward the eyepiece, which is positioned perpendicular to the OTA making the image more accessible. Equipped to fit both 1.25" and 2" eyepieces, your telescope's diagonal houses a precision-polished, two-inch mirror that is 99% reflective to maximize light transmission. To install the diagonal, begin by removing the dust covers from the focuser's drawtube and the diagonal itself. Loosen the screws on the drawtube's tension collar, and slide the barrel of the diagonal into the drawtube. Tighten the three tension screws to secure it firmly. Should one of these tension screws accidentally become loose, the barrel of the diagonal is tapered to prevent it from falling out of the focuser. The 1.25" eyepiece adapter or 2" eyepieces can be secured in the diagonal by tightening the tension screws on the compression ring lock. The 1.25" adapter also has a compression ring to secure eyepieces that are inserted into it. Please note: Your telescope may come with extension tubes for situations in which you need more back focus. Please see the "Focusers" insert for more information on how to install these accessories between the focuser and the diagonal.

Cradle Rings

(The following section does not apply to the 80mm model, as it does not include or need a cradle ring. Instead, the 80mm has a vixen dovetail plate attached directly to the OTA.) To attach the 102mm, 127mm or 152mm model to a mount you will need to use the individual model's included cradle ring set.

Engineered to snugly grip its particular telescope, each extruded aluminum cradle assembly includes a hinged ring system, a slotted carry handle and a felt-lined interior that protects the tube's delicate surface. The rings are attached to a saddle plate to secure your scope to a mount. The cradles for the 102mm and 127 models have vixen dovetail plates, while the 152mm model has a Losmandy-style plate. To attach cradle rings to your OTA, release the locking mechanism on each ring. On the 102mm model, the locking mechanism consists of a metal bar capped with oversized thumbscrews. At the point where each half of the ring meets, simply flip the bar over and tighten the thumbscrews. The 127mm and 152mm models have an easy-to-operate latching lock mechanism. If you are only repositioning the tube, you probably will not need to remove the assembly completely. Instead, you can undo the lock on each ring so that the tube is loose enough in the rings to slide back and forth or rotate. Be careful to hold the tube securely so that you do not lose control of it while the cradle rings are loose. Once the tube is in the desired position, be sure to retighten each lock. Finding the right placement of the cradle ring assembly involves finding your individual scope's balance point, which depends largely on the accessories you will be using.

Before attempting to find this point, you should make sure the diagonal and/or any heavy attachments like cameras or large eyepieces are installed. On the models with vixen dovetail saddle plates attached to the

cradle rings, you may need to make adjustments for cone error if you are using a German equatorial mount. Cone error occurs when the polar axis of your mount and the center of your telescope's optical axis are not aiming at the same point in the sky. To check for cone error, you will need to first line your mount up with a fairly fixed point in the sky like Polaris or a stationary terrestrial target that will be far enough away to see well in your telescope. Mount your telescope and see if it is centered on the same target. If it is not, you will need to take the scope off of the mount and slightly tilt the telescope tube away from or toward the saddle plate by threading the adjusting screws in or out. These screws flank a central locking screw on each end of the saddle plate. The process will take some trial and error before the perfect adjustments are found. Please note that when the final adjustments are made, the center locking screw must have enough engagement with the threads of the cradle ring to make sure that the saddle plate stays connected.

Figure 1

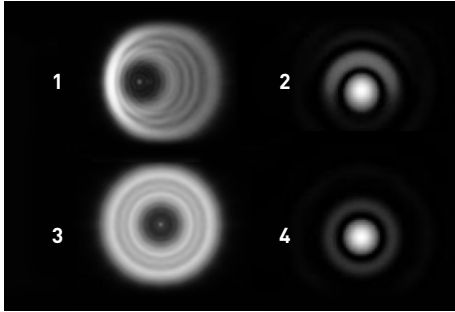

Defocused and focused out-of-collimation star images (1 and 2)

Defocused and focused properly collimated star images (3 and 4)

Collimation

Aligning the optics in your Explore Scientific Carbon Fiber APO Triplet Series telescope (a process called "collimation") is a technical process that was performed by trained personnel in our quality control department. With proper care (such as transporting your telescope in its original shock-resistance packaging) your telescope can provide years of enjoyment without additional adjustments. (Unlike REFLECTING style telescopes whose large, loosely-held mirrors need frequent adjustments, your REFRACTING style telescope contains a cell of lenses that is firmly locked in position.) If, however, the optical alignment in your telescope should require adjustment, we do not require that you return your telescope to our technicians for service, but we do recommend that the process be performed by an experienced, knowledgeable person.

To check the alignment of the optics in your telescope, find a bright star with your lowest power eyepiece and center it in the field of view. Next, change to a high power eyepiece and defocus the image slightly until you see a ring pattern similar to #3 in Figure 1. Now bring the image to its sharpest focus. Doing so should reveal your target star as a bright tiny dot (called the Airy disk, named after George Biddell Airy) surrounded by one or more rings (called the Airy pattern) that look similar to #4 in Figure 1. If the images in your eyepiece reflect the same symmetry depicted in #3 and #4 in Figure 1, the optics in your telescope are properly aligned.

However, if the image in your eyepiece looks more like #1 or #2 in Figure 1, re-collimating your telescope is recommended. For this purpose, the objective lenses in your telescope are mounted in a cell that is equipped with a collimation system consisting of three groups of screws. Each group of screws is called a collimation set and consists of one adjusting screw and one or two locking screws. (The 102mm and 127mm telescopes have one locking screw in each group. The 80mm and 152mm telescopes have two locking screws in each group.) These screws are accessible at the front of your telescope around the edge of the objective lens cell. The adjusting and locking screws can be distinguished by the fact that the locking screws protrude farther out from the bracket around the lens cell than the adjusting screws. To turn these screws on either an 80mm or a 102mm telescope you will need a 2.5mm hex wrench. In the case of a 127mm telescope, you will need a 3mm hex wrench. For a 152mm telescope, you will need a 4mm hex wrench.

To begin the collimation process, remove or retract the dew shield (depending on the model of your telescope) and take off the dust cover to access the screws in the collimation system. Using a low-power eyepiece, center a bright star in the field of view. Replace the low-power eyepiece with a high-power eyepiece and defocus the image until the star develops distinct rings. Be careful not to defocus the image so far that you lose sight of the rings. Your goal now is to make the defocused image appear symmetrical (as in #3 in Figure 1) by making adjustments in one or more of the collimation sets.

To make an adjustment, loosen the locking screw(s) in one of the collimation sets and then turn the adjusting screw a quarter turn in or out. Gently re-secure the locking screw(s), being careful not to over-tighten. Recheck the image to see how it was affected by the adjustment you made. By repeating this process determine which adjustments make the defocused image more and more symmetrical. Once your image looks like #3 in Figure 1, your telescope is collimated. As the last step, make sure all the locking screws are firmly, but not overly, tightened.

If an assistant is available, you may simplify the process by having your assistant adjust the screws while you keep your eye on the image. Moreover, to remove the guesswork from determining which of the three collimation sets need adjustment, have your assistant hold a pencil across the front of the telescope extending from the center to the outer edge like a spoke on a bicycle wheel. (Be careful not to touch the objective lens.) When you look at the defocused star, you will see the shadow of the pencil as a dark line extending from the center of the field of view to the edge. Have your assistant move the pencil around the front of the telescope (like the hand of a clock) until the shadow reaches the thickest or thinnest portion of the defocused star. At that time, the collimation set most in line with the pencil is where you should begin making adjustments.

Introduction To Our Eyepieces

Your telescope's eyepiece is more than a simple accessory. It sets the magnification and field of view of your optical system and is a critical component in determining how profoundly you connect with the cosmos. Designed to provide wide fields of view for a full immersion experience, Explore Scientific®'s premium eyepieces ensure stunning detail with high-end optics that allow your telescope to reach its full potential. We offer five series of eyepieces that differ in factors like field of view, available focal lengths, barrel diameter and eye relief. However, they all share characteristics that guarantee superior image quality. For peak performance, each of our precision eyepieces offers lenses made of low-dispersion glass with a high refractive index. In addition, each lens is fully multi-coated with durable enhanced multi-layer deposition (EMD) coatings. The combination of these factors brilliantly captures the celestial wonders you seek with sharp contrast, high resolution and crisp definition. To protect the precision optics, the body of each eyepiece is O-ring sealed and purged with an inert gas (either argon or nitrogen) for a waterproof environment that is impervious to internal fogging and prevents contaminants like fungus and dust from entering. Each also offers foldable soft silicone rubber eyecups to provide the most comfortable viewing experience and a filter thread on the backside that will allow for use of moon or light filters.

There are two distinct types of field of view to consider in any eyepiece. The first of these is Apparent Field of View (AFOV). Expressed in degrees, the AFOV is the perceived angle from your eye to the edges of the field stop of an eyepiece. The larger the AFOV, the more area you will see. With AFOVs ranging from a wide 62° to a hyper-wide 120°, our five lines of eyepieces will open

up vast expanses of inky black sky for you to explore. To provide views that are truly stunning, each eyepiece model is designed with the distinct number and configuration of elements (optical lenses) needed to ensure a well corrected field of view is maintained as the angle widens. The benefits of our wide field eyepieces go beyond the amount they reveal. When you have more sky to work with, objects are easier to locate and stay in the field of view longer, which translates to fewer adjustments. This is especially helpful when you are using a non-driven mount. These eyepieces also allow the viewer to use averted vision, which is a technique that aids in observing faint objects. When using averted vision you gaze slightly to the side of your target object rather than directly at it. This puts the image on a part of your eye that is more sensitive to light, which allows you to enjoy fainter objects. The second type of field of view is True Field of View (TFOV), which is the actual field of view of the sky or terrestrial scene expressed in degrees and/or fractions of a degree as seen through a telescope/eyepiece combination. To calculate the TFOV, you will divide the apparent field of view by the magnification.

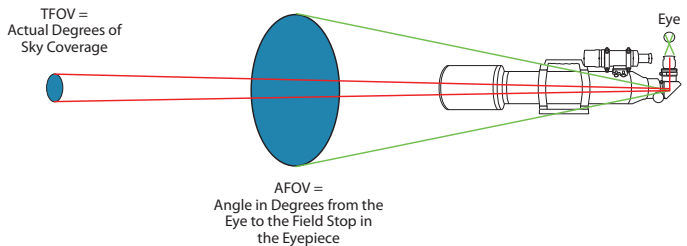

$$\text{True Field of View} = \frac{\text{Apparent Field of View}}{\text{Magnification}}$$

For example, if the resulting magnification from your telescope and eyepiece set-up is 50x and your eyepiece has a 100° AFOV, you will divide 100 by 50 to get a TFOV of 2°. TFOVs usually range between .25° to 2 degrees.

Magnification

One of the main roles the eyepiece plays is setting the magnification or power of a specific optical set-up. The amount of magnification you will want to use depends largely on your subject. To calculate magnification, divide the focal length of the telescope by the focal length of the chosen eyepiece. The resulting number will be your power.

$$\text{Magnification} = \frac{\text{Telescope Focal Length}}{\text{Eyepiece Focal Length}}$$

For example, a 20mm eyepiece in a telescope with a 1,000mm focal length will result in 50x power, which will make the object appear 50 times larger. If you change the eyepiece, the power goes up or down accordingly.

When choosing magnification, it is important to remember that the lower the power the brighter the image. If you are observing the Moon or a notable double star, a high power eyepiece will work well because the loss of brightness that occurs as magnification amps up is not a huge factor. However, if you are viewing a dim subject like an expansive galaxy or a faint nebula, you will want to use your lowest power because you will need all of the brightness you can get. Overall, the best way to determine what magnification level to use is to try different powers and see how the image changes. Having a nice range of eyepieces available can be the most rewarding way to enjoy all that the night sky has to offer.

Exit Pupil

The exit pupil is the diameter of the beam of light coming out of the eyepiece. To calculate exit pupil, divide the focal length of your eyepiece by your telescope's focal ratio. For example, if you use a 20mm eyepiece with an f/5 telescope, the exit pupil would be 4mm.

$$\text{Exit Pupil} = \frac{\text{Eyepiece Focal Length}}{\text{Telescope Focal Ratio}}$$

Eye Relief

Eye relief is all about a comfortable viewing experience because it is the distance at which you need to position your eye from the eyepiece's outermost surface to enjoy the full field of view. This characteristic is of special concern to observers who wear glasses to correct an astigmatism, because a long enough eye relief is necessary to allow room for glasses. A full spectrum of eye relief distances is represented across our five eyepiece lines.

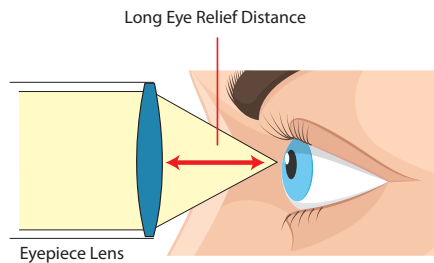
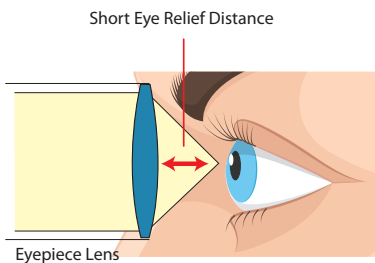

Other Accessories:

Focal Extenders

Available in 2x, 3x and 5x in a 1.25" barrel and 2" barrel, our focal extenders add versatility to your eyepiece line-up by allowing each eyepiece to perform at two powers. For example, if your particular eyepiece/telescope combination results in a 50x power, adding a 2x focal extender will change that to a 100x power. To guarantee superior image quality, our focal extenders use multiple lens elements that are made of high-quality glass and fully multi-coated with EMD coatings to reduce chromatic and spherical aberrations. To use a focal extender, install it in the eyepiece barrel of your telescope/diagonal before the eyepiece and then secure the eyepiece into it.



FE02-125
2x Focal Extender;
1.25-inch O.D. Barrel



FE02-020
2x Focal Extender;
2-inch O.D. Barrel



FE03-125
3x Focal Extender;
1.25-inch O.D. Barrel



FE05-125
5x Focal Extender;
1.25-inch O.D. Barrel

Coma Corrector

Coma is a common optical aberration that can plague the outskirts of your image. When coma is present, stars in the center of the field will pop like precise points of light, but stars at the edge take on an unnatural comet-like shape. Explore Scientific®'s Coma Corrector can help you minimize or even eliminate image aberrations caused by this off-axis optical phenomenon even in fast Newtonians.

Our 2" coma corrector offers multi-coated lenses, a black-anodized aluminum barrel with spacer markings and a textured rubber grip. Tightly secured by three thumbscrews, this accessory comes with two adapters (.75" and 1") to secure to your T adapter and a protective cap.



HRCC02-00
2" HR Coma Corrector
for Newtonians

Field Flattener

A curved focal plane is an inherent feature in most telescope designs and is nothing to note for general stargazers. But, for astrophotographers, the consequences of that same curved plane can ruin hours of patient imaging. Designed for refracting telescopes, Explore Scientific®'s Field Flattener can tackle the edge-of-field aberrations caused by this necessary curvature to ensure your long night at the eyepiece will not be in vain. This accessory offers fully multi-coated optics and slides securely into the 2" eyepiece holder.



FFEDAPO-00
2" Field Flattener Lens
for ED APOs

Focal Reducer

Explore Scientific®'s 3" Field Flattener/.7x Focal Reducer is a multi-faceted accessory designed to enhance your astrophotography experiences. As a field flattener, this piece addresses the edge-of-field aberrations caused by curved focal planes to ensure your night at the eyepiece will result in crisp, true images. As a focal reducer, this device will reduce your f-ratio by .7, which results in a wider field of view, brighter images and less exposure time. Recommended for our 127mm and 152mm refracting telescopes, this accessory is designed for f/7.5 to f/8.5 ratios and is best centered on an f/8 optical design. This field flattener/focal reducer boasts fully multi-coated optics and comes with a 2" adapter to accommodate different focuser sizes and two T-thread adapters.



FFFR507X-00
3" Field Flattener .7x
Focal Reducer for ED
APO 152mm F/8

Cleaning Eyepieces

The subject of cleaning telescope eyepieces is shrouded in misconceptions. One is the belief that any trace of contaminant on an eyepiece will degrade its performance when, actually, a somewhat dirty eyepiece often performs as well as a perfectly clean one. Thus, many eyepiece owners clean eyepieces that do not need to be cleaned. Since any contact with an optical surface subjects the surface to potential damage, this unnecessary cleaning merely increases the possibility of harm. The owner of an eyepiece would do well to adhere to the adage: If it ain't broke, don't fix it. An eyepiece needs to be cleaned when the image seen through the eyepiece is degraded (such as a hazy and/or reduced-contrast image)—not when a minor blemish is observed on the glass.

Another misconception originated in the days when the coatings on eyepiece optics were soft and easily subject to scratches or other damage.* Coatings today are far more resilient, and therefore the chance of damaging a modern eyepiece during cleaning is greatly reduced. By observing reasonable care, one can restore a dirty eyepiece to pristine condition without undue fear of damage. In turn, the process of cleaning eyepieces is much less technical or mysterious than many believe. Most camera supply stores provide lens cleaning kits whose materials and directions suffice for astronomical eyepieces. This, in fact, is an option we recommend.

However, you do not need to buy a commercial cleaning kit to clean your Explore Scientific eyepieces. Most of the materials required are probably already in your home. Here is a short list of items we recommend.

1. "Cleaning wands" made by breaking/tearing a tightly-rolled soft-fiber, lotion-free, non-scented tissue in half. This produces "wands" (or "brushes") whose ragged ends produced by breaking the roll serve as soft, absorbent brushes. (We hesitate to make particular tissue recommendations because companies may alter their product after this article is circulated. Thus, with reservations, we suggest Kleenex Softique or similar.)
2. A soft photographic-grade camel-hair brush. Actually, many soft makeup brushes suffice.
3. A spray bottle containing distilled water.
4. A spray bottle containing either isopropyl alcohol (90% or better) or a cleaning solution consisting of 1/3 cup isopropyl alcohol, 2/3 cup distilled water, and two drops of pure, clear, non-perfumed, liquid dishwashing detergent. (Again, we hesitate to recommend a particular product. Consider such brands as Dawn and Palmolive.)
5. A blower bulb (a rubber bulb that can be used as a bellows). A compressed air canister will also suffice, however these canisters can "spit" foreign substances, especially if shaken or turned upside down. Thus, careless use of a compressed air canister may extend the cleaning process rather than assist it.
6. A clean micro-fiber cloth.
7. A Soft clean absorbent cotton cloth.

Finally, before proceeding, an important disclaimer is in order. We are discussing techniques for cleaning Explore Scientific eyepieces. These eyepieces are sealed and thus waterproof. Moisture and other pollutants cannot enter an Explore Scientific eyepiece during the cleaning process. You can completely submerge an Explore Scientific eyepiece in water without harming the eyepiece.**

This is not the case with other eyepieces. If you apply the following process to other eyepieces, you should alter the steps to avoid contaminating the interior of those eyepieces.

Now let's look at the actual cleaning procedure, which we approach as a two-step process. The first is to remove all the foreign substances that have collected on the eyepiece; the second is to terminate the cleaning procedure in a way that does not leave cleaning residue on the eyepiece. We will take these steps in order.

Step 1. Removal of Foreign Substances:

Removing foreign substances from an eyepiece requires techniques that depend on the substance. In the case of only a few visible particles of dust, cleaning is probably not necessary. However, if you wish, you can remove the particles by blowing with a blower bulb or gently lifting the particles off the glass with a soft photographic-grade camel-hair brush. If this is all that is needed, we recommend that you terminate the cleaning process here. However, if some dust remains you may wish to remove the rubber eye guard, rinse the optical surface under warm running water, and continue the cleaning procedure with Step 2.

More serious cases involve foreign materials that tend to stick to the eyepiece glass (e.g. finger prints, makeup, dew spots, pollen, etc.). In these cases we recommend beginning with the process just described (that is: remove any large, visible particles with blower bulb or a soft camel-hair brush, then take off the rubber eye guard and rinse the optical surface with warm running water). After this initial cleaning, spray the eyepiece optics with either 90% or better isopropyl alcohol or the cleaning solution described above. Then, gently swab the moistened optics with a clean micro-fiber cloth or the ragged ends of cleaning wands (produced as described above). Finally, rinse the eyepiece optics under warm running water before moving on to Step 2.

Step 2. Avoidance of Cleaning Residue:

The second step in the cleaning procedure is to produce a dry eyepiece without those dreaded “water spots.” This can be accomplished by “rinsing” the cleaned optics with distilled water and then either blowing or blotting (not whipping) the surface dry. Here, “rinsing” can be performed in many ways. You could completely submerge an Explore Scientific eyepiece in a bath of distilled water, although that would require more water than is necessary. A more conservative approach is merely to spray the optics with distilled water via a spray bottle. Regardless of the rinsing technique you select, complete the process by drying the eyepiece optics with a blower bulb or by gently blotting (not whipping) with a soft clean absorbent cotton cloth.

*These coatings improve the optical characteristics of the lens’ surfaces so that a lower percentage of light is randomly deflected and scattered within the eyepiece. The result is a brighter, higher-contrast image.

** We cannot resist including a particular customer feedback that we recently received. The owner of several Explore Scientific eyepieces tells us that he returned home from a star party with exceptionally dirty eyepieces. He removed the rubber eye guards and washed the eyepieces in his dish washer (with heat turned off). The result was a set of pristine eyepieces. We do **NOT** recommend this procedure, but we’re proud that our nitrogen/argon purged waterproof eyepieces passed this test with flying colors.

Introduction To Our Finderscopes

Finding a specific target in the vastness of the night sky can be a daunting and frustrating task when the only tool at your disposal is a telescope. To help you hone in on the celestial wonder you seek, a good finderscope that is properly aligned is a necessity. Our eight-power 50mm finderscopes are designed to be precision optical instruments in their own right. Outfitted with a fully multi-coated doublet main lens and a long eye-relief eyepiece with a precision crosshair or reticle (depending on the model), our finderscopes provide high resolution, high contrast images at low magnification to effortlessly and quickly orient your telescope to a particular object or area of the sky. Although they share a common mission to provide easy guidance, we do offer three distinct models. They are: **Non-Illuminated Straight Finderscope:** This classic reverse-view finderscope has a simple crosshair that can be centered on your target. It features a front focus with locking ring and a bright 6° field of view. **Illuminated Straight Finderscope:** Explore Scientific®'s original straight-style, correct-image finderscope has a precision-etched illuminated open circle, crosshair reticle with adjustable deep red LED illumination that makes target acquisition easy. Precise focus of both the main objective lens and the eyepiece allow for the sharpest views of the target being viewed as well as the reticle. The finderscope's correct-image, right-side-up viewing produces a natural view that benefits astronomical and terrestrial observers. **Polar Illuminated Right-Angle Finderscope:** In addition to offering a right angle eyepiece for comfortable viewing and a larger 7° field of view, our top model comes with an illuminated reticle that features northern and southern polar reference markings for quick and precise polar alignments with any equatorial mount. Although it has a larger 7° field of view, it shares the same attention to design and features of the Illuminated Straight Finderscope. These include adjustable brightness for the reticle's deep red illumination, precision focus of both the main objective lens and the eyepiece and correct-image, right-side-up viewing.



Sun Warning

DO NOT USE a telescope or finderscope to look at or near the Sun! Even momentary visual contact with the Sun's light rays can instantly cause irreversible damage to your eye(s). Eye damage can be painless, so there is no warning to the observer that damage has occurred until it is too late. Take extra care when using a telescope or a finderscope during daylight hours, and do not point either at or near the Sun. Do not look through either when you are moving the instruments during the daytime. Never allow anyone to use a telescope or a finderscope during the daytime without warning them of the hazards of aiming either at or near the Sun. Make sure that they are adequately trained on the use of these instruments before allowing them to start observing. Children should always have informed and trained adult supervision while observing.

Proper Care Warning

Your finderscope is a precision optical device and keeping the optics free of dust and dirt is crucial for optimal performance. However, the use of improper cleaning techniques, tools and/or solutions can cause irreparable damage to your scope. In terms of solutions, use distilled water and/or an optical glass cleaner that can be found at most camera stores. Only use pure cotton swabs/balls or white, unscented, lotion-free tissues for wiping down optics after you have removed as many particles as possible with forced air or a photographic-grade camel hair brush. **DO NOT** use optical lens cleaning tissues as many contain fiberglass particles that can be abrasive.

Focusing Your Finderscope

Please note: This section does not apply to our Non-Illuminated Straight Finderscope, which does not have a focus feature. Our illuminated finderscopes allow for focus adjustments of both the objective lens and the eyepiece.

On the Illuminated Straight Finderscope, your initial focus adjustments can be made before you mount the finderscope to your telescope. While holding the finderscope in your hand, loosen the focus lock ring on the eyepiece by holding onto it while you turn the eyepiece focus adjuster counterclockwise. Once the adjuster is moving freely, let go of the lock ring and aim the finderscope at a blank wall. Turn the focus adjuster left or

right until you see the finderscope crosshairs reach perfect sharpness. Tighten the lock ring down to hold the focus position.

Now, loosen the objective lens focus adjuster in the same way. Aim the finderscope at a very distant, stationary object. Turn the objective lens focuser left or right until you see the object and the crosshairs reach perfect sharpness. Tighten the lock ring down to hold the focus position.

Once your finderscope is mounted on your telescope, repeat the process on the Moon or a bright star and make adjustments as necessary.

Mounting Your Finderscope

The first step in mounting your finderscope to your telescope is to slide it into the finderscope bracket, which has two rings to hold your finderscope in place. Each of these rings has three adjusting screws.

If your finderscope is not already installed in the bracket, loosen each of the adjusting screws until you have opened up the full inside diameter of the rings. Slide the finderscope into place and gently tighten all of the adjusting screws until your finderscope is secure.

The bracket has a dovetail base that slides easily into the mounting assembly that is already attached to the optical tube assembly (OTA). Once it is installed in the base, secure it by tightening the two large, heavy-duty plastic screws.

Please note: On our 102mm AR Doublet Achromatic Refractor, you will need to install the finderscope before you put on the cradle ring assembly. On all of our other telescope models, the finderscope can be installed after the cradle rings are in position.

Aligning Your Finderscope

Once your finderscope is mounted on your telescope, it is time to align the finderscope so that it and the telescope will be centered on the same spot in the sky when it is time to use it. Although the process can be tedious, it is important to follow through to avoid later frustrations that can ruin an observing session.

We recommend doing that first alignment in the daytime using a land-based target. Be careful to do this in an area where you will not accidentally point either your telescope or finderscope at or near the Sun, (see Sun Warning in this manual).

After you have set up your telescope and attached the finderscope, find an easy, stationary target that is at least 200 meters away. We suggest using a streetlight or the top of a telephone pole.

Insert your lowest power eyepiece into your telescope's eyepiece holder and center the chosen target in the telescope's eyepiece. Look through the finderscope's eyepiece and loosen or tighten one or more of the adjusting screws that are located on the finderscope rings until the crosshairs are precisely centered on the same target as the telescope.

Once you have reached the most accurate position, repeat the process with a medium and a high power eyepiece in your telescope if possible. Once night falls, center the Moon or a bright star in your finderscope then check the view in your scope. Make small adjustments as needed.

Using Your Illuminator

Please note: This section does not apply to our Non-Illuminated Straight Finderscope. To turn your illuminator on, simply turn the top dial past the click stop. If you continue to turn it clockwise, the illuminator will get brighter, but we recommend that you use it at the dimmest setting that will still allow you to comfortably see the red-illuminated crosshairs or polar reference markings (depending on which model you are using).

Changing Batteries On Your Illuminator

The batteries that power your finderscope's illuminator should last for several hours of continuous illumination, but we do recommend turning the illuminator off when not in use to preserve battery life.

To change the batteries on your illuminator, unthread the illuminator from the finderscope by grasping the entire unit and twisting it counterclockwise until it is free. Separate the two halves of the illuminator by holding the two ends and twisting counterclockwise. When the two halves are free of each other, carefully separate them so that the batteries and the sleeve that holds them do not pop out uncontrollably.

Replace the old batteries with two new LR41 batteries and reinstall the sleeve, making sure that the negative ends of the batteries are facing the LED illuminator.

Twist the halves back together and switch the illuminator on to make sure the batteries are working. If the illuminator works, rethread it onto the finderscope. If not, check that the polarity position is correct and that the batteries are new and fully charged. If the illuminator still does not come on, clean the battery terminals with a pencil eraser and try again. If the illuminator still does not respond, please contact our Customer Service Center at **(866) 252-3811** or online at **www.explorescientificusa.com**.

Introduction To Our Focusers

It takes more than excellent optics for your telescope to truly perform. If you want to capture the intricacies of our Moon's winding Hadley Rille or the spiraling arms of the Pinwheel Galaxy, you will need to have a superior focuser in your astronomical arsenal. The focuser is one of the most important mechanical components of your telescope because it is the tool you use to find and hold that perfect crisp image. Although there are differences in design, all four of our dual-speed focusers are built to meet high standards of precision and functionality. We want to make sure you see the details you seek without needing to make constant adjustments.

Common Features

In addition to a shared mission to provide you the best viewing experience, each of our focusers have some similar elements. These include:

- **Fine and Coarse Focusing:** On one side of each focuser you will find a stacked set of dials. The largest of the pair controls your coarse focusing and the smaller provides micro-focusing. Both controls are knurled so that you can grip them easily for smooth adjustments even when you are wearing gloves.
- **Locking and Tension Screws:** Although they are located in different places on each model, locking and tension screws perform vital functions on all of our focusers. To avoid unintended adjustments, the locking screw can be gently tightened to keep the focuser stationary once you have reached your desired focus. The tension screw(s) are used to put pressure on the drawtube to secure it and keep it from sliding when heavier accessories like cameras or large eyepieces are added.
- **Tension Collar:** At the end of each focuser, you will find a tension collar with three set screws that are used to hold a diagonal or an eyepiece in place.
- **Compression Ring Eyepiece Adapter:** The purpose of this component is to allow you to still use eyepieces/diagonals that are smaller than the diameter of the drawtube. Our three 2" focusers include a 1.25" adapter, while our Feather Touch 3" focuser includes a 2" adapter. The adapter locks into place in the tension collar by tightening the collar's set screws.

Styles of Focusers

Rack and Pinion Focuser

This focuser uses a circular gear (pinion) linked to the focus dials to move the drawtube along a linear rack lined with teeth. As you turn the dial the gear engages with the teeth guiding the drawtube in and out. On this 2" focuser, the locking screw is in the center on the underside of the focuser and the two tension screws that press down to keep the drawtube from slipping are on the top. This focuser is also rotatable, meaning that it can be easily repositioned to change the position of the dials or to meet your specific comfort or viewing needs. To use this feature, slightly loosen the tension screw on top of the visual back adapter on your telescope tube that presses down on the focuser, rotate the focuser and gently retighten the screw.





Crayford-Style Non-Rotatable Focuser

This focuser has a flat plane on the bottom side of the drawtube that rides along a roller assisted by ball bearings to smoothly adjust the focus. On this 2" focuser, the tension and locking screws are both located on the bottom of the focuser, with the smaller of the two serving as the locking mechanism that holds the focus dials stationary.

Crayford-Style Rotatable Focuser

This focuser has a flat plate installed on the bottom side of the drawtube that rides along a roller assisted by ball bearings to smoothly adjust the focus. On this 2" focuser, the tension and locking screws are both located on the bottom of the focuser, with the center most



of the two serving as the locking mechanism that holds the focus dials stationary. This focuser is also rotatable, meaning that it can be easily repositioned to change the position of the dials or to meet your specific comfort or viewing needs. To use this feature, slightly loosen the tension screw on top of the visual back adapter on your telescope tube that presses down on the focuser, rotate the focuser and gently retighten the screw.



Feather Touch 3" Focuser

This special edition 3" Feather Touch focuser made by Starlight Instruments is designed for use on our 152mm ED Triplet Carbon Fiber Telescope. It is an extremely high-quality rack and pinion focuser. On the Feather Touch, the tension screw is located on the top of the focuser, and the locking screw is on the bottom. This focuser is also rotatable, meaning that it can be easily repositioned to change the position of the dials or to meet your specific comfort or viewing needs. To use this feature, slightly loosen the three tension screws on the visual back adapter on your telescope tube that press down on the focuser. Rotate the focuser and gently retighten the screws.

Installing Your Focuser

The following is the procedure you should follow to install your focuser if it was not already on the telescope tube when you receive it or if you are changing focusers. One end of the focuser has the tension collar that secures a diagonal or eyepiece to the focuser. The other has a "lipped" end that fits directly into the visual back adapter on your telescope tube. Once the focuser housing is inserted into the visual back adapter, gently tighten down the set screws at the juncture to secure the focuser in place.

Advanced Tension Adjusting Technique for Crayford-Style Focusers

Most tension adjustments on our Crayford-style focusers can be easily accomplished by using the tension screw on the bottom of each model. However, if you feel more tension is needed, there are sets of small screws on the top of each device that can be used to adjust the pressure that is coming down on the drawtube from above. To make these adjustments, you will first need to loosen the button head screws (which are the largest in the sets) using a hex wrench. For these screws, which serve as locking screws, you will need a 2mm hex wrench for the Non-Rotatable Crayford-Style and a 2.5mm for the Rotatable Crayford-Style. Once the button heads are loose, you can begin by carefully tightening the four smaller screws equally using a 2mm hex wrench. It is important to make sure each of the four screws is tightened the same amount to avoid giving the drawtube an awkward and unbalanced tilt. Also be sure to make these adjustments in very small increments. If you make these screws too tight, the drawtube will not glide smoothly. If you make them too loose the drawtube will have difficulty maintaining its position. Once you are done adjusting the smaller screws, retighten the larger locking screws.

Extension Tubes

Some observing situations and accessories require more back focus than your focuser alone may be able to provide. Extension tubes aid in fixing this problem by extending the length of the drawtube. To install extension tubes, unthread the tension collar at the end of the focuser, thread the extension tube right onto the focuser tube and then rethread the tension collar onto the end of the extension tube. Depending on your needs you may want to use more than one extension tube. If that is the case, simply thread one tube onto the other before replacing the tension collar. You can then install your diagonal or eyepiece.

The Twilight Series Mounts

It takes more than high-end optics to truly connect with the universe. Our versatile and durable Twilight Series mounts are designed to give your telescopes the stable foundations they need to gracefully navigate the sky. The Twilight I and Twilight II are both alt-azimuth mounts that can smoothly move your telescope up, down and side-to-side and then firmly lock it into position to avoid frustrating slippage.

Perfect for small to mid-size telescopes, the Twilight I will support up to 18 pounds and features slow-motion controls on both axes that facilitate fine adjustments and easy object tracking. It also has an adjustable fork arm that will allow you to angle the head mount enough for some telescopes to point at the zenith.

Ideally suited for star parties and outreach, the Twilight II mount can accommodate two telescopes at once and hold up to 60 pounds. The movement of the heavy-duty mount is controlled by large chrome dials that are simple to manipulate even when you have on gloves. It also comes with an 8-inch pier extension to accommodate larger telescopes and provide a more comfortable viewing experience.

Both the Twilight I and II mounts come with chrome-plated steel tripods that offer a wide footprint and adjustable leg heights. To minimize vibrations, the legs are locked in place by a stabilizing plate that doubles as a convenient accessory tray. This set-up manual with guide you through the basic assembly process for both Twilight mounts so that you can be out in the field and under the stars in no time.

Parts

Please Note: We recommend that you keep the original shipping box and packing materials if possible, in case your mount should ever need to be returned for service or warranty purposes.

Before beginning the assembly process, we recommend taking an inventory of all parts. For both mounts, the original shipping container will have three boxes inside. The smallest of these is an empty spacer, and the largest holds the tripod assembly, which includes a stabilizing plate/accessory tray.

On the Twilight I, the mid-size box contains the head mount, a center support shaft, two slow-motion controls, two locking pins, a cup washer, an e-clip, two standard washers, and a 4.5mm hex wrench.

On the Twilight II, the mid-size box contains the head mount and its base, a pier extension assembly, a center support shaft, a cup washer, an e-clip and two standard washers. Although our mounts are designed with portability in mind, it is important to use proper lifting techniques to prevent back injury and/or strained muscles.

Twilight I Assembly and Use

To begin assembly, take the tripod out of its box and remove the plastic wrap. Spread the legs fully apart and make sure the two tension screws on each leg are tight. Once you have finished assembling the mount, you can adjust the tripod height by loosening these tension screws, extending each leg equally and retightening the screws.

Installing the Support Shaft

Take the center support shaft, which has a large T-bar on its bottom end, and put the two standard washers on it, if needed. Slide the stabilizing plate/accessory tray from the tripod box onto the support shaft with the flat side up. Thread the cup washer into its position near the top of the support shaft.

From the underside of the top of the tripod, insert the support assembly into the opening and push the e-clip on from above. The support assembly should now hang freely from the tripod top.

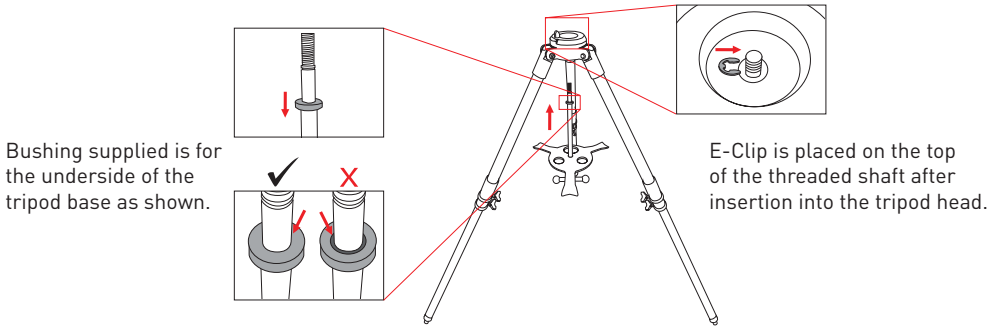

Bushing supplied is for the underside of the tripod base as shown.

E-Clip is placed on the top of the threaded shaft after insertion into the tripod head.

Installing the Head Mount

Remove the head mount from its box and take off the bubble wrap and plastic. Align the notch in the head mount with the post on the tripod housing. From below, turn the T-bar to thread the support assembly up into the head mount.

Once the mount is attached, position the plate/accessory tray so that its arms press firmly against the tripod's legs. Tighten the knurled nut between the T-bar and the washers, if needed, to secure the plate in place and further stabilize the tripod.

Installing the Slow-Motion Controls

Now that the head mount is in place, it is time to install the slow-motion controls to the brass pins on the head mount. The long one goes on the top pin and controls the vertical (altitude) movement of the telescope. The short one goes on the pin located at the base of the head mount and is used for horizontal (azimuth) motion. Finally, thread a locking pin into the holes near each installed control. These are used to lock the mount in place once you have achieved your desired position.

Adjusting the Angle of the Mount

When you take the head mount out of the box, its fork arm will be in the standard vertical position, which is great for daytime terrestrial viewing and many astronomical observing situations. However, the mount can be easily moved to a 60° angle to view steeper expanses of space and even point some telescopes to the zenith.

To change the angle of the head mount, remove the two socket head screws that hold the fork arm in place with the provided 4.5mm hex wrench. These screws are located on the side of the fork arm near its base. Once the screws are removed, rotate the fork arm downward toward the lower slow-motion control. Align the set of threaded holes that are closest to your desired angle then reinstall the two screws.

If changing the angle causes your telescope's optical tube assembly (OTA) to run into the azimuth slow-motion control, you can reposition the base of the fork arm. To do this, remove the four socket head screws that hold the base in place using the provided hex wrench. These will be located on the topside of the base. Rotate the fork arm away from the slow-motion control. Match the four threaded holes then reattach the screws.

Attaching a Telescope to the Mount

To attach your telescope to the mount, loosen the two tension screws (one has a large knurled head) on the top of the mount until the ends of the screws are flush with the interior wall of the dovetail holder. Slide the dovetail plate that is connected to your telescope into position and firmly retighten the screws.

Twilight II Assembly and Use

To begin assembly, take the tripod out of its box and remove the plastic wrap. Spread the legs fully apart and make sure the two tension screws on each leg are tight. Once you have finished assembling the mount, you can adjust the tripod height by loosening these tension screws, extending each leg equally and retightening the screws.

Installing the Support Shaft

Take the center support shaft, which has a large T-bar on its bottom end, and put the two standard washers on it. Slide the stabilizing plate/accessory tray from the tripod box onto the support shaft with the flat side up. Thread the cup washer into its position near the top of the support shaft.

From the underside of the top of the tripod, insert the support assembly into the opening and push the e-clip on from above. The support assembly should now hang freely from the tripod top.

Installing the Pier Extension/Head Mount

The Twilight II includes an 8-inch pier extension that is used to raise the height of the mount to accommodate larger telescopes and provide a more comfortable viewing experience. The pier extension comes in two parts.



TPE001-00
Twilight II Pier Extension
(Optional Accessory)

To begin, take the large cylinder and remove the three screws from the bottom using a 4mm hex wrench. Take the base piece of the head mount, insert it into the bottom of the pier, align the holes and rethread the three screws so that the pieces are securely joined.

Take the top piece of the pier extension and twist the threaded end into place atop the cylinder. Tighten the three screws around the edge with a 2mm hex wrench until secure. Take the completed pier assembly and align the notch in the bottom with the post on the tripod housing. From below, turn the T-bar to thread the support assembly up into the head mount base. Now, remove the head mount from the box and slide it onto the secured neck of the pier extension. If you choose not to use the pier extension, slide the head mount directly onto the installed base piece. Once the mount is attached, position the plate/accessory tray so that its arms press firmly against the tripod's legs. Tighten the knurled nut between the T-bar and the washers to secure the plate in place and further stabilize the tripod.

Attaching a Telescope to the Mount

To attach a telescope to the mount, loosen the two tension screws (one has a large knurled head) on the top of one side of the mount until the ends of the screws are flush with the interior wall of the dovetail holder. Slide the dovetail plate that is connected to your telescope into position and firmly retighten the screws. A second telescope can be mounted on the other side using the same process.

Moving the Mount

The head mount has two large dials that control the vertical (altitude) and horizontal (azimuth) movement of any mounted telescopes. To move the telescope(s) up and down, loosen the dial on the top, find your desired position and retighten the dial. To move the telescope(s) side to side, loosen the dial on the side, find your desired position and retighten the dial.

Normally, both sides of the head mount share the same angle. However, if you would like to change the angle on one without affecting the other, use a 3mm hex wrench to loosen (not remove) the screws on one arm. Gently rotate the arm to your desired angle, and retighten the screws.

Share the Sky!

Awakening individuals to the marvels of the universe can be one of the most rewarding aspects of owning a telescope.

When you share your eyepiece with others, you can witness their sense of wonder bloom as they take in celestial spectacles like the chiseled lunar terrain, the elegant rings of Saturn or the blue-white stars of the misty Orion Nebula for the first time.

Whether you are in your backyard, on a street corner or at star party, by using your telescope for outreach you are continuing a tradition started by Galileo more than 400 years ago. Since then, humanity's understanding of the universe has grown at an astounding pace, and much of that discovery can be linked to the desire to explore that is born from looking through a telescope.

Founded in 2000, the Astronomy Outreach network (AOn) was created to encourage and celebrate public outreach efforts by astronomers of all levels. This non-profit organization has tasked itself with forging connections between individual astronomers, astronomy clubs and larger astronomy and space education initiatives. No matter where you are at in your journey to provide outreach, AOn is a great resource that can be accessed at www.astronomyoutreach.net or through Facebook and Twitter.

As Carl Sagan said, "The Earth is a very small stage in a vast cosmic arena." At the eyepiece, the petty differences of humanity dissolve as our collective place in the universe is put in perspective. We are on this "pale blue dot" together, and helping others realize our common fragile bond is vital.

We encourage you to help others access the stars while you are on your own journey of exploration. The mind-expanding experience you can share can truly make a difference by inspiring others to discover more about the planet, the solar system, the galaxy and the universe we all call home.

Visit www.astronomyoutreach.net today!



EXPLORE[®]
SCIENTIFIC

explorescientificusa.com