



5x30 BINOCULARS
JUMELLES 5x30
FERNGLAS 5x30
PRISMÁTICOS 5x30

BINÓCULOS 5x30
BINOCOLO 5x30
LORNETKA 5x30
VERREKIJKER 5x30

Binocular Instruction Manual
Mode d'emploi des jumelles
Fernglasanleitung
Manual de instrucciones de prismáticos
Manual de instruções binocular
Manuale d'istruzioni del binoculare
Instrukcja obsługi lornetki
Handleiding Verrekijker



5+

5X30

WARNING!

Never look through your binoculars at the sun as this may cause blindness.

AVERTISSEMENT!

Ne regarde jamais le soleil avec les jumelles. Tu pourrais t'aveugler!

ACHTUNG!

Schauen Sie niemals mit Ihrem Fernglas in die Sonne, da dies zu Blindheit führen kann.

¡ADVERTENCIA!

Nunca mires al sol con los prismáticos. ¡Podrías cegarte!

AVISO!

Nunca olhe para o sol com os binóculos, pois pode provocar cegueira.

ATTENZIONE!

Non guardare mai il sole col binocolo, potrebbe causare la cecità.

OSTRZEŻENIE!

Nigdy nie patrz przez lornetkę bezpośrednio na słońce - może to spowodować uszkodzenie wzroku lub nawet całkowitą jego utratę.

WAARSCHUWING!

Kijk nooit door uw verrekijker naar de zon, daar dit uw ogen ernstig zou kunnen beschadigen.

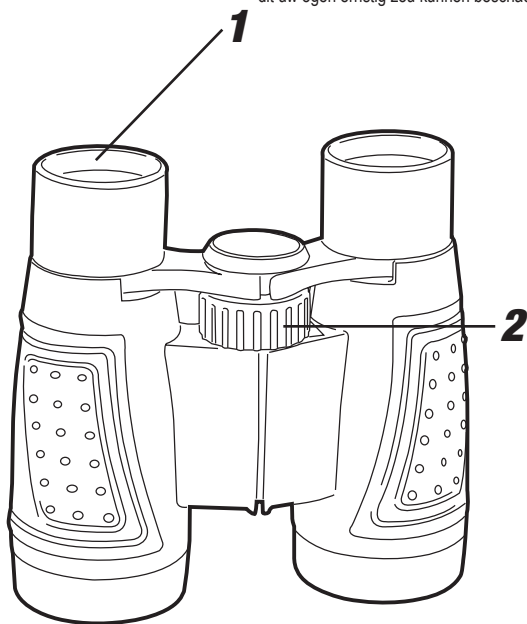

1. Soft rubber eyecups
2. Center focus wheel

How to adjust the distance between your eyes:

The distance between your eyes is called interpupillary distance. It varies from person to person. To achieve perfect alignment of the lenses to the eyes, follow these simple steps.

1. Hold your binoculars in the normal viewing position.
2. Grasp each barrel firmly. Move the barrels closer together or further apart until you see a single circular field. Always reset your binoculars to this position before using. Most binoculars have a graduated area at the top of the center hinge for reference in setting interpupillary distance for subsequent use.
3. You can vary the focus using the center focus wheel and both eyes will always remain in focus. Make note of the diopter setting on the right side for future use.

How to Clean:

1. Blow away any dust or debris on the lens (or use a soft lens brush).
2. To remove dirt or fingerprints, clean with a soft cotton cloth by rubbing in a circular motion. Use of a coarse cloth or unnecessary rubbing may scratch the lens surfaces and eventually cause permanent damage to the binoculars.
3. To thoroughly clean your binoculars, you may use a photographic lens cleaning fluid. Always apply the fluid to the cleaning cloth, never directly onto the lens.

Warning- The lens contains lead that may be harmful. Wash hands after touching.

Product Manual Visit

www.exploreone.com/pages/product-manuals





**Part of the "R"US Family of Brands.
Fait partie de la famille des marques "R"US.
Forma parte de la marce de familia "R"US.
Parte della "R"US Famiglia di Marchi.
Ein Teil der "R" US Familie von Marken.
Czesc "R" US rodzinie marek.
Parte da familia "R" US de Marcas.
Een deel van de "R" US Familie van merken.**

**Contents and colors may vary.
Le contenu et les couleurs peuvent varier.
El contenido y los colores pueden variar.
Contenuti e colori possono variare.
Inhalte und Farben können variieren.
Zawartosc i kolory moga sie różnic.
Conteúdo e cores podem variar.
Inhoud en kleuren kunnen variëren.**

Do not mix old and new batteries. Do not mix alkaline, standard (carbon-zinc), or rechargeable batteries.

Ne mélangez pas les piles neuves et usées. Ne pas mélanger des piles alcalines, standard (au carbone-zinc) piles ou rechargeables.

No mezcle pilas nuevas con pilas usadas. No mezcle pilas alcalinas, estándar (carbone-zinc) ni recargables.

Non mischiare batterie vecchie e nuove. Non mischiare batterie alcaline, standard (carbonio-zinco), o ricaricabili.

Verwenden Sie nicht gleichzeitig alte und neue Batterien. Mischen Sie keine alkalischen, Standard- (Carbonzink) oder Akkus.

Nie mieszaj starych i nowych baterii. Nie należy mieszać baterii alkalicznych, standardowych (cynkowo-węglowych) lub akumulatorków.

Não misture pilhas velhas e novas. Não misture pilhas alcalinas, padrão (carbono-zinco), ou pilhas recarregáveis.

Gebruik geen oude en nieuwe batterijen door elkaar. Gebruik geen alkaline, standaard (koolstof-zink), of oplaadbare batterijen.

EDU SCIENCE IS A MARK OF (EST UNE MARQUE DE/ES UNA MARCA DE) GEOFFREY, LLC, A SUBSIDIARY OF (UNE FILIALE DE/UNA SUBSIDIARIA DE) TOYS"R"US, INC.

© 2015 GEOFFREY, LLC

MADE IN CHINA (FABRIQUÉ EN CHINE/FABRICADO EN CHINA)

DISTRIBUTED IN THE UNITED STATES BY (DISTRIBUÉ AUX

ÉTATS-UNIS PAR/DISTRIBUIDO EN LOS ESTADOS UNIDOS

POR) TOYS"R"US, INC., WAYNE, NJ 07470

IMPORTED BY (IMPORTÉ PAR/IMPORTADO POR)

TOYS"R"US (CANADA) LTD. (LTÉE),

2777 LANGSTAFF ROAD, CONCORD, ON L4K 4M5

DISTRIBUTED IN AUSTRALIA BY (DISTRIBUÉ EN AUSTRALIE

PAR/DISTRIBUIDO EN AUSTRALIA POR) TOYS"R"US

(AUSTRALIA (AUSTRALIE)) PTY LTD.(LTÉE), REGENTS PARK

NSW 2143