



PRODUCT OVERVIEW

Manufactured from structural grade steel with a wall thickness sump this Chemstor[®] storage box is fully compliant with all regulations relating to the safe storage of chemicals and flammables and is ideal for applications where security is an issue. The lid is fitted with twin KALE 156 F safety mortise locks and the unit is finished in electro-static powder coat paint.

Notes: This unit will be delivered by an HGV, possibly articulated therefore please ensure that a vehicle of this type can access your premises before ordering and advise us accordingly.

You will require an appropriate size/capacity fork lift truck to offload this item from the delivery vehicle. Our standard delivery doesn't include any offloading.

SPECIFICATION

CODE	HEIGHT (MM)	LENGTH (MM)	WIDTH (MM)	NO OF DRUMS	COLOUR
CS8	690	1208	675	8 x 25ltr drums	Red

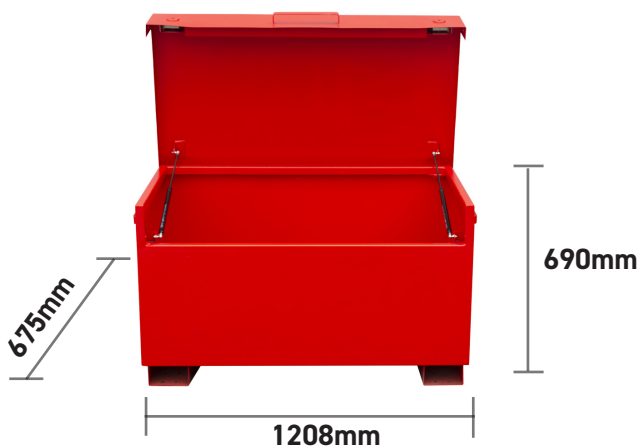



OTHER MODELS AVAILABLE

CS7



CS9

