

duroflex

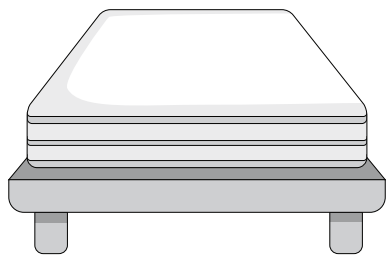

MATTRESS CARE BOOKLET

1



✓ Place mattress in a flat position

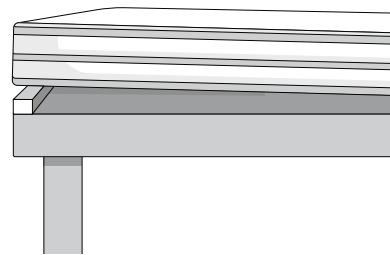

✗ Don't keep mattress in an uneven position

2



✓ Use a mattress protector

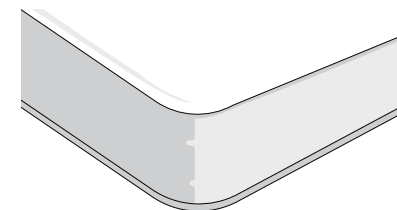

✗ Don't use mattress without a protector

3

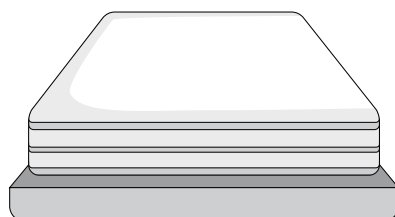

✓ Keep mattress away from smoke

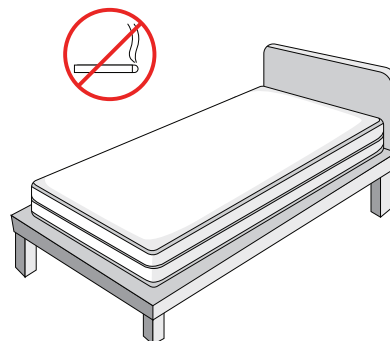

✗ Don't smoke on the bed

4



✓ Use the mattress only to sleep or relax



✗ Don't jump on the mattress or sit on the edges of the mattress

5

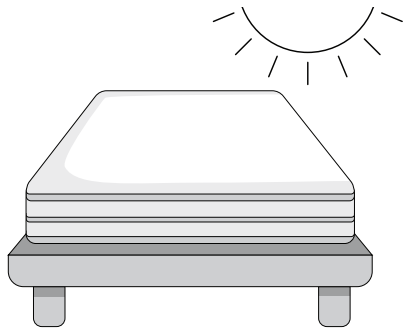

✓ Keep mattress in a dry condition

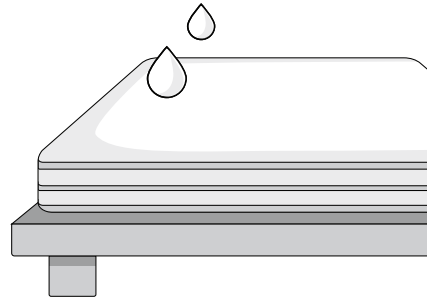

✗ Don't pour any kind of liquid on your mattress

6

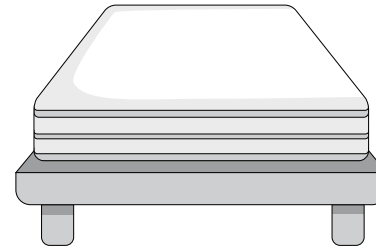

✓ Use mattress in a flat condition

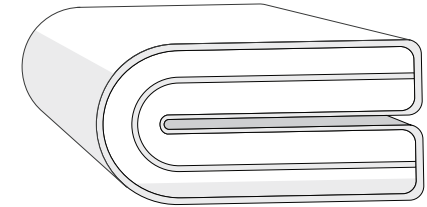

✗ Don't fold the mattress

7

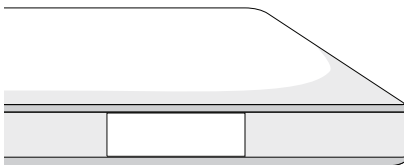

✓ Keep mattress MRP label intact for warranty

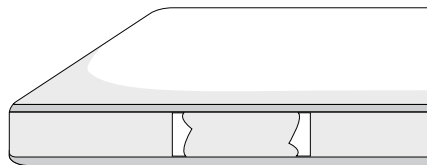

✗ Don't remove MRP label

8

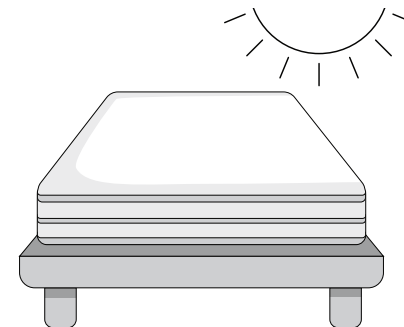

✓ Always sleep on a dry mattress

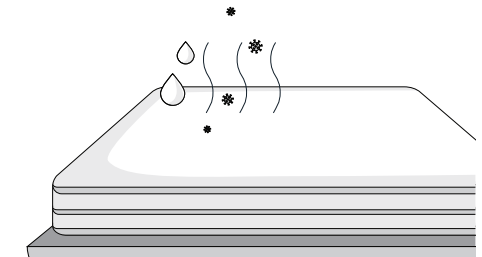

✗ Don't use the mattress if it is partially wet or has a smell

9



✔ Use the mattress only for sleeping and relaxing

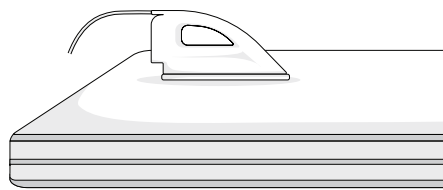

✘ Don't iron or keep any hot substance on the mattress

10

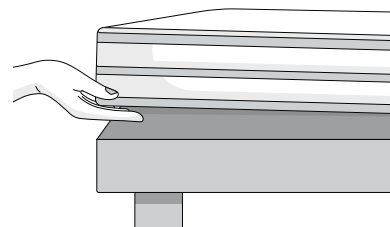

✔ Lift mattress by holding the bottom

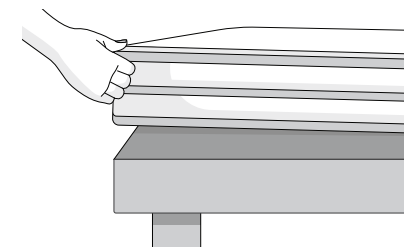

✘ Don't lift the mattress by the beading

11

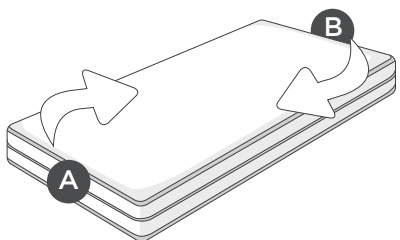

1. 'Rotate' your mattress once in every **3 months** (between side **A** & side **B**)

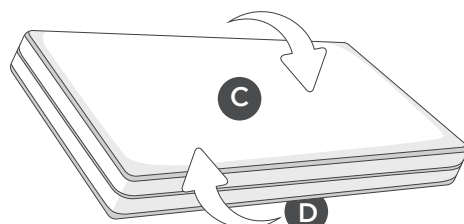

2. 'Flip' your mattress once in every **6 months** (between side **C** & side **D**)

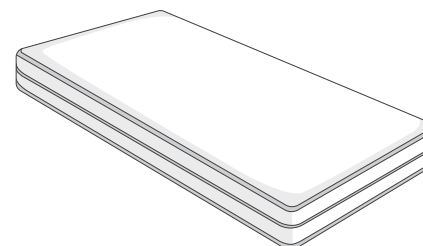

✘ Don't use reversible mattress on one side only

✔ Rotate and flip your reversible mattress as mentioned above