



# USER MANUAL



**HANDLE TYPE  
VACUUM SEALER**  
MODEL NO. MVS-5181

## Warranty Disclaimer 1-Year Warranty Coverage

Magic Mill will repair or replace this product or its parts if found defective within the warranty period. The exclusive 1-year warranty covers repair and replacement of either new or remanufactured products or parts. In any case, the product is no longer available, a similar product of equal or higher value will be used as a replacement.

An unauthorized attempt to modify, repair or adjust the product's electrical or mechanical functions voids its warranty. Damage from negligence, misuse, and mishandling of the product that violates its standard use according to the instructions outlined in this User Manual is not covered by the 1-year warranty.

Proof of purchase is required to activate the product warranty. The date of initial retail purchase in the original sales receipt or invoice will determine warranty validity. Warranty is limited to its original purchaser and not transferable.



We Guarantee 100% Product Satisfaction

If for any reason you are not 100% satisfied with your order, our Customer Service Department is always ready to assist you.

Contact us Directly and Avoid Third-Party Hassle

**Email us:** [support@magicmillusa.com](mailto:support@magicmillusa.com)

or

**Call, Text, or Whatsapp:** @ 1-888-364-8550

Our Customer Support will help you out until you are 100% satisfied with our product, or you'll get your money back.

## Table of Contents

What's Included in the Box-----Page 4

Important Safeguards-----Page 5-6

Technical Data-----Page 6

Product Construction-----Page 7

Product Functions-----Page 8-10

Operating Instructions-----Page 11-14

Cleaning and Maintenance-----Page 15

Thawing and Reheating Tips-----Page 16

Food Preparation Guidelines-----Page 17-18

Vacuum Sealing of Non-Food Items-----Page 19

Troubleshooting-----Page 20

Disposal of Device-----Page 21

## What's Included in the Box

### Handle Type Vacuum Sealer



### Accessories

1-roll 8.6" x 16.40" Vacuum Bags

1-roll 11.02" x 16.40" Vacuum Bags

1-pc Vacuum Tube

1-pc Hose Adaptor

1-pc Wine Stopper

1-pc Extra Lower Gasket

## Important Safeguards

When using this electrical appliance, always observe safety precautions and the following safety instructions:

1. Carefully read and follow the operating instructions provided in this User Manual.

2. Ensure that the control is OFF. Check the control status before plugging/unplugging the cord into the electrical outlet. **Note:** *Always unplug the cord from the outlet before cleaning the appliance or when not in use.*

3. Keep this appliance out of reach of children. Close attention is necessary when using this product near children. **Note:** *This is not a toy.*

4. Do not use any attachments that are not recommended in this user manual. If you want to know more about attachment recommendations, contact our Customer Service directly.

5. Do not use the appliance for purposes other than its intended use.

6. Stop using the appliance when the electrical cord is damaged and have it immediately replaced by a professional.

7. When the appliance is running, ALWAYS keep away from moving parts.

8. Always ask for professional help, and do not try to repair this appliance yourself.

9. Do not use the appliance if it has fallen or if it appears to have any damage.

10. Do not pull or carry the appliance by the cord or use it as a handle, close the door on it, or pull it around sharp edges and corners.

11. Do not use the appliance when the cord/plug is wet.

12. Keep it away from hot gas, heated oven, electric burner, or other hot surfaces.

13. A short power supply cord is provided to lower the risk of any tripping incident or electrical cord entanglement. Extension cords can be used, but the electrical rating should be no less than the marked electrical rating of the appliance, and longer cords should be arranged and secured properly.

14. Unplug the appliance by grasping the plug (not the cord) to avoid injury.

15. Before plugging/unplugging the appliance, ensure your hands are dry for a safe product operation.

16. Place the appliance on a stable surface to have a secure operation when it is "ON" or in a working position.

17. Using any lubricant like lubricating oils or water on this appliance is not necessary.

## Important Safeguards cont.

18. Do not use water or any other liquid material when cleaning the appliance.
19. Do not use the appliance outdoors or on wet surfaces. It is recommended for household and indoor use only.
20. The appliance is not intended to be used by children or persons with reduced physical, sensory or mental capabilities or lack of experience and knowledge unless given close and strict supervision or instructions by a person responsible for their safety.
21. The manufacturer, service agent, or similarly qualified person should repair and replace the product and its accessories to avoid troubleshooting hazards.
22. Do not change the polarized plug in any way. The plug is designed to fit in a polarized outlet in one way to reduce the risk of electrical shock.  
**Note:** *If it still does not fit, contact a qualified electrician to install the proper outlet.*

## Save these Instructions

**CAUTION:**  
FOR HOUSEHOLD/INDOOR USE ONLY

## Technical Data

<b>Device</b>
Hande Type Vacuum Sealer
<b>Model No.</b>
MVS-5181
<b>Voltage</b>
120V~60Hz
<b>Power Consumption</b>
120W
<b>Net Weight</b>
~4.63 Lbs
<b>Product Dimensions</b>
15.93" L x 7.72" W x 4.72" H
<b>Max. Vacuum Pressure</b>
-80Kpa
<b>Pump Volume</b>
15L/min

## Product Construction

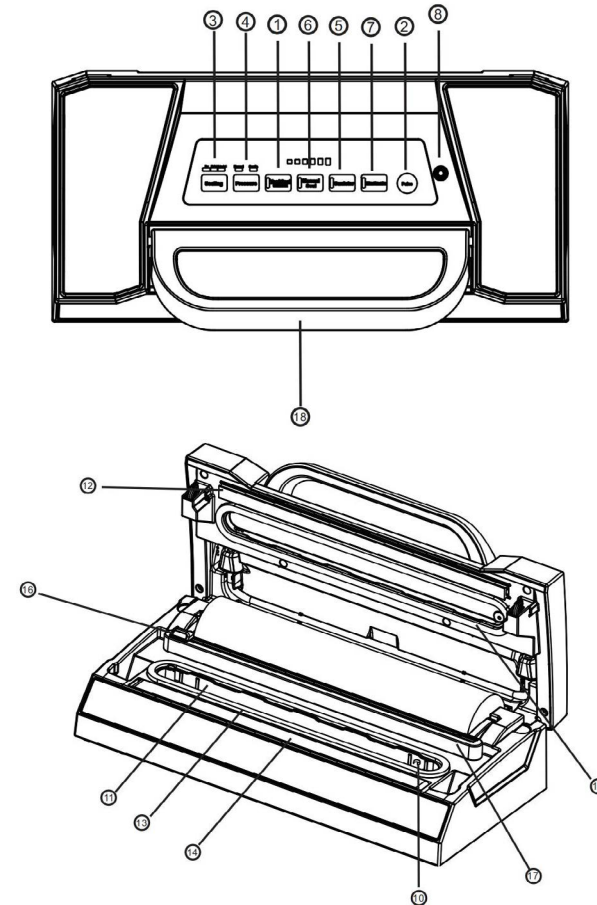

- |                         |                    |                     |
|-------------------------|--------------------|---------------------|
| 1. Vacuum & Seal/Cancel | 7. Marinate        | 13. Lower Gasket    |
| 2. Pulse                | 8. Hose Port       | 14. Sealing Element |
| 3. Sealing Time         | 9. Progress        | 15. Upper Gasket    |
| 4. Pressure             | 10. Air Intake     | 16. Bag Cutter      |
| 5. Canister             | 11. Vacuum Chamber | 17. Cutter Rack     |
| 6. Manual Seal          | 12. Sealing Strip  | 18. Front Handle    |

## Product Functions

### 1. Vacuum & Seal / Cancel:

This button has two functions depending on the machine's status:

- **Standby Status** - it starts the automatic operation of vacuuming the bag and then seals it when the vacuum operation is complete.
- **Working Status** (Vacuuming or Sealing Operation) - it cancels or stops the current operation of the machine.

### 2. Pulse:

This button controls the vacuum pressure manually and works best for foods with moisture, more liquid content or are softer, more delicate, or fragile. Press this button to start the vacuum process and release it to stop. Repeat pressing and releasing the button until the desired vacuum pressure is met. To seal the bags, press the "**Manual Seal**" button.

**Tips:** Choose the "**Moist**" Option for things with more liquid content. Immediately release the "**Pulse**" button when liquid starts to go upside and press the "**Manual Seal**" button to seal the bag. If liquid has already been sucked into the bag edge area, repeat the "**Manual Seal**" without opening the cover to ensure the sealing effect.

### 3. Sealing Time:

This button has three settings with different bag sealing times.

- **Dry** - It has a shorter sealing time which is suitable for dry bags and items without moisture.
- **Moist** - It has a longer sealing time which is suitable for moist bags or foods with little moisture.
- **Extended Button** - It has an extended sealing time which is suitable for moist bags or foods with more moisture.

**Note:** The normal default setting is for dry bags and shorter sealing time.

### 4. Pressure:

This button has two settings with different vacuum pressures.

- **Normal** - It has a higher vacuum pressure suitable for storing regular/dry food.
- **Gentle** - It has a lower vacuum pressure to avoid crushing soft, fragile, and moist food when stored.

**Note:** The default setting is "**Normal**" with high vacuum pressure.

## Product Functions cont.

### 5. Canister:

This button controls the vacuum pressure when vacuuming canisters, jar lids, wine stoppers, or other accessories through a hose tube.  
**Note:** Please ensure your accessories can match our hose tube or not before purchase.

### 6. Manual Seal:

This button has two functions:

- To seal the open end of a bag without vacuuming air suction (this function is used to make a bag from a bag roll).
- When the automatic "**Vacuum & Seal**" function is in operation, this button stops the motor pump and directly starts sealing the bag to limit the vacuum pressure inside the bag to avoid crushing delicate items. **Note:** The operator controls vacuum pressure.

### 7. Marinate:

This button works by connecting the vacuum tube to a Marinate bowl. Press this button to the vacuum sealing process, which helps marinate food faster. After 5 marinating cycles, the machine will automatically stop the vacuum sealing process. **Note:** Ensure that the vacuum container you have is a Marinate Bowl.

### 8. Hose Port:

A socket where the hose tube will be inserted to perform vacuum sealing on containers for "**Marinate**" or "**Canister**" operations. **Note:** Properly insert hose tubes to avoid air leakage when vacuum sealing.

### 9. Progress:

These LED lights have two functions:

- Indicates the progress of the vacuum sealing process
- Indicates that the device is ON and the lid is closed.

**Note:** When the LED flickers, wait until it is steady before you can start the next operation.

### 10. Air Intake:

It connects with the vacuum chamber and motor pump. **Note:** Do not cover this intake when placing a bag for Vacuum and Seal operations.

### 11. Vacuum Chamber:

It is where to put the mouth of the bag so the air can be drawn out.

### 12. Sealing Strip:

It is a strip where the bags are sealed. **Note:** Clean, dry, or replace it when distorted or broken.

## Product Functions cont.

### 13. Lower Gasket:

It keeps air away by forming a vacuum chamber with the upper gasket in the vacuum chamber. **Note:** Clean, dry, or replace it when distorted or broken.

### 14. Sealing Element:

A Teflon-coated heating element that seals the bags.

### 15. Upper Gasket:

It keeps the air away by forming a vacuum chamber. **Note:** Clean, dry, or replace it when distorted or broken.

### 15. Upper Gasket:

It keeps the air away by forming a vacuum chamber. **Note:** Clean, dry, or replace it when distorted or broken.

### 16. Bag Cutter:

Press and slide in one direction or vice versa to cut bags to the desired size.

### 17. Cutter Rack:

Cutter support where the cutter slides along.

### 18. Front Handle:

Press the handle down to easily lock the cover into the base or lift the handle to open the cover. **Note:** Do not lock the handle when the product is not used to avoid deforming the gasket.

## Operating Instructions

### I. Making a Bag with Bag Roll

1. Open the machine and locate the bag roll storage area, then check if you have an available bag roll inside.

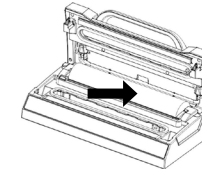

2. Pull out the end of the bag roll to the desired length underneath the cutter rack. Press and slide the bag cutter from one side to another to cut the bag according to the desired size.

**Note:** If you have a precut bag, it can work with the machine directly.

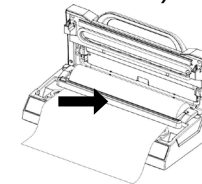

3. Put one end of the bag on top of the sealing element without reaching the vacuum chamber

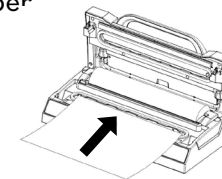

4. Close the cover and press the handle to lock the cover into the machine base.

4. cont.

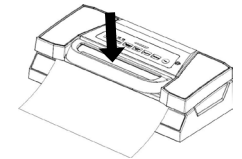

5. Press the “Manual Seal” button to start sealing the bags. The indicator light indicates the sealing process is ongoing.

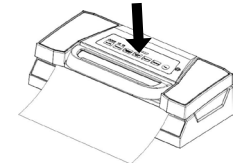

6. When the indicator light turns off, sealing is done. Lift the handle to open the cover and take the newly sealed bag out of the machine. Pack the necessary foods into the bags, and it is ready for vacuum sealing.

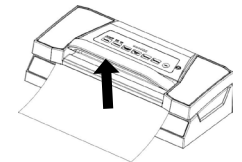

**Tip:** Food that requires oxygen to prolong its shelf life, like fruits and fresh vegetables, is unsuitable for vacuum storage.

### II. Vacuum Packaging with a Bag

1. Put suitable foods inside the bag. Only use the specially designed vacuum bags supplied by us with vacuum channels. **Note:** Flat bags without air channels will not work on the machine.

## Operating Instructions cont.

- Clean and straighten the bag's open end, ensuring no dust, wrinkle, or ripples on the bag's mouth area.
- Place the open end of the bag within the vacuum chamber area. Make sure the bags do not cover the air intake.

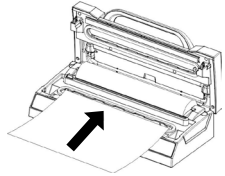

- Press down the handle to lock the machine cover into the base.
- Check the LED status of the food to confirm sealing time depending on the moisture status of packed food if either Dry or Moist.
- Press the **"Vacuum & Seal / Cancel"** button to start vacuuming, then seal the bag automatically. Check the indicator light to know if the vacuum and sealing process is done.

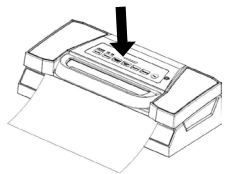

- When the indicator light Turns off, the vacuum and sealing process is done. Lift the handle to open the cover and take the bag out of the machine.

### Tips :

- Check if the bag is perfectly sealed or not before putting it into the refrigerator for long storage.
- To avoid crushing delicate items during packaging by the very high vacuum pressure of the machine, always observe the vacuum pressure inside the bag and immediately switch to the **"Manual Seal"** button when the desired vacuum pressure is achieved. The pump will stop and change to heating and sealing the bag.

### Notes:

- Wipe out any excess liquid or food residue in the vacuum chamber after each bag is packed.
- Your appliance can only work on the specific bags recommended in this User Manual. Do not attempt to use other bags not intended for vacuum packaging.
- When packaging food with sharp edges & bones, wrap it with food-grade paper before the vacuum process to avoid sharp edge punctures that can cause a vacuum bag air leakage.

## Operating Instructions cont.

### III. Pulse & Moist Functions

This function manually controls the vacuum pressure for food containing more moisture and liquid, which are very soft, delicate, and fragile.

#### Pulse Button

- Long-press the **"Pulse"** button to start the vacuum process.
- Release the **"Pulse"** button to stop the vacuum process. **Note:** Repeat this process until you meet the desired vacuum pressure.
- Press the **"Manual Seal"** button to seal the vacuumed bag. **Tips:** If the food has more liquid content, choose the **"Moist"** option.

#### Moist Button

- Press the **"Moist"** Button to start the vacuum process.
- Immediately release the button when the liquid goes near the bag's mouth.
- Press the **"Manual Seal"** button to seal the vacuumed bag. **Tip:** If the liquid has been sucked into the edge area of the bag, repeat the **"Manual Seal"** process to ensure that the bag is properly sealed.

### IV. Canister & Bowl Vacuum Function

#### Canister Vacuum Process

- Ensure the canister or bowl's body and cover are clean and dry.
- Put the food into the canister but do not fill it up so the cover will be in good contact with the canister rim.
- Clean the canister's cover rim and its bottom seal gasket.
- Insert one end of the hose tip into the machine's hose port and the other end of the hose adaptor on the canister cover

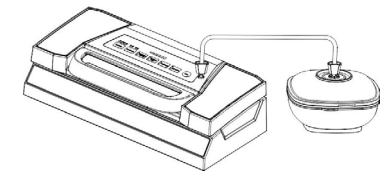

- Press the **"Canister"** button to start the vacuum process. The machine will automatically stop when enough vacuum pressure is achieved.
- After completing the vacuum process, remove the hose adaptor from the canister cover and the machine's hose port.

## Operating Instructions cont.

### IV. Marinate Food with a Marinate Bowl

1. Ensure the Marinate bowl's body and cover are clean and dry.
2. Put the marinade mixture and the meat in the bowl and cover it.
3. Insert one end of the hose tube into the machine's hose port and the other end of the hose adaptor on the marinate bowl cover.
4. Push down the handle to lock the machine cover.
5. Press the **"Marinate"** button to start the marinating process. The machine will begin the vacuum process and release air automatically within 5 cycles. It takes 6 minutes to complete a marinating process. **Note:** *To manually stop the marinating process, press the **"Vacuum & Seal/Cancel"** Button.*
6. After completing the vacuum process, remove the hose adaptor from the canister cover and the machine's hose port.

### Opening a Vacuumed Package or Canister

To open a vacuumed canister or package, release the air first, then remove the canister cover.

### Canister Function Notes:

1. Before the vacuum process, slightly press the cover or the hose down to ensure the hose is not loose and no air leakage between the canister cover and rim gap.
2. To know if the hose is tight, simply tug the canister cover, and if it doesn't move, you can start the vacuum process.
3. Different canisters are available in the market. Refer to the canisters user manual for each brand's specific operating procedures.
4. Ensure that the vacuum canister hose tip matches the vacuum machine before purchase.

### V. Cord Storage

Put the power cord at the cord storage found at the back of the machine, and do not wrap the cord around the machine when not in use.

## Cleaning & Maintenance

### Vacuum Sealer

1. Always unplug the unit before cleaning.
2. Do not immerse the machine in water or any other liquid.
3. Avoid using abrasive products or materials to clean the unit, for they will scratch the surface.
4. Use mild dishwashing soap and a warm, damp cloth to remove food and dirt residues.
5. Dry thoroughly before using the machine again. **Note:** *The foam gaskets around the vacuum chamber should be dried thoroughly before reassembling. When reassembling, be careful to prevent damage and assemble in the original position to ensure no vacuum leaks.*

### Vacuum Bags

1. Wash bags with warm water and mild dishwashing soap.
2. Turn the bags inside out and spread them over the top rack when washing the bags in the dishwasher to expose the entire surface to the washing water.

3. Dry the bags thoroughly before reusing them. **IMPORTANT:** *To avoid possible health issues, do not reuse bags after storing raw meat, fish, or greasy foods. Do not reuse bags that have been microwaved, boiled, or cooked Sous vide.*

### Storing Your Vacuum Sealer

1. Keep the unit in a flat and safe place, out of the reach of children.
2. Remember to ensure the appliance's lid is unlocked when not in use and storage. Keeping the cover locked will distort the foam gaskets, which can cause leakage.



## Thawing & Reheating Tips

### Thawing Vacuum-Sealed Foods

Thaw foods in three different ways:

- 1. In a refrigerator:** place the vacuum-sealed food on a plate inside your refrigerator hours before cooking.
- 2. In cold water:** submerge the vacuum-sealed bag in a large bowl of cold water and change the water once it feels warm.
- 3. In a microwave:** remove the vacuum-sealed packaging, put the food in a container, and then select the defrost option.

**Tip:** Cook the food immediately after thawing to avoid contamination.

**Note:** Perishable foods should never be thawed under room temperature, for bacteria present before freezing can begin to multiply if the temperature becomes warmer than 40 °F.

### Reheating Vacuum-Sealed Foods

There are three safe ways to reheat these foods:

- In an oven:** put the food in the oven and set it to at least 325 °F.
- On a stovetop:** put the food in a pan and heat it properly until it reaches at least 165 °F.

- In a microwave:** put the food on a plate and heat it until it reaches at least 165 °F.

**Note:** Reheating cooked and cooled food should reach at least 140 °F. Low heating temperatures can cause bacteria to multiply rapidly.

## Food Preparation Guidelines



### Meat and Fish

Keep meat and fish in a freezer for about 1-2 hours before vacuum-sealing them. Freezing the meat preserves it longer, and with the help of the vacuum sealing process, no air can contaminate your food. **Note:** Red meat tends to turn darker after the vacuum process. It changes color due to a lack of oxygen in the bag, but it is safe to be consumed.



### Hard Cheese

Vacuum sealing cheesing is a good way to preserve cheese because it locks moisture and keeps out air. Wrap the cheese in parchment paper before putting it in a bag for vacuum sealing. The paper absorbs excess moisture and preserves the cheese for at least a few months. **Note:** Vacuum sealing soft cheese is not recommended, for it develops mold easily in an airless environment.



### Vegetables

Before vacuum-sealing vegetables, a blanching process should be done. After blanching the vegetables in hot water, plunge them into ice-cold water to perform the process called Shocking. Then let the vegetables dry before vacuum sealing them. **Note:**

Blanching vegetables also help extend their shelf life and pasteurize them to avoid freezer burn if it is stored too long in a freezer.



### Leafy Vegetables

Vacuum sealing leafy vegetables and refrigerating them can double their usual shelf life. Before the vacuum sealing process, cut and wash the vegetable, then let it dry using paper towels or a salad spinner. For best results, blanch them before sealing. Using vacuum canisters for leafy vegetables is recommended to keep them from crushing. **Note:** Blanching cruciferous vegetables like cauliflower, cabbage, and kale is necessary before vacuum sealing because they emit gasses that can cause spoilage.



### Soft Fruits

Vacuum sealing may crush soft fruits like berries and papayas in the process. To avoid this, put them in a freezer for 1-2 hours after washing them. Once the fruits have undergone freezing, vacuum sealing can be performed.



### Sturdy Fruits

For sturdier fruits, freezing is not necessary. Simply wash the fruits, let

## Food Preparation Guidelines cont.

them dry, cut them into pieces (if the size won't fit the vacuum bag), then vacuum seal.



### Baked Goods

For soft and airy baked goods, put them in a freezer until hard enough to retain their shape during the vacuum sealing process. Freezing soft baked goods is not required if a vacuum canister is used. For dry baked goods like pie and cookie dough, you can directly vacuum-seal them in a bag.



### Liquids

Liquids (like soup and stock) should be frozen using ice cube trays or a popsicle mold before vacuum-sealing them. Keep the vacuum package in the freezer and reheat it until it boils if you will consume the soup.



### Coffee and Powdery Goods

Vacuum sealing powdery foods like coffee can extend shelf life and aroma. To vacuum seal powdery foods, put a paper towel at the mouth of the bag to avoid drawing in the powder in the machine. To increase storage life, freezing it after vacuum sealing can help. If you only intend to consume and keep the aroma of the coffee, use a vacuum canister and put it in the

pantry. **Note:** *Vacuum sealing and freezing coffee increases its shelf life by 8-10x.*



### Leftovers and Make-Ahead Meals

Using vacuum canisters for leftovers is the most efficient way. Put it directly in the fridge or freezer after vacuum sealing and thaw and reheat them accordingly to avoid any health concerns. There are microwavable vacuum canisters that can be used as storage for your make-ahead meals. Simply reheat it in a microwave, and you're ready to go.



### Grains and Nuts

Vacuum sealing nuts and grains will help them last longer by removing the air from the packaging. Nuts and grains should be cleaned and dried before vacuum sealing and freezing them. A vacuum bag and canister are good storage for grain and nuts.



### Snack Foods

Using vacuumed packages for your snack foods can maintain their freshness and crispness. Using vacuum bags is good for solid snacks, but for airy snacks, Vacuum Canister is the best option to avoid crushing them during vacuum sealing.

## Vacuum Sealing of Non-Food Items

Vacuum sealing is not limited to foods, but it is also effective in the following non-food items:



### Utensils

Vacuum sealing silverware reduces the chance of developing tarnishes due to oxidation and exposure to other chemicals in the air. Before vacuum sealing, utensils should be cleaned, dried, and covered with smooth paper towels (if it has sharp edges to avoid tearing). Vacuum sealing is additional protection to keep silverware in good condition.



### Traveling or Camping

Vacuum sealing maximizes the number of things you can bring when traveling and camping. Fabric items like clothes and towels reduce their size when vacuum sealed, giving space for other camping items you need. Vacuum sealing fire starter supplies is also effective in keeping it dry and safe from water bottle leaks and rain.



### Medical Supplies

Vacuum Sealing and storing medicine in a cool and dry place preserves its effectiveness longer. When it comes to other medical kits, and emergency items like gauze and band-aids,

vacuum sealing them prevents cracking and leakage because it dries out faster when exposed to air.



### Jewelry

The most effective way to keep the tidiness and spark of your jewelry is by vacuum sealing it. Fine pieces or even costume jewelry should be vacuum sealed when not regularly used to avoid oxidation which can make it loosen its spark and become darker. Vacuum-sealed jewelry doesn't need polishing and cleaning when you are ready to wear it.



### Important Documents

Waterproofing important documents like passports, certificates, and even cash are the primary reason for vacuum sealing them. Water and even moisture can affect the quality of a paper, which may cause it to turn yellow and the texts to fade.

## Troubleshooting

Problem	Solution
<b>Vacuuming but seal function is not good</b>	<b>Check if the edge of the bags has liquid, oil stain or any chippings.</b> If yes, please clean the edge of the bags and try again.
	<b>Check if the heating element is damaged and in a good setting or not.</b> If damaged, please exchange the heating element and make sure it is installed properly.
	<b>Check if the sealing strip is damaged or properly installed.</b> If damaged, please exchange the sealing strip and make sure it is installed properly.
	<b>Check if the edge of the bag has wrinkles.</b> If yes, please remove some food out of the bag to have enough space for sealing then smooth the bag's mouth and try again.
<b>Seal function is good but not vacuuming</b>	<b>Check if the gasket is deformed.</b> If deformed, replace it and try again.
	<b>Check if the bags are placed into the vacuum chamber.</b> If not, please put the edge of the bags into the vacuum chamber.
	<b>Check if the food has sharp edges.</b> If yes, please pack the food with safe paper before vacuuming the bag.
	<b>Check if the edge of the bag covered the suction hole.</b> If yes, please put the bag in the correct position.
<b>Bag inflates after vacuuming</b>	<b>Check if the food is quickly perishable goods.</b> All fast perishable goods must be frozen or refrigerated after vacuuming to prolong their shelf life. <b>Note:</b> <i>Vacuuming doesn't guarantee the food will never spoil.</i>
	<b>Check if you packed fresh vegetables, fruit, and seeds.</b> All fresh vegetables, fruit, and seeds are not suitable for room temperature storage after vacuuming. <b>Note:</b> <i>Vacuumed packages should be refrigerated because they will perspire at room temperature and cause the seeds to grow.</i>
<b>Bag Melts</b>	<b>Check if the sealing time is too long.</b> If yes, please reset the sealing time.

## Disposal of the Device

### Protection of the Environment

At the end of the life of your product, it should go to a specially adapted waste-recycling center.

1. The symbol on the product or its packaging indicates that this product may not be treated as household waste. Instead, it should be handed over to the applicable collection point for recycling electrical and electronic equipment.
2. By ensuring this product is disposed of correctly, you will help prevent potential negative environmental and human health consequences, which could otherwise be caused by inappropriate waste handling. For more detailed information about recycling this product, please contact your local council office or your household waste disposal service.

Making Magic Since 1968



 | [www.magicmillusa.com](http://www.magicmillusa.com)

 | 888-364-8550

 | [support@magicmillusa.com](mailto:support@magicmillusa.com)