

BRAUN®

FOOD PROCESSOR



Owner's Manual

1 YEAR WARRANTY

Manufacturer warrants, subject to the conditions stated below, that from the date of purchase, this product will be free from mechanical defects for a period of ONE (1) year. Manufacturer, at its option, will repair or replace this product found to be defective during the warranty period. Should this product become defective by reason of improper workmanship or material defect during the specified warranty period, Manufacturer will repair or replace the same effecting all necessary parts replacements for a period of one year from the date of purchase. Transportation charges on parts, or products in whole, submitted for repair or replacement, under this warranty, must be borne by the purchaser.

CONDITIONS: This warranty is valid for the original USA retail purchaser from the date of initial retail purchase and is not transferable. Keep the original sales receipt. Proof of purchase is required to obtain warranty service or replacement. Dealers, service centers, or retail stores do not have the right to alter, modify or in any way, change the terms and conditions of this warranty. Warranty registration is not necessary to obtain warranty on Manufacturer Products. Save your proof of purchase receipt.

ABOUT YOUR PRODUCT WARRANTY: warranty service does NOT apply if the product damage occurred because of misuse, lack of routine maintenance, shipping, handling, warehousing or improper installation. Similarly, the warranty is void if the manufacturing date or the serial number on the product has been removed or the equipment has been altered or modified. During the warranty period, the authorized service dealer, at its option, will repair or replace any part that, upon examination, is found to be defective under normal use and service.

NORMAL WEAR: This warranty does not cover normal wear of parts or damage resulting from any of the following: negligent use or misuse of the product; improper voltage or current; use contrary to the operation instructions; deviation from instructions regarding storage and transportation; repair or alteration by anyone other than Manufacturer or an authorized service center. Further, the warranty does not cover Acts of God, such as fire, flood, hurricanes and tornadoes. Manufacturer shall not be liable for any incidental or consequential damages caused by the breach of any express or implied warranty. Except to the extent prohibited by applicable law, any implied warranty of merchantability or fitness for a particular purpose is limited in duration to the duration of the above warranty. Some states, provinces or jurisdictions do not allow the exclusion or limitation of incidental or consequential damages or limitations on how long an implied warranty lasts, so the above limitations or exclusion may not apply to you. This warranty gives you specific legal rights, and you may also have other rights that vary from state to state or province to province.

HOW TO OBTAIN WARRANTY SERVICE: If your appliance should prove to be defective within the warranty period, we will repair it, or if we think necessary, replace it. To obtain warranty service, simply call our Customer Service Representatives; 855.927.4383, or send the defective product to Customer Service to the following address: 103 Pleasant Avenue • Upper Saddle River, NJ 07458.

For Parts & Service In
The USA Contact Us:



855.927.4383
service@braunpartsusa.com

IMPORTANT SAFEGUARDS

This appliance is for **HOUSEHOLD USE ONLY**.

When using an electrical appliance, basic safety precautions should always be taken, including the following:

1. **READ ALL INSTRUCTIONS BEFORE USE.**
2. Unplug from outlet when not in use and before cleaning.
3. Avoid contacting moving parts.
4. To protect against fire, electric shock and injury to persons, **DO NOT IMMERSE CORD, PLUG OR BASE UNIT** in water or other liquids.
5. Close supervision is necessary when any appliance is used by or near children. Do not allow children to operate the appliance.
6. Do not operate any appliance with a damaged cord or plug, or after the appliance has malfunctioned or has been damaged in any way. Return appliance to the nearest authorized service facility for examination, repair or adjustment.
7. The use of accessory attachments not recommended by Braun may result in fire, electric shock or injury to persons.
8. Do not use outdoors.
9. Do not let power cord hang over edge of table or counter, or touch hot surfaces.
10. Do not place on or near a hot gas or electric burner, or in a heated oven.
11. Always operate the appliance on a smooth, even and stable surface.
12. Do not use appliance for anything other than intended use.
13. Use extreme caution when operating any appliance with sharp blades or attachments.
14. Always ensure the voltage on the rating label corresponds to the voltage in your home.
15. This appliance has a polarized plug (one blade is wider than the other). To reduce the risk of electric shock, this plug is intended to fit into a polarized outlet only one way. If the plug does not fit fully into the outlet, reverse the plug. If it still does not fit, contact a qualified electrician. Do not attempt to modify the plug in any way. Always unplug the appliance when not in use.
16. Ensure all moving parts have completely stopped before removing food from the food processor.

SAVE THESE INSTRUCTIONS

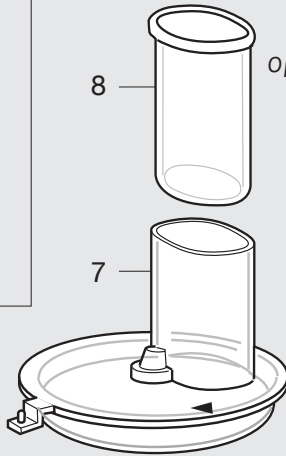
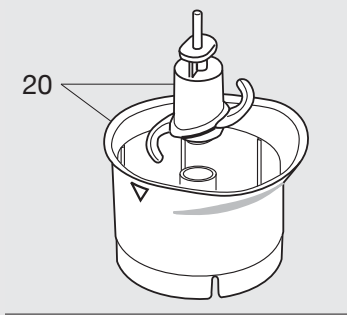
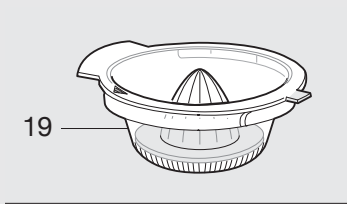

Optional

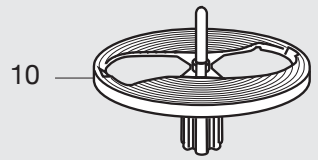

Optional

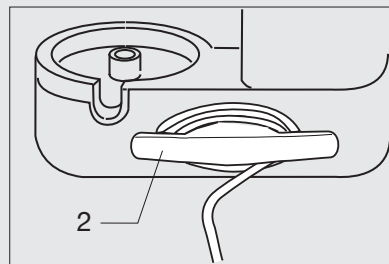
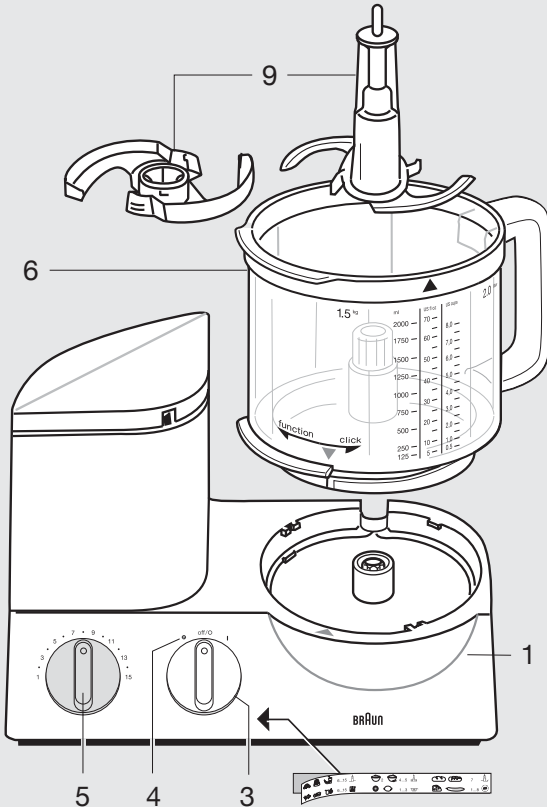
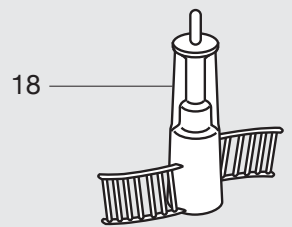
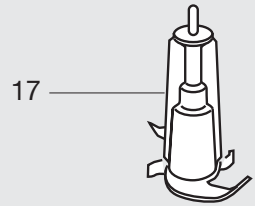

PARTS & ATTACHMENTS

1. Motor Block
2. Cord Storage
3. Motor Switch (On/I Off/O)
4. Pulse Mode (P)
5. Variable Speed Regulator (1-15)
6. Food Processor Bowl (12 cup capacity)
7. Lid for Food Processor Bowl
8. Pusher For Lid
9. Blade With Protective Cover
10. Insert Carrier
11. Fine Slicing Insert - a
12. Coarse Slicing Insert - b (*Optional*)
13. Fine Shredding Insert - c
14. Coarse Shredding Insert - d
15. Grating Insert - e
16. French-Fries System (*Optional*)
17. Kneading Hook
18. Whipping Attachment
19. Citrus Press
20. Chopper Attachment

OPERATING INSTRUCTIONS

READ ALL INSTRUCTIONS BEFORE USE

CAUTIONS:

- This appliance is designed for household use only and for processing normal household quantities.
- Blades are sharp. Handle carefully!
- Keep hands, hair, clothing, as well as spatulas and other utensils away from beaters (knife assembly) during operation to reduce the risk of injury to persons, and/or damage to the mixer. Remove beaters (knife assembly) from mixer before washing.
- Never feed food into the processor by hand, always use food pusher.
- To avoid injury, never place cutting blade or discs on base without first putting bowl properly in place.
- Be certain cover is securely locked in place before operating appliance.
- Do not attempt to defeat the cover interlock mechanism.

DIRECTIONS:

Before using the food processor for the first time, clean all parts as described under "Cleaning & Maintenance".

1. With the motor switched off, place the food processor bowl onto the drive place on the motor block by matching the arrow on the bowl with the arrow on the motor block. Turn the bowl in the "function" direction as far as it will go. See figure A

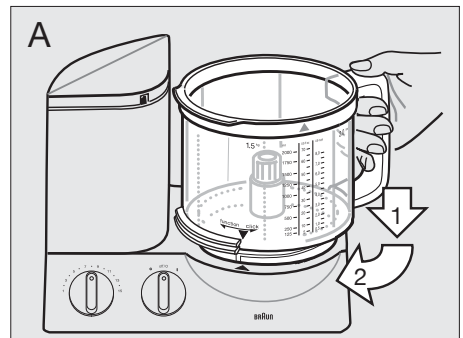

2. Put desired attachment onto drive shaft of the bowl and push it down as far as it will go.

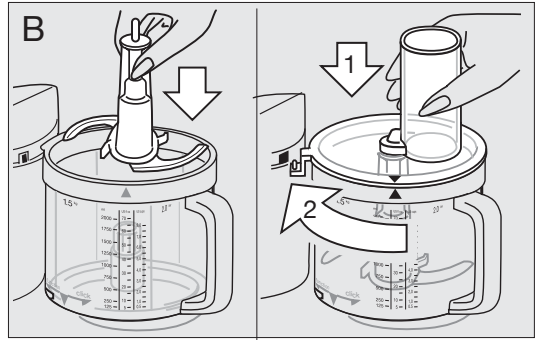

3. Put the lid onto the bowl matching the arrow on the lid with the arrow on the bowl. Turn the lid clockwise guiding its nose rim into the safety lock opening of the motor block until it audibly snaps into place. See Figure B

4. Set the speed range by means of the variable speed regulator. It is recommended to first select the speed and then switch on the appliance in order to work with the desired speed from the beginning. See figure f

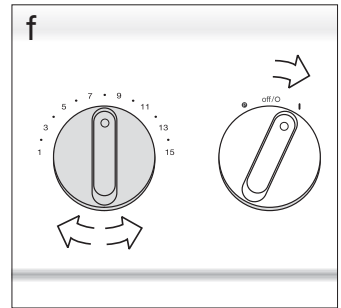

5. Fill the food processor bowl with ingredients. *Note: In order to avoid damages caused by overload, this appliance is equipped with an automatic security switch which shuts off the current supply if necessary. In such case, turn the motor switch back to off "O" and wait approximately 15 minutes to allow the motor to cool off before switching on the appliance again.*

6. Switch the motor to the on position "I". See figure f. *Note: The appliance can only be switched on when the food processor bowl and the lid is properly engaged. If the lid is opened during operation, the motor switches off automatically. In this case the motor switch is still on "I", turn it back to "O" to avoid switching on the motor accidentally.*



7. To remove the food processor bowl switch off the appliance, turn the lid counterclockwise and lift off. Turn the food processor bowl in the "click" direction until it unlocks, lift off the bowl.

Pulse Function **P**

The pulse mode is useful for the following applications: Chopping delicate and soft food - eggs, onions, or parsley, carefully folding flour into dough or batter to maintain the creaminess, or adding whipped eggs or cream to more solid food.

1. The pulse mode is activated by turning the motor switch to the pulse position **P** (to the left). The switch does not catch at this setting. Hold the switch in pulse position or turn it to pulse position repeatedly.
2. Before activating the pulse mode, set the desired speed with the speed regulator. When releasing the pulse mode the appliance is switched off.

KNEADING

 17 - Kneading Hook — OR —  9 - Blade	<p>For kneading you can use the kneading hook, or the blade. For best results, we recommend using the kneading hook which is specially designed for making yeast dough, pasta, and pastries. Use the chart below for kneading dough.</p> <p>CAUTION: Do not use the kneading hook for heavy mixtures such as cake.</p>
---	---

Dough	Max Capacity	Speed	Time
Yeast Dough	2 cups flour plus other ingredients	7	1½ Min
Pasta Dough	2 cups flour plus other ingredients	7	1½ Min
Pastries	2 cups flour plus other ingredients	7	1 Min

Yeast Dough (*Breads & Cakes - use blade*)

1. Pour flour into the food processor bowl, then add other ingredients except liquids.
2. Put on the lid and lock into place. Set the food processor to speed 7 and switch the appliance on.

3. Add liquids by pouring them through the filling tube of the lid while the motor is running.

Note: when kneading with the blade, do not add ingredients like raisins or nuts which are not supposed to be cut. These have to be added manually after removing the kneaded dough from the food processor bowl.

Pasta Dough

1. Pour flour into the food processor bowl, then add other ingredients except liquids.
2. Put on the lid and lock into place. Set the food processor to speed 7 and switch the appliance on.
3. Add liquids by pouring them through the filling tube of the lid while the motor is running.

Note: Do not add any liquid after the dough has formed into a ball as then the liquid will no longer be absorbed evenly.

Pastries

1. Pour flour into the food processor bowl, then add other ingredients. For best results, butter should not be too hard or too soft.
2. Put on the lid and lock into place. Set the food processor to speed 7 and switch the appliance on.
3. Stop kneading the dough shortly after a ball has formed. Otherwise the pastry dough will become too soft.

MIXING



9 - Blade

For mixing cake dough or sponges use the blade. The kneading hook is not suitable for mixing cake doughs or sponges. Max capacity 2 cups flour plus other ingredients.

Cake Mixtures

Method One:

1. Cream butter, sugar, and eggs on speed 6 for 1 minute

2. Pour in milk on speed 6 for 15 seconds.
3. Set the food processor to speed 15, using the "pulse" function, carefully fold in flour; pulse 10-15 times.

Method Two:

1. Pour all ingredients except liquids into the food processor bowl, process ingredients on speed 15 for 1 minute.
2. Add liquids through the filling tube of the lid while the motor is running.
3. Add ingredients like raisins and nuts manually.

Sponge Doughs

1. Cream eggs and water on speed 15 for 2 minutes.
2. Add sugar and process on speed 15 for 4 minutes.
3. On speed 8, fold in flour using the pulse function 5 times.
4. Add cocoa powder using the pulse function 3 times.

BLENDING



9 - Blade

Use the blade for blending soups and shakes etc. Do not fill the processor bowl above 2 L to keep the bowl from overflowing.

1. Pour coarsely chopped fruit into the food processor bowl.
2. Put on the lid and lock into place. Set the food processor to speed 15 and switch the appliance on.
3. Set the food processor to speed 10, add liquid through the filling tube and process until blended.

Note: When blending milk, please note that it will froth. Use smaller quantities.

CHOPPING

Processing times in the chart on the next page are approximate and depend on the quality, the amount of food to be processed and the required degree of fineness.

Chopping With The Blade





Product	Max Amount	Preparation	Speed	Mode	Time/Pulse
Hard Bread Rolls	4	Quartered	15		45 secs
Ice Cubes	28	Whole	15		1 min
Apples	4 Cups	Quartered	8		15 secs
Chocolate Cool	2 Cups	Broken	15		Coarse: 15 sec, Fine: 30 sec
Eggs	8	Whole	6	Pulse	8x
Cheese (Soft)	2 Cups	3cm Cubes	15		20 sec
Cheese (Hard)	4 Cups	3cm Cubes	15		60-70 sec
Meat	4 Cups	Inch Cubes	15		40 sec
Carrots	4 Cups	Inch Pieces	15		10 sec
Onions	4 Cups	Quartered	15	Pulse	10-13x

Chopping With Chopper Attachment

Recommended quantity: max. 1 cup. When processing large pieces of food, first use the pulse mode, then continue with the highest speed until you reach the desired degree of fineness. Do not chop hard foods such as coffee beans or nutmeg.

Product	Recomm. Quantity	Preparation	Speed	Mode	Time/Pulse
Herbs	4	Without Stems	15		5-10 secs
Onions	1	Quartered	6	Pulse	5x
Cheese (Hard)	½ Cup	Inch Pieces	15		45 secs
Nuts	½ Cup	Whole	15		30 sec
Salad Dressing		Chop herbs	7		5-10 sec
Mayonnaise	Max. 1 egg	Mix egg, seasoning, mustard, vinegar, add oil slowly while motor is running.	15		60 sec
Baby Food (veggies/ fruits)		Raw or cooked, no hot food	15		20-30 sec

SLICING, SHREDDING, GRATING

Insert	Speed	Processing Examples
11. a - Fine Slicing 	1-2	Cucumbers, Cabbage, Raw Potatoes, Carrots, Onions, Radishes
12. b - Coarse Slicing (<i>Optional</i>) 	1-2	Cucumbers, Kohlrabi, Raw Potatoes, Onions, Bananas, Tomatoes, Mushrooms, Celery
13. c - Fine Shredding 	3-6	Cheese (soft to medium), Cucumbers, Carrots, Raw Potatoes, Apples
14. d - Coarse Shredding 	3-6	Cheese (soft to medium), Cucumbers, Kohlrabi, Beetroot, Carrots, Raw Potatoes, Apples, Cabbage
15. e - Grating 	8-15	Raw Potatoes, Horseradish, Parmigiano Cheese (hard)

- Place the insert you want to use into the insert carrier and snap into position (see figure C). In order to remove the insert, push up the insert end that protrudes at the bottom of the insert carrier.
- Press the assembled slicer/shredder onto the drive shaft of the food processor bowl (see figure D).
- Put the lid onto the bowl and lock into place. Set the speed and fill the food to be processed into the filling tube while the motor is switched off. Refilling should be done with the motor switched off.

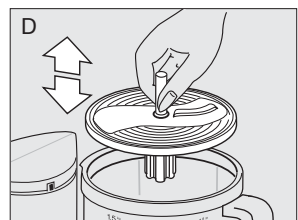
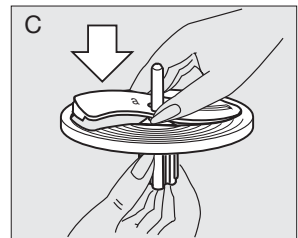

4. Never reach into the filling tube when the motor is running. Always use the pusher (see figure E).

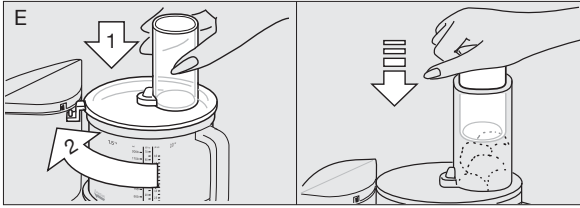

Note: When processing juicy or soft food, you will obtain better results at a lower speed. Hard food should be processed at a higher speed. Do not overload the processor bowl. Refer to the chart below to choose the appropriate attachment for desired food to be processed.

WHIPPING



18 - Whipping Attachment

Use the whipping attachment for light whipping only. Use the kneading attachment or blade for whipping heavy mixtures.

Whipping Sponges - Max 2½ cups flour plus ingredients

1. Cream eggs and water on speed 5 for 2 minutes.
2. Add sugar on speed 5 for 2 minutes
3. On speed 1 fold in flour for 30 seconds.

Whipping Egg Whites

- Min 2 egg-whites: speed 4-5 for 4 minutes
- Max 6 egg-whites: speed 4-5 for 6 minutes

Whipping Cream

- Min 0.15-0.2: speed 2 for 1-2 minutes
- Max 0.4: speed 2 for 3½ - 4 minutes

Note: Before whipping sterilized cream, keep the cream cool for several hours

JUICING



19 - Citrus Press

Use the citrus juicer to make fresh squeezed juice.
Use caution when pressing juice, do not press too hard.

1. Remove lid from food processor bowl (See figure a).

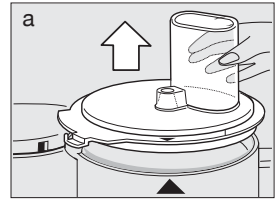

2. Attach citrus press to food processor bowl by aligning the arrow on the citrus press with the arrow on the food processor bowl, then rotate the citrus press clockwise (see figure b).

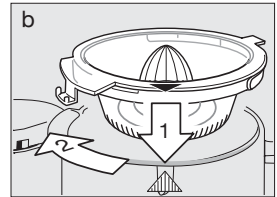

3. Cut citrus fruit (orange, grapefruit, lemon, etc.) in half. Set the food processor speed to 3 and turn on. Juice fruit by pressing fruit halves onto citrus press until all the fruit juice is gone from the fruit (See figure c). Repeat until desired amount of juice is acquired.

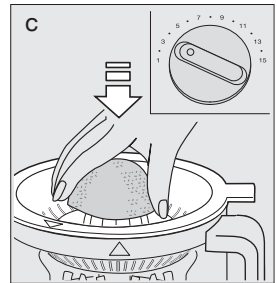

4. To pour your fresh juice, rotate citrus press counter-clockwise (see figure d).

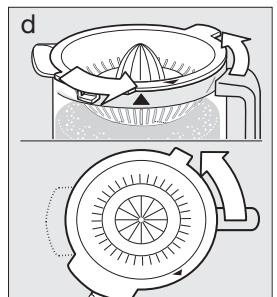

5. Hold citrus press in place and pour freshly squeezed juice into a clean glass (see figure e).

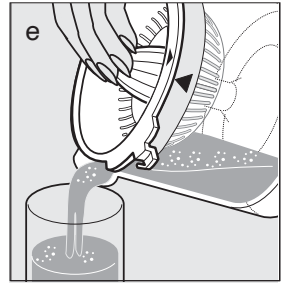

5. To remove citrus press from food processor bowl rotate the citrus press to align the arrows on the citrus press and the food processor bowl and lift (see figure f).

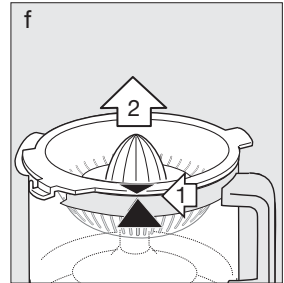

CLEANING & MAINTENANCE

Always make sure to switch off the motor and unplug the appliance. Clean the motor block with a damp cloth only. Blades are sharp! Use caution when cleaning the blades.

- **Hand wash only. DO NOT WASH ANY PART OF THE UNIT IN THE DISHWASHER!**
- Color-intensive food such as carrots may leave stains on the plastic parts; wipe them off with cooking oil before cleaning with water.
- Do not use sharp objects for cleaning purposes.
- Clean the blades and the inserts very carefully - they are very sharp! Take hold of the knob only.

DO NOT SUBMERGE THE BASE UNIT OR CORD INTO WATER OR ANY OTHER LIQUID OR THIS MAY DAMAGE THE FOOD PROCESSOR.

RELIABLE CARE SERVICE CENTER
2 Alpine Ct STE 102 • Chestnut Ridge • NY 10977
855.927.4383 | service@braunpartsusa.com