



Woodworking Machinery & Accessories





RIKON WARRANTY

RIKON Power Tools Inc. ("Seller") warrants to only the original retail consumer/purchaser of our products that each product be free from defects in materials and workmanship for a period of five (5) from the date the product was purchased at retail. This warranty may not be transferred.

This warranty does not apply to defects due directly or indirectly to misuse, abuse, negligence, accidents, repairs, alterations, lack of maintenance or normal wear and tear. Under no circumstances will Seller be liable for incidental or consequential damages resulting from defective products. All other warranties, expressed or implied, whether of merchantability, fitness for purpose, or otherwise are expressly disclaimed by Seller. This five-year warranty does not cover products used for commercial, industrial or educational purposes. The warranty term for these claims will be limited to a two-year period.

This limited warranty does not apply to accessory or consumable items such as blades, drill bits, sanding discs, grinding wheels, guide bearings, belts and other related items.

Seller shall in no event be liable for death, injuries to persons or property, or for incidental, contingent, special, or consequential damages arising from the use of our products.

To take advantage of this warranty, proof of purchase documentation, which includes date of purchase and an explanation of the complaint, must be provided.

The Seller reserves the right to effect at any time, without prior notice, those alterations to parts, fittings, and accessory equipment which they may deem necessary for any reason whatsoever.

Unless otherwise noted, product names, designs, logos, titles, text, images and other media within this catalog are the trademarks, service marks, trade names, copyrights or other property of RIKON Power Tools, Inc. ("RIKON Power Tools' Intellectual Property"). All other unregistered and registered trademarks are the property of their respective owners. Nothing contained in this catalog should be construed as granting, by implication, estoppel, or otherwise, any license or right to use any of RIKON Power Tools' Intellectual Property displayed in this catalog without the written permission of RIKON Power Tools.

RIKON Power Tools is not responsible for any incorrect information provided within this catalog. The specifications, photographs, drawings and information represent the current models when the catalog was prepared. Changes and improvements may be made at any time, with no obligation on the part of RIKON Power Tools, Inc. to modify previously delivered units. All items purchased from RIKON are made pursuant to a shipment contract. This means that the risk of loss and title for such items pass to you upon our delivery to the carrier.

This catalog was developed in the United States of America in accordance with and shall be governed by, and your browsing in and use of this catalog shall be deemed acceptance of the laws of the State of Massachusetts, United States of America.

* RIKON and RIKON Power Tools are registered trademarks of Rikon Power Tools, Inc.

© Copyright RIKON Power Tools, Inc., Billerica, MA.

Reproduction in whole or part of this catalog without prior written authorization is prohibited.

Table of Contents

Bandsaws	4 - 11
Meat Saw	12
Scroll Saw	13
Table Saws	14 - 15
Saw Accessories	16 - 17
Planers & Jointers	18 - 25
Drill Presses	26 - 31
Mortiser	32
Drill Press & Mortiser Accessories	33
Lathes	34 - 37
Lathe Accessories	38 - 39
Wet Sharpener	40 - 41
Buffers	40 - 41
Grinders	42 - 43
Sanders	44 - 49
Sander Accessories	50
Dust Collectors	51 - 53
Air Filtration	54 - 55

Accessories are listed at the end of each section or on their product pages

RIKON Bandsaws 10" & 14"



10-305

Shown with Optional
Stand (13-913)



10-324

Model No.	10-305 10" Bandsaw	10-324 14" Bandsaw
MOTOR		
Horsepower	1/3 HP	1-1/2 HP TEFC
Amps	4.5	14/7
Volts	110V, 60 Hz	115V / 230V, 60 Hz
CUTTING CAPACITY		
Height	4-5/8"	13"
Width	9-5/8"	13-5/8"
BLADE		
Width Range	1/8" – 1/2"	3/16" – 3/4"
Length	70-1/2"	111"
Speed Range	2,780 FT/MIN	1,445 / 2,950 FT/MIN
Supplied on Machine	5/16" x 6 TPI, Regular	5/8" x 4 TPI, Regular
TABLE		
Size	13-3/4" x 12-1/2"	21-1/2" x 15-3/4"
Left Tilt	0°	-5°
Right Tilt	45°	45°
Miter Gauge Slot(s)	(1) 5/8" x 3/8"	(2) 3/4" x 3/8"
Height to Base / Floor	14-1/2" / 39-7/8" (On Stand)	20" / 39-1/2" (On Stand)
Fence Size (LxWxH)	13-1/2" x 1" x 2"	18-3/4" x 1-7/8" x 6"
OVERALL		
Height	33-1/4"	75"
Width	21"	30"
Depth	15-1/4"	25"
Base Size	9-3/8" x 15-7/8"	21-5/8" x 14-3/4"
Dust Port	1 @ 2-1/2"	1 @ 4"
Net Weight	68 lbs.	212 lbs.
Shipping Weight	76 lbs.	223 lbs.
Shipping Carton (LxWxH)	35-1/2" x 12-3/4" x 18-1/4"	54" x 17-1/2" x 23-5/8"
WARRANTY	5 YEARS	5 YEARS

Features

These two Bandsaws for the home workshop give reliable, straight forward operation for cutting small detail work, patterns, blanks and also thicker stock. Ample sized tables and ball bearing blade guides give good user-control during operation. Made of solid steel column and frame construction. Wired for use with 3-wire 120V receptacles.

10" Bandsaw #10-305 is a favorite of woodworkers and hobbyists that do not require large cutting capacity and power for their projects, or have limited shop space for a larger size bandsaw. Includes features for easy operation – tilting 0-45° table, rip fence, large blade tension knob, dust port for shop vacuum hookup, and safety paddle on/off switch. Reduced size is ideal for transporting, or storing, when not in use. Includes rip fence. Steel stand (#13-913) and a miter gauge are available separately.

14" Bandsaw #10-324 offers woodworkers increased cutting capacity, power and versatility at an entry level price. Dual voltage, 1 HP motor drives the balanced cast aluminum wheels at your choice of two speeds for standard cutting all types of woods, or for working with non-ferrous materials. Tilting table with two 'T' slots allow the use of a miter gauge (available separately) or other cutting jigs on both sides of the blade. Includes 6" high rip fence with re-saw bar and steel stand with lower shelf. EXCLUSIVE: Legs of the stand can be cut down 11-1/2" to lower the saw for woodworkers confined to wheelchairs.

Standard Features

- Rugged steel frames
- Balanced cast aluminum drive wheels
- Dependable 60Hz motors
- Machined cast iron tables with miter gauge slots
- Easy Access blade tension systems
- Rack and Pinion upper guide adjustments
- Dust collection ports

Optional Accessories

- 10-900 Spring Loaded Tool-Less Retrofit Kit (For 10-324 and 10-325 Only)
- Miter Gauges
- Rip Fences
- Mobility Kits
- Table Inserts
- Bandsaw Blades
- LED Light with Magnetic Base



Balanced Cast Aluminum Wheels

Precision Guide Bearings

Large Cast Iron Work Tables

Accessories listed on pages 17-18

RIKON Bandsaws 14"



10-326

Shown with Optional
Mobility Kit (13-325)



10-353

Shown with Optional
Mobility Kit (13-345)

Model No.**10-326**

14" Deluxe Bandsaw

10-353

14" Professional Bandsaw

MOTOR

Horsepower	1-3/4 HP TEFC	3 HP TEFC
Amps	14/7	13
Volts	115V / 230V, 60 Hz	220V, 60 Hz

CUTTING CAPACITY

Height	13"	14"
Width	13-5/8"	13-5/8"

BLADE

Width Range	1/8" - 3/4"	3/16" - 1"
Length	111"	142"
Speed Range	1,445 / 2,950 FT/MIN	4,300 FT/MIN
Supplied on Machine	5/8" x 4 TPI, Regular	5/8" x 4 TPI, Regular

TABLE

Size	21-1/2" x 15-3/4"	21-1/2" x 15-3/4"
Left Tilt	-7°	-10°
Right Tilt	45°	45°
Miter Gauge Slot(s)	(2) 3/4" x 3/8"	(2) 3/4" x 3/8"
Height to Base / Floor	20-7/8" / 40-1/2"	34-5/8"
Fence Size (LxWxH)	18-3/4" x 1-7/8" x 6"	19-11/16" x 1-7/8" x 6"

OVERALL

Height	76"	74-1/2"
Width	33-3/4"	33-1/2"
Depth	25"	28-1/2"
Base Size	24" x 17-5/8"	25-1/4" x 18-1/8"
Dust Port	1 @ 4"	2 @ 4"
Net Weight	285 lbs.	315 lbs.
Shipping Weight	293 lbs.	414 lbs.
Shipping Carton (LxWxH)	54-1/2" x 17-7/8" x 23-7/8"	75-5/8" x 30" x 21-1/4"

WARRANTY**5 YEARS****5 YEARS****Features**

14" Bandsaws have proven to be the most popular size in the bandsaw category, because the cutting capacities, power and general overall size of the machines fit the majority of the work requirements of the professional and novice craftsperson. Saws are designed to take a wide range of bandsaw blade widths that are used for making small detailed cuts, sawing dense hardwoods & composites, re-sawing timber, or even working with plastics and non-ferrous metals. Pre-lubricated, sealed thrust and side ball bearing guides give smooth blade support during difficult cuts. Saws are constructed with a solid steel welded main column and support frames for extra rigidity and stability.

14" Bandsaw #10-326 is RIKON's newest model with many Patent Pending features that professionals will enjoy - including spring-loaded tool-less blade guides, quick-adjust fence system and quick-lock trunnion table angling system, plus, a quick release blade tension lever, large adjustment handles, hinged safety blade guard with sight window, high work table height, and storage cabinet base. Its dual voltage, 1-3/4HP motor provides ample power for most every work encountered. Designed with two speed options – just change the drive belt on the pulleys to change from fast to a slower blade speed. Includes 6" tall rip fence with re-saw bar. Wired for use with 3-wire 120V receptacles.

14" Bandsaw #10-353 features an impressive 3HP motor and the largest cutting capacity in this model range, which makes this saw ideal for use in re-sawing lumber, as well as handling normal shop work. Designed with extra user friendly and safety features – Patent Pending tool-less blade guide system, quick-adjust fence system and quick-lock trunnion system for fast table angle setting, plus, a keyed power switch (great for unauthorized use & security), emergency OFF foot switch pedal, door activated emergency stop micro switch, conveniently located blade tension release lever with the tensioning wheel under the top frame, large work table with two miter gauge 'T' slots, hinged blade guard, and clear sight window for easier viewing when adjusting the blade. Includes 6" rip fence with re-saw bar. Requires a 220V 3-wire electrical plug to match your electrical receptacle.

Standard Features

- Rugged welded steel columns and frames
- Balanced cast iron drive wheels
- Machined cast iron tables with dual miter gauge 'T' slots
- Quick-release blade tension systems
- Large blade tension hand wheels
- Spring loaded tool-less upper & lower bearings
- Lower wheel dust cleaning brushes
- 4" Dust collection ports

Optional Accessories (Specs listed on pages 17-18)

- Miter Gauge
- Mobility Kits
- Table Inserts
- Bandsaw Blades
- LED Light with Magnetic Base



Balanced Cast Iron Wheels



Spring Loaded Tool-Less Guide System



Quick Adjust 6" Tall Rip Fence System



Quick Lock Cast Iron Trunnion System



Emergency Foot Brake on #10-353

Accessories listed on pages 17-18

RIKON Bandsaws 18"



10-342

Shown with Optional
Mobility Kit (13-345)



10-347

Shown with Optional
Mobility Kit (13-345)

Model No.**10-342**

18" Deluxe Bandsaw

10-347

18" Professional Bandsaw

MOTOR

Horsepower	2 HP TEFC
Amps	7.5
Volts	220V, 60 Hz, 1Ph

4 HP TEFC
16
220V, 60 Hz

CUTTING CAPACITY

Height	13"	19"
Width	17-1/2"	17-1/2"

BLADE

Width Range	1/4" - 1-3/8"	1/4" - 1-3/8"
Length	153"	162"
Speed Range	3,280 FT/MIN	4,920 FT/MIN
Supplied on Machine	5/8" x 3 TPI, Regular	3/4" x 4 TPI, Regular

TABLE

Size	21-1/2" x 15-3/4" with 4-3/8" x 15-3/4" extension	25" x 19"
Left Tilt	-10°	-5°
Right Tilt	45°	45°
Miter Gauge Slot(s)	(2) 3/4" x 3/8"	(1) 3/4" x 3/8"
Height to Floor	35-1/2"	33-1/2"
Fence Size (LxWxH)	20-7/8" x 1-7/8" x 6"	18-3/4" x 1-7/8" x 6"

OVERALL

Height	72-7/8"	82-1/4"
Width	38-1/2"	35"
Depth	28-1/8"	30"
Base Size	29-5/16" x 18-1/8"	29-15/16" x 18-1/8"
Dust Port	2 @ 4"	2 @ 4"
Net Weight	324 lbs.	498 lbs.
Shipping Weight	464 lbs.	536 lbs.
Shipping Carton (LxWxH)	33-3/4" x 22-1/4" x 79-3/8"	35-1/4" x 25" x 84-1/4"

WARRANTY**5 YEARS****5 YEARS****Features**

18" Bandsaws have become increasingly popular as greater ripping widths and increased power are needed for handling larger sized lumber, panels or timbers used in cabinetmaking, carpentry and other trades. A definite step-up from its 14" brothers, these professional grade bandsaws are made to take these work demands. Constructed of heavier box-style, welded steel columns and reinforced frames which contribute to the added stiffness needed to withstand the tensions from sawing tough, dense or thicker materials. Rear quick-release tension lever and large blade tension hand wheel, conveniently located under the top frame, make adjusting the blade easy. All models have higher HP 220V motors that require either 3-wire or 4-wire electrical plugs to match your electrical receptacles.

18" Bandsaw #10-342 is an entry level machine to this larger capacity category. Ample 2 HP motor provides plenty of power behind the single 3,200 ft/min blade speed of the machine. Cast iron table includes a single 'T' slot for use with miter gauges (available separately) or other cutting jigs. Includes 120V electrical outlet on rear of machine. Machine requires 4-wire electrical plug.

18" Bandsaw #10-347 has the most powerful motor in its class, 4HP, which makes it ideal for woodworkers doing a lot of heavy re-saw work. Professional features include spring-loaded tool-less blade guides, quick-adjust fence system, massive cast iron table, geared cast table trunnion, substantial 6" high rip fence and re-saw bar, key activated safety on/off switch, micro safety on/off switch activated door & foot brake. Under the top door blade tension release levers with blade tension hand wheel are easy to access from the front of the saw.

Standard Features

- Rugged welded steel columns and frames
- Machined cast iron tables with 'T' slots
- Extruded Aluminum 6" tall rip fences with re-saw bars
- Quick-release blade tension systems
- Large blade tension hand wheels
- Spring loaded tool-less upper & lower guide bearings
- Lower wheel dust cleaning brushes

Optional Accessories

- Miter Gauge
- Mobility Kits
- Table Inserts
- Bandsaw Blades
- LED Light with Magnetic Base



Balanced Cast Iron Wheels

Spring Loaded Tool-Less Guide System

Large Cast Iron Work Tables

Quick Lock Cast Iron Trunnion System

Accessories available on pages 17-18

RIKON

Bandsaw 18"

**10-370**Shown with Optional
Mobility Kit (13-345)**Model No.****10-370**

18" Wood / Metal Bandsaw

MOTOR

Horsepower	2-1/2 HP
Amps	12.5
Volts	220V, 60 Hz

CUTTING CAPACITY

Height	12"
Width	18-3/8"

BLADE

Width	1/4" - 1-1/4"
Length	142"
Speed Range	82-328 / 1,312-3,280 FT/MIN
Supplied on Machine	5/8" x 4 TPI, Regular

TABLE

Size	21" x 19"
Left Tilt	-10°
Right Tilt	45°
Miter Gauge Slot(s)	(2) 3/4" x 3/8"
Height to Floor	37-3/4"
Fence Size (LxWxH)	20-7/8" x 1-7/8" x 6"

OVERALL

Height	76"
Width	38-7/16"
Depth	29-1/2"
Base Size	29-15/16" x 18-1/8" x 2-7/16"
Dust Port	2 @ 4"
Net Weight	372 lbs.
Shipping Weight	434 lbs.
Shipping Carton (LxWxH)	35-3/4" x 21-5/8" x 79"

WARRANTY**5 YEARS****Features**

18" WOOD/METAL Bandsaw #10-370 is a favorite of professional shops for the wide range of electronically controlled blade speeds that can be set with a simple twist of a dial. This means that the best results can be easily obtained for each of the variety of materials that can be cut and shaped with this machine – all woods, composites, plastics and all metals. Plus, this saw has plenty of power for slicing through substantially thicker lumber for roughing out bowl, spindle, seat blanks or construction timber. The wide cutting capacity, large adjustable tilting cast iron table, double ball bearing upper & lower blade guides, and rugged fence system make work efficient.

Features an electronic break that stops the blade in less than 5 seconds (pending blade speed). Saw is constructed of a heavy, welded steel column and reinforced frames for extra rigidity and support. Dual "T" slots and rugged 6" high rip fence system allows fast arranging of set-ups for making duplicate or multiple cuts. 220V motor requires a 3-wire electrical plug to match your electrical receptacle.

Standard Features:

- Rugged welded steel column and frame
- Balanced cast iron drive wheels
- Powerful 2-1/2 HP motor
- Dual blade speed ranges
- Machined cast iron table with "T" slots
- Rack and Pinion table angle adjustment
- Large extruded aluminum rip fences with re-saw bar
- Solid steel front guide rail system make fence adjustments easy
- Quick-release blade tension system
- Large blade tension hand wheel
- Rack and Pinion upper guide adjustment
- Lower wheel dust cleaning brush
- Dual 4" dust collection ports

Optional Accessories – see pages 17-18

- Miter Gauge
- Mobility Kit
- Table Inserts
- Bandsaw Blades



Easy Adjust Table Tilt System



Precision Guide Bearings

6" High Rip Fence With
Resaw BarPower Switch With Speed
Control Knob and Digital Display

Balanced Cast Iron Wheels

RIKON

Bandsaw 24"

**10-385**

Includes Mobility Kit



Tool-less Precision Blade Guides Set Fast and Easy



Massive Cast Iron Table with 6" Tall Rip Fence



Powerful 5.5 HP Motor Won't Bog Down on Thick Cuts



Huge, Balanced Cast Iron Wheels

Model No.**10-385**

24" Bandsaw

MOTOR

Horsepower	5-1/2 HP
Amps	15
Volts	220V, 60 Hz, 3 Ph

CUTTING CAPACITY

Height	14-1/2"
Width	22-7/8"

BLADE

Width Range	3/8" - 1-3/8"
Length	176"
Speed Range	4,920 FT/MIN
Supplied on Machine	176" x 5/8" x 4 TPI, Regular

TABLE

Size	27-3/8" x 23-3/4" (Table Extension 23-3/8" x 7")
Left Tilt	-10°
Right Tilt	45°
Miter Gauge Slot	(1) 3/4" x 3/8"
Height to Floor	33-7/8"
Fence Size (LxWxH)	22-1/2" x 1-3/4" x 6"

OVERALL

Height	80"
Width	47"
Depth	35"
Base Size	39-3/8" x 18-1/8"
Dust Ports	2 @ 4"
Net Weight	726 lbs.
Shipping Weight	870 lbs.
Shipping Carton (LxWxH)	44" x 30-1/2" x 85"

WARRANTY**5 YEARS**

Features

This Professional 24" Bandsaw offers additional features over the other bandsaws in the RIKON line. It provides great cutting capability for workshops that deal with wide panels to substantially thicker lumber. This brute has the power to tackle the hardest materials and all types of woods, composite materials and plastics with its big motor. Saw is constructed of a heavy, welded steel column and reinforced frame for extra rigidity and support. Tall rip fence glides and sets easily on the husky front rail support. 220V 3 Phase Motor requires a power cord and electrical plug to match your electrical receptacles.

24" Bandsaw #10-385 is a machine on steroids, designed with over-sized features to take the demands of cutting through thick, dense and large materials. Fabricating facilities, woodworkers dealing with re-sawing logs, or cutting bowl blanks for turning will appreciate the power that the 5.5HP motor and drive system offers. Balanced, heavy cast iron wheels keep the power and cutting momentum going better than any other saw in its class. Patent-pending tool-less blade guides make setting of the large, double ball bearings to the blades an easy task. Foot pedal brake helps slow down and stopping the saw quickly, when needed. The saw also features the newest, 'anti-drift' fence system with 6 inch tall fence for the best support and fine tuning for ripping stock. Double 4" dust ports efficiently collect the sawdust generated during work. Note: Size and weight of this machine will require help to initially move and set up this machine. The table alone weighs an impressive 130 lbs!

Standard Features:

- Rugged welded steel column and frame
- Balanced cast iron drive wheels
- Powerful 3 Phase 220V 5.5 HP motor
- Machined cast iron table with 'T' slot
- Rack and Pinion table angle adjustment
- Large extruded aluminum rip fence with re-saw bar
- Solid steel front guide rail system makes fence adjustments easy
- Quick-release blade tension system
- Large blade tension hand wheel
- Rack and Pinion upper guide adjustments
- Lower wheel dust cleaning brush
- Dual 4" dust collection ports
- Includes mobility kit and miter gauge

Optional Accessories:

- Miter Gauge
- Table Inserts
- Bandsaw Blades

Accessories available on pages 17-18

RIKON

Meat Saw

**10-308**

Rear View



Includes Meat Grinder Attachment

Model No.**10-308**

Meat Saw

MOTOR

Horsepower	3/4 HP
Amps	5
Volts	110V, 60 Hz

CUTTING CAPACITY

Height	8-1/2"
Width	9-5/8"

BLADE

Width	5/8"
Length	76-3/4"
Speed Range	984 FT/MIN
Supplied on Machine	5/8" x 4 TPI, Regular, S.S.

TABLE

Size	27-7/16" x 17-5/16"
Height to Floor	35-5/8"
Fence Size (HxL)	2-3/4" x 6" & 2-3/4" x 9-3/8"

GRINDER

Mouth	4-1/2"
Throat	2-1/4"
Plate Size	#8 - (2-3/8" Diameter)
Plate Holes Size (included)	4.5 mm Diameter

OVERALL

Height	57-1/2"
Width	21"
Depth	22-3/4"
Base Size	19" x 16-1/2"
Net Weight	128 lbs.
Shipping Weight	138 lbs.
Shipping Carton (LxWxH)	45" x 17-1/4" x 18-1/2"

WARRANTY**5 YEARS**

Features

The 10-308 Meat Saw is considered a 'Specialty Saw', having a specific purpose unlike the other machines in the RIKON line. Designed for reliable service and efficient cutting action, it is a unique saw, indeed! Made of all metal construction, and wired for use with 3-wire 120V receptacles.

10" Meat Saw #10-308 is made for the slicing up of fresh or frozen meats into manageable sizes for storage and cooking. A favorite machine of deer hunters and other providers that require an efficient, economical way to reduce large sides of protein into smaller portions. This bandsaw features a sliding stainless steel table with two adjustable support fences for secure holding of meats during the cutting process. Adjustable ball bearing blade guides are easily set for safe operation. The rear of the saw includes a built-in meat grinder that uses standard #8 grinding plates (one plate with 4.5mm holes included). Saw is made of heavy-gauge sheet metal with stand, chip & blood tray, and safety on/off switch. Unit is not USDA or NSF certified.

Optional Accessories

- Stainless Steel Bandsaw Blade
76-3/4" x 5/8" x 4 TPI (#19-7601)
- Grinding Plates #8 (2-3/8" Diameter)
13-950 3 mm (1/8") holes
Fine Grind – For hamburger, bologna, hot dogs, beef jerky
13-952 4.5 mm (3/16") holes
Medium Grind – For hamburger, breakfast sausage, Polish & Italian sausage
13-951 6.5 mm (1/4") holes
Coarse Grind – For hamburger, summer sausage, salami, pepperoni, bratwurst
- P10-308-111 Replacement Reamer / Blade for grinder



13-952



P10-308-111



Balanced Cast Aluminum Wheels



Stainless Steel Sliding Table



Precision Guide Bearings



Sausage Link Stuffing Funnel

Accessories available on pages 17-18

RIKON

16" VS Scroll Saw



10-600VS



Optional Flex Shaft (#10-9123) installs on side of scroll saw for rotary detail work with various burs, sanding discs or drums shown with Accessory Kit (#10-9124)

Model No.

10-600VS

16" VS Scroll Saw

MOTOR

Amps	1.2
Volts	120V, 60 Hz

CUTTING CAPACITY

Blade Length	5"
Height	2"
Stroke	3/4"
Electronic Variable Speed (SPM)	550 - 1,650
Throat Depth	15-3/4"
Blade Supplied	18 TPI, Regular, Pin-less

TABLE

Size	10-1/16" x 16-5/16"
Left Tilt	0 - 45°

FEATURES

Stroke Speed Per Minute	550 - 1,650
Dust Port Diameter	1-3/8" (35 mm)
Maximum Sound Level (Idle)	<76 dB

OVERALL

Height	15"
Width	12-9/16"
Depth	24-7/8"
Base Size	9" x 15-1/2"
Net Weight	26 lbs.
Shipping Weight	30 lbs.
Shipping Carton (LxWxH)	26" x 13" x 15-1/2"

WARRANTY

5 YEARS

Features

The 10-600VS Scroll Saw is considered a 'Specialty Saw', having a specific purpose unlike the other machines in the RIKON line that are designed with large cutting capacities. The scroll saw is made for small, delicate detail cutting. Saw is made of all metal construction, and is wired for use with 3-wire 120V receptacles.

16" Variable Speed Scroll Saw #10-600VS

is designed for making small, intricate curved cuts in thinner woods that are used in making decorative scroll work, puzzles, inlays, and craft items. The thin, working blade allows the material being cut to be freely turned in tight arcs, unlike any other power saw. The DC motor provides variable operating speeds, so adjusting the blade's cutting action to different materials is easily done with just a twist of the dial. The saw's 16" throat and large machined aluminum table give extra access and stability when sawing large stock. Table also tilts to -45° for making angled cuts. Machine uses 5" long pinned or plain end blades. Includes cast iron base for greater stability, work light, pair of pin-less blade holders and one pin-less wood blade. High-speed flex shaft (available separately) attaches to the motor shaft for rotary work.

Optional Accessories

- Rotary Flex Shaft (#10-9123)
- Pin-less Blade Holder - 1 pc (#P10-600VS-96)
- 64 Piece Rotary Accessory Kit (#10-9124)

64 Piece Accessory Kit includes a variety of abrasive stones, wheels, diamond burs, twist drills, sanding drums and polishing buffs for producing excellent results in all your detail work. Appropriate collect and arbors are supplied to hold the 1/8" diameter shank accessories. With handy plastic storage case. For use with 10-9123 Flex-Shaft or other similar flex shafts and moto-tools.



Table Tilts 0° to 45°



Safety ON/OFF Switch and Variable Speed Knob



Accepts Plain and Pin End Blades



Connections for Flex Shaft

Accessories available on pages 17-18

RIKON

10" Contractors Saw

**10-201****Model No.****10-201**

10" Table Saw

MOTOR

Horsepower	1-1/2 HP
Amps	13/6.5
Volts	120 / 240V, 60 Hz
RPM	3,450

CUTTING CAPACITY

Maximum Depth of Cut at 90°	3-3/8"
Maximum Depth of Cut at 45°	2-1/4"
Max. Rip to Right of Blade	30"
Max. Rip to Left of Blade	20"
Table in Front of Blade	12-1/2"
Maximum Width of Dado	13/16"

BLADE

Diameter	10"
Arbor	5/8"
Speed	3,450
Tilt	Left
Supplied on Machine	40T, ATB, Carbide

TABLE

Size	27" x 40"
Miter Gauge 'T' Slot	(2) 3/4" x 3/8"
Height from Floor	33-1/2"
Table Size without Wings	11-5/8" x 27"
Table Size with Wings	40" x 27"
Left Wing Dimension	13-3/4" x 27"
Right Wing Dimension	14-7/8" x 27"

OVERALL

Height	35"
Width	68"
Depth	38"
Dust Port	1 @ 4"
Net Weight	313 lbs.
Shipping Weight	322 lbs.
Shipping Carton (LxWxH)	38" x 30-1/2" x 24"

WARRANTY**5 YEARS****Features**

Considered 'the heart' of a woodworking shop, table saws are essential pieces of equipment for cutting large materials like plywood or panels; ripping or cross-cutting lumber to size; making angled cuts for joinery; cutting rabbets, dadoes or molding. These versatile machines start the construction process in most every woodworking project. So it is important to choose a quality-built machine that is sturdy, easy to use, and dependable for years of service.

10" Left Tilt Contractor Table Saw #10-201 is a no nonsense machine whose simplicity is the strength behind its popularity with home crafts people and professional workshops. Operating this table saw is straight forward – blade controls are large and easy to access, box-type rip fence sets accurately, dual table 'T' slots give great options for use of miter gauges and other jigs, blade changes are easy, blade guards and control switch with large 'off' paddle add excellent safety measures to the user, and the built-in mobile base allows moving the saw around the shop easy. Wired for use with 3-wire 120V receptacles.

Standard Features

- Powerful 1-1/2 HP, 1PH, 120 / 240V, 3,450 RPM motor
- Industrial quality, multi-ribbed flat J-belt for smooth power transfer
- Precision machined cast iron table top and wings
- Dual table 'T' slots for use with miter gauges and jigs
- Magnetic table insert removes without tools
- Clear blade guard with riving knife/splitter for extra user safety
- Heavy cast iron trunnion assembly is mounted to cabinet for easy table alignment
- Rugged steel cabinet and leg construction
- Built-in mobile base activates with simple foot pressure
- Rack and Pinion mechanism for smooth blade height adjustment
- Large blade adjustment hand wheels with locks
- Easy to read blade angle scale on cabinet front
- Box-style, quick-lock rip fence and rail system give simple setting for ripping
- Enclosed cabinet has 4" dust port for efficient dust collection
- Miter gauge with positive stops for use with 'T' or plain table slots

Optional Accessories

- Dado Table Insert
- Push Stick



Cast Iron Table Top and Wings



Steel Fence with Quick Lever Lock



Clear Blade Guard with Riving Knife/Splitter



4" Dust Port Under Cabinet



Large Blade Height and Tilt Adjustment Wheels

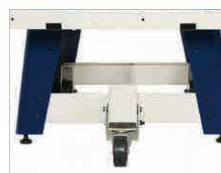

Built-In Mobile Base and Fence Storage Brackets

RIKON

10" Cabinet Saws

**11-200****11-300**

Model No.	11-200 10" Deluxe Cabinet Saw	11-300 10" Pro Cabinet Saw
MOTOR		
Horsepower	1-3/4 HP	3 HP
Amps	15 / 7.5	13
Volts	120 / 240V, 60 Hz	240V, 60 Hz
RPM	3,450	3,450
CUTTING CAPACITY		
Max. Depth of Cut 90°	3-3/8"	3-3/8"
Max. Depth of Cut 45°	2-1/4"	2-1/4"
Max. Rip Right Blade	30"	30"
Max. Rip Left Blade	13-1/2"	13-1/2"
Table Front of Blade	11-1/2"	11-1/2"
Max Width of Dado	13/16"	13/16"
BLADE		
Diameter	10"	10"
Arbor	5/8"	5/8"
Speed	3,450 RPM	3,450 RPM
Tilt	Left	Left
Supplied on Machine	40T, ATB, Carbide	40T, ATB, Carbide
TABLE		
Size	56-1/4" x 27"	56-1/4" x 27"
Miter Gauge 'T' Slot	(2) 3/4" x 3/8"	(2) 3/4" x 3/8"
Height from Floor	35-1/2"	35"
Table Size w/o Wings	10" x 27"	10" x 27"
Table Size with Wings	40" x 27"	40" x 27"
Left Wing Dimension	15-3/4" x 27"	15-3/4" x 27"
Right Wing Dimension	17" x 27"	17" x 27"
OVERALL		
Height	42"	41"
Width	64-1/4"	64-1/4"
Depth	42"	42"
Dust Port	1 @ 4"	1 @ 4"
Net Weight	355 lbs.	425 lbs.
Shipping Weight	417 lbs.	489 lbs.
Shipping Carton (LxWxH)	35" x 30" x 43"	35" x 30" x 43"
WARRANTY		
	5 YEARS	5 YEARS

Features

10" Deluxe Cabinet Saw #11-200 is a step-up from the 10-201 model, this table saw has a more powerful 1-3/4HP motor for driving blades through dense, thick timber without bogging down. The cast iron table is huge and includes 2 T-slots for use with miter gauges and a variety of sleds and jigs. A right side extension table increases the table surface for working sheet stock. The improved T-fence system glides over the machined cast iron table and securely locks in place for accurate ripping jobs. A HDFE face on the fence provides a slick, non-marring surface that makes running stock against it an effortless task. Sawing protection includes an easily changed blade guard with anti-kickback pawls and riving knife, large front paddle OFF switch, and motor protection reset function button. Large hand wheels and angle guides make adjusting and setting the blade easy. Includes 10" x 40 ATB saw blade, miter gauge, mobility kit, leveling feet, rear 4" dust collection port, push stick and wrenches. Wired for use with 3-wire 120V receptacles.

10" Pro Cabinet Saw #11-300 is the choice of a table saw for workshops. Manufactured with the same attention to detail as the 11-200 table saw, this more powerful saw has a cabinet without mobility casters for extra stability as the central workhorse in the shop. 3HP, 240V motor is up to any ripping or crosscutting job of the thickest or densest material. Where reliable power is important, the T-square fence also provides the accuracy needed for precise, dimensional cuts. Vibration is virtually eliminated with the extra weight of this saw, big motor, large machined cast iron table, trunnions and larger blade controlling hand wheels. Safety measures include a blade guard with anti-kickback pawls and riving knife, quick response front paddle OFF switch, motor protection reset function button, push stick and 4" dust port for hooking up to your dust collection system. Includes 10" x 40 ATB carbide tipped saw blade, miter gauge and wrenches. This machine has a 240V motor that requires a 3-wire electrical plug to match your electrical receptacles.

Standard Features:

- Powerful motors for years of reliable service
- Industrial quality, multi-ribbed extra wide flat J-belts for smooth power transfer
- Precision machined large cast iron table tops
- Right extension wings of laminated MDF
- Dual table 'T' slots for use with miter gauges and jigs
- Blade guards with riving knife/splitter for extra safety
- Heavy cast iron trunnion assemblies are mounted to the cabinets for easy table alignment
- Rugged all-steel cabinet construction
- Rack and Pinion mechanisms for adjusting blade height
- Extra-large blade adjustment hand wheels with locks
- Easy to read blade angle scales on cabinet fronts
- Quick-lock rip fence and rail systems give simple setting for ripping
- 4" Dust ports for efficient dust collection

Optional Accessories

- Dado Table Insert
- Push Stick



Huge Cast Iron Table Tops with Wings on Right side



Steel Fences with HDFE Faces and Quick Lever Locks



Safety Blade Guard with Riving Knife & Anti-Kickback Pawls



Onboard Storage for Fence, Miter Gauge & Wrenches



Built-in Mobile Base on #11-200 Saw

Accessories available on page 17

RIKON

Bandsaw Blades

**Regular Tooth:**

Standard blade style for general cutting of all woods and thin material. Not for resawing.

**Hook Tooth:**

Positive 10° Rake angle with deep gullets is very aggressive. Best for cutting hard, thick and difficult grained woods.

**Skip Tooth:**

0° Rake angle with flat gullet resists clogging. Best for softer woods and resawing.

**Variable Tooth:**

Varying set angles and gullet depth reduces vibration. All purpose blade for production work and cutoffs.

PART #	LENGTH	WIDTH	GAUGE	TPI	STYLE
19-6510	65"	1/2"	.025"	4TPI	Carbon Steel Skip Blade
19-7006	70-1/2"	1/8"	.018"	8 TPI	Hook Blade
19-7007	70-1/2"	1/8"	.018"	14 TPI	Hook Blade
19-7002	70-1/2"	3/16"	.025"	10 TPI	Reg Blade
19-7003	70-1/2"	1/4"	.025"	6 TPI	Hook Blade
19-7004	70-1/2"	3/8"	.025"	4 TPI	Hook Blade
19-7005	70-1/2"	1/2"	.025"	3 TPI	Hook Blade
19-7602	76-3/4"	5/8"	.0197"	4 TPI	Reg Stainless Blade
19-9310	93-1/2"	3/16"	.025"	10 TPI	Reg Blade
19-9311	93-1/2"	3/8"	.025"	4 TPI	Hook Blade
19-9312	93-1/2"	1/2"	.025"	3 TPI	Hook Blade
19-9313	93-1/2"	5/8"	.025"	3 TPI	Hook Blade
19-9910	99-3/4"	1/4"	.025"	6 TPI	Hook Blade
19-9911	99-3/4"	3/8"	.025"	4 TPI	Hook Blade
19-9912	99-3/4"	1/2"	.025"	3 TPI	Hook Blade
19-9913	99-3/4"	5/8"	.025"	3 TPI	Hook Blade
19-9914	99-3/4"	3/4"	.032"	3 TPI	Hook Blade
19-1101	111"	3/16"	.025"	10 TPI	Reg Blade
19-1100	111"	1/4"	.025"	6 TPI	Hook Blade
19-1102	111"	3/8"	.025"	4 TPI	Hook Blade
19-1103	111"	1/2"	.025"	3 TPI	Hook Blade
19-1104	111"	5/8"	.025"	3 TPI	Hook Blade
19-1105	111"	5/8"	.025"	4 TPI	Reg Blade
19-1511	111"	1/2"	.025"	14 TPI	Bi-Metal Reg Metal Cutting Blade
19-1512	111"	1/2"	.025"	18 TPI	Bi-Metal Reg Metal Cutting Blade
19-1513	111"	3/4"	.035"	8/12 TPI	Bi-Metal Var Metal Cutting Blade
19-1514	111"	3/4"	.035"	10/14 TPI	Bi-Metal Var Metal Cutting Blade

CHOOSING THE RIGHT BLADE: Blade width is measured from the back of the blade to the tips of the teeth. **For Cut-Off & Re-Sawing** use a wide, stiff blade for straight cutting. **For Contour Cutting** use a blade that is just wide enough to cut the desired curves (radius) in your work. EX: a 1/4" blade will cut a 5/8" radius; a 1/2" blade a 2-1/2"R; a 5/8" blade a 4"R.

The number of teeth per inch (TPI) will determine the ease and smoothness of cut. Use a coarse tooth blade (2, 3 TPI) for re-sawing or for thick stock. Use a fine tooth blade (4, 6 or up to 18 TPI) for general cutting of milled stock. The higher the TPI, the cut will be slower, but leave a smoother finish.

PART #	LENGTH	WIDTH	GAUGE	TPI	STYLE
19-1210	124"	1/4"	.025	6 TPI	Hook Blade All-Pro
19-1211	124"	3/8"	.025"	4 TPI	Hook Blade All-Pro
19-1212	124"	1/2"	.025"	3 TPI	Hook Blade All-Pro
19-1213	124"	5/8"	.025"	3 TPI	Hook Blade All-Pro
19-1214	124"	3/4"	.032"	3 TPI	Hook Blade All-Pro
19-1215	124"	1"	.035"	2 TPI	Hook Blade All-Pro
19-1410	142"	3/8"	.025"	4 TPI	Hook Blade
19-1411	142"	1/2"	.025"	3 TPI	Hook Blade
19-1412	142"	5/8"	.025"	3 TPI	Hook Blade
19-1413	142"	3/4"	.032"	3 TPI	Hook Blade
19-1520	142"	1/2"	.025"	14 TPI	Bi-Metal Reg Metal Cutting Blade
19-1521	142"	1/2"	.025"	18 TPI	Bi-Metal Reg Metal Cutting Blade
19-1522	142"	3/4"	.035"	8/12 TPI	Bi-Metal Var Metal Cutting Blade
19-1523	142"	3/4"	.035"	10/14 TPI	Bi-Metal Var Metal Cutting Blade
19-1701	153"	3/8"	.025"	4 TPI	Hook Blade
19-1702	153"	1/2"	.025"	3 TPI	Hook Blade
19-1703	153"	5/8"	.025"	3 TPI	Hook Blade
19-1704	153"	3/4"	.032"	3 TPI	Hook Blade
19-1705	153"	1"	.035"	2 TPI	Hook Blade
19-1801	162"	3/8"	.025"	4 TPI	Hook Blade
19-1802	162"	1/2"	.025"	3 TPI	Hook Blade
19-1803	162"	5/8"	.025"	3 TPI	Hook Blade
19-1804	162"	3/4"	.032"	3 TPI	Hook Blade
19-1805	162"	1"	.035"	2 TPI	Hook Blade
19-1601	163"	3/8"	.025"	4 TPI	Hook Blade
19-1602	163"	5/8"	.025"	3 TPI	Hook Blade
19-1603	163"	3/4"	.032"	3 TPI	Hook Blade
19-1604	163"	1"	.035"	2 TPI	Hook Blade
19-1901	176"	3/8"	.025"	4 TPI	Hook Blade
19-1902	176"	1/2"	.025"	3 TPI	Hook Blade
19-1903	176"	5/8"	.025"	3 TPI	Hook Blade
19-1904	176"	3/4"	.032"	3 TPI	Hook Blade
19-1905	176"	1"	.035"	2 TPI	Hook Blade
19-1906	176"	1-1/4"	.035"	1.3 TPI	Hook Blade

HELPFUL HINT: To prolong the life of your blades, when the bandsaw is not in use for extended periods, release the blade tension. Before reusing the bandsaw, ensure that the blade is re-tensioned and tracking is checked.



Saw Accessories



10-900



12-201



13-325, 13-345



13-900



13-912



13-952



13-951



C10-396

BANDSAW ACCESSORIES

- 10-900 Tool-less Guide Bearing Retrofit Kit for 10-324, 10-325
- 12-201 LED Work Light with Magnetic Base (See page 33)
- 13-321 Mobility Kit for 10-321
- 13-325 Mobility Kit for 10-325, 10-326
- 13-345 Mobility Kit for 10-341, 342, 345, 346, 347, 350, 350BAL, 351, 353, 370
- 13-913 Stand for 10" Bandsaw 10-305 (See pages 33 & 50)
- 13-900 Rip Fence & Rail Assembly for the 10-320, 10-321, Craftsman 32607
- C10-100 Push Stick
- 13-912 Miter Gauge for 3/4" x 3/8" (T-slot Tables Only)
- 13-920 Miter Gauge for 10-305
- 13-950 #8 Grinding Plate, 3mm (1/8") holes for 10-308
- 13-952 #8 Grinding Plate, 4.5mm (3/16") holes for 10-308 (included with saw)
- 13-951 #8 Grinding Plate, 6.5mm (1/4") holes for 10-308

BANDSAW TABLE INSERTS

- C10-372 Table Insert for 10-300 10" Bandsaw (square)
- C10-393 Table Insert for 10-305 (4-Pack)
- C10-394 Zero Clearance Inserts (4 Pack) for 10-305, 10-306, Sears 21400
- C10-395 Table Insert aluminum. All Rikon 14" & 18" Bandsaws except 10-346, 347
- C10-391 Table Inserts (4 Pack) All Rikon 14" & 18" except 10-346, 347
- C10-392 Zero Clearance Table Inserts (4 Pack) All Rikon 14" & 18" except 10-346, 10-347, 10-385
- C10-396 Table Insert for 10-346, 10-347, 10-385 (square)

BANDSAW DRIVE BELTS

- | | | | |
|---------|---|-------------|---------------------------------|
| C10-991 | Drive Belt for 10-300, 10-305 | C10-994 | Drive Belt for 10-370 |
| C10-998 | Drive Belt for 10-308 | C10-996 | Drive Belt for 10-380 |
| C10-997 | Drive Belt for 10-315 | P10-342-10 | Drive Belt for 10-342 |
| C10-995 | Drive Belt for 10-320, 321, 324, 325, 326 | C10-999 | Drive Belt for 10-341, 346, 347 |
| C10-992 | Drive Belt for 10-340, 10-345 | P10-353-F15 | Drive Belt for 10-353 |
| C10-993 | Drive Belt for 10-350, 10-350BAL, 10-351 | P10-385-B13 | Drive Belt for 10-385 |

BANDSAW GUIDE BEARINGS

- C10-108 Guide Bearings for 10-300, 10-305, 10-308 (6 Pack)
- C10-109 Guide Bearings for 10-315, 10-320, 10-321, 10-324, 10-325 (6 Pack)
- C10-144 Guide Bearings for 10-340, 10-341, 10-345, 10-370, 10-380 (10 Pack)
- C10-209 Guide Bearings for 10-350, 10-350BAL, 10-351 (10 Pack)
- C10-326 Guide Bearings for 10-326, 10-342, 10-347, 10-353, 10-385 (10 Pack)

BANDSAW TIRES

- C10-405 10" Rubber Wheel Tire for 10-300, 10-305
- C10-415 12" Rubber Wheel Tire for 10-315
- C10-421 14" Rubber Wheel Tire for 10-320, 10-321, RK14CS
- C10-425 14" Rubber Wheel Tire for 10-325, 324, 326, 350, 351, 350BAL, 353
- C10-445 18" Rubber Wheel Tire for 10-340, 10-345, 10-370
- C10-446 18" Rubber Wheel Tire for 10-341, 10-342, 10-346, 10-347
- C10-480 22" Rubber Wheel Tire for 10-380
- P10-385-9 24" Rubber Wheel Tire for 10-385

BANDSAW RETROFIT KITS

- 10-900 Tool-less Guide Bearing Retrofit Kit for 10-324, 10-325
- 10-921 6" Tall Rip Fence Extrusion and Re-Saw Bar Set for 10-325
- 10-920 Quick-Adjust 6" Tall Rip Fence System for 10-325. Includes 32-7/8" Front Rail Assembly, Anti-Drift Rip Fence Carrier, 6" Tall Rip Fence, 6" tall Re-Saw Bar, Hardware and Mounting Instructions.

SCROLL SAW ACCESSORIES

- 10-9123 Flex Shaft Attachment for 10-600VS
- 10-9124 64 PC Accessory Kit for 10-600VS

TABLE SAW ACCESSORIES

- 13-299 Dado Table Insert for 10-201, 11-200, 11-300
- C10-100 Push Stick
- 13-5011 Rip Fence for 50" Fence & Rail System 13-5012 (below), and as Replacement Fence for 11-200, 11-300 and 10-201 Table Saws
- 13-5012 Rail & Leg Assembly for 50" Fence & Rail System. Fits 11-200, 11-300 and 10-201 Table Saws. Uses 13-5011 Rip Fence (not included)



RIKON Planers 15"



23-150



23-150H

Shown with Optional Mobility Kit (23-959)

OPTIONAL ACCESSORIES

C20-915	15" Replacement HSS Knives for 23-150 (3 pack)
25-699	Carbide, 4-Edge Inserts for 23-150H (Pack of 10) 14 x 14 x 2mm
25-694	Mounting Screws for 25-699 Helical Inserts, Flat Head, T20 (Pack 10)
23-959	Mobility Kit for 23-150H, 20-106H and 20-108H

Model No.	23-150 15" Planer	23-150H 15" Planer Helical
MOTOR		
Horsepower	3 HP	3 HP
Amps	12	12
Volts	220V, 60 Hz	220V, 60 Hz
RPM	3,450	3,450
CUTTING CAPACITY		
Max. Planer Capacity	8"	8"
Max. Planer Width	15"	15"
Max. Depth of Cut	1/8"	1/8"
CUTTERHEAD		
Speed	5,000 RPM	5,000 RPM
No. of Knives/ Inserts	3 HSS Knives	72 Carbide Inserts (4 Sided)
# of Cutterhead Rows	3	4
Knife / Insert Size	15-5/32" x 1" x 1/8"	14 x 14 x 2 mm
Cuts Per Minute	15,000	20,000
Diameter	2-7/8" (72.5mm)	2-7/8" (72.5mm)
Feed Speed SF/MIN	16 and 20	16 and 20
OVERALL		
Height	48"	47"
Width	44"	44"
Depth	31-1/2"	31"
Base Size	31-1/2" x 29-3/4"	22" x 20"
Dust Port	1 @ 4"	1 @ 4"
Net Weight	450 lbs.	490 lbs.
Shipping Weight	497 lbs.	540 lbs.
Shipping Carton (L x W x H)	32-1/4" x 26-3/4" x 23-5/8"	32-1/4" x 25-3/4" x 46"
WARRANTY	5 YEARS	5 YEARS

Features

The 'Motor-On-Top' design of these 15" planers are prized by production shops because they can build permanent, long infeed and outfeed tables that are level with the non-moving planer beds. Ideal for moving lumber through the machine. Since the beds are constant while the motor and cutterhead assemblies move, setting for repeated, accurate thicknesses can be done. No adjusting of outfeed stands or tables with every changing of the cutter height. The heavy cast iron and precision machined steel construction of these planers is impressive. Very simple in design for extremely reliable service and operation. Models available with straight HSS knives or a helical cutterhead with carbide insert cutters - both will produce smooth planed surfaces. Cast iron beds are 19-15/16" long x 15-1/16" and have 4 heavy 1-7/8" diameter pillars for excellent cutterhead assembly support. Planers include 16" wide x 12" long machined cast iron bed extensions. 220V motors require 3-wire electrical plugs to match your electrical receptacles.

15" Planer #23-150 has a powerful 3HP motor driving a traditional, 3-row cutterhead with 3 High Speed Steel, single edge straight knives. Planer sits on an open, sturdy all-steel stand. Planer's cast iron base includes 4 pull-out bars for lifting and moving the machine where needed in the shop.

15" Helical Head Planer #23-150H also uses a big 3HP motor for running its 4-row helical cutterhead with 72 carbide, 4-sided insert cutters. Planer's enclosed, heavy steel base cabinet for extra support and stability. Optional mobility kit (#23-959) makes moving it easy. Just press down on the foot pedal to activate the casters.

Standard Features:

- "Motor-on-top" designs eliminate changing infeed and outfeed extensions and roller stands with every change of depth-of-cut
- Large, top hand wheel makes changing cutting depths easy
- Two feed rate speeds give best control of cutting action for milling various types of lumber
- Heavy cast iron tables give extra, rigid surfaces for planing
- Big 4 pillar supports stabilize the motor assembly to resist any flexing during use
- Locking knobs on posts secure settings for long planing runs
- Oil-bath gear boxes power the feed rollers directly from cutterheads
- Chain & sprocket drive systems provide positive stock feeding
- Spiral serrated steel infeed rollers and polyurethane outfeed rollers keep stock moving smoothly and efficiently
- Top lids give full access to cutterheads for knife or insert changes
- 4" dust ports effectively remove chips to attached dust collectors

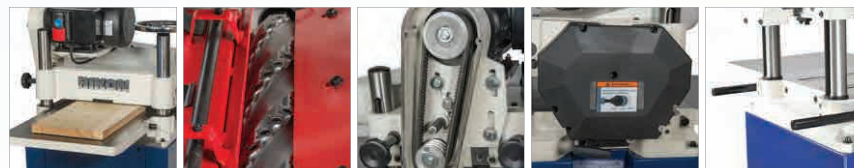

Heavy, Machined Cast Iron Infeed and Outfeed Extensions

Helical Cutterhead Design on 23-150H

Triple Drive Belt System for Constant Power to Cutterhead

Easy Access Gear Box for Changing Feed Rate Speeds

Four Handles In Base For Lifting Machines

RIKON Planers 16"



23-400/H



Shown open for easy knife changes.

OPTIONAL ACCESSORIES

25-599	Carbide 4-Edge Inserts for 23-400H, 23-530H, 25-210H, 25-010H (Pack 10) 15mm x 15mm x 2.5mm
25-594	Mounting Screws for Helical Inserts - Flat Head, T25 (Pack 10) for 25-499, 25-499C, 25-599 inserts
C20-916	16" Replacement HSS Knives for 23-400

Model No.	23-400 16" Planer	23-400H 16" Planer Helical
MOTOR		
Horsepower	3 HP	3 HP
Amps	12	12
Volts	220V, 60 Hz	220V, 60 Hz
RPM	1,400	1,400
CUTTING CAPACITY		
Max. Planer Capacity	8-13/16"	8-13/16"
Max. Planer Width	16"	16"
Max. Depth of Cut	1/8"	1/8"
CUTTERHEAD		
Speed	5,100 RPM	5,100 RPM
No. of Knives/ Inserts	3 HSS Knives	72 Carbide Inserts (4 Sided)
# of Cutterhead Rows	3	4
Knife / Insert Size	16-1/8" x 1" x 1/8"	15 x 15 x 2.5 mm
Cuts Per Minute	15,300	20,400
Diameter	2-3/4"	2-3/4"
Feed Speed SF/MIN	Variable 16 - 23	Variable 16 - 23
OVERALL		
Height	42-1/2"	42-1/2"
Width	55"	55"
Depth	24-1/4"	24-1/4"
Base Size	24-5/8" x 22-1/4"	24-5/8" x 22-1/4"
Dust Port	1 @ 4-3/4"	1 @ 4-3/4"
Net Weight	375 lbs.	375 lbs.
Shipping Weight	528 lbs.	528 lbs.
Shipping Carton (L x W x H)	32-1/4" x 29-3/4" x 48-3/4"	32-1/4" x 29-3/4" x 48-3/4"
WARRANTY	5 YEARS	5 YEARS

Features

Surfacing lumber to a specific thickness requires a machine that has plenty of power to remove a lot of material from oversized lumber, especially if the boards are wide and hardwood. RIKON's 16" planer has proven that it can handle these conditions and produce smooth surfaces that require little sanding before finishing. These dedicated planers are preferred by professional shops that deal with large volumes of lumber to mill and encounter wider planks. Available with two different cutterhead & knife designs. Each machine has a 220V motor that requires a 3-wire electrical plug to match your electrical receptacles.

16" Planer #23-400 has a traditional three knife cutterhead with High Speed Steel knives.

16" Planer #23-400H is fitted with a helical, four row cutterhead holding 72 carbide insert cutters. Each insert cutter has four, pre-sharpened sides and can be easily changed/rotated if worn or damaged. Simply loosen the retaining screw, lift up and rotate the insert to a new sharp edge and re-fasten it in place. No setting is required, as the inserts are automatically indexed and set to proper position.

Standard Features:

- 3 HP motors easily cuts 1/8" at full 16" wide capacity
- Feed rate speed is adjustable with a simple turn of a control knob
- Heavy cast iron tables give extra rigidity support for big jobs
- Planer tables adjust simply with large control handles
- Height gauges clearly indicate cut settings
- Table locks insure exact thickness settings for large planing runs
- Hinged tops lift and lock in position for clear access to the cutterhead
- Second, internal micro safety switches prevent operation when lid is up
- Top rollers aid in returning stock from the outfeed, back to the infeed side
- Infeed and outfeed table extensions provide extra support of lumber
- Dust hoods effectively remove chips when planing
- Safety on/off push button switches for extra safe machine shut downs



Roller Extensions for Extra Support

Top Stock Return Rollers & 4-3/4" Dust Port

Helical Cutterhead Design on 23-400H

Stable Cast Iron Table Supports

RIKON Combination Planer / Jointers



25-010 / H
Shown in Jointing Mode.



25-010 / H
Shown in Planing Mode.



25-210 / H
Shown in Planing Mode.



25-210 / H
Shown in Jointing Mode.

OPTIONAL ACCESSORIES

25-599	Carbide 4-Edge Inserts for 23-400H, 23-530H, 25-210H, 25-010H (Pack 10) 15mm x 15mm x 2.5mm
25-594	Mounting Screws for Helical Inserts - Flat Head, T25 (Pack 10)
C20-910	10" Replacement HSS Knives for 25-010 (3 Pack)
C20-912	12" Replacement HSS Knives for 25-200, 25-210 (3 Pack)
25-905	Mobility Kit for 25-210, 25-210H Planer/Jointer
25-910	Mobile Base for 25-010, 25-010H Planer/Jointer



25-599 Carbide Insert Cutters
Pack of 10



25-594 Mounting Screws
T25, Pack of 10



C20-910 10" HSS Knives
Pack of 3



C20-912 12" HSS Knives
Pack of 3

Model No.	25-010 10" Combo	25-010H 10" Combo Helical	25-210 12" Combo	25-210H 12" Combo Helical
MOTOR				
Horsepower	1-1/2 HP	1-1/2 HP	3 HP	3 HP
Amps	16/8	16/8	12	12
Volts	110/220V, 60 Hz	110/220V, 60 Hz	220V, 60 Hz	220V, 60 Hz
RPM	3,400	3,400	3,400	3,400
CUTTERHEAD				
Speed	4,800	4,800	4,700	5,000
Number of Knives/Inserts	3 HSS Knives	44 Carbide Inserts (4 Sided)	3 HSS Knives	56 Carbide Inserts (4 Sided)
Number of Cutterhead Rows	3	4	3	4
Cuts Per Minute	14,400	19,200	14,100	20,000
Diameter	2-1/2"	2-1/2"	2-3/4"	2-3/4"
FENCE				
Size	4-1/4" x 24-1/4"	4-1/4" x 24-1/4"	6" x 43"	6" x 43"
Tilts	0 - 45°	0 - 45°	0 - 45°	0 - 45°
Positive Stops	90° and 45°	90° and 45°	90° and 45°	90° and 45°
PLANER				
Maximum Cutting Width	10"	10"	12"	12"
Maximum Cutting Height	6"	6"	7-7/8"	7-7/8"
Wood Feed Rate	24.6 SF/MIN	24.6 SF/MIN	23 SF/MIN	23 SF/MIN
Table Size	10-1/4" x 15-3/4"	10-1/4" x 15-3/4"	21-3/8" x 12-1/16"	21-3/8" x 12-1/16"
JOINTER				
Maximum Cutting Width	10"	10"	12"	12"
Maximum Cutting Depth	1/8"	1/8"	1/8"	1/8"
Table Size	11" x 40-1/2"	11" x 40-1/2"	12-1/2" x 55-1/2"	12-1/2" x 55-1/2"
Table Height from Floor	35-1/2"	35-1/2"	33-1/2"	33-1/2"
OVERALL				
Height	37"	37"	39-1/2"	39-1/2"
Width	40-1/2"	40-1/2"	22-1/2"	22-1/2"
Depth	27"	27"	55-3/4"	55-3/4"
Base Size	22-1/2" x 22"	22-1/2" x 22"	21-1/4" x 19-1/4"	21-1/4" x 19-1/4"
Dust Port	1 @ 4"	1 @ 4"	1 @ 4"	1 @ 4"
Net Weight	147 lbs.	147 lbs.	494 lbs.	494 lbs.
Shipping Weight	166 lbs.	166 lbs.	594 lbs.	594 lbs.
Shipping Carton (LxWxH)	28-1/4" x 22-1/4" x 22-1/2"	28-1/4" x 22-1/4" x 22-1/2"	58-3/8" x 22-1/2" x 44-1/4"	58-3/8" x 22-1/2" x 44-1/4"
WARRANTY	5 YEARS	5 YEARS	5 YEARS	5 YEARS

Features

Combination machines give woodworkers the advantage of saving precious shop floor space, since they are two machines in one! The tops are precision jointers, with all of the same adjustments and settings as dedicated versions. The lower cabinets house the planers, which use the same cutterhead as the jointer, just running lumber under it instead of on top of it! Adjusting the planer tables to regulate surface cutting and final board thickness is done with large hand wheels and handles. Machines have chip capturing hoods with 4" dust ports for attaching to dust collection systems. Hoods swivel up and lock in place for the planing mode, rotate down when jointing. Conversion from one surfacing function to the other can be done in just seconds. Both sizes of machines are offered with standard straight knife cutterheads, or helical cutterheads (H) that use multiple, small insert cutters for the shearing action in surfacing stock.

10" Planer / Jointers #25-010 & #25-010H are the smallest size combination machines, but offer exceptional power and versatility that small to medium sized shops will enjoy. The 10" cutting width is suitable for much of the surfacing needs a woodworker will encounter. The #25-010 model has 3 HSS knives that have positioning pins for fast knife changes. The #25-010H machine is identical to the #25-010, but features a helical cutterhead with 44 carbide insert cutters. Each indexable insert has four pre-sharpened sides and can be easily changed/rotated if damaged or worn. Quick release jointer table locks give easy table removal for full cutterhead & knife access. Wired for use with 3-wire 120V receptacles.

12" Planer / Jointers #25-210 & #25-210H are equipped with a larger 12" cutterheads and powerful 3HP motors that make quick work in milling the hardest, or widest rough-sawn lumber. A favorite of production shops, the jointer and planer tables are made of heavy, cast iron and machined smooth for efficient movement through the cutters. Unique, one-piece jointer tables easily lift up and out of the way for planer use, or to work on the cutterhead. The #25-210 has standard cutterhead with 3 HSS straight knives. The #25-210H has a 4-row, helical cutterhead with 56 four-sided, carbide insert cutters. 220V motors require 3-wire electrical plugs to match your electrical receptacles.

Standard Features:

- All metal construction with machined table surfaces
- Large aluminum fences easily adjust 0° to 45°
- Jointer tables move for full access to cutterheads for knife changes
- Sliding safety bar adjusts over jointer knives for best user protection
- Planer tables adjust simply with large control handles
- Height / Depth gauges clearly indicate cut settings
- 4" Dust port effectively removes chips when planing or jointing
- Front on/off switches for extra safe machine shut downs



Large Adjustable Fences



Helical Cutter Heads on 'H' Models



Anti-Kickback Feature



Large Adjustable Planer Tables



Machined Steel Table Extension with Roller on #25-210/H



All Metal Cabinets with Easy Access Control Panels

RIKON

Planer 25"

**23-630H**

Positive Link Chain Drive



Massive Cast Iron Bed



Electronic Controls for Precise Settings



4-Row Helical Head Slices Through the Hardest Stock



Powerful Motors Drive Cutter Heads and Tables

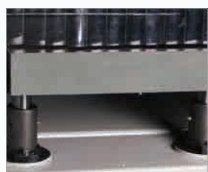

4 Column Bed Support for Extra Stability

Model No.**23-630H**

25" Planer Helical

MOTOR

Horsepower	10 HP
Amps	24
Volts	220V, 60 Hz, 3 Ph
RPM	3,400
Lifting Motor Output	1/3 HP, 1,700 RPM, 2A
Feeding Motor Output	3/4 HP, 1,700 RPM, 3A

CUTTING CAPACITY

Max. Planer Capacity	7/32" to 11-13/16"
Max. Planer Width	24-13/16"
Max. Depth of Cut	5/16"
Min Length Workpiece	11"
Table Size (L x W)	41-5/16" x 24-13/16"
Dust Port (O.D.)	6"

CUTTERHEAD

Speed SF/MIN	5,500 RPM
Number of Carbide Inserts (4-Sided)	108
Insert Size	15 x 15 x 2.5 mm
Number of Insert Rows	4
Cuts Per Minute	22,000
Cutterhead Diameter	4-3/4"
Feed Speed SF/MIN	13-52 SF/MN (Variable)

OVERALL

Height	45-1/4"
Width	47-1/2"
Depth	48"
Base Size (WxD)	47-1/2" x 48"
Net Weight	1,839 lbs.
Shipping Weight	1,960 lbs.
Shipping Carton (LxWxH)	45-11/16" x 48" x 51-1/2"

WARRANTY**5 YEARS****Optional Accessories:**

- Carbide Insert Cutters (10 Pack) #25-599
- Mounting Screws for Helical Inserts-Flathead T25 (10 Pack) for #25-599 inserts – #25-594

Features

Surfacing wide, oversized hardwood lumber to a specific thickness requires a machine that has plenty of power to remove the excess material quickly and accurately. Rikon's 25" planer features a helical cutterhead with carbide insert cutters that can handle these conditions and produce smooth surfaces that require little sanding before finishing. This hi-tech machine has two separate motors that drive the cutterhead, vary the infeed speed rate, and also lifts the table to required heights for the passing of lumber through the cutterhead. Front push button control panel makes selecting these critical settings amazingly simple and exact. No more guessing, hand cranking to adjust the table height, or taking repeated lumber measurements to confirm thicknesses settings. Massive cast iron table has 4 heavy pillars for excellent support. Top of the cabinet lifts open for easy access to the cutterhead for rotating or changing cutters. Micro-switch prevents any accidental starting of the machine when the lid is open. Top of the cabinet has a felt pad for passing lumber over the unit for repeat cuts. 220V / 3 Phase motor requires a 3-wire electrical plug to match your electrical receptacles.

25" Helical Head Planer #23-630H has a big 10HP motor running a large 4-row helical cutterhead with 108 carbide, 4-sided insert cutters. Our largest planer cuts up to a maximum 24-13/16" wide board, and thickness from 7/32" to 11-13/16".

Standard Features:

- Motor easily cuts up to 5/16" deep at full capacity
- Front panel controls planer functions with push button accuracy
- Numeric pad includes digital display read-out
- Second switch at rear of planer for extra safety shut-off
- Planer table adjusts to inch or metric thickness settings
- Variable feed rate speed of lumber gives best control of cutting action
- Heavy cast iron table gives extra rigidity and support for big jobs
- Table has heavy 4 pillar supports to resist any flexing during use
- Hinged lids give full access to cutterheads for insert changes
- Safety micro-switch prevents accidental start-ups when lid is open to access cutterhead
- Top of lid has felt pad for returning stock from the outfeed, back side to the infeed side
- Large 6" dust port effectively removes chips to an attached dust collector

RIKON

Jointers

**20-106H****20-108H**

Mobility Kit #23-959

Model No.	20-106H 6" Jointer Helical	20-108H 8" Jointer Helical
MOTOR		
Horsepower	1 HP	2 HP
Amps	12 / 6	12
Volts	110/220V, 60 Hz	220V, 60 Hz
RPM	3,450	3,450
CUTTING CAPACITY		
Max. Cutting Width	6"	8"
Max. Cutting Depth	1/8"	1/8"
Max. Rabbeting Cat	1/2"	1/2"
Table Size (L x W)	46-1/2" x 7-1/2"	73-1/2" x 9-3/8"
Table Height from Floor	32-1/2"	31-5/8"
CUTTERHEAD		
Speed	5,500	5,500
No. Inserts	28 HSS (4 sided)	40 Carbide (4 sided)
Insert Size	14 x 14 x 2mm	14 x 14 x 2mm
No. Cutterhead Rows	4	4
Cuts Per Minute	22,000	22,000
Diameter	2.44"	3"
FENCE		
Fence Size	35" x 4-7/8"	35" x 4-7/8"
Fence Tilt	-45° and 135°	-45° and 135°
OVERALL		
Length	46-1/2"	73-1/2"
Depth	28-1/2"	32"
Height	47"	46"
Base Size	18-1/4" x 14-1/2"	30" x 17-1/2"
Dust Port	1 @ 4"	1 @ 4"
Net Weight	256 lbs.	434 lbs.
Shipping Weight	289 lbs.	518 lbs.
Shipping Carton (1)	53" x 31" x 15"	81" x 23" x 15"
Shipping Carton (2)	21" x 17" x 30"	28" x 20" x 27"
WARRANTY		
	5 YEARS	5 YEARS

Features

Jointers are critical machines all woodworkers need to create the required flat surfaces on lumber for edge gluing, creating molding, ripping stock on table saws, and as the initial step for milling boards to various thicknesses with planers. RIKON offers two jointers of different width capacities that both feature helical cutterheads with carbide, 4-sided insert cutters, and solid steel base cabinets. The cutting action of the helical design with the multiple cutting edges is exceptionally smooth and efficient. The finished cut surface requiring only the lightest sanding to prepare it for finishing. Jointers have precision machined, solid cast iron tables and fences with simple, uncomplicated adjustment controls. Outfeed tables include a front rabbeting groove. The infeed table raises or lowers with a large lever handle. Fences move forward and back across the cutterhead with just a release of the rear locking lever and turning of a knob for rack & pinion positioning. Fences have stops for quick 90 degree or 45 degree angle settings. Each machine is shipped in two cartons.

6" Helical Head Jointer #20-106H has a 1HP motor driving a 4-row helical cutterhead with 28 carbide, 4-sided insert cutters. Maximum cutting width is 6". Motor is pre-wired for 110V use, but can be changed for 220V use (220V electrical plug not supplied).

8" Helical Head Jointer #20-108H has a powerful 2HP motor running a larger 4-row helical cutterhead with 40 carbide, 4-sided insert cutters. Jointer surfaces up to a maximum 8" wide board. 220V motor requires a 3-wire electrical plug to match your electrical receptacles.

Standard Features:

- Motors easily cut 1/8" depth at full width capacity
- Helical cutterhead with insert cutters cleanly shear cut leaving smooth surface results
- 4-Sided cutters are easy to rotate or change when dull or chipped
- Elevated On/Off switch gives safe, direct access to power control
- Paddle design gives quick turning of the machine 'Off'
- Heavy cast iron tables give extra rigidity and support during cuts
- Infeed tables adjust for depth of cut with convenient lever handle
- Outfeed tables include front groove for cutting rabbets up to 1/2"
- Easy to read depth of cut scale is on front of the machine
- Sturdy cast iron fences adjust quickly for setting angle cuts
- Positioning fences over the cutterhead only takes seconds
- Spring activated blade guard automatically gives cutterhead protection
- All-steel cabinet base gives solid support during jointing
- 4" dust ports effectively remove chips to attached dust collectors
- Includes push blocks, tools for assembly and changing knives

Optional Accessories:

- Carbide Insert Cutters (10 Pack) - #25-699
- Mounting Screws, T20 (10 Pack) for #25-699 inserts - #25-694
- Mobility Kit - #23-959

Helical Cutterhead with Inserts
Cuts Smooth and FastLarge Tables and Quick
Adjusting Fences

Spring Activated Blade Guards



Easy to Read Depth of Cut Scales

Conveniently Located Power
Switches with safety locks

RIKON Portable Planers & Jointer



25-130H



20-600H



25-410 STEEL STAND
(Optional) Shown with Planer # 25-130H

Note: The 20-600H Jointer can be mounted on the 25-410 Stand with the addition of a wooden/plywood top (not included)

OPTIONAL ACCESSORIES

25-499	HSS 2-Edge Inserts for 25-130H, 131, 131H Planers , 20-600H Jointer (10 Pack) 14.2mm x 14.2mm x 2mm
25-499C	Carbide 2-Edge Inserts for 25-130H, 131, 131H Planers , 20-600H Jointer (10 Pack) 14.2mm x 14.2mm x 2mm
25-498	25-130H Mounting Screws T25 (10 Pack) for inserts 25-499 and 25-499C
25-593	20-600H Mounting Screws T25 (10 Pack) for inserts 25-499 and 25-499C
25-410	Steel Stand — Height 29-1/4" • Top 23" x 14" • Base 31" x 22" for 25-130H Note: The 20-600H Jointer can be mounted on the 25-410 Stand with the addition of a wooden/plywood top (not included)

Model No.**25-130H**

13" Planer Helical

20-600H

6" Jointer Helical

MOTOR

Amps	15	10
Volts	120V, 60 Hz	120V, 60 Hz
Motor Speed (No Load)	22,000 RPM	20,000 RPM

CUTTERHEAD

Diameter	2"	2"
Speed	10,000 RPM	12,000 RPM
Number of Inserts Knives	26 HSS (2-Sided) 14.2 mm x 14.2 mm x 2 mm	12 HSS Inserts (2-Sided) 14.2 mm x 14.2 mm x 2 mm
Number of Insert/ Knife Rows	6	6
Maximum Depth of Cut	1/8"	1/8"
Maximum Cutting Width	13"	6"
Maximum Cutting Depth (Height)	6"	N/A
Minimum Length of Stock	7"	10"
Minimum Width of Stock	3/4"	3/4"
Minimum Thickness of Stock	3/16"	1/2"
Feed Speed SF/MIN	26 SF/MIN	N/A
Table Size (Length x Width)	9-1/4" x 13-1/16"	30" x 6-3/16"
Extension Table Sizes (2) (L x W)	12" x 14"	N/A Fence 19-3/4" x 4-3/8"
Dust Port (O.D.)	4" or 2-1/2" Diameter	2-1/2" Diameter

OVERALL

Height	17-5/16"	13"
Width	26-1/4"	17-1/2"
Depth	34-1/4"	30"
Base Size	13-1/4" x 22"	19" x 9-3/8"
Net Weight	73 lbs.	36 lbs.
Shipping Weight	77 lbs.	41 lbs.
Shipping Carton (LxWxH)	26" x 15-3/4" x 20-3/4"	31-1/2" x 12-1/2" x 11-1/8"

WARRANTY**5 YEARS****5 YEARS****Features**

Portable, benchtop planers and jointers are the perfect machines for surfacing lumber, whether in the workshop or on the job site. Their lighter weight and convenient size should not be dismissed – they are powerful machines that cut the hardest woods fast and leave cut surfaces ready for light sanding and finishing. Cutterhead widths are more than ample for the vast majority of work to be surfaced. Each machine is wired for use with 3-wire 120V receptacles.

13" Benchtop Planer #25-130H features a six row helical-style cutterhead and 26 HSS insert cutters. Each indexable knife insert is precision sharpened on two edges and can be easily changed/rotated if damaged or worn – just loosen, rotate, and retighten! The alternating cutter pattern in the cutterhead is super-efficient, and produces a smooth cut surface. Planer features a threaded 4-post threaded housing for extra head stability when running, side handle for quick table height adjustments, repeat cut setting lever, large fold-up extension tables, flat top for stock returning, and side carry handles.

Standard Features:

- Powerful 15 amp (2HP) motor cuts all woods efficiently
- Easy cutterhead access for changing of dull or nicked knives
- Rubber feed rollers for non-slip traction without leaving damage marks
- Planer table easily adjusts in height with large control handles
- Steel extension tables aid in stock feeding and limiting snipe
- Height / Depth gauges clearly indicate cut settings
- Efficient dust hood & dual 4" or 2-1/2" ports effectively remove chips
- Flat top for safe moving of lumber from outfeed back to infeed side
- Front located on/off switch for extra safe machine shut downs
- Sturdy 4-post design keeps motor & cutterhead assembly secure
- Includes tools and holders for adjustments and blade changes

6" Benchtop Jointer #20-600H also features a 6 row helical-style cutterhead with 12 HSS, 2-edge insert cutters for super cutting action, flat surfacing results, and easy knife changes. Features rigid, all-metal construction, machined aluminum tables, a quick depth setting mechanism with scale, adjustable fence that tilts from 90° to 45° quickly and accurately, spring-loaded safety guard, 2-1/2" dust port, front safety on/off switch and push blocks.



Helical-Style Cutterhead Gives Easy Blade Access



Front Safety ON/OFF Switch and Reset Button



4" Dust Port with 2-1/2" Adapter on 25-130H



2-Sided Insert Cutters



Helical-Style Cutterhead on 20-600



Easy Fence Tilt Controls



Fence Tilts 0° to 45°

RIKON Drill Presses 8", 12", & 13"



30-100
8"



30-212VS
12"



30-120
13"

Model No.	30-100 8" Drill Press	30-212VS 12" VS Drill Press	30-120 13" Drill Press
SPECIFICATIONS			
Type	Bench	Bench	Bench
Horsepower	1/3 HP	1/2 HP	1/2 HP
Amps	2.5	4	7.5
Volts	120V, 60 Hz	120V, 60 Hz	120V, 60 Hz
RPM	1,720	1,130	1,720
Speed Range (RPM)	620 - 3,100	160 – 3,000	220 - 3,600
Speeds	5	Variable	16
Chuck Size	1/2"	5/8"	5/8"
Chuck Taper	JT33	JT3	JT3
Drilling Capacity	1/2"	5/8"	5/8"
Spindle Travel	2"	3-1/8"	3-1/8"
Spindle Taper	JT33	MT2	MT2
Quill Diameter	1-1/2"	1-9/16" (40mm)	2-3/16"
OVERALL			
Table	6-5/8" x 6-3/8"	9-1/2" x 9-1/2"	11-3/16" (Round)
Table Tilts	90°	90°	90°
Table Rotates	360°	360°	360°
Maximum Chuck to Table	7-1/16"	13-3/16"	16-1/4"
Maximum Chuck to Base	10-1/4"	19-7/8"	24-5/8"
Column Diameter	1-7/8"	2-9/16"	2-7/8"
Height	22-3/4"	38-3/16"	42"
Base Size	11" x 7-1/8"	16" x 9-3/4"	17-3/4" x 10-1/2"
Net Weight	32 lbs.	99 lbs.	102 lbs.
Shipping Weight	36 lbs.	106 lbs.	112 lbs.
Shipping Carton (LxWxH)	18" x 9-1/4" x 13-1/4"	29-1/2" x 21-1/4" x 12"	35" x 19-1/2" x 11"
WARRANTY	5 YEARS	5 YEARS	5 YEARS

Features

Drill Presses are indispensable shop machines for boring precise, diameter holes in projects. Set up for drilling perpendicular holes in work, tables can also be tilted and locked in position for boring holes at a set angle. Utilizing the depth stop guarantees that multiple holes will all be drilled at exactly the same depth. Clamp a fence onto the table for great set-ups for repetitive borings. Induction motors drive pulleys that let you easily change drilling speeds for different drill bit sizes and materials. Large handles make table adjustments easy. Each machine is wired for use with 3-wire 120V electrical receptacles.

8" Benchtop Drill Press #30-100 is a small size machine that is popular with craftspeople and hobbyists that do not need a lot of power or capacity when drilling small holes in their projects. The small overall size and weight is also perfect for storage and transporting.

12" Variable Speed Benchtop Drill Press #30-212VS features a more powerful motor and a Vari-speed pulley system that adjusts to chuck speeds with a simple turning of a lever! Includes digital RPM readout, LED work light, laser X-Y drilling guide, clamp-friendly thin edge woodworking table and a 5/8" chuck.

13" Benchtop Drill Press #30-120 is a larger capacity, multi-step pulley model for handling bigger projects, but still in a portable benchtop design. It features a generous spindle speed setting range, a large keyed chuck for bigger diameter drills, and a round table that swivels as well as tilts.

Standard Features:

- Induction motors provide plenty of power for drilling
- Stepped pulleys give multiple spindle speed choices
- Keyed chucks hold drill bits and accessories tight
- Adjustable depth stops are great for repeatable drilling
- Cast iron head assembly for reliable service
- 3-rod, feed handles provide excellent drilling control
- Heavy cast iron bases have slots for attaching jigs or fixtures
- Machined, cast iron tables with slots for attaching clamps, vises, etc.
- Tables tilt and easily move up or down along the column for best positioning
- Thick metal columns for strong, rigid support
- Front on/off toggle switches have removable safety tabs for extra security
- Includes chuck key, holder, and speed selection chart

Optional Accessories:

- Drill Press Vises • Mortising Attachment • Work Stands



Adjustable Spindle Speeds



Keyed 3 Jaw Chucks



Cast Iron Slotted Work Tables



Heavy Cast Iron Work Bases



RIKON Drill Presses 17" & 20"



30-230
17"



30-217
17"



30-240
20"

Model No.	30-230 17" Drill Press	30-217 17" VS Drill Press	30-240 20" Drill Press
SPECIFICATIONS			
Type	Floor	Floor	Floor
Horsepower	1 HP, TEFC	1-1/2 HP, TEFC	1 HP, TEFC
Amps	13.5, 750W	13.3 / 6.7	13.5, 900W
Volts	120V, 60 Hz	115 / 230V, 60 Hz	120V, 60 Hz
RPM	1,720	1,720	1,720
Speed Range (RPM)	200 - 3,630	200 - 700 / 600 - 2,200	180 - 3,865
Speeds	16	Variable	12
Chuck Size	5/8"	5/8"	3/4"
Chuck Taper	JT3	JT3	JT3
Drilling Capacity	1"	1"	1"
Spindle Travel	3-1/8"	6"	4-3/4"
Spindle Taper	MT2	MT2	MT3
Head Rotates	360°	360°	360°
Quill Diameter	3-1/8"	2-5/8"	3"
OVERALL			
Table	13-3/4" x 13-3/4"	14" x 14"	16-1/2" x 18-3/4"
Table Tilts	90°	90°	90°
Table Rotates	360°	360°	360°
Maximum Chuck to Table	25-1/4"	27-3/4"	24-9/16"
Maximum Chuck to Base	44-13/16"	46-5/16"	43-13/16"
Column Diameter	3-1/8"	3-1/8"	3-5/8"
Height	64-3/8"	70-1/8"	68"
Base Size	17-1/2" x 22-1/2"	19-7/8" x 13-1/2"	22-3/4" x 16-1/2"
Net Weight	188 lbs.	192 lbs.	250 lbs.
Shipping Weight	198 lbs.	205 lbs.	260 lbs.
Shipping Carton (LxWxH)	55" x 21" x 9-1/2"	60" x 27-1/4" x 10-3/16"	57" x 25-1/2" x 12-1/4"
WARRANTY	5 YEARS	5 YEARS	5 YEARS

Features

These 3 Drill Presses have larger drilling capacities that handle the tough work demands of professional and industrial workshops that deal with wide panels and various sizes of furniture components. They have become the standard for shops worldwide, and will be greatly utilized and appreciated in your shop, too. As with the smaller range of drill presses, these big boys have similar design features and settings for tackling a variety of straight or angle drilling projects in wood, plastics and metals. Each machine is wired for use with 3-wire 120V electrical receptacles.

17" Floor Drill Press #30-230 is a workhorse. It has ample power to drive the largest twist drills, forstner bits, hole saws, circle cutters or other types and styles of drill bits. Adjustable, cast iron table with trough perimeter gives great support for wood and metal drilling work. 16 speed ranges produce all of the RPMs needed to match every material being bored.

17" Variable Speed Floor Drill Press #30-217 is the best in the 17" class. Designed with features that woodworkers have demanded – more powerful motor, Vari-speed pulley that adjusts the chuck speed with a simple turning of a lever – no belt changing, a digital RPM display, rotating work table with clamp-friendly thin edges, larger spindle travel, and a handy LED light.

20" Floor Drill Press #30-240 is the largest model, valued by production shops for its robust design, extra-large table, chuck, base and wide speed range. This machine gives serious, basic operation that will take the heavy workloads demanded of it.

Standard Features:

- Powerful motors provide plenty of power for drilling
- Easy-change pulley drive systems give multiple spindle speed choices
- Big capacity keyed chucks give precise drilling with small to large drill bits
- Adjustable depth stops are great for repeatable drilling
- 3-Wing feed handles provides excellent control when drilling
- Heavy cast iron bases have slots for attaching jigs or fixtures
- Machined, cast iron tables include slots for attaching clamps, vises etc.
- Tables tilt and easily move up or down along the column for best positioning
- Thick, metal columns for strong, rigid support
- Front on/off switches have removable tabs or locking options for extra security against unauthorized use.
- Includes chuck keys, holders, and speed selection charts

Optional Accessories:

- Drill Press Vises
- Mortising Attachment
- Cast Iron Tables
- LED Light with Magnetic Base



Adjustable Spindle Speeds



Digital RPM Display and Switch on #30-217



6" Spindle Travel on #30-217



Large Cast Iron Work Tables with Slots for Jigs



Accessories available on page 33

RIKON Radial Drill Presses 34"



Head moves forward and back for best positioning for drilling.



Heads tilt 45° Right and 90° left for drilling angled holes.



30-140



30-251

Optional Accessories:

- Drill Press Vises
- Mortising Attachment
- Work Tables
- Work Stands
- LED Light with Magnetic Base

See page 33

Model No.

30-140

34" Benchtop Radial Drill Press

30-251

34" Floor Radial Drill Press

SPECIFICATIONS

Type	Bench	Floor
Horsepower	1/3 HP TEFC	1/3 HP TEFC
Amps	5.5	5.5
Volts	120V, 60 Hz	120V, 60 Hz
RPM	1,720	1,720
Speed Range (RPM)	620 - 3,100	620 - 3,100
Speeds	5	5
Chuck Size	5/8"	5/8"
Chuck Taper	JT3	JT3
Drilling Capacity	5/8"	5/8"
Spindle Travel	3-1/8"	3-1/8"
Spindle Taper	MT2	MT2
Head Rotates	360°	360°
Head Tilts	45° Right, 90° Left	45° Right, 90° Left
Quill Diameter	2-3/16"	2-3/16"

OVERALL

Table	7-3/4" x 7-3/4"	11-3/16" (Round)
Table Tilts	90°	90°
Table Rotates	360°	360°
Maximum Chuck to Table	10-3/4"	28-3/8"
Maximum Chuck to Base	15-1/4"	47-3/4"
Column Diameter	2-5/16"	2-7/8"
Height	37"	64"
Base Size	13-3/4" x 8-1/2"	18" x 10-1/2"
Net Weight	84 lbs.	120 lbs.
Shipping Weight	90 lbs.	130 lbs.
Shipping Carton (LxWxH)	35" x 14" x 12-1/2"	54-1/4" x 19-1/2" x 10-1/4"

WARRANTY

5 YEARS

5 YEARS

Features

The beauty of Radial Drill Presses are the variety of angles that can be set for otherwise difficult boring operations. These specialized machines function like normal drill presses that bore in a vertical plane, but the unique, rotating head & motor upper assembly also lets the head turn laterally, left and right, for angles, too! This is ideal for boring projects that lie on the table, or are too large to do so. Situations that cabinetmakers, framers and model makers frequently get into. In addition to the adjustable head, the work tables can also be tilted and locked in position for boring holes at a set angle. Adjustable depth stops guarantee that multiple holes will all be drilled at exactly the same depth. Multi-step pulleys that let you change drilling speeds just by repositioning the drive belts. Large handles make table and head adjustments easy. Each machine is wired for use with 3-wire 120V electrical receptacles.

34" Benchtop Radial Drill Press #30-140 provides great versatility for drilling of projects that are not so large as to require a floor model. This space-saving, portable size machine has proven to be quite valuable for solving unusual drilling needs on the jobsite – from drilling balustrades for stair railings, to timber framing hole & peg construction.

34" Floor Radial Drill Press #30-251 has the same great features as the bench model, but has larger components in proportion with the added height and capacities of this floor model – larger base, column, and table assemblies. The work table on this model is round shape, and will turn 360° as well as tilt 45° in left and right.

Standard Features:

- Induction motors provide plenty of power for drilling
- Head & motor assembly tilt left & right for special angle drilling
- Stepped pulleys give multiple spindle speed choices
- Keyed chucks hold drill bits and accessories tight
- Adjustable depth stops are great for repeatable drilling
- Cast iron head with spindle assembly operates precise and smoothly
- 3 Feed handles provide excellent control when drilling
- Heavy cast iron bases have slots for attaching jigs or fixtures
- Machined, cast iron tables with slots for attaching clamps, vises etc.
- Rack & pinion design makes adjusting table and head assembly easy
- Tables tilt and move up or down along the column for best work positioning
- Thick metal columns give strong, rigid support
- Front on/off toggle switches have removable safety tabs for extra security
- Includes chuck keys, holders, and speed selection charts



5 Available Spindle Speeds



Degree Labels for Quick Setting of Head or Table Angles



Cast Iron work Tables with Slots for Jigs



Rack and Pinion Table & Head Adjustments

Accessories listed on page 33

RIKON Mortiser



34-260

Model No.

34-260

X-Y Mortiser

MOTOR

Horsepower	1/2 HP TEFC
Amps	3.6
Volts	120V, 60 Hz
RPM	1,700

SPECIFICATIONS

Type	Benchtop
Chisel Shank Diameter	1" (With 5/8" & 3/4" Bushings)
Chisel Stroke	4-3/4"
Chisel Range	1/4" to 5/8"
Chisel Sizes Included	1/4", 5/16", 3/8", 1/2"
Maximum Stock Width	3-1/2"
Maximum Stock Thickness	6-5/8"
Maximum Mortising Depth	3"
Chuck Type	Keyed
Chuck Capacity	1/2"
Table Size	7" x 5-1/8"
Table Movement Side-to-Side	6-1/2"
Table Movement Front-to-Back	3-1/4"
Fence Size	2" x 7"

OVERALL

Height	32-1/2"
Width	21-3/4"
Depth	22-1/2"
Base Size	10-3/4" x 12-1/2"
Net Weight	86 lbs.
Shipping Weight	92 lbs.
Shipping Carton (LxWxH)	26-1/2" x 17-3/4" x 13-1/2"

WARRANTY

5 YEARS

Features

How do you drill square holes? With a mortiser! This specially designed, drill press-type machine uses a drill bit housed inside of a square chisel to perform this feat. The drill bit starts boring a hole in your wood, then immediately the square chisel follows – forming the square shape, while its interior bevel forces the excess wood that is remaining in the corner sections into the spinning drill bit. The drill's flutes then carry away the cut chips up and out of the mortise. All this is done in seconds, permitting you to cut accurate mortises for furniture, cabinetry, doors, shutters and more. RIKON's Benchtop Mortiser is wired for use with 3-wire 120V electrical receptacles.

Benchtop X-Y Mortising Machine #34-260 gives precision positioning of your work for boring mortises because of the sliding, X-Y axis table. Front controls move the table either forward-and-back, or side-to-side along the dual dovetail ways. The front clamp pushes work against the cast iron rear fence, as well as acting as a hold down.

Standard Features:

- Powerful 1/2 HP motor will handle cutting the hardest wood
- Dovetail column ways give smooth vertical travel for boring
- Piston-assist feed return regulates plunge and release speed for safety
- Long, multi-position handle gives great leverage for advancing the chisels
- Keyed Chuck with guard for added safety
- Adjustable depth stop provides extra control for drilling
- Adjustable length stops keep repeat/multiple drillings consistent
- Machined table gives solid support of work pieces
- Hold down keeps work from lifting when chisels are withdrawn
- Cast iron fence adjusts forward and back for setting of drill locations
- Cast iron base, column and housing reduces vibration
- Holes in the base for mounting to a bench or stand
- Tool rest holds chisels and tools for quick access
- Housing is bored to hold 1" shanks, and includes 5/8" & 3/4" bushings
- Includes 1/4", 5/16", 3/8" and 1/2" chisels and drill bits
- Safety on/off switch with removable security tab

Optional Accessories:

- Mortising Chisels & Bits
- Work Stands



Drill Square Holes

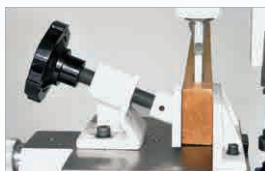

Side View of Drilling a Mortise



X-Y Table moves Left-to-Right & Front-to-Back



Convenient Front Control Handles



Protected 3-Jaw Chucks & Tool Rest Holders



Drill Press & Mortiser Accessories

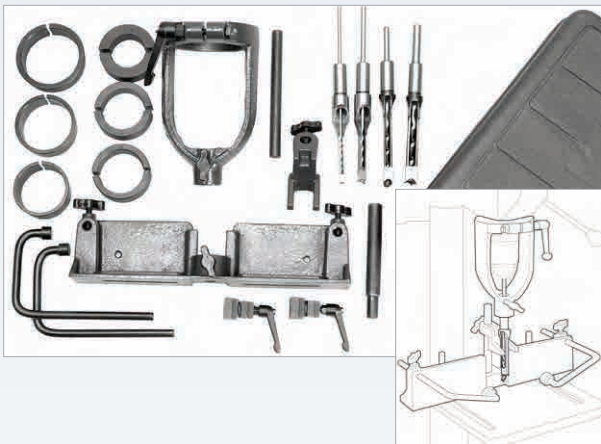

29-202 MORTISING ATTACHMENT KIT

The Mortising Attachment converts your Drill Press into an accurate mortising machine. It is ideal for drilling square holes for mortise & tenon joints that are commonly used in furniture, cabinets, sash, pattern shops and other woodworking plants.

The Mortising Attachment Kit can be installed on most any drill press quills or quill collars with a size of: 40mm, 48mm, 50.8mm, 55mm, 60mm, 66mm or 75mm diameter, by fitting different combinations of bushings in with the chisel holder/yoke.

The chisel is held in the yoke by its 5/8" diameter shank. The drill bit is held by the drill press' keyed chuck, just as a normal bit would be held. When in use, the square chisel will cut into the wood, forcing the cut material inwards. The drill bit then cuts out the center of the hole and directs the chisel cut material up out of the hole in a single motion. A square hole is the result!

Kit includes yoke, collar adapters, fence, hold downs, 4 chisels & bits (1/4", 5/16", 3/8", 1/2") and plastic storage case.

12-201 LED WORK LIGHT WITH MAGNETIC BASE

Light up your work with this powerful workshop light. LED bulb produces 500 lumens of light and the beam can be adjusted in size by focusing the magnifying lens in the head.

The flexible 18" long gooseneck bends to position the light right where you need it. The magnetic base holds firmly on any steel surface, making it versatile for mounting on machines, or anywhere in the workshop or home.

Light runs on 3 AA batteries (not included), or with the supplied USB cord and electrical outlet converter (not included). Includes a side clip with magnetic back for alternative mounting options on steel products.

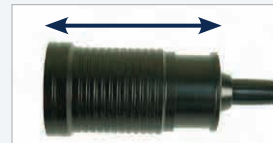

MORTISING CHISELS AND BITS

Machined steel chisels have 5/8" shanks and precision machined square outside surfaces for making accurate square holes. Drill bits that turn inside of the chisels have brad points, a single cutting edge and up-spiral flutes for rapid chip removal. Both chisel and bits require final sharpening before use.

29-914L	1/4"	Mortising Chisel & Bit
29-915L	5/16"	Mortising Chisel & Bit
29-913	3/8"	Mortising Chisel & Bit
29-912	1/2"	Mortising Chisel & Bit

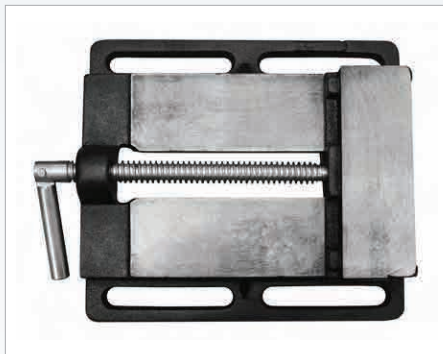

DRILL PRESS VISES

All metal construction with side slots for mounting on drill press tables. Features large toggle handles for fast adjusting of the jaws. Machined bases and jaws will maintain table flatness and give a solid support when drilling work held in the vise's jaws.

	Approx Size	Jaws L x H	Jaws Open
93-010	3" Vise	3" x 3/4"	3-1/8"
93-020	4" Vise	4" x 7/8"	4-1/4"
93-030	5" Vise	5" x 1-1/16"	5-1/8"
93-040	6" Vise	6" x 1-1/16"	6"



WORK STANDS*

Made of thick gauge steel with protective black finish, these work stands make sturdy support bases for a variety of smaller woodworking machines. To determine the right stand for your machine and work height, consult the stand dimensions – especially the stand height and top size.

	Stand Height	Top W x D	Base W x D
13-913	25"	14-1/2" x 9-3/4"	25" x 18-3/4"
52-910	28"	22-1/2" x 10-1/2"	33" x 21"
25-410	29-1/4"	23" x 14"	31" x 22"

* NOTE: Stands have tops that are open frame construction, and unless listed with a specific machine, plywood tops are usually required to be made by users to attach to the stand for supporting and mounting your machine.



METALWORKING TABLE

Cast iron Drill Press table made for metalworking drilling jobs which use cooling fluids. Table has 2 T-slots for holding jigs, channels to capture fluids, and drain hole. Measures 13-5/8" x 13-7/8" with 1-7/8" (47mm) diameter post. Included with RIKON's 30-230 drill press, also fits models 30-217, 30-236 and 30-251 or similar models.

P30-230-6A 13-5/8" x 13-7/8"

RIKON Mini & Midi Lathes



70-105



70-220VSR



70-100

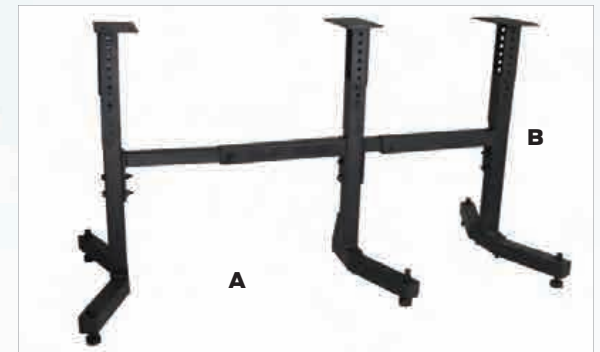

70-920 UNIVERSAL STAND FOR MINI AND MIDD LATHES (A) Rugged, all-steel stand adjusts from 23-1/4" to 37-1/4" long and 24-1/2" to 34-1/2" high to its top mounting plates. Includes anti-vibration rubber feet that will adjust to uneven floors for added stability.

70-913 STAND EXTENSION (B) Stand bolts onto the 70-920 lathe stand end to increase the stand length 18-3/4" to 32-1/4" for holding lathes with bed extensions.

Model No.**70-105**

10" x 18" Mini Lathe

70-100

12" x 16" Mini Lathe

70-220VSR

12.5" x 20" VSR Midi Lathe

MOTOR

Horsepower	1/2 HP	1/2 HP, TEFC	1 HP
Amps	3.7	5.7	6
Volts	120V, 60Hz	115V, 60 Hz	120V, 60 Hz
RPM	1,700 RPM	1,720 RPM	2,900 RPM
Direction	Forward	Forward	Forward/Reverse

SWING

Swing Over Bed	10"	12"	12-1/2"
Swing Over Tool Rest	7-1/2"	9-1/2"	9-5/8"
Working Distance Between Centers	18"	16"	20"

SPEEDS

Number of Speeds	5	6	Variable
Range RPM	500, 1,175, 1,850, 2,225, 3,200	430, 810, 1,230, 1,810, 2,670, 3,900	250-750, 550-1,650, 1,300-3,850

HEADSTOCK/TAILSTOCK

Spindle Nose Inch x TPI, RH	1" x 8	1" x 8	1" x 8
Headstock Taper	MT2	MT2	MT2
Tailstock Taper	MT2	MT2	MT2
Tailstock RAM Travel	1-3/4"	2-1/2"	3-1/2"
Indexing Positions	0	12	24
Tool Rest Post Diameter	5/8"	5/8"	1"

OVERALL

Length	35-1/2"	32"	40-3/4"
Width	10-1/2"	10-1/2"	12"
Height	14-3/4"	17-1/2"	17-5/8"
Base Size	29-1/2" x 7-3/8"	27-3/4" x 7-3/4"	37-1/4" x 7-3/4"
Net Weight	74 lbs.	89 lbs.	115 lbs.
Shipping Weight	80 lbs.	92 lbs.	124 lbs.
Shipping Carton (LxWxH)	21-7/8" x 15-3/4" x 18-5/16"	33-3/4" x 12" x 11-1/2"	39" x 20-1/2" x 12-3/4"

WARRANTY**5 YEARS****5 YEARS****5 YEARS****Features**

These small size lathes are excellent machines for beginners, occasional wood turners, and professionals that do not require large diameter or long length capacities for their turning work. Thoughtfully designed and solidly constructed of cast iron with precision machined parts. These lathes are capable to turn bowls up to 12-1/2" diameter, 20" spindles or as long as needed just by adding one or more bed extensions to the lathe bed end. From turning pens to platters, these small lathes are used and appreciated by every level of wood turner for their simplicity and versatility. Lathes are wired for use with 3-wire 120V electrical receptacles.

10" x 18" Mini Lathe #70-105 was designed specifically at the request of pen turners who wanted a sturdy, dedicated machine for their craft. This basic mini lathe is constructed of cast iron so vibration is not a factor, unlike other lathes made of aluminum. 5 Speed ranges cover the bases for boring barrel holes, roughing out pen billets, turning to shape and finishing. Includes spur center, live center, 6" tool rest, knock-out bar, and wrenches.

12" x 16" Mini Lathe #70-100 is a perennial favorite of beginning turners because of its simple design, but also for the sturdy construction that will last for years of reliable use. Six speed settings and indexing head give all of the RPM ranges needed for roughing billets, turning to final shape and then finishing projects on the machine. Headstock pulley guard tilts open for easy belt changes. Spindle rotates forward, only. Includes spur center, live center, 3" faceplate, 6" tool rest, knock-out bar, and wrenches.

12-1/2" x 20" Variable Speed Midi Lathe #70-220VSR is basically a scaled down, portable version of larger, free-standing lathes using tools rests with 1" diameter posts. Designed and constructed heavier than the mini lathe for added stability, this newly designed machine has features requested by professionals - a more powerful 1HP motor, electronic variable speed controls, wider range of operating speeds, digital RPM readout, forward/reverse drive, index settings, and larger diameter and spindle length turning capacity. Includes spur center, live center, 3" faceplate, 8" tool rest, knock-out bar, wrenches and tool holder.

Standard Features:

- Powerful motors provide ample power for all turning needs
- Ball-bearing construction for smooth, precise spindle operation
- Heavy cast iron beds, headstocks and tailstocks reduce vibration
- Machined beds and matching components give precise alignment
- Adjustable locking handles keep components positioned securely
- Easy access to headstock and base for drive belt changes on pulleys
- Tail stocks self-eject live centers so knock-out bars are not needed
- Lathe beds have machined ends for adding extensions
- On/Off switches have removable safety tabs for extra security

Optional Accessories:

- Lathe Bed Extensions • Lathe Stand and Stand Extension
- Tool Rests, Face Plates, Spur Centers & Chucks



Easy Belt Changes & Spindle Indexing



Ample RAM Travel with Ball Bearing Live Centers



Machined End for Bed Extensions



Convenient Control Locations



Accessories available on pages 38-39

RIKON Heavy-Duty Lathes



70-305
70-306



70-450

BADGER Safety Spur Center 70-940



The only lathe drive center with a safety guard! The unique spring-loaded guard prevents accidental contact with the spurs with turning chisels or the tool rest. Also protects loose clothing, hair, jewelry, etc. from becoming entangled with the spurs. Features a spring-loaded center point with 3/8" of travel. This allows easy loading, unloading, reversing end-for-end, or stopping the work piece for inspection while the lathe is in motion. Fits all lathes with MT2 tapers. Use on spindles down to 1/2" diameter.



Model No.	70-305 16" x 42" VSR Lathe	70-306 16" x 42" VSR Lathe	70-450 20" x 37" VSR Lathe
MOTOR			
Horsepower	1-1/2 HP, 1 Ph, TEFC	1-1/2 HP, 1 PH, TEFC	1-1/2 HP, 1 Ph, TEFC
Amps	4.7	4.7	7
Volts	220V, 60 Hz	110V, 60 Hz	230V, 60 Hz
RPM	1,725 RPM	1,725 RPM	1,400 RPM
Direction	Forward/Reverse	Forward/Reverse	Forward/Reverse
SWING			
Swing Over Bed	16"	16"	20"
Swing Over Tool Rest	12"	12"	18"
Working Distance Between Centers	42"	42"	37"
SPEEDS			
Electronic Variable Speeds	0 - 3,200	0 - 3,200	50 - 3,850
Range RPM	0-1,200, 0-3,200	0-1,200, 0-3,200	50-380, 70-530, 120-900, 200-1,450, 350-2,750, 460-3,850
HEADSTOCK/TAILSTOCK			
Spindle Nose Inch x TPI, RH	1-1/4" x 8	1-1/4" x 8	1-1/4" x 8
Headstock Taper	MT2	MT2	MT2
Tailstock Taper	MT2	MT2	MT2
Tailstock RAM Travel	4"	4"	4"
Indexing Positions	12 (36 Possible)	12 (36 Possible)	24
Tool Rest Post Diameter	1"	1"	1"
OVERALL			
Length	77"	77"	64-1/2"
Width	22"	22"	21-1/2"
Height	47-1/4"	47-1/4"	50"
Net Weight	386 lbs.	386 lbs.	461 lbs.
Shipping Weight	440 lbs.	440 lbs.	626 lbs.
Shipping Carton (LxWxH)	61" x 18" x 23"	61" x 18" x 23"	68-1/4" x 23-1/2" x 50-1/4"
WARRANTY			
	5 YEARS	5 YEARS	5 YEARS

Features

RIKON's Professional Lathes are all solidly constructed of heavy cast iron and steel components to reduce vibration that can develop when turning large diameter bowls, platters, or spindles/columns. For ultimate control, these machines feature Electronic Variable Speed controls for easy dialing in of spindle speeds while turning, so you get the best cutting or finishing speeds for your work. Reversible spindle direction, 4" Ram travel, 1-1/4" spindle size and the overall large dimensions of the lathes are designed to take the rigors of transforming big materials into finish turned classic pieces. Each lathe motor requires a 3-wire electrical plug to match your electrical receptacles.

16" x 42" Variable Speed Lathes #70-305 & #70-306

Headstocks contain all the controls for easy access when changes are needed – spindle speeds, rotation direction, indexing and powering on/off. Heads rotate and lock in place in 6 positions for changing from turning over the bed, to the outboard end for large diameter faceplate or chuck work. Cast iron stands have brackets for adding a lower shelf for tools or sand bags for extra anti-vibration weight. Digital controls on headstock for best access when turning. Includes 12" tool rest. NOTE: 70-305 and 70-306 differ in motors only.

20" x 37" Variable Speed Lathe #70-450 offers the largest bowl and spindle capacities of the professional lathes. Headstock swivels for outboard turning, and bed frame is pre-bored for attaching an outboard tool rest assembly (available separately). Digital controls can be moved to 4 bed locations for best access when turning. Cast iron stand has 2 brackets for adding shelves. Includes 6" and 12" tool rests.

Standard Features:

- Powerful motors provide great, reliable power
- All ball-bearing construction for smooth, precise spindle operation
- Electronic variable speed control provides easy changing of working speeds
- Digital RPM read-out gives true operating spindle speed
- Forward/Reverse spindle rotation gives great finishing options
- Heavy cast iron beds, headstocks, tailstocks and tool rests reduce vibration
- Machined beds and matching components give precise alignment
- Adjustable cam-locking handles keep tool rest base and tailstock securely positioned
- Spindles' multiple Indexing positions allow extra details to be accurately applied to work
- Easy access to headstock and base for drive belt changes on pulleys
- Tail stocks self-eject live centers so knock-out bars are not needed
- Includes stand, spur center, live center, faceplate, tool rest, knock-out bar, wrenches and tool holders

Optional Accessories: Lathe Bed Extensions • Tool Rests • Face Plates • Spur Centers & Chucks

Accessories available on pages 38-39



Heads Swivel for Outboard Turning

Heavy-Duty Tools Rests & Beds

Easy Access Controls & Indexing

Large 4" RAM Travel



LATHE BED EXTENSIONS

Lathe Bed Extensions are made of heavy cast iron with machined beds and ends. Extensions bolt to the right end of the lathes to extend their working spindle length capacity. Finished RIKON blue color.

70-906	24" Bed Extension, for 70-105
70-900B	24" Bed Extension for 70-100
70-901	24" Bed Extension for 70-220VSR



70-935 3-1/2" TAILSTOCK FOR 70-220VSR MIDI LATHES

Made specifically to upgrade 70-220VSR Midi Lathes made before 2017 that have tailstocks with shorter 2-1/2" RAM travel. Tailstock now has a longer 3-1/2" RAM travel that provides extra reach when supporting spindles, plates or bowls. Especially useful when holding a drill chuck to bore pen blanks, or drill center holes for deep bowl turning. Includes all parts for installing onto the lathe bed for use.



MULTI-V DRIVE BELTS

70-995	Neoprene Drive Belt for 70-050, 70-050VS, 70-100
70-996	Rubber Drive Belt for 70-050, 70-050VS, 70-100
70-997	Rubber Drive Belt for 70-220VSR
70-994	Neoprene Drive Belt for 70-300, 70-305
70-999	Rubber Drive Belt for 70-425, 70-450
70-998	Rubber Drive Belt for 70-500
P70-105-24	Rubber Drive Belt for 70-105



70-920 LATHE STAND

(A) Supports mini and midi lathe styles. All-steel construction, the Stand adjusts from 23-1/4" to 3"-1/4" long, and 24-1/2" to 34-1/2" working height. Includes anti-vibration rubber feet that will adjust to uneven floors for added safety.

70-913 LATHE STAND EXTENSION

(B) Bolts onto the #70-920 and former #70-910 stands to support lathes with attached lathe bed extensions. This Stand Extension adjusts from 18-3/4" to 32-1/4" long, and 24-1/2" to 34-1/2" working height. Includes rubber feet.



TOOL RESTS

70-924	4" Tool Rest with 5/8" Post
70-926	6" Tool Rest with 5/8" Post
70-928	8" Tool Rest with 5/8" Post
70-914	4" Tool Rest with 1" Post
70-916	6" Tool Rest with 1" Post
70-918	8" Tool Rest with 1" Post
70-912	12" Tool Rest with 1" Post
70-9158	Tool Rest Adapter Bushing 1" OD / 5/8" ID



FACE PLATES

70-933	3" Face Plate 1 x 8 TPI
70-934	3-3/8" Face Plate 1-1/4" x 8 TPI
70-936	6" Face Plate 1 x 8 TPI
70-992	Nylon Spindle Washer for face plates & chucks 1-3/64" ID x 1-5/8" OD
70-990	Nylon Spindle Washer for face plates & chucks 1-3/8" ID x 1-3/4" OD



CENTERS – WITH MT2 TAPERS

70-943	Spur Center 3-1/16" long
70-944	Spur Center 2-11/16" long
70-945	Live Center 4-1/2" long
70-946	Live Center 4-1/4" long (with permanent center point)
70-947	Center Point for 70-944
70-948	Center Point for 70-943, 70-945
30-991	5/8" Keyed Drill Chuck and Arbor



BADGER Safety Spur Center 70-940



The only lathe drive center with a safety guard! The unique spring-loaded guard prevents accidental contact with the spurs with turning chisels or the tool rest. Also protects loose clothing, hair, jewelry, etc. from becoming entangled with the spurs. Features a spring-loaded center point with 3/8" of travel. This allows easy loading, unloading, reversing end-for-end, or stopping the work piece for inspection while the lathe is in motion. Fits all lathes with MT2 tapers. Use on spindles down to 1/2" diameter.



RIKON Woodturning & Carving

SC3 Geared Scroll Chuck is a compact lathe chuck that is ideal for use on small to medium sized machines, giving good access to turning smaller work pieces. Its reduced weight also reduces loads on headstock bearings. Chuck's large jaw slides offer unrivalled strength and holding power, and accepts the full range of work holding jaw accessories in Record's line. Precision machined to exacting standards for unsurpassed accuracy. SC3 Package includes pre-threaded Chuck, 50mm Jaw Set, Woodworm Screw, Chuck Key, 2" Faceplate, Mounting Screws and handy storage case.

SC4 Professional Geared Scroll Chuck is perfect for the demanding woodturner working larger pieces on lathes with 14" and larger swing. This larger sized chuck is made to the same exacting standards as the SC3 model, and includes an enclosed back with full indexing plate, and long ball end hex key for easy jaw adjustments. Comes without threaded spindle insert (available separately), so multiple inserts can be used to mount the chuck on different lathes. SC4 Package includes Chuck body, 50mm Jaw Set, Woodworm Screw, Chuck Key, Mounting Screws and handy storage case. Requires purchase of threaded insert.

78-062	SC3 Chuck Package for 1" x 8 TPI Spindles
78-064	SC3 Chuck Package for 3/4" x 16 TPI Spindles
78-065	SC3 Chuck Package for M33 x 3.5 TPI Spindles
78-066	SC4 Chuck Package with 2" Faceplate (no insert)
78-103	SC4 Chuck Package (no insert)
78-106	SC4 Chuck, body only with 8 jaw screws (no key, jaws or insert)

For more Jaws, Faceplates, & Chuck Accessories visit www.rikontools.com

77-001 Carving Tool Set (12 Piece with DVD)

This unique woodcarving package of 12 tools, instructional DVD and booklet for woodworkers of all skill levels from the novice to professional. Carving tools are made from spring alloy steel that maintains a keen sharp edge and has excellent corrosion resistance. Ergonomically shaped wooden handles with steel ferrules secure the blades' long tangs for extra strength required for hand and mallet work. Set includes educational DVD and Booklet instructing the use and techniques of the 12 carving tools by a carving-by-numbers process that teaches the 'Significant Six' techniques that will form a solid foundation of skills for successful woodcarving. The tool sharpening process, timber selection and working tips is covered, plus, 15 design projects are also included with the set. Tools include: chisel, skew chisel, V-tool and 9 gouges of varying sweeps and sizes.



Threaded Inserts

Full range of different threads is listed on www.rikontools.com

78-128	3/4" x 16 TPI UNF RH
78-125	M33 x 3.5 TPI RH ISO
78-133	1" x 8 TPI UNC RH
78-159	1" x 8 TPI RH & LH Dual
78-162	1-1/4" x 8 TPI UNS RH
78-132	1-1/4" x 8 TPI UNS RH for DVR-XP & 1624-44 lathes
78-126	3/4" Plain Bore
78-134	5/8" Plain Bore



77-003 Carving Mallet

Made of close grained, solid beech provides the ideal 15 ounce weight and hardness for delicate work as well as heavier roughing outs.

77-002 Carver's Vise

Extremely versatile and flexible to position work for carving. Cast iron construction with pivoting support arm, mounting plate, and clamp for attaching to benches.

RIKON Woodturning System



70-800 4-Piece Woodturning Tool System with Carbide Insert Cutters

Developed for the experienced or novice wood turner, RIKON's turning set features tungsten carbide cutters that keep their sharp cutting edges longer than typical carbon or high speed steel tools. After hours and hours of use, if a cutter becomes dull, just rotate it to work with another new side of the edge. Changes only take seconds.

Set includes a 16" long, machined aluminum Handle with an anti-vibration grip that features a unique forward chucking system. Simply unscrew the knurled chuck collet to insert any of the three supplied shafts with carbide cutters, tighten the chuck collar, and you are ready to turn! No tools are required!

Three, 8-3/8" steel Shafts are supplied with either a Circle, Square or Diamond shaped carbide Insert Cutter secured to their end with a T20 screw. The finely machined shafts have bottoms that are milled with a flat, and 2 side bevels for extra stability on the tool rest when turning. The bottom flat is in line with the cutter to maintain the cutter in a flat position for scrape cutting. The two side

bevel surfaces also give the user extra support when the cutter is shifted to an angled skew position for shear cutting action. Flats give the support and control needed, especially when turning bowl interiors where the cutter is extended out far from the tool rest.

Set includes: 16" Handle, 3 Shafts with either a Circle, Square or Diamond carbide cutter, a T20 wrench, all packaged in a presentation storage box.



Circle Cutter

Very effective for finishing cuts on bowl interiors or any cove or contoured design on spindles.



Square Cutter

Straight edges on this carbide cutter make it extremely useful for shaping convex or straight surfaces. Ideal for producing tenons for furniture construction.



Diamond Cutter

Mainly used to add thin line details on turnings, the spear-point tip is great for undercutting and making small beads on projects. The long sides of the triangular shape are also useful for fine shaping of rims on bowls or plates.

OPTIONAL ACCESSORIES

70-801	16" Handle only	70-812	Diamond Carbide Insert Cutter
70-805	Shaft only (without cutter)	70-802	6" Handle Extension
70-810	Round Carbide Insert Cutter	70-803	Handle Counterweight
70-811	Square Carbide Insert Cutter	70-804	Side Handle

- The machined handle is hollow with a removable end cap. If a longer handle is desired, a separate 6" Handle Extension is available that screws into the rear of the handle, then re-install the end cap.
- If extra weight in the handle is desired to counteract turning vibration and jerks, an optional solid steel Counterweight fits inside of the handle and is secured in place by the end cap.
- The handle's chuck also has a threaded side hole to install a Side Handle for extra holding stability when outboard turning of large bowls or platters.

RIKON Wet Grinder & Buffers



82-100



81-608



81-600



81-910
Adjustable Workstand



Top view of 1/2" wide slots for mounting machine



Adjustable Workstand secures buffers and grinders in place and at the right height for buffing, sharpening or shaping projects. 2" diameter steel column adjusts from 28" to 36" and includes a plastic storage fixture for holding extra wheels or tools. Steel top has 6 pre-formed slots for attaching machines. Heavy cast iron tripod base has holes for bolting down to shop floors for best stability.

(Not recommended for 82-100 Sharpener).

Model No.	82-100 8" Wet Sharpener	81-600 6" Buffer	81-608 8" Long Shaft Buffer
MOTOR			
Horsepower	1/4 HP	3/4 HP	1/2 HP
Amps	1.6	4.8	2.5
Volts	120V, 60 Hz	120V, 60 Hz	120V, 60 Hz
Speed (No Load)	1,750 RPM / Stone 115 RPM	3,450 RPM	1,750 RPM
WHEEL			
Diameter	8"	6"	8"
Width	Stone 1-9/16" / Strop 1-1/8"	1/2"	1/2"
Arbor	12 mm	1/2"	17 mm (11/16")
Arbor Length	3-5/8"	3-5/8"	5-1/2"
Grits	220 and leather strop	N/A	N/A
OVERALL			
Length	17"	18"	22-1/2"
Width	10"	7-3/4"	7-3/4"
Height	12"	8-3/8"	9-1/2"
Base Size	11-1/2" x 10"	7-3/4" x 7-3/4"	8-3/4" x 7-3/4"
Cord	6 ft.	6 ft.	6 ft.
Net Weight	23 lbs.	22 lbs.	23 lbs.
Shipping Weight	26 lbs.	23.5 lbs.	26 lbs.
Shipping Carton (L xW xH)	15-1/8" x 14-9/16" x 14-1/8"	19-3/4" x 8-5/8" x 9-7/8"	24-3/4" x 8-3/4" x 9-5/8"
WARRANTY	2 YEARS	2 YEARS	2 YEARS

Features

RIKON introduces three machines that every shop can use for sharpening and polishing jobs. The Wet Sharpener is ideal for putting a precision edge on hand tools blades. Its slow rotation eliminates any chance of ruining edges from overheating. The Buffer are very versatile. With different grades of applied compounds, the wheels can put a quick, final honed edge on tools, or buff a high gloss shine on woods, metals and other materials. Useful on shop tools, household items, machinery or vehicle parts, sports equipment, and so on. Machines are wired for use with 3-wire 120V electrical receptacles.

8" Wet Sharpener #82-100 provides woodworkers with a system that efficiently removes steel and sharpens tool edges without any overheating that can ruin blades, thanks to the slow turning abrasive wheel and water cooling action. A holding jig makes putting the right cutting angle on tools easy and consistent, every time. Leather strop removes any burrs and puts the final razor sharp, final honed edge on tools – chisels, plane blades, turning & carving tools, knives, axes and more.

Standard Features:

- 1/4 HP motor with forward and reverse rotation
- Steel support bar repositions for horizontal or vertical use with jigs
- Jig holds tools & slides along the bar for solid, consistent support
- 220 grit abrasive wheel will put precision edges on tools
- Large, removable water tray for easy refilling and clean-up
- Rugged plastic cabinet keeps motor safe from moisture
- Leather honing wheel for final edge sharpening and honing
- Protected switch with Forward/OFF/Reverse positions
- Includes angle measuring tool, support arm, straight tools edge holding jig and honing compound.

6" Buffer #81-600 & 8" Buffer #81-608 for polishing surfaces of woods, metals, plastics, hardware, rocks, jewelry and more! Excellent for maintaining sharp edges on chisels & blades, putting buffed finishes on wood turnings, or just keeping other shop hand tools and home furnishings in tip-top, rust free, polished condition.

Standard Features:

- Motors have lifetime lubricated ball bearings for care-free use
- Dynamically balanced arbor provides for smooth operation
- Extended shafts allow extra space for moving work around the wheels for polishing
- Threaded shafts will accommodate buffs up to 1-1/4" wide
- Heavy cast iron bases give extra support and vibration resistance
- Bases have two 7/16" holes for mounting on benches or stands
- Spiral sewn cotton wheels for buffing flat and low curved surfaces
- Safety on/off switch for extra protection for unauthorized use

Optional Accessories:

- 81-910 Workstand (see page 40)
(Not recommended for the 82-100)



RIKON 8" Bench Grinders



80-805



80-808



80-800VS

OPTIONAL ACCESSORIES

80-910	Adjustable Work Stand for Grinders & Buffers, Adjusts 28" – 36" (See page 40)
80-899	Steel Wheel Flange for Low Speed Grinder 80-805
80-901	2.5x Magnifying Eye Shield Lens Kit for 80-805
80-902	Left Hand FLAT Tool Rest for 80-805 & 80-808
P80-805-4	Cast Wheel Flange for Low Speed Grinder 80-808
P80-808-4	LED Light Bulb for 80-808
P80-805-49	60 Grit 8" AlOx White Grinding Wheel
P80-805-5	120 Grit 8" AlOx White Grinding Wheel
P80-805-54	Diamond Faced Grinding Wheel Dresser
P80-800VS-85	Steel Wheel Grinding Wheel Dresser
P80-800VS-70	60 Grit 8" Vitrified AlOx Gray Grinding Wheel
P80-800VS-37	8" Wire Wheel for 80-800VS
P80-800VS-84	LED Light Bulb for 80-800VS

Model No.	80-805 1/2 HP 8" Bench Grinder	80-808 1 HP 8" Bench Grinder	80-800VS 3/4 HP 8" VS Bench Grinder
MOTOR			
Horsepower	1/2 HP	1 HP	3/4 HP
Amps	3	7	5
Volts	120V, 60 Hz	120V, 60 Hz	120V, 60 Hz
Speed (No Load)	1,750 RPM	1,750 RPM	2,000 - 3,400 RPM
WHEEL			
Diameter	8"	8"	8"
Width	1"	1"	1"
Arbor	5/8"	5/8"	5/8"
Grits	60 and 120	60 and 120	60 and Wire
OVERALL			
Length	16-3/8"	10-1/4"	17"
Width	10-3/4"	19"	14"
Height	11-1/4"	12-1/8"	17"
Base Size	7-5/8" x 5-1/2"	9-1/2" x 6-3/4"	9" x 6-3/4"
Cord	6 ft.	6 ft.	6 ft.
Net Weight	34.2 lbs.	54 lbs.	39 lbs.
Shipping Weight	37.5 lbs.	59 lbs.	42 lbs.
Shipping Carton (LxWxH)	16-1/2" x 14-5/8" x 11-1/2"	24" x 15-3/8" x 14"	21-5/8" x 14" x 11-7/8"
WARRANTY	5 YEARS	5 YEARS	2 YEARS

Features

Sharpening tools or general grinding work is made a bit easier and more exact with RIKON's low speed 1,750 RPM and variable speed bench grinders, where other grinders operate at only a high 3,450 RPM! Lower speeds mean that metal being removed can be controlled better, and reduces heat build-up and 'bluing' of a cutting edge being sharpened – ruining the hardness and temper of the tool. Bench grinders are available in three horsepower levels, each are wired for use with 3-wire 120V electrical receptacles.

1/2 HP Low Speed Bench Grinder #80-805 has more than enough power for small workshops and for carpenters, turners, carvers and other craftspeople working with hand tools. Its left tool rest includes a groove in its design for the sharpening of drill bits. Wheel flanges are stamped. Grinder includes a diamond wheel sharpener.

1 HP Low Speed Bench Grinder #80-808 is a larger size motor and will tackle the tough grinding jobs that are typical in production shops, as well as the finesse shaping and sharpening of hand tools. Tool rests on this machine are extra-large and flat, without a drill bit sharpening groove. Wheel flanges are cast metal. Grinder includes 1-1/4" O.D. dual dust collection ports on the rear of the wheel guards, and a second pair of eye shields with 2.5x magnification for close-up inspection of your edges being ground.

3/4 HP Variable Speed Bench Grinder #80-800VS is made for the metalworking trades, but is extremely useful in workshops for handling general metal cleaning, shaping, grinding and sharpening jobs. A great all-around companion to RIKON's low speed grinders that are set up and used mainly for sharpening woodworking tools. The VS Grinder features a front dial that easily controls the motor speed from 2,000 to 3,400 RPM, so that you can correctly set the wheel speeds to the different materials being worked on. The grinder's wire wheel will remove rust, paint or grime from metal surfaces, and the 60 grit grinding wheel is for tough metal removal and shaping. Includes a pull-out water tray, powerful LED light on a flexible gooseneck, grinding wheel dresser and wrenches.



Large Metal Tool Rests



Safety-Eye Shields



Abrasive Wheel on 80-800VS



Variable Speed Dial and Water Tray on 800-VS



2.5x Magnifying Eye Shields on #80-808



LED Work Lights



Dual 1-1/4" Dust Ports on #80-808



Wire Wheel on 80-800VS

Standard Features:

- Cast iron bases with rubber feet reduce vibration
- Holes in the base for mounting to a bench or stand
- Metal wheel guards for added protection
- Adjustable cast metal tool rests give solid tool support
- Adjustable safety eye shields give added protection
- Adjustable spark shields keep users safe from hot sparks
- Aluminum oxide grinding wheels give excellent cutting action
- 60 Grit abrasive wheel for rough grinding and metal removal
- 120 Grit abrasive wheel for final sharpening or shaping
- Wire wheel for removing surface rust, paint, or grime
- Safety on/off switch with removable security tab

Accessories available on page 42

RIKON Belt & Disc Sanders



50-144



50-112



50-161VS



50-151

Model No.	50-151	50-161VS	50-112	50-144
	1" x 30" Belt / 5" Disc	1" x 30" Belt / 6" Disc	4" x 36" Belt / 6" Disc	1" x 42" Belt / 8" Disc
MOTOR				
Horsepower	1/3 HP	3/4 HP	1/2 HP	5/8 HP
Amps	2.3	4	4.3	5.8
Volts	120V, 60 Hz	120V, 60 Hz	120V, 60 Hz	120V, 60 Hz
BELT				
Size	1" x 30"	1" x 30"	4" x 36"	1" x 42"
Speed	3,270 SFPM	1,909 - 3,248 SFPM	1,900 SFPM	3,000 SFPM
DISC				
Diameter	5" PSA	6" PSA	6" PSA	8" PSA
Speed	3,450 RPM	2,000 - 3,400 RPM	3,450 RPM	1,725 RPM
TABLE				
Belt Table Size	5-3/4" diameter	5-3/4" diameter	4-3/4" x 1"	10" x 4"
Disc Table Size	7-1/4" x 3-3/4"	8" x 5-5/16"	9" x 6-1/4"	7-1/4" x 6"
Tables Tilt	0° - 45°	0° - 45°	0° - 45° (Disc Only)	0° - 45°
Miter Gauge	Included	Included	Included	Included
Miter Gauge Slot	7/16" x 1/4"	5/8" x 1/4"	5/8" x 3/8"	7/16" x 3/16"
OVERALL				
Height	14-5/8"	16-3/4"	11"	19-1/2"
Width	15"	20-1/2"	21"	14-1/2"
Depth	12-5/8"	12"	10"	26"
Base Size	8-1/4" x 6"	9-1/4" x 6-3/4"	15-1/4" x 6-5/8"	18-5/16" x 11"
Dust Port	2 @ 1-3/4" O.D., 1-1/2" ID	1 @ 1-3/4" O.D., 1-1/2" ID 1 @ 1-1/2" O.D., 1-1/4" ID	1 @ 2-1/2" O.D., 2-1/4" ID	1 @ 1-3/4" O.D., 1-1/2" ID 1 @ 2" O.D., 1-3/4" ID
Net Weight	15.5 lbs.	30.2 lbs.	38.5 lbs.	59 lbs.
Shipping Weight	19.5 lbs.	32.6 lbs.	43 lbs.	63 lbs.
Shipping Carton (LxWxH)	17-1/2" x 12-1/4" x 11-1/2"	18-3/4" x 16-3/8" x 12-5/8"	22" x 11-1/2" x 12"	20-1/4" x 13-1/4" x 15-1/2"
WARRANTY	5 YEARS	5 YEARS	5 YEARS	5 YEARS

Features

Belt & Disc Sanders are ideal combination machines for tackling a variety of surfacing and shaping needs on projects. Taking up little space in your shop, these portable sanders can be easily stored away when not in use. Their rotating Discs use easy-to-apply pressure sensitive adhesive backed (PSA) sandpaper, and with their work tables offer great control for touching up board ends, rounding off corners, or sanding small parts. The Belts provide similar sanding functions as the discs, with some additional advantages. The 1" wide belts surface only smaller materials, but their rear support platens can be removed to allow flexing of the belts for working curved and deep areas on projects. The bigger 4" belts run on wide frames and are best for sanding larger board faces and edges. 1" belt and disc tables adjust for sanding angles and have slots for use with miter gauges. Sanders are wired for use with 3-wire 120V electrical receptacles.

1" x 30" Belt / 5" Disc Sander #50-151 is great for working on small craft projects – home decorations, jewelry, toys, doll furniture, repair work and more. The machine's small motor is very efficient in driving the belt and disc, so stock removal goes quickly. Recommended for light-duty use.

1" x 30" Belt / 6" Disc Sander #50-161VS is the 'big brother' to the 50-151 Sander. Enhanced features include a more powerful motor with variable speeds for dialing in the best sanding speeds for your work material, larger 6" sanding disc, work table and overall machine size. Refer to the chart for specifications.

1" x 42" Belt / 8" Disc Sander #50-144 is a more powerful combination machine for larger surfacing projects. Its scaled-up design with cast iron frame and tables are made for heavier duty work. Large handles make adjusting table angles easy.

4" x 36" Belt / 6" Disc Sander #50-112 is the preferred style of machine where the majority of sanding would be done on the wide abrasive belt. Belt frame adjusts in any position from horizontal to vertical to meet your sanding needs. The belt's support fence can be removed for full access to the whole length of the belt, and with the sanding disc positioned below the belt, it will not interfere with belt sanding of wide projects that overhang the frame. Machine features heavy cast iron base, and quick release belt lever.

Standard Features:

- Induction motors provide plenty of power for sanding
- Spring loaded tension automatically keep belts at best operating level
- Tracking knobs allow correct positioning of belts on frames
- Work tables adjust 0° to 45° for sanding angles
- On/Off switches have removable safety tabs for extra security
- Includes miter gauges



Cast Tables Tilt 0° - 45°



Easy Access Belt Tracking



Variable Speed Sanding Feature
on Model #50-161VS



Quick Release Belt Tension Handle
On Model #50-112



Dust Hoods and Ports for Efficient Dust
Removal with Attached Dust Collectors

RIKON Belt & Disc Sanders



50-120

Shown with Optional Stand 52-910



50-122

Includes Work Stand.

Model No.**50-120**

6" x 48" Belt / 10" Disc

50-122

6" x 48" Belt / 10" Disc

MOTOR

Horsepower

3/4 HP

1 HP

Amps

10

8

Volts

110V, 60 Hz

120V, 60 Hz

BELT

Size

6" x 48"

6" x 48"

Speed

2,030 SFPM

1,836 SFPM

Tilt

0° - 90°

0° - 90°

DISC

Diameter

10" PSA

10" PSA

Speed

1,720 RPM

2,510 RPM

TABLE

Belt Table Size

7-7/8" x 4-3/4"

8-3/16" x 2-1/8"

Disc Table Size

4" x 8"

6-5/8" x 13"

Disc Table Tilts

0° - 45°

0° - 45°

Miter Gauge

Included

Included

Miter Gauge 'T' Slot

3/4" x 3/8"

1/4" x 5/8"

OVERALL

Height

16"

41-1/2" (On Stand)

Width

28-1/4"

22"

Depth

17-1/4"

31-1/2"

Base Size

22" x 10-1/4"

23-1/4" x 16-7/8" (Stand Base)

Dust Port

1 @ 2-1/2"

1 @ 2"

Net Weight

92 lbs.

86.6 lbs.

Shipping Weight

102 lbs.

94 lbs.

Shipping Carton (LxWxH)

28-1/4" x 16" x 17-1/4"

29-3/4" x 18" x 18-3/8"

WARRANTY**5 YEARS****5 YEARS****Features**

Large size sanders are the standard in production shops for their increased sanding belt and disc sizes that are needed for the most efficient sanding of projects – big or small. They are equally appreciated by every level of woodworker for the same reasons. Best to have a larger machine to do your work, than a smaller unit that will struggle to try to do the same. Combination sanders give the best of both worlds, sanding on a belt for wide surface work, or with a disc for edge shaping and finishing. Sanders are wired for use with 3-wire 120V electrical receptacles.

6" x 48" Belt / 10" Disc Sander #50-120 is a larger, more robust version of the #50-112 sander (see pages 36 & 37), where the majority of sanding would be done on the wide abrasive belt. Belt frame adjusts in any position from horizontal to vertical to meet your sanding needs. The belt's support fence can be removed for full access to the whole length of the belt, and with the sanding disc positioned below the belt surface, it will not interfere with belt sanding of wide projects that overhang the frame. The large 10" diameter disc is very useful for edge work. Machine features heavy cast iron base, quick release belt lever, cast iron tilting table and miter gauge.

6" x 48" Belt / 10" Disc Sander with Stand #50-122 offers woodworkers the same belt and disc sizes and operating features as the #50-120, but, has a more powerful motor, re-designed base of sturdy, heavy gauge sheet steel, higher positioned disc location, cast aluminum disc table with patented rack & pinion table angle-setting handle system, and it includes a steel stand.

Standard Features:

- Powerful induction motors provide plenty of power for sanding
- Frames and bases all made of sturdy metal for extra rigidity
- Spring loaded tension automatically keep belts at best operating level
- Belts' tracking knobs allow correct positioning of belts on frames
- PSA sandpaper discs apply quickly to their metal disc plates for instant use.
- Work tables adjust 0° to 45° with large locking handles for sanding angles
- Dust Hoods and ports for efficient dust removal with attached dust collectors
- On/Off switches have removable safety tabs for extra security

Optional Accessories:

- Sanding Belts
- Sanding Discs
- Work Stands



Belt Tilts 0° - 90° Use in Vertical or Horizontal Positions



Cast Tables Tilt 0° - 45°



Quick Release Belt Tension Handles



Work Support Table for Belt Use



Large 10" Diameter Sanding Discs



Convenient Carrying Handles

Accessories available on page 50

RIKON Disc & Spindle Sanders



51-200



51-202



50-300

Model No.	51-200 12" Disc	51-202 12" Disc	50-300 4-1/2" Spindle
MOTOR			
Horsepower	1/2 HP	1-1/4 HP	1/2 HP
Amps	6	8	3.4
Volts	120V, 60 Hz	120V, 60 Hz	110V, 60 Hz
SPINDLE			
Length	N/A	N/A	4-1/2"
Diameter	N/A	N/A	1/2" to 3"
Oscillation	N/A	N/A	15/16"
Oscillation Per Minute	N/A	N/A	29 OPM
DISC			
Diameter	12" PSA	12" PSA	N/A
Speed	1,720 RPM	1,750 RPM	1,700 RPM
TABLE			
Size	17-1/8" x 6-1/2"	16-3/8" x 6-7/8"	14-3/4" x 14-3/4"
Table Tilt	45° Up and Down	30° Up and 45° Down	0° to 45° Forward
Miter	Included	Included	N/A
Miter Gauge Slot	3/4" x 3/8"	3/4" x 3/8"	N/A
OVERALL			
Height	16"	15-1/2"	23-1/2"
Width	19"	17-1/2"	17-1/4"
Depth	16-1/4"	19-1/2"	14-3/4"
Base Size	12-5/8" x 11"	12-3/4" x 10"	11-13/16" x 11"
Dust Port	2-1/2" O.D. or 2-1/4" I.D.	2" O.D. or 1-13/16" I.D.	2" O.D. or 1-3/4" I.D.
Net Weight	62 lbs.	68 lbs.	76 lbs.
Shipping Weight	72 lbs.	73 lbs.	80 lbs.
Shipping Carton (LxWxH)	21" x 18" x 17-1/4"	18-1/2" x 17-3/4" x 16-3/8"	17" x 17" x 20-5/8"
WARRANTY	5 YEARS	5 YEARS	5 YEARS

Features

Specialty sanders are becoming increasingly popular with workshops that frequently have projects requiring edge sanding of a variety of dimensions and curves. For dependability, size range and versatility, having the following machines dedicated to sanding will speed up production set-ups, work times and capabilities. The 12" Disc Sanders provide ample sanding surfaces for larger size work and are often used to level bottoms of turned bowls, plates and urns. The Spindle Sander is a wizard in sanding inside and outside curves and arcs on toys, furniture details, decorations and a variety of craft projects. Curves are everywhere! The Spindle Sander takes 4-1/2" long spindles from 1/2" to 3" diameters and includes a cast iron table that tilts forward 45* for smoothing angled cuts from the bandsaw. Sanders are wired for use with 3-wire 120V electrical receptacles.

12" Benchtop Disc Sander #51-200 is a dedicated disc sander of generous proportions that professional shops favor for fitting and finishing operations. Direct drive motor provides exceptional power, and makes sanding fast and efficient. Cast iron construction with balanced metal disc plate reduces vibration and gives accurate sanding results. Top brake pad for quick stopping of the disc. Cast iron table has rack & pinion adjustment with detents (0, 22.5, 45 degrees) for fast angle setting, and has a 'T' slot for use with a miter gauge.

12" Benchtop Disc Sander #51-202 is a more powerful variation of the #51-200 Sander with some design changes. The new cast aluminum table with 'T' slot is easily tilted with standard dual locking lever handles using the scaled trunnions. The dust collection system now includes a 2" O.D. dust port with an 18" long hose and 2-1/4" O.D. fittings for fast connections to dust collectors. Both 12" sanders now include a safety guard on the disc.

4-1/2" Benchtop Spindle Sander #50-300 makes sanding contoured edges a fast and easy operation, and make possible the smoothing of interior edge surfaces of bored holes! Great for preparing decorations, toys and furniture parts for finishing. Sander comes with 5 spindle diameters from 1/2" to 2", and will take up to a 3" diameter (available separately). Spindles are of machined steel with rubber bodies that expand to secure sanding sleeves in place. Spindles simply screw into the motorized base for use for rotating at 1,700 RPM, with a 15/16" up-down stroke at 29 times per minute. Precision machined table includes 6 plastic inserts for sanding at straight 90° or for angled table settings. Large side knob and two locking levers to keep the table secure. Rear 2" O.D. dust port attaches to collectors for efficient dust removal. Sander's steel base includes two handy side holders to store spindles and inserts. Front safety power switch has convenient paddle OFF design with rear hole for using a lock to prevent unauthorized use.

Optional Accessories:

- Sanding Discs (PSA)
- Sanding Sleeves
- Sanding Spindles
- Work Stands



Cast Tables Tilt to 45°
Rack and Pinion Table Adjustment
on Model #51-200



Manual Disc Brake on Models
#51-200 and #51-202



18" Long Dust Hose with 2-1/2" OD/
2" ID Fittings on Model #51-202



Model #50-300 Includes
5 Spindles and 6 Table Inserts



Table Tilts to 45° Forward
on Model #50-300

Accessories available on page 50

RIKON Sanding Accessories



SANDER BELTS

50-9080	1" x 30" Belt 80 Grit (Pack 10)
50-9120	1" x 30" Belt 120 Grit (Pack 10)
50-9150	1" x 30" Belt 150 Grit (Pack 10)
50-9180	1" x 30" Belt 180 Grit (Pack 10)
50-9220	1" x 30" Belt 220 Grit (Pack 10)
50-9999	1" x 30" Belt Assortment 2 each – 80, 120, 150, 180, 220 (Pack 10)
<hr/>	
50-3080	1"X42" Belt 80 Grit (Pack 5)
50-3120	1"X42" Belt 120 Grit (Pack 5)
50-3150	1"X42" Belt 150 Grit (Pack 5)
50-3180	1"X42" Belt 180 Grit (Pack 5)
50-3220	1"X42" Belt 220 Grit (Pack 5)
50-3320	1"X42" Belt 320 Grit (Pack 5)
50-3999	1"X42" Belt Assortment 2 each – 80, 120, 150, 180, 220 (Pack 10)
<hr/>	
50-4080	4" x 36" Belt 80 grit (Pack 2)
50-4120	4" x 36" Belt 120 grit (Pack 2)
50-4150	4" x 36" Belt 150 grit (Pack 2)
50-4180	4" x 36" Belt 180 grit (Pack 2)
50-4220	4" x 36" Belt 220 grit (Pack 2)
50-4999	4" x 36" Belt Assortment 2 each – 80, 150, 220 (Pack 6)
<hr/>	
50-6080	6" x 48" Belt 80 grit (Pack 2)
50-6120	6" x 48" Belt 120 grit (Pack 2)
50-6150	6" x 48" Belt 150 grit (Pack 2)
50-6180	6" x 48" Belt 180 grit (Pack 2)
50-6220	6" x 48" Belt 220 grit (Pack 2)
50-6999	6" x 48" Belt Assortment 2 each – 80, 150, 220 (Pack 6)

NOTE

See page 2 for information on your local RIKON Distributor or how to contact RIKON for ordering parts.

Visit the RIKON website at www.rikontools.com to view the accessories listed, for a for additional information about our machines, and to download a manual or parts list.



SANDING DISCS

50-5080	5" Disc 80 Grit PSA (Pack 5)
50-5120	5" Disc 120 Grit PSA (Pack 5)
50-5150	5" Disc 150 Grit PSA (Pack 5)
50-5180	5" Disc 180 Grit PSA (Pack 5)
50-5220	5" Disc 220 Grit PSA (Pack 5)
50-5999	5" Disc Assortment 2 each – 80, 120, 150, 180, 220 (Pack 10)
<hr/>	
50-6080D	6" Disc 80 Grit PSA (Pack 2)
50-6120D	6" Disc 120 Grit PSA (Pack 2)
50-6150D	6" Disc 150 Grit PSA (Pack 2)
50-6180D	6" Disc 180 Grit PSA (Pack 2)
50-6220D	6" Disc 220 Grit PSA (Pack 2)
50-6999D	6" Disc Assortment 2 each – 80, 150, 220 (Pack 6)
<hr/>	
50-8060	8" Disc 60 Grit PSA (Pack 5)
50-8080	8" Disc 80 Grit PSA (Pack 5)
50-8120	8" Disc 120 Grit PSA (Pack 5)
50-8180	8" Disc 180 Grit PSA (Pack 5)
50-8220	8" Disc 220 Grit PSA (Pack 5)
50-8999	8" Disc Assortment 2 each – 80, 120, 150, 180, 220 (Pack 10)
<hr/>	
50-10060	10" Disc 60 Grit PSA (Pack 2)
50-10080	10" Disc 80 Grit PSA (Pack 2)
50-10120	10" Disc 120 Grit PSA (Pack 2)
50-10180	10" Disc 180 Grit PSA (Pack 2)
50-10220	10" Disc 220 Grit PSA (Pack 2)
50-10999	10" Disc Assortment 2 each – 80, 150, 220 (Pack 6)
<hr/>	
50-12060	12" Disc 60 Grit PSA (Pack 2)
50-12080	12" Disc 80 Grit PSA (Pack 2)
50-12120	12" Disc 120 Grit PSA (Pack 2)
50-12180	12" Disc 180 Grit PSA (Pack 2)
50-12220	12" Disc 220 Grit PSA (Pack 2)
50-12999	12" Disc Assortment 2 each – 80, 150, 220 (Pack 6)



SANDING SLEEVES

50-45060	60 grit – diameters 1/2", 3/4", 1", 1-1/2", 2" (Pack of 5)
50-45100	100 grit – diameters 1/2", 3/4", 1", 1-1/2", 2" (Pack of 5)
50-45150	150 grit – diameters 1/2", 3/4", 1", 1-1/2", 2" (Pack of 5)
50-45303	60, 100, 150 grits – 3" diameter (Pack of 3)

SPINDLES

4-1/2" long, includes arbor with rubber body, 2 flanges and nut for use on the 50-300 Oscillating Spindle Sander.

50-3012	1/2" Diameter for 50-300
50-3034	3/4" Diameter for 50-300
50-3001	1" Diameter for 50-300
50-3112	1-1/2" Diameter for 50-300
50-3002	2" Diameter for 50-300
50-3003	3" Diameter for 50-300



WORK STANDS

13-913	25" STAND – Top: 14-1/2" x 9-3/4" • Base: 25" x 18-3/4"
52-910	28" STAND – Top: 22-1/2" x 10-1/2" • Base: 33" x 21"
25-410	29-1/4" STAND – Top: 23" x 14" • Base: 31" x 22" * NOTE: Stands have tops that are open frame construction, and unless listed with a specific machine, plywood tops are usually required to be made by users to attach to the stand for supporting and mounting your machine.
80-910	PEDESTAL STAND – See page 40 Adjusts: 28" – 36" • Top: 12-3/8" x 9-3/4"

RIKON Dust Collectors



Features

Collecting Dust and the chips that have been produced from the cutting, surfacing, sanding and boring of wood and other materials MUST be recovered for personal health safety, workplace safety, to lengthen machine life and the quality of their output. Whether working in a small or large shop, the use of dust collectors will enhance all aspects of the woodworking process. The choice of the right size of collector will depend on the type of machine(s) they will be hooked up to, and their frequency of use.

1.35 HP Dust Extractor #63-100 is a small canister-type vacuum system with a 12 gallon capacity, and plenty of power. Easily portable from machine to machine with its top carry handle. Includes convenient top on/off switch, 4" x 10' hose, hose clamps, filter cartridge, and replacement paper filters. For dry use only (not for vacuuming up water or other liquids). Wired for use with 3-wire 120V receptacles.

Optional Accessories

- Filter Cartridges – #63-915
- Paper Filter Bags (5 pack) – #63-920
- Mobility Kit – #63-900

1 HP Dust Collector #60-105 is a small size machine that is extremely versatile for workshops. It delivers powerful 660 CFM of suction that will efficiently vacuum up all your wood chips and dust; has lockable casters for easy moving between machines; has a mounting bracket for wall hanging option; and features a special 9" x 4-3/4" intake funnel system that when attached will adjust up to 55" high for lathe or other high area vacuum needs. Includes a 9 foot x 4" diameter hose, hose clamps, 2-micron cloth filter bag, carry handle and safety on/off switch. Dual voltage motor is wired for 115V use, but can be changed for 230V use (230 plug not provided).

Optional Accessories

- Cloth Dust Filter Bags (2 Micron) – #60-903

Model No.	63-100	60-105
	1.35 HP	1 HP
SPECIFICATIONS		
Air Flow	106 CFM	600 CFM
Motor	1.35 HP, 1,000 Watts	1 HP
Amps	6	7.5 / 3.75
Volts	120V, 60 Hz	115V / 230V, 60 Hz
FILTRATION		
Blower Diameter	5"	9"
Blower Material	Steel	Steel
Micron	0.5 Micron	2 Micron
FEATURES		
Canister Size	12 Gallons	2.4 CU/FT Bag
Hose Connection	1 @ 4"	1 @ 4"
Sound Level	<95 dB	<78 dB

	63-100	60-105
	1.35 HP	1 HP
OVERALL		
Height	25-3/8"	19"
Diameter	14-3/4"	14-1/2"W x 18"D
Net Weight	22 lbs.	48 lbs.
Shipping Weight	24 lbs.	56 lbs.
Shipping Carton	16-1/2" x 16-1/2" x 26"	20" x 17" x 22"
WARRANTY	5 YEARS	5 YEARS



63-915 Filter Cartridge



63-920 Paper Filter Bags (5 Pack)



63-900 Mobility Kit



60-903 Cloth Filter Bag (2 Micron)

RIKON Dust Collectors



60-100



60-150



60-200

Shown with Optional Dust Canister / Cartridge 60-905

OPTIONAL DUST CANISTER / CARTRIDGE with PLEATED FILTER

Available for all 3 Dust Collector models

Model No.**60-100**
1 HP**60-150**
1.5 HP**60-200**
2 HP**SPECIFICATIONS**

Cubic Feet Per Minute	640 CFM	1,192 CFM	1,157 CFM
Motor	1 HP	1-1/2 HP	2 HP
Amps	7	10.4/5.2	16
Volts	115V, 60 Hz	115V / 230V, 60 Hz	115V, 60 Hz
Motor Speed	3,450	3,400	3,450
Blower Wheel Diameter	9"	10"	12"
Blower Wheel Material	Steel	Steel	Steel
Sound Rating @ 3 Feet	<78 dB	<84.3 dB	<78 db
Bag Filtration	5 Microns	5 Microns	5 Microns
Bag Diameter	14-3/4"	20"	20"
Bag Capacity	2.1 Cubic Feet	5.4 Cubic Feet	5.4 Cubic Feet
Bag Length	26"	33"	33"
Hose Connection	1 @ 4"	1 @ 5", 2 @ 4"	1 @ 5", 2 @ 4"

OVERALL

Length	32-1/4"	37"	37"
Width	15"	22"	22"
Height	60"	76-1/2"	76-1/2"
Net Weight	60 lbs.	84 lbs.	92 lbs.
Shipping Weight	68 lbs.	94 lbs.	102 lbs.
Shipping Carton (L xWxH)	30" x 18" x 18-1/4"	36" x 22-3/4" x 22-3/4"	36" x 22-3/4" x 22-3/4"

WARRANTY**5 YEARS****5 YEARS****5 YEARS****Features**

Collecting Dust and the chips that have been produced from the cutting, surfacing, sanding and boring of wood and other materials MUST be recovered for personal health safety, workplace safety, to lengthen machine life and the quality of their output. Whether working in a small or large shop, the use of dust collectors will enhance all aspects of the woodworking process. The choice of the right size of collector will depend on the type of machine(s) they will be hooked up to, and their frequency of use.

1 HP Dust Collector #60-100 is a great size for use in a small shop. Single 4" dust port draws 640 CFM, more than enough vacuum power for big chip makers, like jointers and planers. Built-in casters and handle make moving it about easy. Includes top cloth filter bag, lower disposable plastic chip bag, quick-release band clamps, and safety on/off switch. Collector is wired for use with 3-wire 120V receptacles.

Optional Accessories for 1 HP

- Plastic Disposable Chip Bags (5 Pack) – #60-901
- Cloth Filter Bag and Plastic Chip Bag Set (2 Pack) – #60-918
- Metal Dust Canisters with Pleated Cartridge Filters – #60-900

1.5 HP Dust Collector #60-150 offers increased 1,192 CFM vacuum power for use with larger machinery, and has a single 5" dust port with dual 4" dust intake fitting for use with two operating machines at one time. All metal construction with casters for mobility. Includes top cloth filter bag, lower disposable plastic chip bag, quick-release band clamps, one 4" inlet cap, and safety on/off switch. Motor is 115/230V, and is wired for use with 3-wire 120V receptacles.

2 HP Dust Collector #60-200 develops the greatest 1,250 CFM of suction. Offers the same features as the #60-150 machine, but with a more powerful 2HP motor. Collector is wired for use with 3-wire 120V receptacles.

Optional Accessories for 1.5 HP & 2 HP

- Plastic Disposable Chip Bags (5 pack) – #60-902
- Cloth Filter Bag and Plastic Chip Bag Set (2 Pack) – #60-928
- Metal Dust Canisters with Pleated Cartridge Filters – #60-905



Powerful motors with easy access on/off switches



4" Dust Port inlets for attaching to single or multiple machines



Casters for easy mobility



Plastic Disposable Dust Bags (5 Pack)

- 60-901 for – 1HP
- 60-902 for – 1.5 & 2 HP



Cloth Filter Bag and Plastic Chip Bag Set (2 Pack)

- 60-918 for – 1HP
- 60-928 for – 1.5 & 2 HP



Metal Filter Canister/ Cartridge

- 60-900 for – 1HP
- 60-905 for – 1.5 & 2 HP

RIKON Air Filtration



62-400



62-100



Both Models Include Remote Controls



Rear view - Easy changing of outer and inner filters on both models

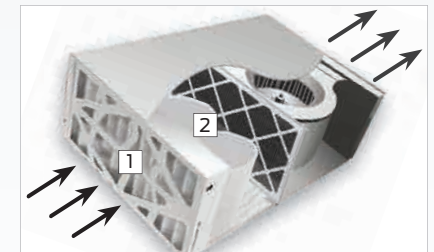

2 Stage Air Filtration System

Model No.

62-400

1/6 HP Air Cleaner

62-100

1/4 HP Air Cleaner

SPECIFICATIONS

Cubic Feet Per Minute	400 CFM	950 CFM
Motor	1/6 HP	1/4 HP
Amps	1	6
Volts	120V, 60 Hz	115V, 60 Hz
Speeds	300, 350 or 400 CFM	480, 750, or 950 CFM
Cabinet	20 Gauge Steel	20 Gauge Steel
Blower Wheel Type	Steel	Steel
Blower Type	Squirrel Cage	Squirrel Cage
Sound Rating on High	<50 - 60 dB	<74 dB
Filter Size	9-1/2" x 16-1/2" x 1"	12" x 24" x 1"
Filter (Microns)	Outer 5, Inner 1	Outer 5, Inner 1
Timer	1, 2 or 4 Hour Segments	2, 4, or 8 Hour Segments
Room Size - Per Hour	20' x 20' x 8' - 7 Times Per Hour	20' x 20' x 8' - 14 Times Per Hour

OVERALL

Length	20-1/4"	30-1/2"
Width	17-1/4"	25-1/2"
Height	10-1/4"	12-1/4"
Net Weight	31 lbs.	66 lbs.
Shipping Weight	34 lbs.	79 lbs.
Shipping Carton (LxWxH)	23-3/4" x 19-3/4" x 13-1/2"	33-1/2" x 26" x 14-1/4"

WARRANTY

5 YEARS

5 YEARS

Features

Having clean, breathable air in the shop is normally a difficult feat with the running machinery constantly creating fine saw dust. Dust collectors can only do so much to solve this air quality problem, so the use of an air filtration system is needed. These air movement systems use disposable and re-usable filters to screen out the floating dust particles in the air – as small as 1 micron in size! Hang the air filters from the ceiling or well-located shelf, and they can scrub up to a 20' x 20' x 8' room clean 7 to 14 times an hour. For small or larger shops, this means that clean air is doable for maintaining a healthy and safe work environment. Both models are wired for use with 3-wire 120V electrical receptacles.

1/4 HP Air Filtration System #62-100 creates the most air flow with speed settings of 480, 750 or 950 CFM, which will clean a 20' x 20' x 8' shop 14 times per hour. For larger shops, or those which are creating excessive dust, the use of two of these systems is recommended.

1/6 HP Air Filtration System #62-400 is very effective for smaller sized shops with its air flows of 300, 350 or 400 CFM. For large rooms up to 20' x 20' x 8' with average dust creation from work, this unit will circulate and clean the air 7 times per hour. Unit includes fuse overload protection.

Standard Features:

- Sturdy 20 gauge steel cabinet construction
- Three speed settings
- Three timer settings
- Settings via push buttons or remote control
- Quick release latches for easy filter changes
- Replaceable inner and outer filters
- Eye bolts for hanging from shop ceilings



Operates with Push Button Controls or with Remote



Includes Eye Bolts for Ceiling Mounting



Tool-less Latches for quick Filter Changes



62-901F Outer Pleated Filter (5 micron) Filter for 62-400



62-902F Inner Filter Bag (1 Micron) Filter for 62-400

Filters for the following Air Filtration Systems

- 62-100
- 60-200
- 61-750



61-911F Outer Filter (5 Micron)



61-910C Outer Charcoal Filter (5-10 Micron) Best for Eliminating Odors

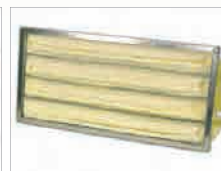

61-905 Inner Filter Bag (1 Micron)



Air Cleaner # 62-400 includes hardware for ceiling mounting