

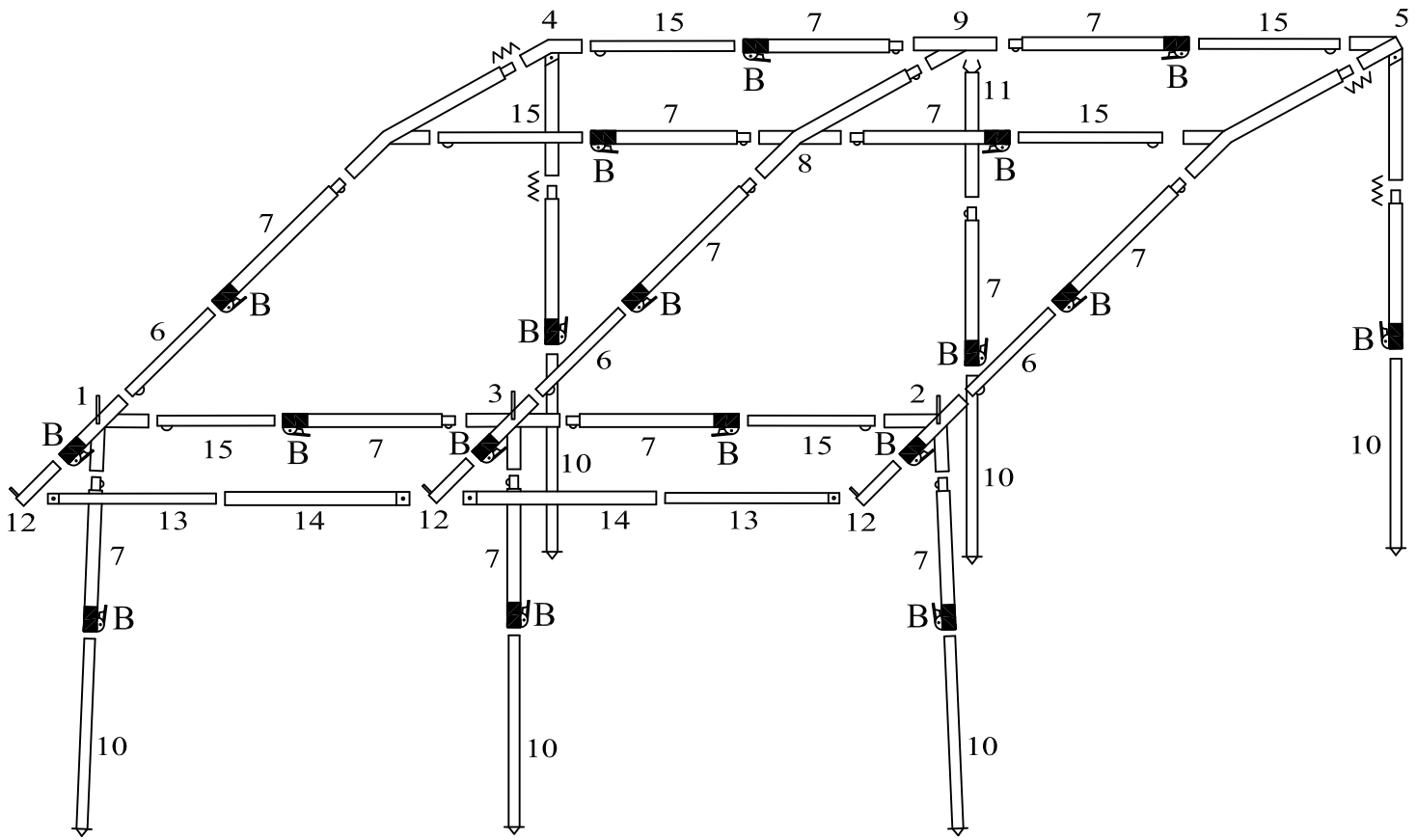

Doréma

frametekening / diagram: S25 W18 2 F PG



staal / steel

pos.	artikel nr. part no.	aantal quantity	frame deel frame part	maat mm size mm	ø mm	pos.	artikel nr. part no.	aantal quantity	frame deel frame part	maat mm size mm	ø mm
1	39503	1		215	25x1	6	39286	3		800	22x1
2	39504	1		215	25x1	7	38285-PG	13		940+60	25x1
3	39469	1		215	25x1	8	39513	1		670+60	25x1
4	39467-PG	1		A 870+30	25x1	9	39495	1		215/80	25x1
				B 940+60	25x1	10	35455	6		1100	22x1
5	39468-PG	1		C 670+60	25x1	11	34069	1		600	25x1
				W 100/100	25x1	12	37838	3		290	22x1
						13	35988	2		1100	19x1
						14	36660	2		1100	22x1
						15	38355	6		1100	22x1

Access.	Qty.
B = buisklem / adjusting clamp 25 mm	18

BEWAAR DEZE FRAMETEKENING
KEEP THIS FRAME DIAGRAM IN A SAFE PLACE
 Voor nalevering van losse framedelen altijd het framenummer en het artikelnummer opgeven.
 When ordering separate frame parts always mention the diagram number and part number.