

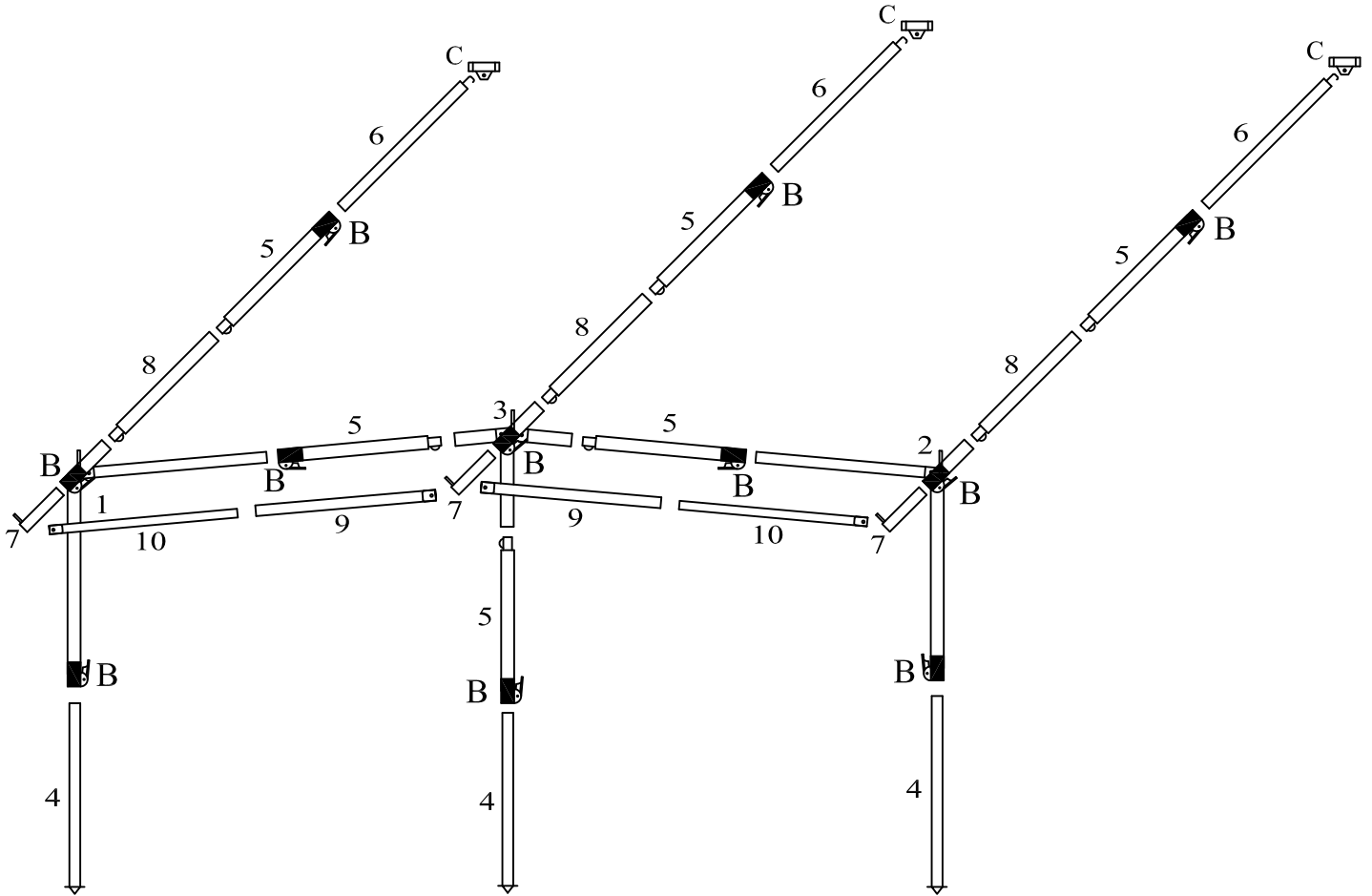

Doréma

frametekening / diagram: S25 241 22 PG



staal / steel

pos.	artikel nr. part no.	aantal quantity	frame deel frame part	maat mm. size mm.	∅ mm.	pos.	artikel nr. part no.	aantal quantity	frame deel frame part	maat mm. size mm.	∅ mm.
1	38061-PG	1		A 970+30 B 1000 W 215	25x1 22x1 25x1	6	38379	3		1100	22x1
2	38062-PG	1		A 970+30 B 1000 W 215	25x1 22x1 25x1	7	37838	3		290	22x1
3	38060-PG	1		C 570+30 D 185+30 W 215	25x1 25x1 25x1	8	38304	3		940+60	25x1
4	35455	3		1100	22x1	9	36660	2		1100	22x1
5	38285-PG	6		940+60	25x1	10	35988	2		1100	19x1

Access.	Aantal / Qty.
B = buisklem / adjusting clamp 25 mm.	11
C = tentoo / plastic eye	3
schroef / screw	6

BEWAAR DEZE FRAMETEKENING
KEEP THIS FRAME DIAGRAM IN A SAFE PLACE
 Voor nalevering van losse framedelen altijd het framenummer en het artikelnummer opgeven.
 When ordering separate frame parts always mention the diagram number and part number.