

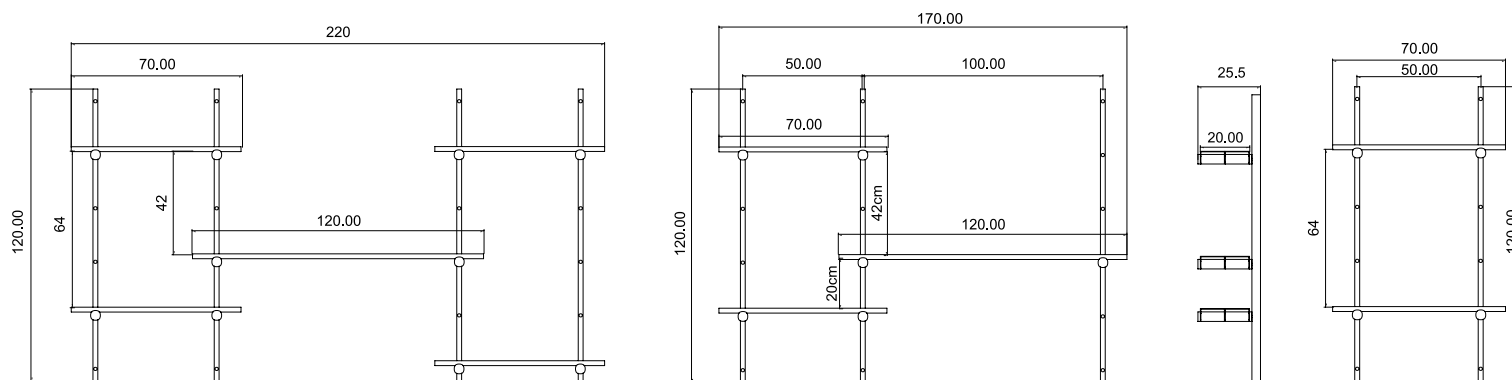

the

SHELVES SYSTEM

These shelves feature an open and minimalist design, proudly displaying structural elements and joint details. Available in various sizes.

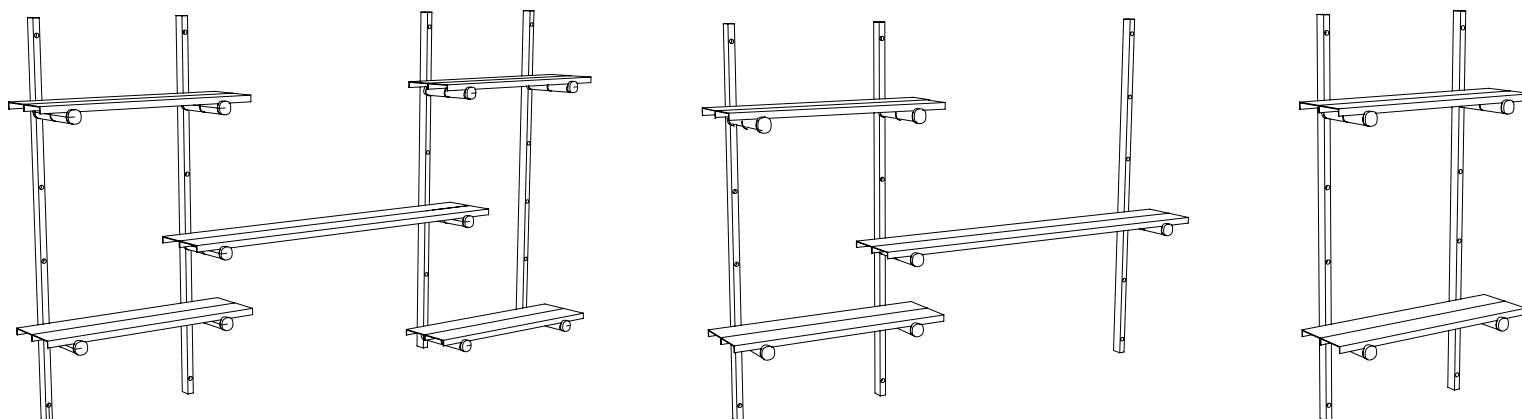

COLORS

Oak Aluminium

MATERIAL

Wood + Brushed Aluminium

DIMENSIONS / WEIGHT

220/170/70 X 120X25.5 cm

6 / 8 / 10kg

PACKAGING DIMENSIONS

130X35X15 cm / 7 / 8 / 11kg

WWW.ASAFWEINBROOM.COM

sales@weinbroom.com
tel.: +972 522 467 730