

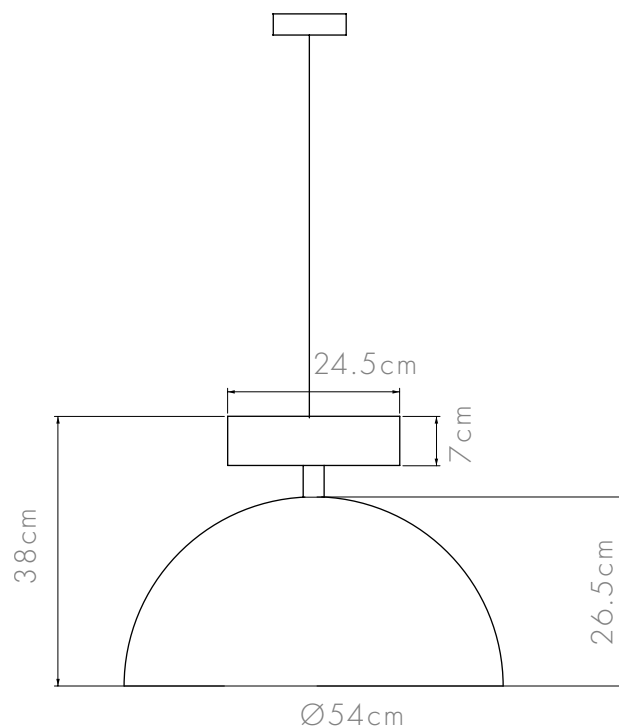

the

HANGING MOHICAN

A hanging lamp consists of a hammered wood, non-polished brass which will age with time passes, and a round metal cream shader.



COLORS

Cream

WOOD TYPES

Oak

DIMENSIONS / WEIGHT

Ø54X38 cm / 4 kg

MATERIAL

Wood + Brass + Aluminium

CANOPY

Black

FABRIC CORD

2m Black

SOCKET TYPE / WATTAGE

E27 / Led Max 20w

PACKAGING DIMENSIONS

60X60X42 cm

WWW.ASAFWEINBROOM.COM

sales@weinbroom.com
tel.: +972 522 777 271