



# SetPower

RV Dual Zone Pro Series

**User Manual**

V1.0

# CONTENT

1.PACKAGE CONTENT \_\_\_\_\_01

2.SPECIFICATIONS \_\_\_\_\_02

3.GETTING STARTED \_\_\_\_\_06









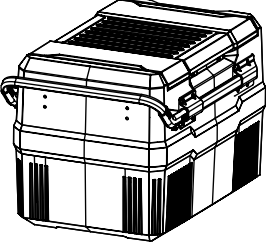

4.OPERATION \_\_\_\_\_06

5.ERROR CODES & SOLUTIONS \_10

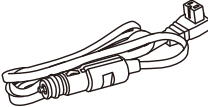
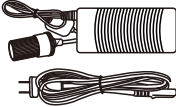
6.WARRANTY & RETURN \_\_\_\_\_11

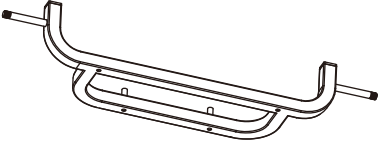
7.SAFETY INSTRUCTIONS \_\_\_\_\_13

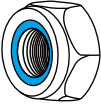
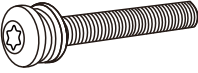
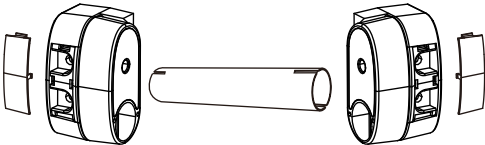
# 1. PACKAGE CONTENT

<p>Refrigerator×1</p> 	<p>Basket×1</p> 	<p>User Manual×1</p> 	<p>Supporting Base X 2</p> 
<p>DC Cable×1 (8.2 ft, 16 AWG)</p> 	<p>AC Adapter×1</p> 	<p>Spanner X 1</p> 	<p>Wheels X 2</p> 
<p>Support Frame X 1</p> 	<p>Screw For Frame X 4</p> 	<p>Nut For Wheels X 2</p> 	
<p>Hex-Head Screws For Handle X 4</p> 	<p>Elastic Handles X 1</p> 	<p>Hex Wrench X 1</p> 	

## 2.SPECIFICATIONS

Model	RV45D Pro	RV60D Pro
External Dimensions	25.4×16.7×17.3 in. (645×425×440mm)	25.4×16.7×21.1 in. (645×425×535mm)
Capacity	45 Qt / 43 L	60 Qt / 56L
Net Weight	38 lbs (17.2 kg)	41 lbs (18.8kg)
Rated Power Consumption	60W	
Temperature Range	-18°C to +10°C (0°F to 50°F)	
Power Source	DC 12V / 24V AC 110V - 240V	
Rated Current	5A / 2.5A	
Fuse	15A	

### Wheel Installation

1. Install the frame

① Take off the protective screw as **Figure 1** shows.

② The frame needs to be attached to the unit as **Figure 2** shows.

2 protruding pillars which are marked in the **Figure 2** need to be inserted into the holes at the bottom of the unit.

③ Fix the frame with 4 screws showing in the **Figure 3**.

## 2. Mount the wheels

The wheels must be properly mounted to the wheel frame with the nuts

**NOTE: The round, blue side of nuts faces outward as Figure 4 shows**

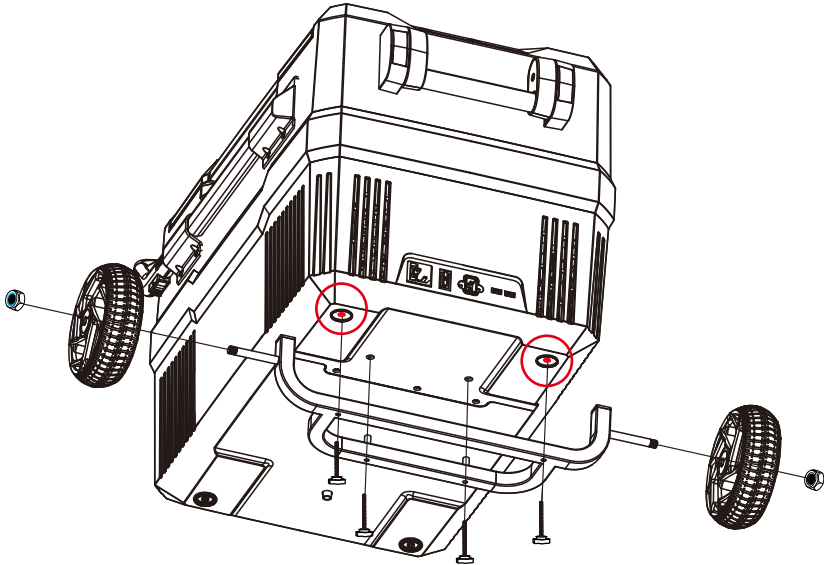
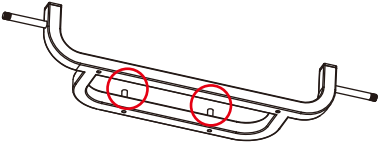

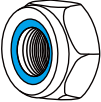



Figure 1

<p>Support Frame X 1</p>  <p>Figure 2</p>	<p>Screw For Frame X 4</p>  <p>Figure 3</p>	<p>Nut For Wheels X 2</p>  <p>Figure 4</p>
 <p>Wheels X 2</p>	 <p>Spanner X 1</p>	

## Supporting Base Installation

Rotate and tighten the supporting base as **Figure 5** shows.

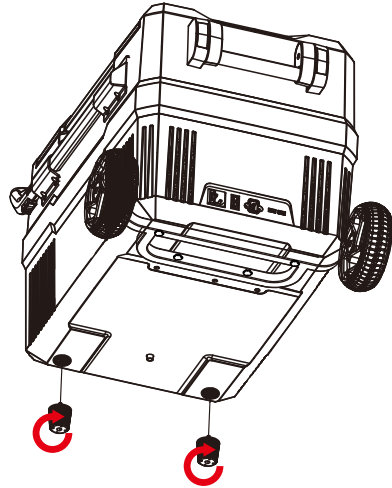

Figure 5

## Retractable Rod Installation

The Usage of Retractable Rod

There are two lock buttons on the rod at the position marked in **Figure 6**. **Press them to unlock and adjust the length of the rod, release the buttons to lock.**

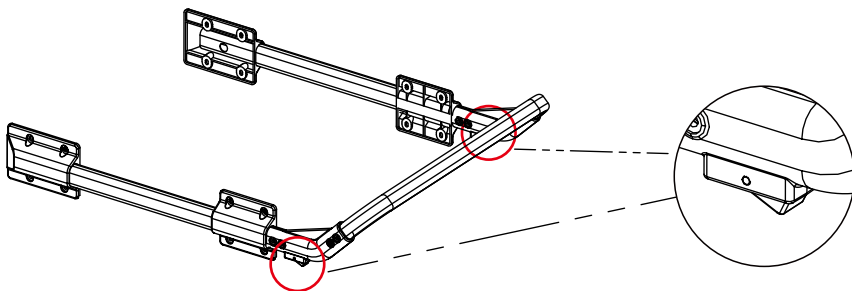
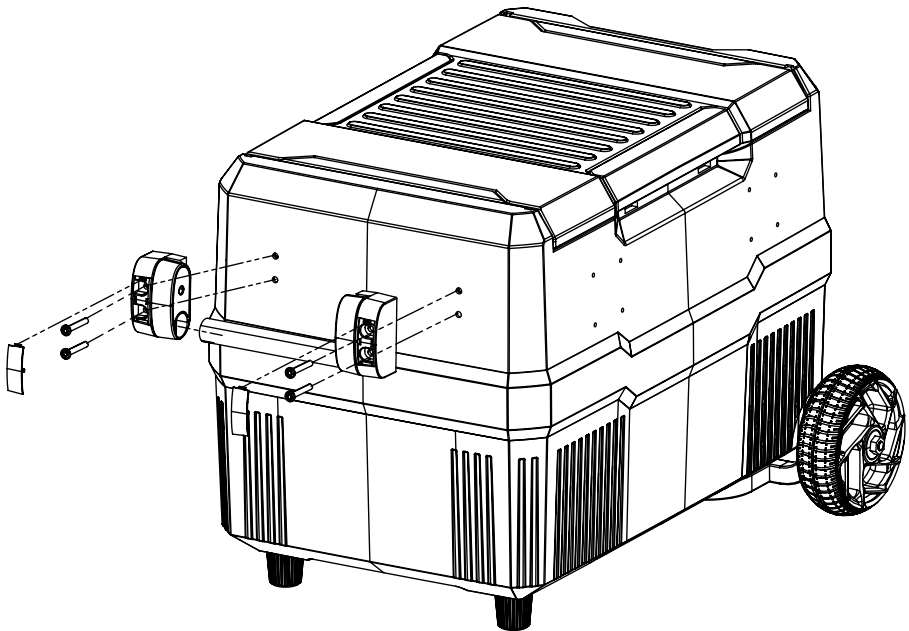
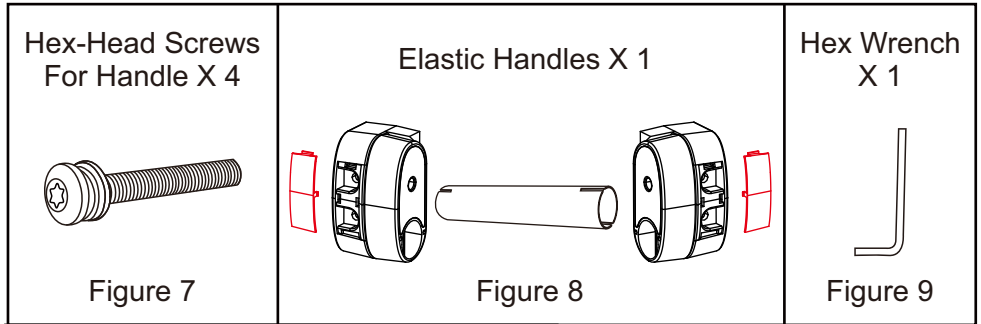

Figure 6

## Installation of Spring Loaded Handle

1. Fix one handle mount at the side of unit with hex-head screw showing in **Figure 7**, then install the mount cover showing in **Figure 8**.
2. Insert the handle bar into the fixed handle mount
3. Install another handle mount, and fasten the screw with hex wrench showing in **Figure 9**. Don't forget the mount cover, fix it and finish the installation.



## 3. GETTING STARTED

### Some Reminders

1. If the device was not placed in the upright position after transit and delivery, **please keep it upright for 24 hours** to make sure that the compressor can work properly.
2. If the device can't turn on or you encounter other problems for first time use, please contact us for help.
3. **Pre-cool** the empty unit before using it to enhance system efficiency.

## 4. OPERATION

**All descriptions in this manual are based on the control panel facing right.**

### 1 Control Panel

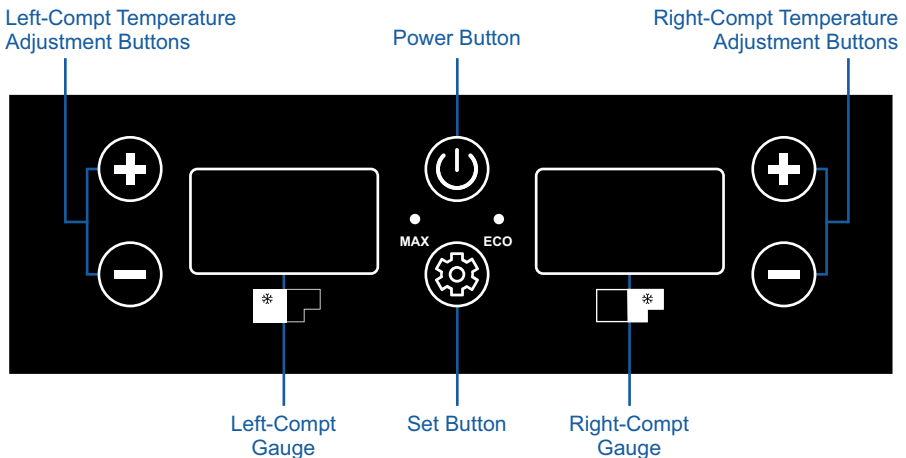

**Note: Left compartment refers to the part on the left side of the divider, while the right one is the part upon the compressor.**



## 2 Switched-on/off

With the unit plugged in, press **Power Button** to switch on/off the unit.

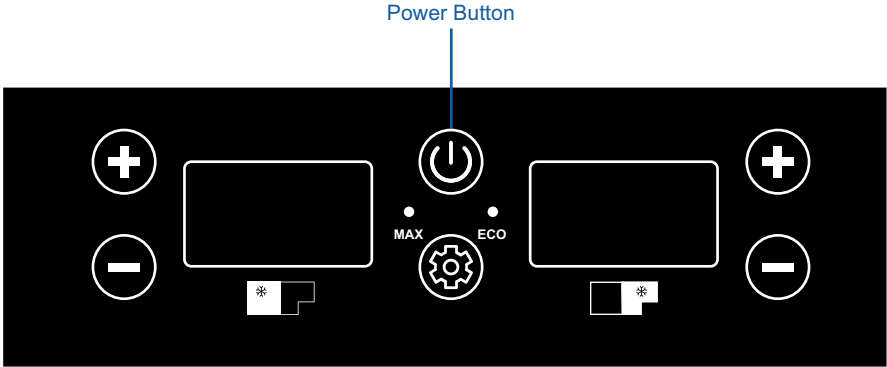

## 3 Temperature Adjustment

The **Default Target Temperature** for Left Compartment is **0°F**, while the right one is **41°F**.

Press corresponding + or – to adjust the target temperature, the target value will flash on the gauge. The temperature will change one degree on every press.

**Holding** the button can accelerate the changing process.

Left-Compt Temperature Adjustment Buttons

Right-Compt Temperature Adjustment Buttons

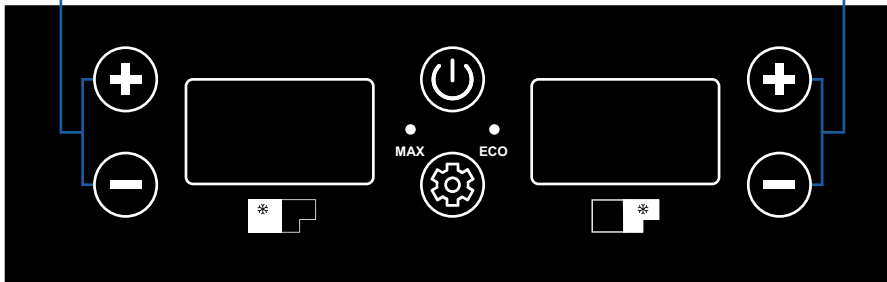

## 4 Max/Eco Mode

With the unit turned on, press the **Set Button** to toggle between Max (Fast Cooling) Mode and Eco (Energy Saving) Mode. The corresponding light will be on at the same time: the blue light is for Max mode, while green one refers to Eco Mode.

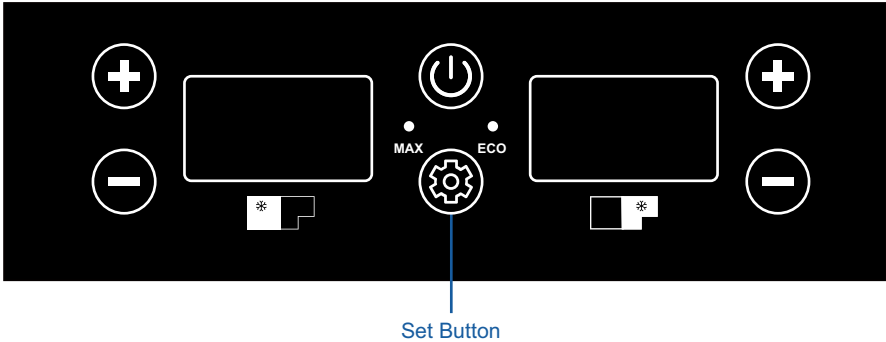

## 5 Settings Menu

In **Stand-by Mode** (unit turned off but plugged into power), **press and hold + and – Buttons (Right-Compt) at the same time for 3 seconds** to enter into the **Settings Menu**, which contains two functions, Pr(Battery Protection Settings) and CF(°C/°F Settings). Press **Power Button** to toggle between Battery Protection Settings and °C/°F Settings.

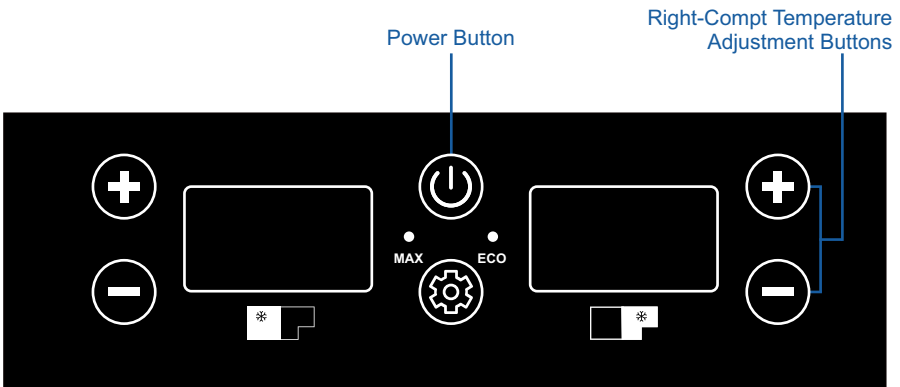

## 5.1 Battery Protection Settings

When “Pr” displays on the right gauge, press + or – button(Right-Compt) to choose protection level. There are 3 protection levels available, “==” refers to Middle Level, which is also the default value. “≡≡” means High Level, “--” means Low Level.

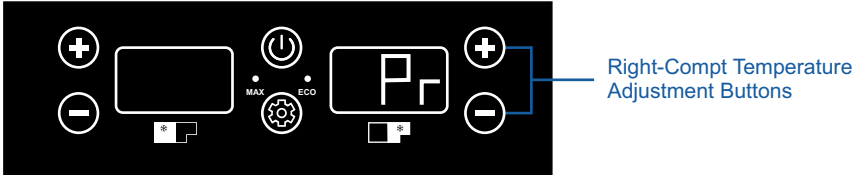

### What is Battery Protection Settings?

This function is designed to prevent over-discharge and battery depletion. When the measured DC voltage is below the Cut-off value, the compressor will shut off to prevent battery depletion. After the voltage is higher than Start-up value, the compressor will go back to work again. Improper protection setting or low-power battery may cause E1 error, please lower the battery protection or recharge the battery in time.

Protection Level Power Source	Mid Level is the Default Setting					
	HIGH		MID		LOW	
Display	≡≡		==		--	
	Start-up	Cut-off	Start-up	Cut-off	Start-up	Cut-off
12V	12.4V	11.1V	11.7V	10.4V	10.9V	9.6V
24V	25.7V	24.3V	24.2V	22.8V	22.7V	21.3V

## 5.2 Switch Between °C to °F

When “CF” displays on the right gauge, press + or –(Right-Compt) to switch between C(Celsius) and F(Fahrenheit).

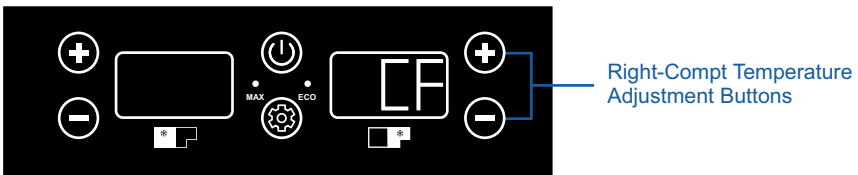

## 6 Divider Removal and Installation

If the divider is removed from the unit, it will function as a single zone unit, and only one temperature setting will become available.

### IMPORTANT!

Every time the divider is removed or installed, the target temperature will be reset to default value and need to set it again.

## 5.ERROR CODES & SOLUTIONS

Error Codes	
<b>E1 Low Input-Voltage Error</b>	The Input DC voltage is below the protection setting and the battery protection is activated.
<b>E2 Fan Error</b>	The cooling fan overloads with more than 1A Current.
<b>E3 Motor Start Error</b>	The motor of compressor is blocked or the pressure difference in the refrigeration system is too high.
<b>E4 Minimum Motor Speed Error</b>	The compressor overloads and the motor can not maintain its minimum speed.
<b>E5 Ambient Temperature Error</b>	The refrigeration system overloads, or the ambient temperature is too high, the control is overheated.
<b>E6 Thermal Sensor Fault</b>	Thermal Sensor is open-circuited or short-circuited.

## Solutions

If error code appears when the fridge is operating on 12V DC, please try to lower the battery protection setting and see if the error is resolved.

The battery protection mode may be triggered prematurely on certain vehicles due to small wiring imperfections, contributing to a measured DC voltage drop at compressor start-up. Lowering the battery protection setting may resolve this issue.

Please also try to take a voltage reading of your battery to make sure it is not depleted/discharged.

If possible, please connect the AC power cord to try if the refrigerator appears E1 code.

**Please contact us directly if the error persists.**

## 6. WARRANTY & RETURN

### 1 Warranty

- 3-year Warranty for The Compressor
- 1-year General Warranty
- For Warranty Registration, please contact us for more information.

## 2 Customer Service

- If the product is received damaged or defective, you can contact us via these ways:
  - Customer Support Email: [support@setpowerusa.com](mailto:support@setpowerusa.com)
  - Amazon Message Service
- If you email us, these information needs to be included:
  - Order ID
  - Unit Model
  - Phone number
  - Description of the Defect
  - Delivery Address
  - Videos or Photos Related to The Defect

### Note:

- **Videos or photos** is preferred, because they can help us find out the reason causing the issue and improve the efficiency of solving problems.
- If calling the customer service number out of working time, you can leave a voice/text message. We will respond to you after getting back to work.

## 3 Return Policy

### — Amazon-Fulfilled Order

The postage is afforded by Amazon in Amazon return window.

If the return window is expired but still in warranty, the return policy will be same as seller-fulfilled order.

### — Seller-Fulfilled Order

If the warranty is not expired, the postage is afforded when the return is confirmed to be caused by **QUALITY ISSUE** of our products.

## 4 Refund & Replacement

- For returns or exchanges, all accessories must be returned in the original condition and packaging.
- After the unit is shipped, please provide us with the tracking number and carrier, so we can track it and process the refund in time.
- After the package is delivered back to our warehouse, a full refund will be initiated.
- If you file a return request on Amazon, we will process it in 48 hours and contact you via Amazon Message Service, please pay attention to your Amazon Message Box or Email in order to **avoid missing important notifications.**

## **7.SAFETY INSTRUCTIONS**

**Please read the user manual and safety instructions carefully before using the appliance.**

### **1 Disclaimer**

The manufacturer cannot be held responsible for the damage resulting from improper usage or incorrect operation.

The use of accessories that are not recommended by manufacturer can cause injuries and will invalidate any warranty that you may have.

This appliance is not intended for use by persons (including children) with reduced physical, sensory or mental capabilities, or lack of experience and knowledge. Unless they have been given supervision or instruction concerning use of the appliance by a person responsible for their safety.

## **2 Energy Saving Tips**

- Place the unit on a dry, secure surface, with adequate ventilation.
- Please make sure the lid is closed and secure, and only open the fridge when you need to.
- Please cool down hot/warm food before put it into the unit.
- Please defrost the unit when ice forms on the internal walls or lid.
- Select proper target temperature according to corresponding need.

## **3 Cleaning & Maintenance**

- Please power off and unplug the unit before cleaning or Maintenance.
- Please use non-abrasive detergent to cleaning the interior/exterior of the fridge.
- Please don't scrap the interior of the fridge to defrost/de-ice the fridge.
- Please don't pressure-wash/spray the fridge with a running water hose.



## 4 Dos and Don'ts

- Do not expose the unit to moderate/heavy rain.
- Do not use this appliance near direct heat sources, such as flame or radiator.
- Do not place open containers of liquid inside the fridge.
- Place/arrange the content of your fridge securely before using the refrigerator inside a moving vehicle.
- Do not use electrical devices inside the food storage compartments of the appliance, unless approved/recommended by the manufacturer.
- Do not store explosive items, such as aerosol cans with a flammable propellant in this appliance.
- Do not touch the compressor or the condenser when the fridge is operating.
- Do not store explosive substances such as aerosol cans with a flammable propellant in this appliance.
- Please ensure the supply cord is not trapped or damaged before setting up the appliance.

## 5 INTENDED TO USE

**This appliance is intended to be used in household and similar applications such as:**

Staff kitchen areas in shops, offices and other working environments;  
Farm houses and hotels, motels and other residential type environments;

Bed and meal environments;

Catering and similar non-retail applications.



### **DANGER**

**Failure to obey the following warnings could result in death or serious injury:**

**ELECTRICAL SHOCK HAZARD.**

- Do not immerse the product in water, or use it in an excessively muddy area.
- Do not use the cooler for any purpose other than as a portable cooling device.

### **FALL HAZARD**

- Do not stand on the cooler, which may damage the unit or injure yourself.

### **RISK OF CHILD ENTRAPMENT**

Before you throw the unit away:

- Take off the doors.
- Leave the shelves in place so that children can not easily climb into it.

# ***OUR GUARANTEE***

**SetPower product comes with a 3-year warranty on the compressor and 1 year warranty on all other parts for your peace of mind. In the unlikely event this product fails when used according to our user guide, we will either repair or replace it. For full warranty terms and conditions on this product, please see the user guide.**

**We'd welcome you contact us [support@setpowerusa.com](mailto:support@setpowerusa.com) if you have any question about the product.**

## ***Quality Service Guarantee***

**This product is warranted for 3 years on the compressor and 1 year for all other parts from the date of purchase. Our goods come with guarantees that cannot be excluded under the Local Consumer Law. You are entitled to a replacement or refund for a major failure and compensation for any other reasonably foreseeable loss or damage. You are also entitled to have the goods repaired or replaced if the goods fail to be of acceptable quality and the failure does not amount to a major failure. Warranty does not cover products that have not been used in accordance with user guide or are outside the warranty terms and conditions.**



[official@setpowerusa.com](mailto:official@setpowerusa.com)

[support@setpowerusa.com](mailto:support@setpowerusa.com)

# SetPower

**3-YEAR WARRANTY**

