



SetPower

PT35/45/55

User Manual

V1.0

CONTENT

1.SAFETY INSTRUCTIONS _____01

2.DATA SHEET _____04

3.OVERVIEW _____05

4.USE REMINDERS _____05

5.OPERATING INSTRUCTIONS _____07

6.TROUBLE SHOOTING _____07

7.WARRANTY _____13

1. SAFETY INSTRUCTIONS

Please read the user manual and safety instructions carefully before using the appliance.

1.1 Disclaimer

The manufacturer cannot be held responsible for the damage resulting from improper usage or incorrect operation.

The use of accessories that are not recommended by manufacturer can cause injuries and will invalidate any warranty that you may have.

This appliance is not intended for use by persons (including children) with reduced physical, sensory or mental capabilities, or lack of experience and knowledge. Unless they have been given supervision or instruction concerning use of the appliance by a person responsible for their safety.

1.2 Energy Saving Tips

- Place the unit on a dry, secure surface, with adequate ventilation.
- Please make sure the lid is closed and secure, and only open the fridge when you need to.
- Please cool down hot/warm food before put it into the unit.
- Please defrost the unit when ice forms on the internal walls or lid.
- Select proper target temperature according to corresponding need.

1.3 Cleaning & Maintenance

- Please power off and unplug the unit before cleaning or Maintenance.

- Please use non-abrasive detergent to cleaning the interior/exterior of the fridge.
- Please don't scrap the interior of the fridge to defrost/de-ice the fridge.
- Please don't pressure-wash/spray the fridge with a running water hose.

1.4 Dos and Don'ts

- Do not expose the unit to moderate/heavy rain.
- Do not use this appliance near direct heat sources, such as flame or radiator.
- Do not place open containers of liquid inside the fridge.
- Place/arrange the content of your fridge securely before using the refrigerator inside a moving vehicle.
- Do not use electrical devices inside the food storage compartments of the appliance, unless approved/recommended by the manufacturer.
- Do not store explosive items, such as aerosol cans with a flammable propellant in this appliance.
- Do not touch the compressor or the condenser when the fridge is operating.
- Do not store explosive substances such as aerosol cans with a flammable propellant in this appliance.
- Please ensure the supply cord is not trapped or damaged before setting up the appliance.

1.5 INTENDED TO USE

This appliance is intended to be used in household and similar applications such as:

Staff kitchen areas in shops, offices and other working environments;
Farm houses and hotels, motels and other residential type environments;

Bed and meal environments;

Catering and similar non-retail applications.



DANGER

Failure to obey the following warnings could result in death or serious injury:

ELECTRICAL SHOCK HAZARD.

- Do not immerse the product in water, or use it in an excessively muddy area.
- Do not use the cooler for any purpose other than as a portable cooling device.

FALL HAZARD

- Do not stand on the cooler, which may damage the unit or injure yourself.

RISK OF CHILD ENTRAPMENT

Before you throw the unit away:

- Take off the doors.
- Leave the shelves in place so that children can not easily climb into it.

2.SPECIFICATIONS

Model	PT35	PT45	PT55
External Dimensions (L*W*H)	24.4×15.8×17.1 inches (620×400×435mm)	34.6×18.9×18.2 inches (620×400×505mm)	34.6×18.9×18.2 inches (620×400×575mm)
Capacity	37 Qt / 35 L	47.6 Qt / 45L	58.1 Qt / 55L
Net Weight	38 lbs (17.3 kg)	42 lbs (19.1kg)	44 lbs (20.1kg)
Temperature Range	0°F to 50°F (-18°C to +10°C)		
Nominal Voltage	DC 12V / 24V		
Refrigerant Gas	R134a-CFC Free		
Systems Control	Compressor speed: MAX: 3500r/min, ECO: 2500r/min		
Shell Material	PP、Metal、PU leather		

3.OVERVIEW

1. Lid Latches
2. Control Panel
3. Carry Handle
4. Power Input Panel
5. 12V/24V DC Power Cable
6. AC/DC Power Adaptor

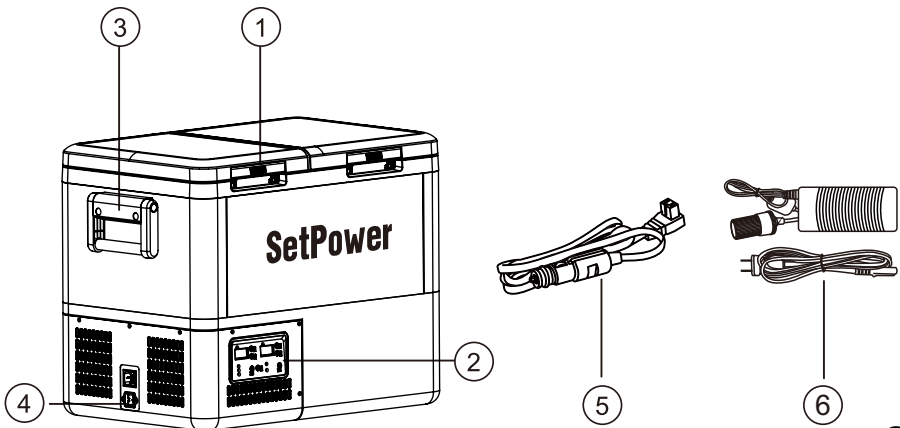

37Qt (35L) FRIDGE

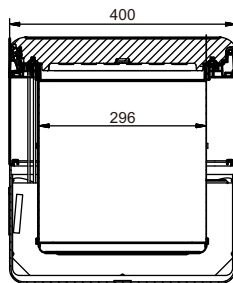
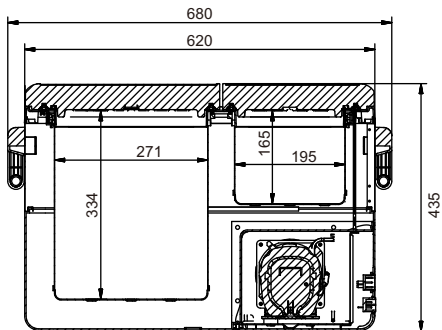

47. 6Qt (45L) FRIDGE

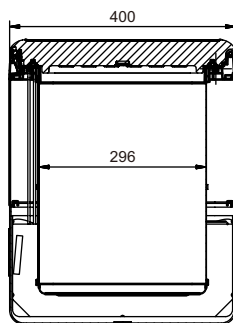
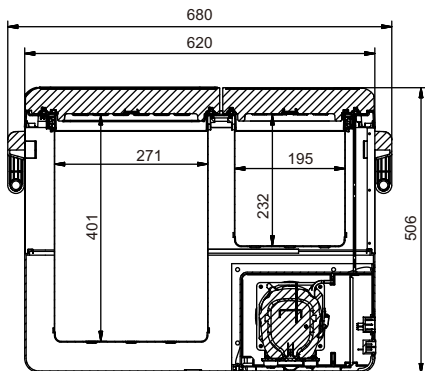

58.1Qt (55L) FRIDGE

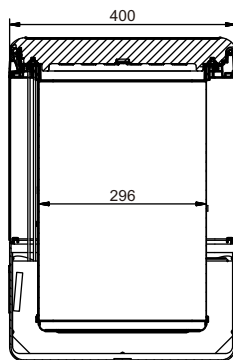
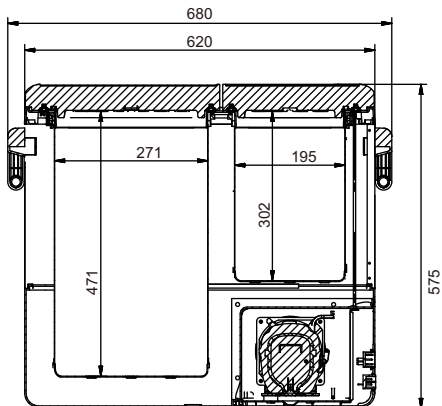

4. USE REMINDERS

Some Reminders

1. If the device was not placed in the upright position after transit and delivery, **please keep it upright for 24 hours** to make sure that the compressor can work properly.
2. If the device can't turn on or you encounter other problems for first time use, please contact us for help.
3. **Pre-cool** the empty unit before using it to enhance system efficiency.

5. OPERATING INSTRUCTIONS

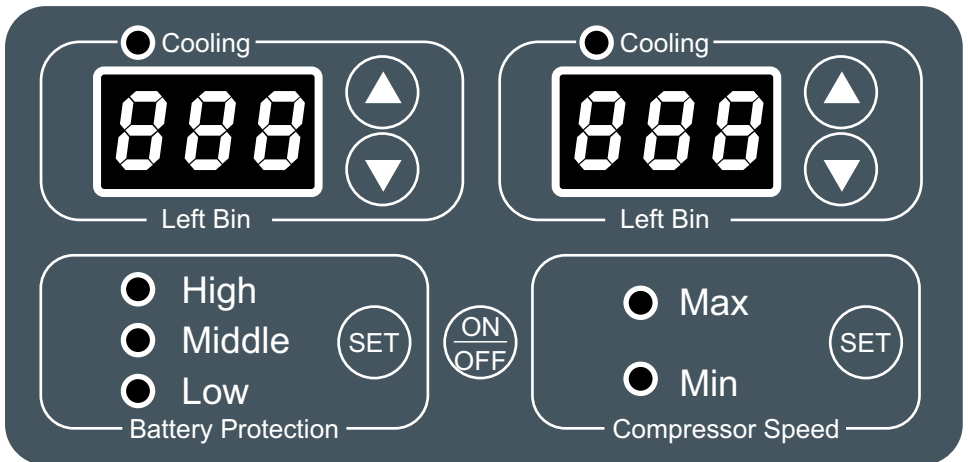

5.1 HOW TO USE THE REFRIGERATOR

5.1.1 Connecting with 12V or 24V

Connect the feeding cable to a direct current 24V DC power source.

- Make sure the polarity is right.
- If connected to an existing cigarette plug, please carefully check up that power supply is sufficient.
- If the supplied power cable is not used, please see the table containing the information related to the cable section:













The Fridge/Freezer is designed to operate on DC voltage inputs.







DC input	12V or 24V
DC cable	2.5m,16AWG

5.1.2 Connecting with 110-240V

The Fridge/Freezer is designed to operate on DC voltage inputs only. Use the supplied AC/DC adaptor to operate fridge on 240V AC.

5.2 Operation

- **TURN ON OR TURN OFF THE FRIDGE:** when the fridge turn on, press and hold the "  " button for 2 seconds to enter the standby state. In the standby state, press and hold the "  " button for 2 seconds to turn on.
- **TEMPERATURE SETTING:** under the startup state, press the "  " button to increase one degree temperature; press the "  " button to reduce the temperature by one degree. Press and hold for 3 seconds "  " or "  " button to adjust upward or downward the temperature at 3 degree per second.
- **ADJUST LEFT OR RIGHT ZONE TEMPERATURE:** operate the "  " or "  " button on the LEFT BIN area, to set LEFT ZONE temperature. Operate the "  " or "  " button on the RIGHT BIN area, to set RIGHT ZONE temperature. The left zone is adjusted at 0°C by default. The right zone is adjusted at 3°C by default.
- **TEMPERATURE SWITCH BETWEEN FAHRENHEIT & CELSIUS:** under the fridge turn on condition, press and hold at the same time "  " and "  " button AT THE RIGHT BIN, to switch between Fahrenheit and Celsius. F refers to Fahrenheit; C refers to Celsius. Celsius is defaulted.

- **SWITCH MAX OR ECO MODE:** under the fridge turn on condition, press and hold the "  " button in the COMPRESSOR SPEED area, to switch MAX or ECO mode. ECO mode is defaulted.
- **SWITCH SINGLE OR DUAL ZONE:** when the dual zone at work, press and hold "  " and "  " button for 2 seconds to stop one zone refrigeration, the corresponding screen will turn rest. When the single zone is working, press and hold the "  " and "  " button at the same time for 2 seconds of the turn-off zone, the cooling function and the corresponding display screen will restore. When the single zone is working, it's unable to turn off the fridge by press and hold "  " and "  " button.

5.3 BATTERY PROTECTION FUNCTION

Under the startup state, press "  " button at BATTERY PROTECTION zone to enter the battery protection function, then choose HIGH/MID/LOW, the corresponding indicator shows the battery protection settings. H is defaulted by factory.

Input voltage Protection mode	12V		24V	
	protection value(V)	recovery value(V)	protection value(V)	recovery value(V)
L	9.6	10.9	21.3	22.7
M	10.4	11.7	22.8	24.2
H	11.1	12.4	24.3	25.7

What is Battery Protection Settings?

This function is designed to prevent over-discharge and battery depletion. When the measured DC voltage is below the Cut-off value, the compressor will shut off to prevent battery depletion. After the voltage is higher than Start-up value, the compressor will go back to work again. Improper protection setting or low-power battery may cause E1 error, please lower the battery protection or recharge the battery in time.

6. TROUBLESHOOTING

6.1 POWER CUTTING IN/OUT

- Your fridge has built in battery protection and needs a minimum 10.9V to start and 9.6V to continue operating.
- During operation a load is placed on the circuit and power supply and the voltage can drop by as much as 2V, many things can affect voltage drop, such as: increased resistance from long cables, or cables that are undersized or oversized for the application. Poor or loose connections can also increase resistance.
- **For example:** The fridge turns on runs for 1 minute then turns off. The likely problem is that the battery and wiring circuit have sufficient voltage to start but when a load is applied (the compressor starting) the voltage will drop below 9.6 and the fridge turns off. This cycle will repeat as the load is removed from the battery the voltage will begin to show 10.6 which is enough to start the cycle again. Try to test fridge with 2 separate batteries before raising a warranty claim.
- **NOTE:** If the fridge is able to run on the AC/DC transformer the problem is likely a faulty battery, wiring or connection.

6.2 COMMON 12V POWER SUPPLY ISSUES

Wiring

The standard wiring from the car battery to the 12V outlet may not be rated to power the fridge.

Ensure the wire gauge is of sufficient size to supply the fridge's current draw over the length required.

If unsure, check with the vehicles instruction manual or, contact a local automotive electrician for advice.

NOTE: Always fuse wiring with an in-line 15A fuse as close as reasonable possible to the power source (i.e. the battery).

Battery

The car battery could be old, undersized or have a dead cell causing too much voltage drop. If the battery contains a dead cell it may still show that it has voltage with no load applied. When a load is applied the cell will drop and subsequently so will the voltage.

Connections

The 12V plug, car 12V socket or any of the connections between the fridge and the battery could be faulty or have come loose since installation.

6.3 ERROR CODES & SOLUTIONS

When the refrigerator fails, the digital screen displays the failure mode, as shown in the following table:

CADE	Error Type	Action
E1	Battery voltage low protection (Module input voltage is lower than the set value).	Check battery voltage and adjust Low Voltage Cut-Off as required.
E2	Fan fault (electric current >0.65A) / Frequent start-stop.	Contact seller.
E3	The compressor starts incorrectly (The motor is blocked or the pressure difference of the cooling system is too large).	Ambient temperature may be too high, please clear the air vents, if the problem hasn't been solved, please contact seller.
E4	The compressor speed is too low (the refrigeration system is overloaded and the motor cannot be maintained 1850r/min as minimum speed) the requirements.	
E5	Protects the compressor control module from over-temperature or under-temperature (When the ambient temperature is too high or too low, or the system is overloaded, making the module/ ECU internal temperature > 100°C or < -10°C).	
HH	NTC short circuit fault.	Contact seller.
LL	NTC open-circuit fault.	

If a single zone reports NTC failure, which means this zone stops working, and the other zone can still be normally refrigerated; When both zones report NTC failure, which means the compressor stops working.

7. WARRANTY & RETURN

7.1 Warranty

- 3-year Warranty for The Compressor
- 1-year General Warranty
- For Warranty Registration, please contact us for more information.

7.2 Customer Service

- If the product is received damaged or defective, you can contact us via these ways:
 - Customer Support Email: support@setpowerusa.com
 - Amazon Message Service
- If you email us, these information needs to be included:
 - Order ID
 - Unit Model
 - Phone number
 - Description of the Defect
 - Delivery Address
 - Videos or Photos Related to The Defect

Note:

- **Videos or photos** is preferred, because they can help us find out the reason causing the issue and improve the efficiency of solving problems.
- If calling the customer service number out of working time, you can leave a voice/text message. We will respond to you after getting back to work.

7.3 Return Policy

— Amazon-Fulfilled Order

The postage is afforded by Amazon in Amazon return window.

If the return window is expired but still in warranty, the return policy will be same as seller-fulfilled order.

— Seller-Fulfilled Order

If the warranty is not expired, the postage is afforded when the return is confirmed to be caused by **QUALITY ISSUE** of our products.

7.4 Refund & Replacement

- For returns or exchanges, all accessories must be returned in the original condition and packaging.
- After the unit is shipped, please provide us with the tracking number and carrier, so we can track it and process the refund in time.

- After the package is delivered back to our warehouse, a full refund will be initiated.
- If you file a return request on Amazon, we will process it in 48 hours and contact you via Amazon Message Service, please pay attention to your Amazon Message Box or Email in order to **avoid missing important notifications.**

OUR GUARANTEE

SetPower product comes with a 3-year warranty on the compressor and 1 year warranty on all other parts for your peace of mind. In the unlikely event this product fails when used according to our user guide, we will either repair or replace it. For full warranty terms and conditions on this product, please see the user guide.

We'd welcome you contact us support@setpowerusa.com if you have any question about the product.

Quality Service Guarantee

This product is warranted for 3 years on the compressor and 1 year for all other parts from the date of purchase. Our goods come with guarantees that cannot be excluded under the Local Consumer Law. You are entitled to a replacement or refund for a major failure and compensation for any other reasonably foreseeable loss or damage. You are also entitled to have the goods repaired or replaced if the goods fail to be of acceptable quality and the failure does not amount to a major failure. Warranty does not cover products that have not been used in accordance with user guide or are outside the warranty terms and conditions.



official@setpowerusa.com

support@setpowerusa.com

SetPower

3-YEAR WARRANTY

