

MT6 *QUAD POD*

PARTS LIST & INSTALLATION INSTRUCTION MANUAL 2024



TABLE OF CONTENTS

SECTION 1: VISUAL BREAKDOWN.....	3
SECTION 2: COMPONENTS	4
SECTION 3: HARDWARE.....	4
SECTION 4: INSTALLATION INSTRUCTIONS	5,9
SECTION 5: MANUFACTURER’S WARRANTY	9

IMPORTANT INFORMATION

The location of the frame is critical when dealing with windy environments. A site visit by a local installer or manufacturer representative is critical in order to protect your investments.

These frames can withstand wind gusts of up to 80 KM/H, however they cannot sustain with a constant wind speed of 80 KM/H+.

IF YOU ARE PLANNING TO INSTALL THIS PRODUCT IN A OPEN PRAIRIE SETTING OR LAKEFRONT COTTAGE PROPERTY IT IS CRITICAL TO COLLECT HISTORIC WIND SPEED DATA FOR YOUR AREA TO ENSURE WIND SPEEDS DO NOT HAVE A HISTORY OF EXCEEDING OUR MANUFACTURER SPEC OF 80KM/H. INSTALLING THIS PRODUCT WITHOUT FOLLOWING MANUFACTURER RECOMMENDATIONS MAY AFFECT YOUR WARRANTY COVERAGE AND WILL BE CONSIDERED AS “INSTALLED AT OWN RISK”.

If installed in a public setting fencing is required. Please check your local by-laws for requirements in your area.

Some hardware will come pre-assembled on the units and may or may not be included in the hardware breakdown.

Section 1: Visual Breakdown

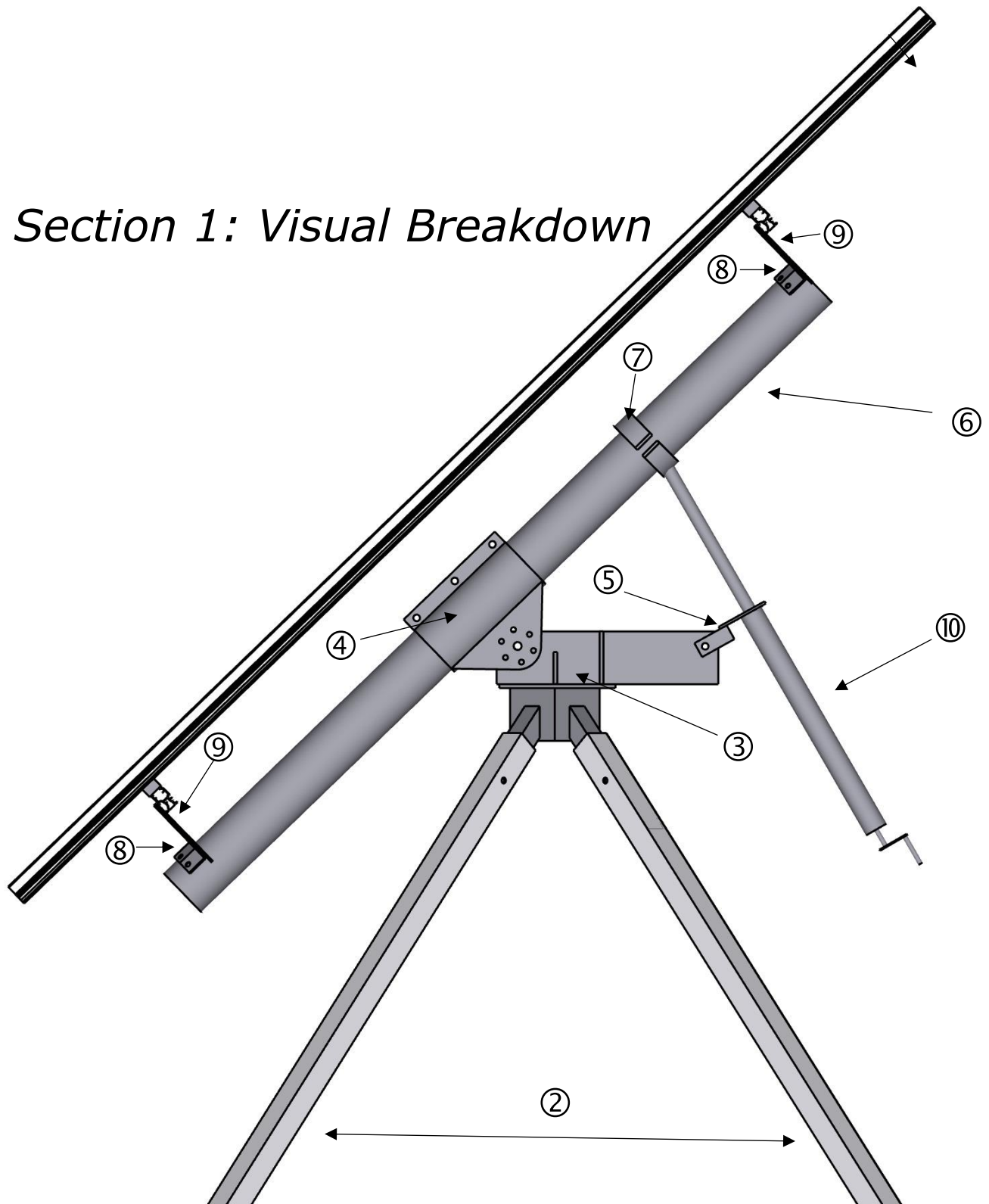

Section 2: Components

ITEM NO.	PART NUMBER	DESCRIPTION	QTY.
1	L017	FOOT WELDMENT	4
2	L020	LEG -ALUMINUM	4
3	SB08	STRONGBACK LEG ADAPTOR	1
4	WM004-1	TRIANGULAR CLAMP	1
5	JP001	JACKPLATE	1
6	WF001	WING FRAME TUBE	1
7	JC001	JACK-CLAMP ASSEMBLY	1
8	WM003-2	WING MOUNT WELDMONT	3
9	AF004	WING FRAME (PAIR)	3
10	JC002	SIDE-WIND JACK	1

Section 3: Hardware

A	HW001	SAE GR.8 7/16"-14UNC NYLOCK HEX NUT, ZINC PLATED	8
B	HW002	SAE GR.8 7/16"-14UNC X 1" LONG HEX BOLT, ZINC PLATED	8
C	HW003	SAE GR.8 3/8" -16UNC X 2" LONG JACKING CAP SCREW	6
D	HW004	SAE GR.8 1/2"-13UNC X 2" LONG HEX BOLT, ZINC PLATED	11
E	HW005	SAE GR.8 1/2"-13UNC NYLOCK	11
F	HW006	SAE GR.8 1/2" FLAT WASHER, ZINC PLATED	16
G	KMC001	KINETIC MID CLAMP	8
H	KEC001	KINETIC END CLAMP	8
I	KLB001	KINETIC (L) BRACKET	8
J	KSN001	KINETIC STUD WITH NUT	10
K	KR001	KINETIC RAIL	8

Section 4: Installation Instructions

1. Unpack and lay out all components on the ground. Prepare the hardware with the correct wrenches and sockets needed.
2. Connect the **Foot weldments (1)** to the **Aluminum legs (2)** complete all 4 units with **Hardware (D, E)** and Torque bolts to **64ft-LBS.**

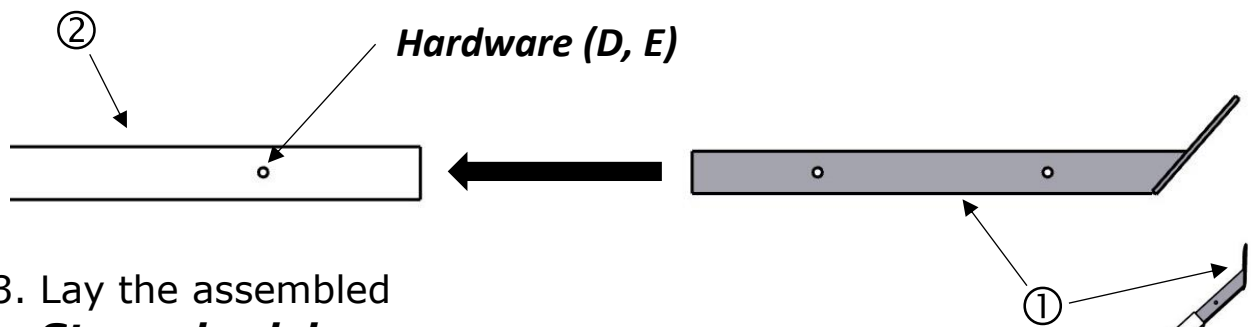

3. Lay the assembled **Strong back leg adaptor (3)** on its side, insert 3 of the assembled legs and install the **Hardware (D, E)**. Lift the unit up and install the fourth leg and torque all the bolts to **64ft-lbs.**

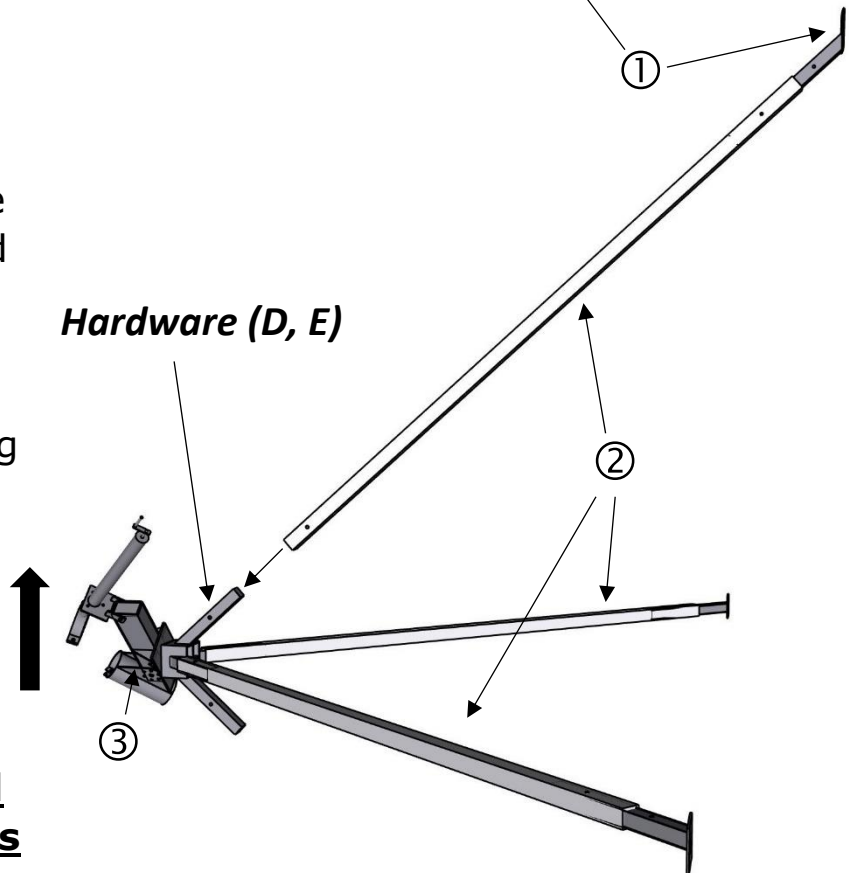

4. Set the assembled structure on the **Engineered base or pads approved for your location's environmental requirements.** Anchor the 4 points and torque to manufacturer recommended specifications.

5. Remove to top sections of the **Jack-Clamp assembly (7)**. Insert the **Wing frame tube (6)** into the **Triangular clamp (4)** to the predetermined location marked on the **Wing frame tube (6)**. Raise the **Side wind jack (10)** until it contacts the **Wing frame tube (6)** and install the top section of the **Jack clamp assembly (7)** loosely. The lower **Wing mount weldment (8)** will come factory installed and torqued, make sure to install it in the direction matching to the one shown below in **(Figure A)**. Once in the correct location, place a level on the **Wing mount weldment (8)** and slack off the **Jacking cap screws (C)** to hold the **Wing frame tube (6)** in place and plumb. .

NOTE: DO NOT TORQUE HARDWARE (D, E) WITHOUT COMPLETELY SLACKING OFF THE JACKING CAP SCREWS (14). FAILURE TO DO SO MAY RESTRICT THE TRIANGULAR CLAMP (4) FROM CORRECTLY SECURING THE WING FRAME TUBE (6)

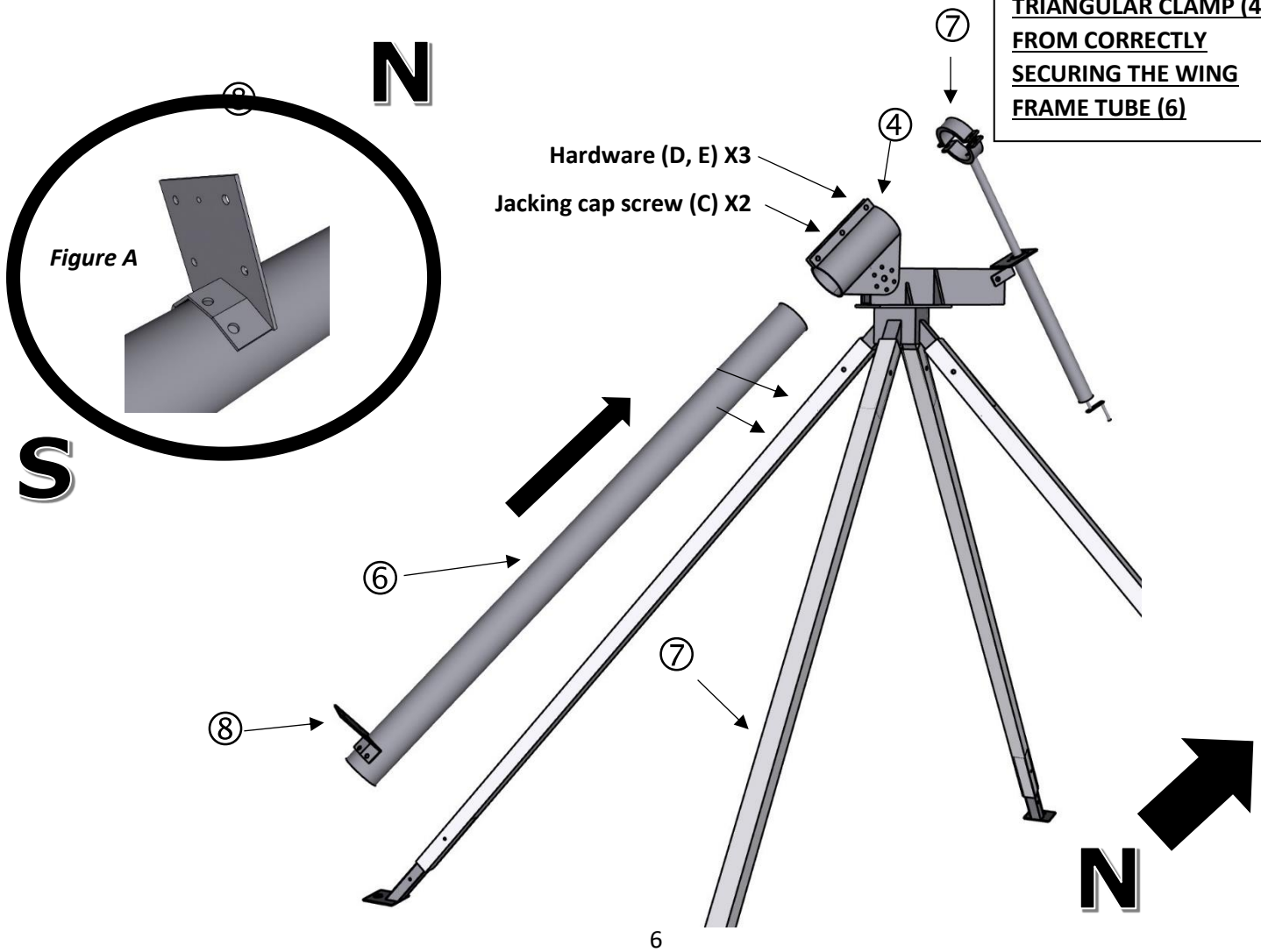

6. Install the **Wing frames (9)** to the lower **Wing mount weldment (8)** with **Hardware (A, B)**. Tighten by hand and then place a straight edge on top to ensure each component is straight before **torquing Hardware (A, B) to 42ft/lbs**. Once Torqued and the Wing assembly is level completely loosen the **Jacking cap screws (C)** and torque **Hardware (D, E) and the Jack clamp (7) Hardware to 64ft/lbs**.

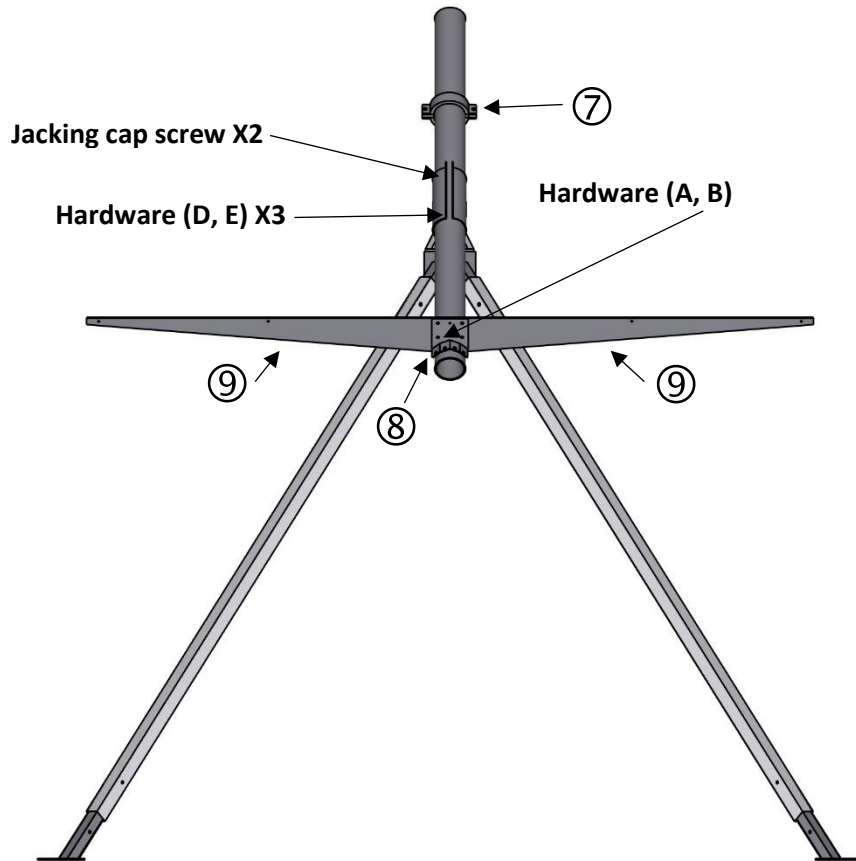

7. Pre-assemble the **Wing mount weldment (8)** and **Wing Frames (9)** on the ground or a bench with **Hardware (A, B)**. Line up the top of the Wing assembly with a straight edge and torque bolts to **42 ft-lbs.**

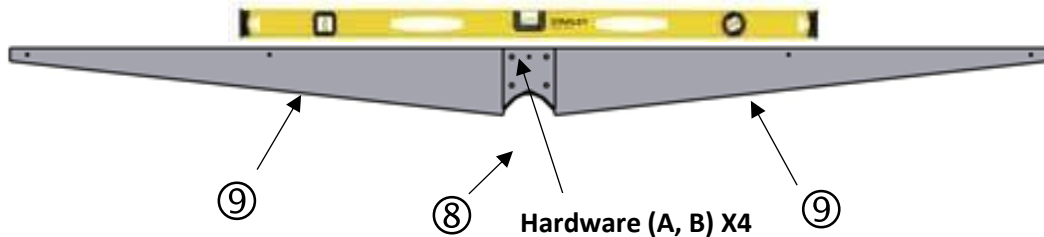

8. Install the top **Wing frame (9)**, **Wing frame weldment (8) assembly** with **Hardware (D, E, F)** place a level on top to find perfect level and **Torque to 42 ft-lbs.** Each Bolt should have a washer on the inside of the **Wing frame tube (6)** and on top of the **Wing mount weldment (8).**

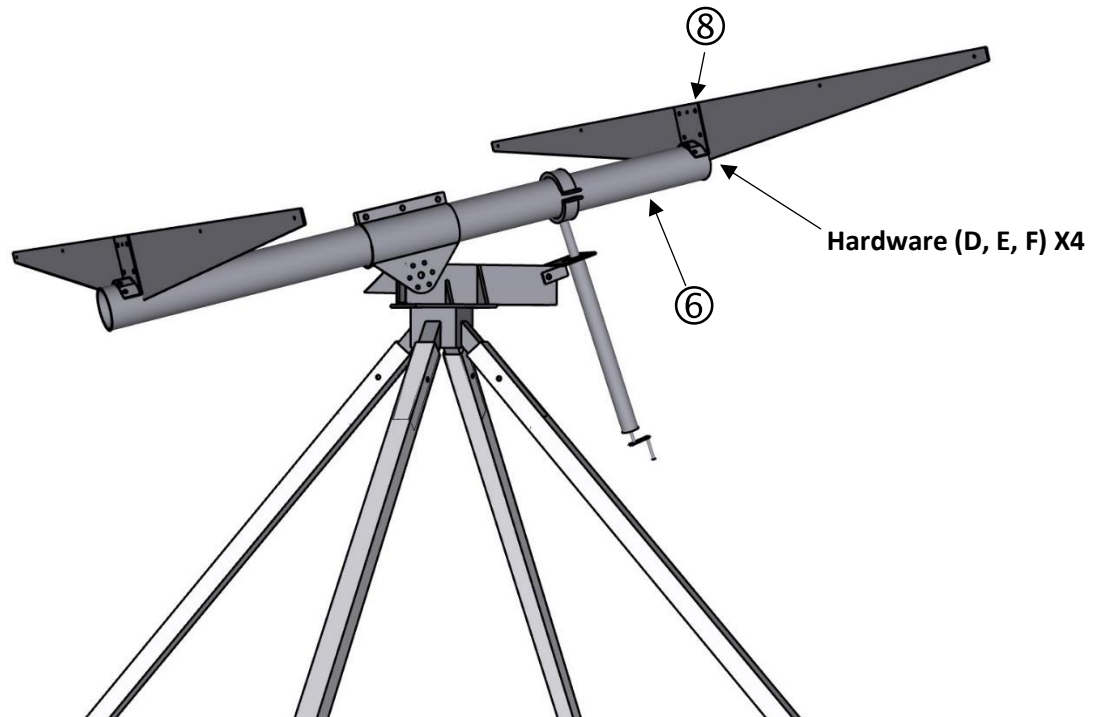

Kinetic rail install guide

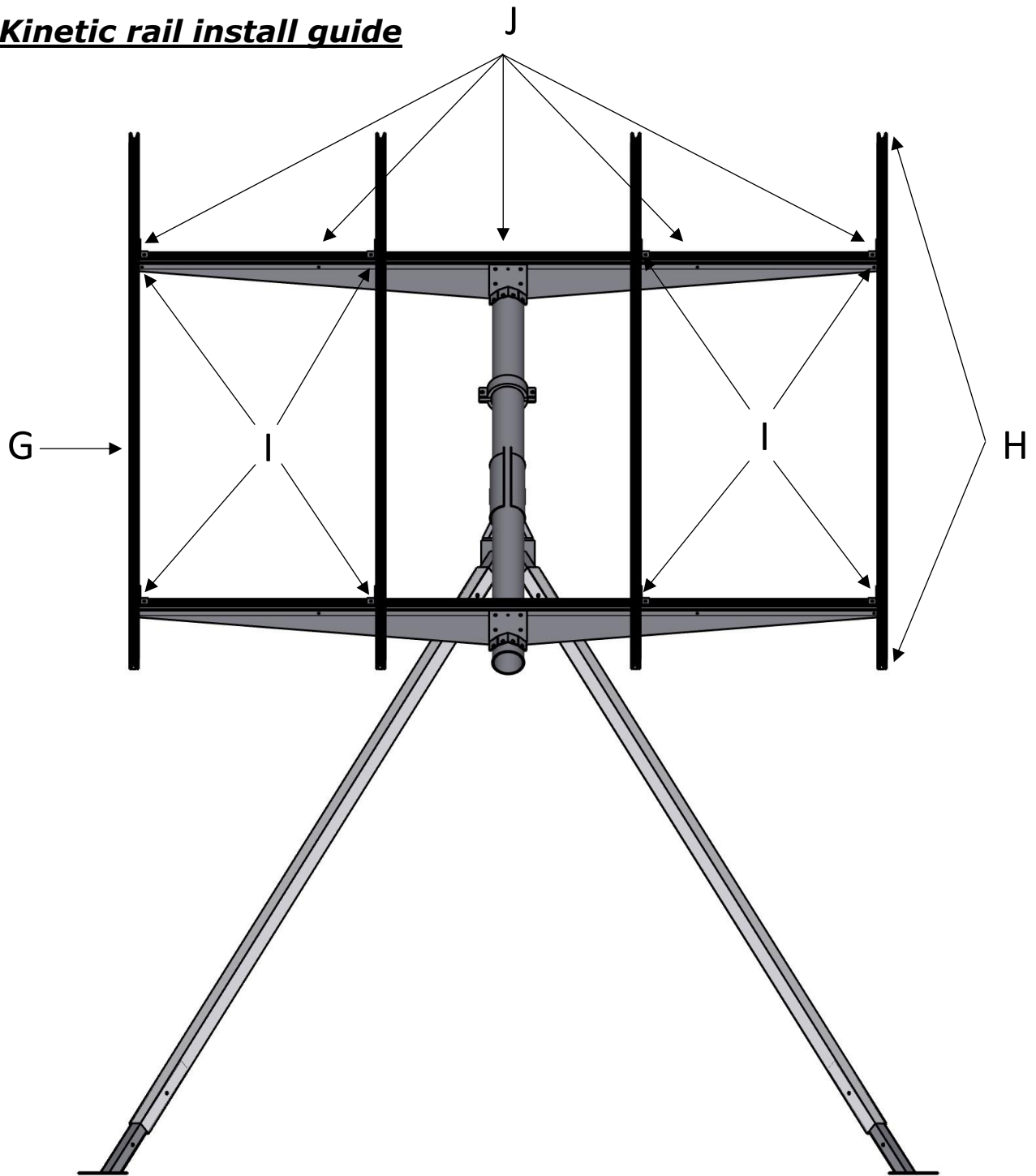

Section 5: Manufacturer's Warranty

Installer/User Responsibilities

The installer is solely responsible for:

Complying with all applicable local or national building codes, including any that may supersede this manual.

Ensuring that Benjamin Mechanical Inc products and other products are appropriate for the installation and the installation environment.

Using only Benjamin Mechanical Inc parts and installer-supplied parts as specified by Benjamin Mechanical Inc. Substitution parts may void the limited warranty.

Ensuring correct and appropriate design parameters are used in determining the design loading used for the specific installation. Parameters, such as snow loading, wind speed, exposure and topographic factors should be confirmed with the local building official or an engineer.

Warranty Information

Benjamin Mechanical Inc warrants each Mounting Structure to be free from defects in materials and workmanship for 1 year from the date of the first purchase ("Warranty Period"), when installed properly and used for the purpose for which it is designed, except for the finish, which shall be free from visible peeling, or cracking or chalking under normal atmospheric conditions for a period of 1 year, from the earliest of 1) the date of installation of the Product is completed, or 2) 30 days after the purchase of the Product by the original Purchaser ("Finish Warranty"). The Finish Warranty does not apply to any chemical or harsh substance deposited on the finish.

Galvanized coated sheet steel components will show rust on cut edges and is normal and will not affect the structure and function of the mount.

The warranty covers the replacement cost of parts to repair the product to proper working condition. Transportation and incidental costs associated with the warranty items are not reimbursable. The warranty does not include normal wear or damage resulting from misuse, abuse, improper installation, negligence, or accident, or sizing errors of the concrete base that will receive the poles or quad pods. The Purchaser must or installer must validate the sizing of the concrete base by an expert or engineer. The warranty does not cover any defect that has not been reported in writing to Benjamin Mechanical Inc within 10 days after discovery of such defect. Furthermore, it does not cover units that have been altered, modified or repaired without authorization from the manufacturer or its representative, or units used in a manner or for a purpose other than that specified by the manufacturer. The warranty will be void if a modification has been made to one or more of the solar support components. Benjamin Mechanical's entire liability and Purchaser's exclusive remedy, whether in contract, tort or otherwise, for any claim related to or arising out of the warranty covering the Mounting Structures shall be correction of defects by repair, replacement or credit, at Benjamin Mechanical's discretion. Refurbished Mounting Structures may be used to repair or replace the Mounting Structures.

Benjamin Mechanical Inc shall not be held liable for any injuries or damages to persons or property resulting from any cause, whatsoever, or any claims or demands brought against Benjamin Mechanical Inc. arising from the improper installation of the Mounting Structures and/or failure to comply with the instructions set out in the Benjamin Mechanical Inc. manual and this warranty by the Purchaser, any employee of Purchaser, client of Purchaser or end-user of the Product or other party. This provision applies to all materials provided by Benjamin Mechanical Inc during and after the Warranty Period.

