

INSTRUCTIONS



MODEL: *Low-Boost SideKick
Agility*

FITS: *2016-2020 Axys 800
2016-2020 Axys 800 SKS*

BoonDocker
Agility

Table of Contents

Contents

<i>INSTRUCTIONS</i>	1
<i>Contents List</i>	3
<i>User Manual</i>	4
<i>Initial Teardown</i>	6
<i>Cooling System</i>	28
<i>Tune Pipe</i>	32
<i>Turbo</i>	38
<i>Turbo / Exhaust</i>	40
<i>Turbo Cooling System</i>	41
<i>Turbo Oil System</i>	45
<i>Turbo / Air Intake</i>	49
<i>Fuel System</i>	52
<i>Charge Air</i>	54
<i>Cold Air</i>	57
<i>Electronics</i>	63
<i>Vents</i>	71
<i>Reassembly</i>	75
<i>Fueling Mode</i>	77
<i>Control Box</i>	78
<i>HAVE FUN</i>	80

Contents List

Thank You
for Buying



Made in the USA

(1) F47 Turbocharger/Muffler Assembly with:

- (1) Bracket w/cotter key
- (1) Air solenoid
- (1) Oil Pump
- Hoses, fittings, hardware

(1) Exhaust Inlet

(1) Charge Air Box w/ Injectors & Bosch Sensor

(1) Charge Tube

(1) Coil Mount Bracket

(1) Cold Air Intake Plenum

(1) Cold Air Intake Tube

(2) Cold Air Intake Vents

(1) Fuel Control Box

INLET KIT BAG

- (4) Long exhaust springs
- (4) 8x25mm SS Hex bolt
- (4) 8mm SS top lock nut
- (4) 8mm SS washer

CHARGE TUBE KIT BAG

- (2) 1.75 x 2.25 Silicon, notched
- (2) #36 Hose Clamp
- (2) T-bolt clamp, notched
- (1) 2.5" Piece of 2" Silicone
- (1) 3.5" Piece of 2" Silicone
- (4) #32 Hose clamps

COLD AIR INTAKE KIT BAG

- (4) 70-90 mm Worm Drive Hose Clamp
- (2) 3" Silicone 90 with Short Leg

OIL LINE KIT BAG

- (1) Clear Oil Line Fitted with 1 Plastic T and 1 Plastic Reducer

MISC

- (10) 8" Zip Ties
- (10) 4" Zip Ties
- (4) 1/4-20 x 3/4" Bolts
- (4) 1/4-20 Nylon Lock Nuts
- (1) Polaris 850 Cross Member Bar

User Manual

GENERAL SAFETY

1. ALWAYS wear your seatbelt (if applicable), helmet, and PPE when operating your vehicle.
2. Clutching, belts, motor, exhaust components and drivetrain may be HOT enough to burn you. Do not touch until vehicle has had sufficient time to cool. Wear proper PPE to prevent burns.
3. Clutching, belts, motor, exhaust components and drivetrain may be sharp. Wear proper PPE to prevent laceration.
4. ALWAYS follow the safety suggestions of your owner's manual.

GENERAL

1. Print entire instruction manual. In the print settings, you can choose to print multiple tiles per page (we suggest 4-6). However, the tunnel-cut-pattern needs to be printed full size.
2. Installation IS YOUR RESPONSIBILITY. During the first ride, take the time to pull over, OFTEN, and check for excess heat, leaks, rubbing wires, and general installation fit and completion. BoonDocker does not cover or warranty parts against melting. We strongly recommend venting and heat-shielding as necessary. These items may not be included in the kit, but are YOUR RESPONSIBILITY!

OPERATION

1. ALWAYS allow your vehicle to reach proper operating temperatures before driving. Refer to your owners manual.
2. Your Polaris comes with ECU-programmed "break-in". During this time, your SideKick may not perform at the optimum level. Once break-in is complete, you will likely notice more power and cleaner engine performance. During break-in, expect your snowmobile to run rich.
3. Because of excessive oiling, during break-in mode, you will need to replace your plugs more frequently. After break-in mode, replace plugs AT LEAST every 500 miles for maximum performance.
4. The SideKick turbo kit is a HIGH PERFORMANCE accessory. Proper fuel and maintenance is critical (see "FUEL")
5. High performance machines are more prone to belt failure. ALWAYS carry a spare belt, and understand how to change/replace your belt BEFORE you get out in the field. Properly inspect your belt and clean your clutches before each ride.
6. ANY "DET" or Detonation codes are not acceptable. If you get a DET code during normal operation, you likely have bad gas. Drain all of the fuel, and replace with fresh fuel from a different source. If the problem continues, immediately contact your dealer.
7. SideKick is calibrated for operation above 5,000 feet. Use below that elevation is at your own risk.
8. Check coolant levels after the first 10 minutes of operation. Coolant system may need to be bled.
9. Run your sled in "PREMIUM" mode. Switching to "ETHANOL" mode will make the vehicle run Richer (approx. 7% richer). Some sleds/fuel may require "ETHANOL" mode for a richer running condition. ONLY run "ETHANOL" mode if instructed. Refer to your owners manual to correctly configure your vehicle. DO NOT connect the "Map Jumper" unless instructed by BoonDocker.



User Manual

FUEL

1. The SideKick is a HIGH PERFORMANCE accessory. Proper fuel is critical.
2. ALL KITS are initially calibrated for a 50/50 mix from BoonDocker. Using any other blend or straight pump gas may cause engine failure.
3. 50/50 Mix tunes require an exact 50% mix of 91-octane (up to 10% ethanol, and 50% 100LL Av-Gas. Using a 50/50 mix of 91/110 race gas is also acceptable.
4. When available (coming soon for Patriot 850) - Pump Gas tunes REQUIRE 91-octane fuel (or higher). Non-ethanol fuel is recommended. DO NOT use fuel with >10% Ethanol. If you're concerned about the quality of pump fuel, mix NO MORE than 15% Av-Gas. Using higher octane than required will cause poor performance.
5. When available (coming soon for Patriot 850) - AV-Gas tunes REQUIRE 100LL (or higher), Av-Gas tunes: INTERCOOLER REQUIRED.
6. USE ONLY THE FUEL DESIGNED FOR YOUR KIT!
7. Fuel degrades with time. Fuel stored in plastic containers should be used within two weeks. Fuel in the tank of your vehicle will also degrade. DO NOT run fuel from any previous season or extended period of non-operation. .
8. Operating your vehicle with old/degraded fuel may cause engine failure
9. Operating your vehicle with the incorrect fuel for your tune may cause engine failure.

CLUTCHING & CLUTCH MAINTENANCE

1. A primary-clutch puller is REQUIRED for clutching installation. If you do not have one, you can have your dealer install the clutching. BoonDocker sells clutch pullers, and most dealerships also stock them, some even rent them.
2. Our clutching is engineered and validated for the SideKick. Using other clutching may cause a loss of performance, and is not supported or suggested.
3. Clutch springs wear out over time. We suggest replacing clutch springs every 500 miles.
4. Clutch maintenance is CRITICAL on high performance machines. We suggest you clean your clutches after each ride: Remove the belt. Use compressed air to blow any remaining debris from the clutch internals. Use a red scotch-brite pad to loosen any rubber/debris from the clutch-sheave faces. Dampen a rag with acetone and wipe the clutch sheave faces. Inspect belt for damage and/or wear.
5. Weights may ship pre-loaded, or may be blank. Load weights 2-3-3-2 (from heel to toe). Total weight should be approximately 73g per weight for 50/50 SideKick.
6. Any clutch-weight modification MUST be done to all three weights in unison. DO NOT run unbalanced weights. Additionally, the magnets are polar. To change weighting, pull ALL magnets from the weights (all holes), align in a stack, and repopulate weights with magnets to preserve polarity. DO NOT just add one weight without preserving polarity of the entire magazine of weights. Failure to preserve polarity will lead to magnets being 'thrown' from weights and potential clutch damage and/or personal injury.
7. Turbocharged Polaris Patriots are expected to turn 8550 +/- 100 RPM's. Use provided adjustable weights to keep RPMs at recommended levels.
8. Adjusting peak RPM is possible by adding/removing weight from the toe.
9. It is possible for magnets to be ejected from weights if they're not properly seated. We suggest using a small amount of glue as a precautionary measure.

Initial Teardown



Verify kit contents against included contents list.

DO NOT lift turbo assembly by the plastic bag. Carefully remove turbo assembly from bag to avoid dropping and/or damaging turbo assembly!

READ THE ENTIRE INSTRUCTION PACKET BEFORE PROCEEDING!

Remove hood and side panels. To remove hood, disconnect dash/headlight harness at connector, located on the mag side, near the overstructure/on top of air-box.

Initial Teardown



Remove "dart" fasteners from console B. Remove Torx fasteners from airbox assembly C. Repeat on both sides. Cut the zip tie holding the EGT & Hood Harness.

Initial Teardown



Lightly pull the rope handle to allow slack. With console piece slightly pulled back, disconnect the wiring harness for the console switches, located on the back side of the console. Slide console piece behind rear of seat and secure as shown.

Initial Teardown



Use OEM provided clutch-tool to spread sheaves on secondary and remove belt. Remove secondary clutch.

NOTE: There are washers/spacers behind the secondary clutch. These may “stick” to the secondary clutch. Do not lose or misplace them. Keep note of their orientation.

Initial Teardown



Disconnect level-sensor wire harness from oil tank. Remove bolts that secure oil tank/clutch guard to the snowmobile. Slide tank/guard out of location and secure (oil feed line remains attached)

DO NOT allow oil tank to drop.

Initial Teardown



Remove rear fasteners from stock air intake.

Initial Teardown



Disconnect OBDI port from airbox plenum and cut Zip-Tie B. Leave the grey fastener. Remove both fabric-covered stock air intake plenum (not reused) C. Save plastic dart-fasteners for later use.

Initial Teardown



Disconnect ECU wiring harnesses by pressing the release tab(s) and gently pulling down on harness to prevent wire fatigue. Unbolt ECU from air intake/overstructure and set aside for future use.

Initial Teardown



Remove air intake fasteners

Initial Teardown



Remove wire-harness fastener (loom dart) from air intake. Remove and set aside air intake to prep for assembly and for ease of access.

Initial Teardown



Remove stock TBAP sensor from stock air-box.

Initial Teardown



Loosen throttle body clamps (prepare to remove airbox)

Initial Teardown



Unbolt the two coils from stock air-box

Initial Teardown



Cut zip-tie as shown to free wire harness from stock air-box

Initial Teardown



Remove stock air-box as shown (not reused). Use caution to avoid stress to wire harness.

Initial Teardown



Prevent any foreign-object contamination by blocking off throttle bodies.

DO NOT USE any rag or towel that will shed particulates. DO NOT USE a rag or towel that is dirty or can shed debris.

Initial Teardown



Remove exhaust springs from muffler assembly

Initial Teardown



Cut the Zip-Tie to allow you to unplug the factory muffler-temp sensor. Unplug sensor from harness. Leave stock muffler-temp sensor probe installed in muffler (this part is not re-used with turbo installation). Remove muffler assembly from snowmobile.

Initial Teardown



Plug supplied resistor into harness, directly in place of factory muffler temp-sensor. Resistor is packaged with the control box and electronics.

Initial Teardown



Drill out rivets to remove jack-shaft guard. Remove jack-shaft guard. Clean up debris.

Initial Teardown



Remove Axys 800 Muffler support brace.

Initial Teardown



Install Axys 850 muffler support brace provided in kit.

Cooling System



Use hose-pinch tool to block off coolant line to throttle bodies on PTO side to prevent back-feeding while draining coolant bottle.

Cooling System



Loosen tension clamp on outer barb of coolant bottle as shown. Have catch container available to contain coolant spillage. Drain fluid from coolant bottle. Use hose-pinch tool to prevent coolant from spilling out of coolant line.

NOTE: Vapor lock may prevent coolant from escaping coolant bottle. Crack the lid of the coolant bottle, once you have a catch-pan in place, to relieve vacuum.

NOTE: There is a baffle inside the bottle, so you cannot siphon coolant out.

Cooling System



Remove hose-pinch tool and drain coolant from line that runs to MAG-side of throttle bodies.

Cooling System



Set aside coolant to reuse. Remove coolant hose and clamps (running from PTO-side of throttle bodies to coolant bottle). Clamps are used in future steps. (Hose is not reused).

Tune Pipe



REMOVE PIPE: Remove EGT probe from pipe to allow working space. Remove exhaust springs and factory pipe. Take care to preserve exhaust graphoil gasket.

Tune Pipe



Inspect graphoil gasket. Replace if necessary. Use high-temp silicon to coat the outer surface of the graphoil gasket.

Tune Pipe



Reinstall graphoil gasket using alignment tab on Y-pipe.

Tune Pipe



Use high-temp silicon to coat the inner surface of the factory pipe, on the motor-side.

Tune Pipe



Reinstall factory pipe. Use factory AND supplied (short) gold exhaust springs to “double-up” springs.
Reinstall factory EGT probe into pipe.

Tune Pipe



Inspect graphoil gasket (between factory pipe and muffler). Replace if necessary. Apply high-temp silicon to graphoil gasket and slide onto pipe. Apply high-temp silicon to inner-surface of supplied exhaust inlet in preparation for installation.

Turbo



Route coolant lines towards the front of the turbo. Allow turbo bracket to seat on rubber isolator and chassis cross-member. Use supplied cotter-key to secure the front of the turbo bracket

NOTE: Verify the rubber isolator is properly seated in the chassis-saddle. Your isolator MAY have stuck to the muffler during teardown. Verify the window on the isolator is properly oriented with the chassis topography

Turbo



Use supplied cotter-key to secure the back of the turbo bracket

Turbo / Exhaust



Apply silicone to inside of inlet bell, install using supplied bolts (with washers underneath turbo flange on nut side) and gold long springs to fasten inlet onto tune pipe.

Turbo Cooling System



Route coolant lines following the factory coolant house and down the backside ensuring coolant lines avoid pull-rope.

Turbo Cooling System



Install coolant hose to coolant bottle and tighten hose clamp.

Turbo Cooling System



Install coolant hose to throttle body and tighten hose clamp

Turbo Cooling System



Refill coolant bottle with saved coolant and top off as needed.

Turbo Oil System



Set oil tank on top of clutches so that the nipple is facing directly up and unplug the stock oil line. Install the provided oil line and re-install stock line to the bottom of the T.

Turbo Oil System



Route oil line along the top of the injector harness and zip tie in place.

Turbo Oil System



Remove the red plug in the gray oil line leading to the turbo.
Re-install oil tank into upright position allowing oil to purge the line. Connect the clear plastic line to the gray oil pump line once system is perged. Verify the oil lines are free of air.

NOTE: oil CANNOT be pushed through the pump but it can be pulled through the pump with a suction device.

!WARNING!

FAILURE TO PURGE
AIR FROM OIL LINES
WILL
RESULT IN
TURBO DAMAGE
DO NOT
PROCEED WITH
INSTALL UNTIL OIL
LINES ARE FREE OF
AIR

Turbo / Air Intake



Loosely install T-bolt clamps to notched silicon fittings as shown.

Turbo / Air Intake



Install fittings to throttle bodies. Verify notches on clamps and fittings are in alignment with tabs on throttle bodies.

CRITICAL: Verify clamps and silicone has complete seated. Trim clamps if necessary for fit.

NOTE: PTO-side has only one (1) tab utilizing slots in fitting/clamp. MAG-side will utilize both slots.

Turbo / Air Intake

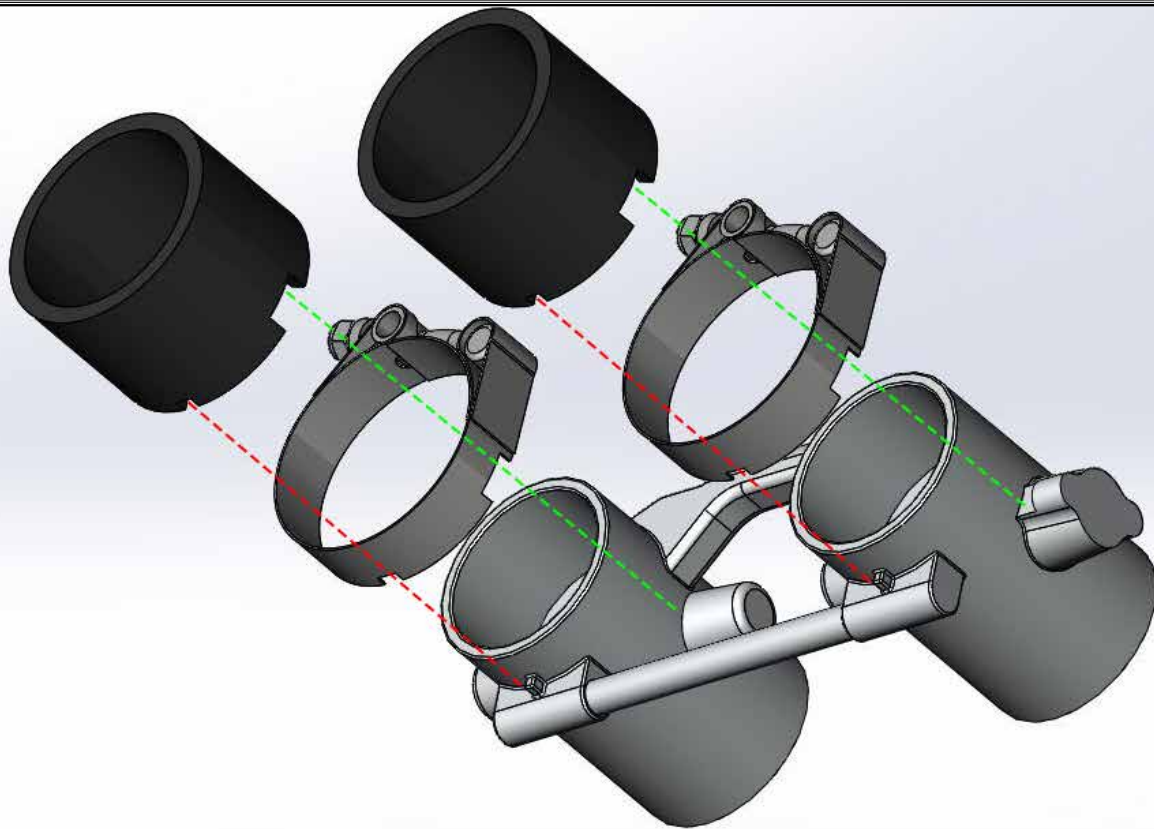

THROTTLE BODY VIEW (BOTTOM, LOOKING UP)

View showing clamp & fitting alignment on the throttle bodies

Fuel System



Install BoonDocker airbox. Secure by tightening hose clamps. Verify routing of auxiliary injector hoses: Auxiliary injector hoses should run along back side of airbox, and wrap around to factory fuel plugs without kink(s). Unplug fuel-sending line B (green). Install auxiliary injector connection in-line. Remove foam line-isolator C.

Fuel System



Verify routing of fuel lines. Secure with Zip Tie as shown B. Verify clearance of fuel lines by turning skis each direction (check clearance of pitman arm and steering rod).

Charge Air



Install short charge tube silicone as shown.

NOTE: *Loosely install hose clamps to allow for easy adjustment/fit for next steps.*

Charge Air



Install charge-air intake tube using supplied silicone and connect to silicone installed in previous step.

Once fittings & tubes are properly seated with acceptable clearance, tighten all clamps.

Charge Air



Install boost reference line, from charge-air intake tube to air-solenoid on turbo bracket.

Secure with Zip Tie B to prevent boost reference line from disconnecting from barb

Cold Air



Lift factory air-collector off sled. Slide provided cold-air intake plenum onto factory air collector. Mark and drill hole using 5/16 drill bit. Remove supplied cold-air plenum for additional pre-assembly.

Cold Air



Measure down 2 3/4" from air collector box seam and align with the CENTER of the stock hole. Mark and drill 1/2" hole. Reinstall provided cold air intake plenum and fasten with push-darts (two darts from stock intake plenum, and one provided with kit).

IMPORTANT: Prior to installing cold-air intake plenum, make sure ALL debris from drilling has been removed from cold-air intake collector box. Debris can damage turbo components.

Cold Air



Install TBAP sensor by pushing probe through 1/2" hole drilled previously. Use original screw to fasten TBAP sensor.

NOTE: DO NOT OVER TIGHTEN

Cold Air



Install coils onto supplied coil bracket. Coils go in the bracket with wires facing towards nose.

NOTE: MAG goes on bottom, PTO goes on top

Cold Air



Reinstall cold air intake assembly as shown.

Cold Air



Using stock hardware, install ECU and coil mount bracket. Bracket goes behind the ECU, with the coils angling inward. Use supplied velcro between ECU and coil bracket to prevent vibrations and to stabilize ECU / bracket.

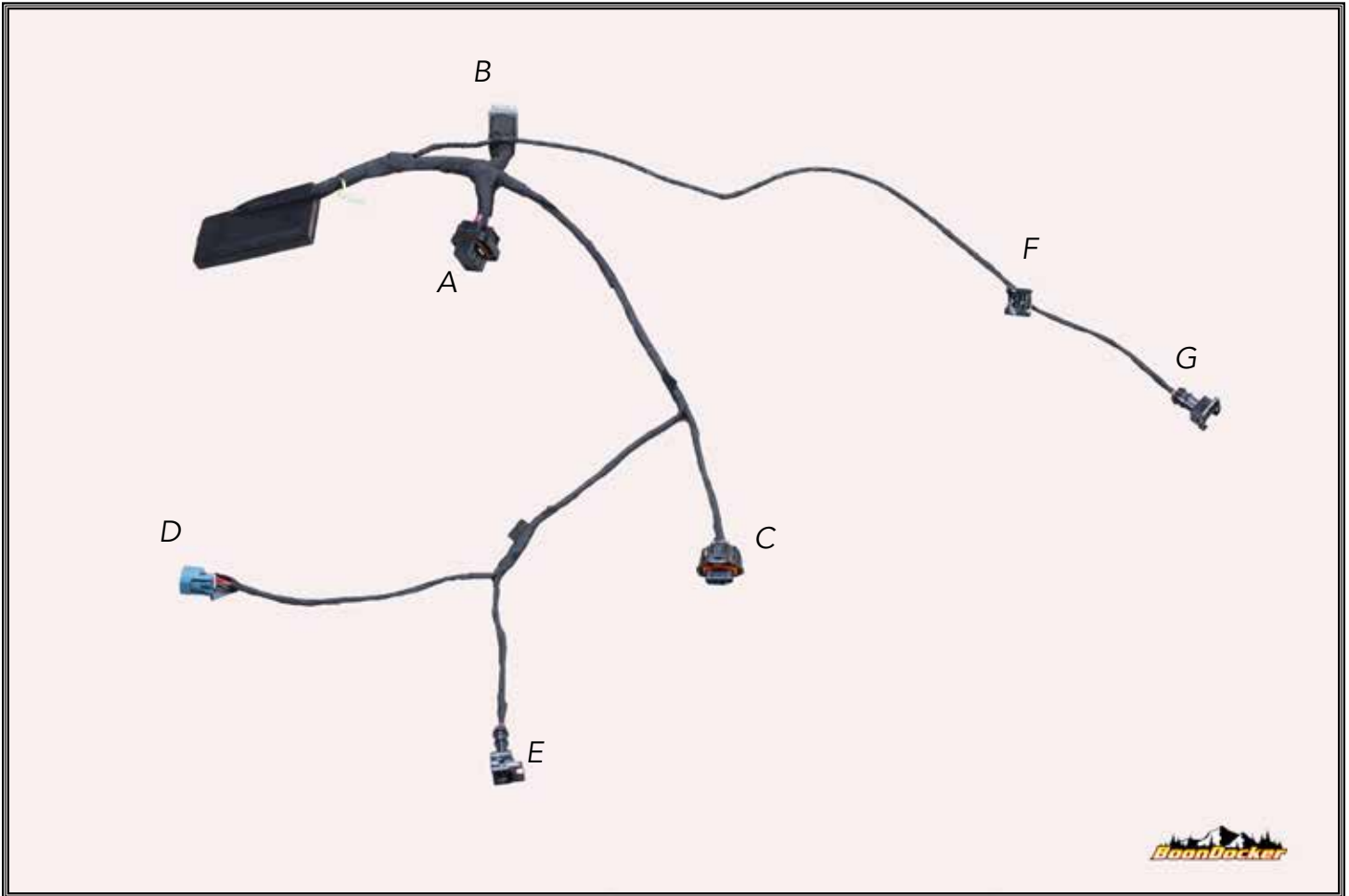

WIRING DIAGRAM:

- A) Factory ECU
- B) Factory ECU wire harness
- C) Boost sensor on airbox
- D) Oil pump on turb
- E) Boost solenoid on turbo
- F) PTO side auxillary injector
- G) MAG side auxillary injector

Electronics



Plug the BoonDocker Fuel Controller directly into the ECU and velcro controller to the ECU as shown.

Electronics



Connect the stock ECU plug into the fuel controller, and zip tie as shown.

Electronics



Connect ground eyelet, coming from fuel controller to the common ground bolt located on the front bumper mount.

Electronics

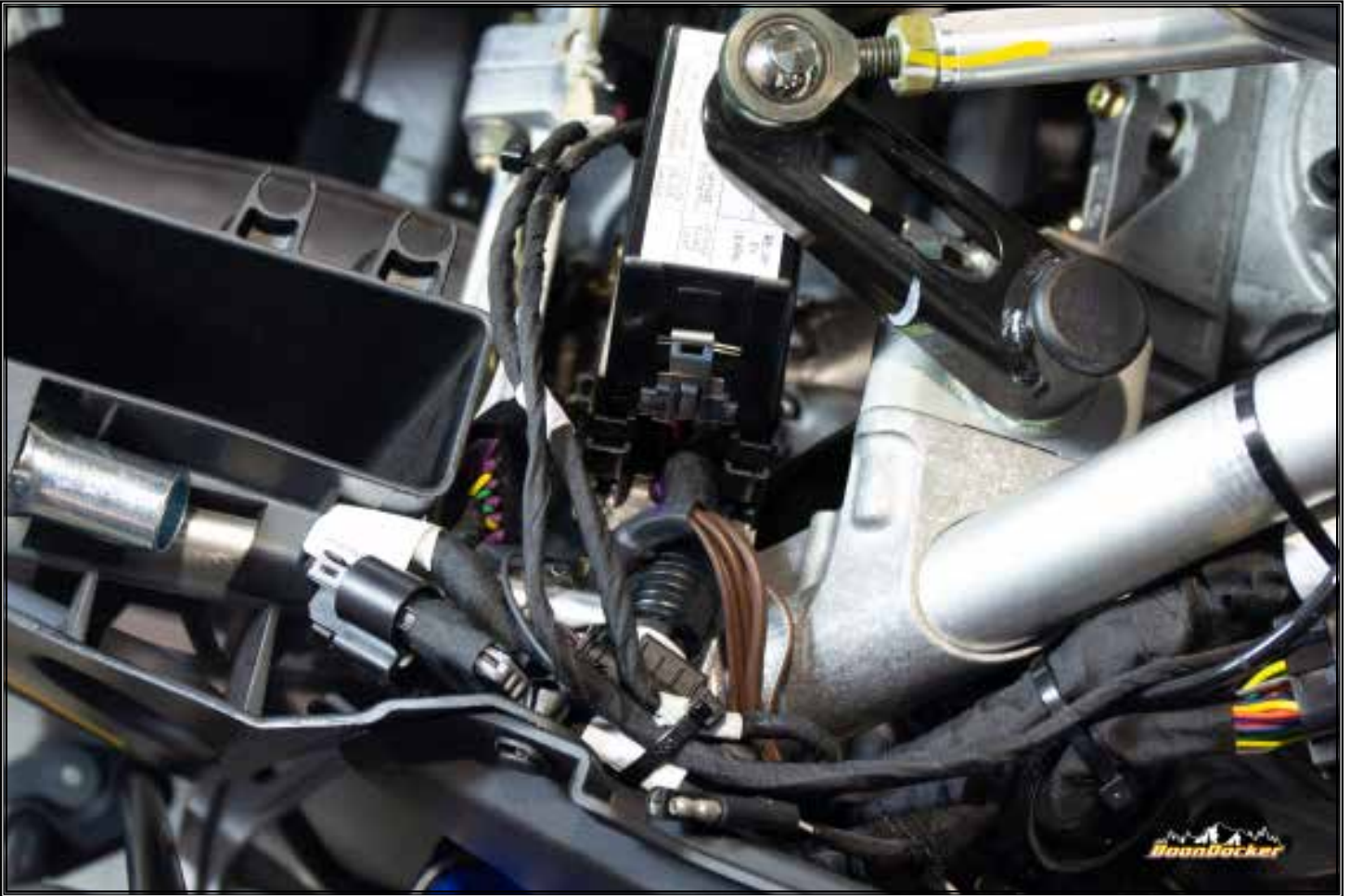

Cut zip ties and route the factory exhaust valve wire harness up near front bumper mount and plug into the fuel controller wiring harness. Route the fuel controller exhaust valve harness to the exhaust valves', zip tying same as stock.

Electronics

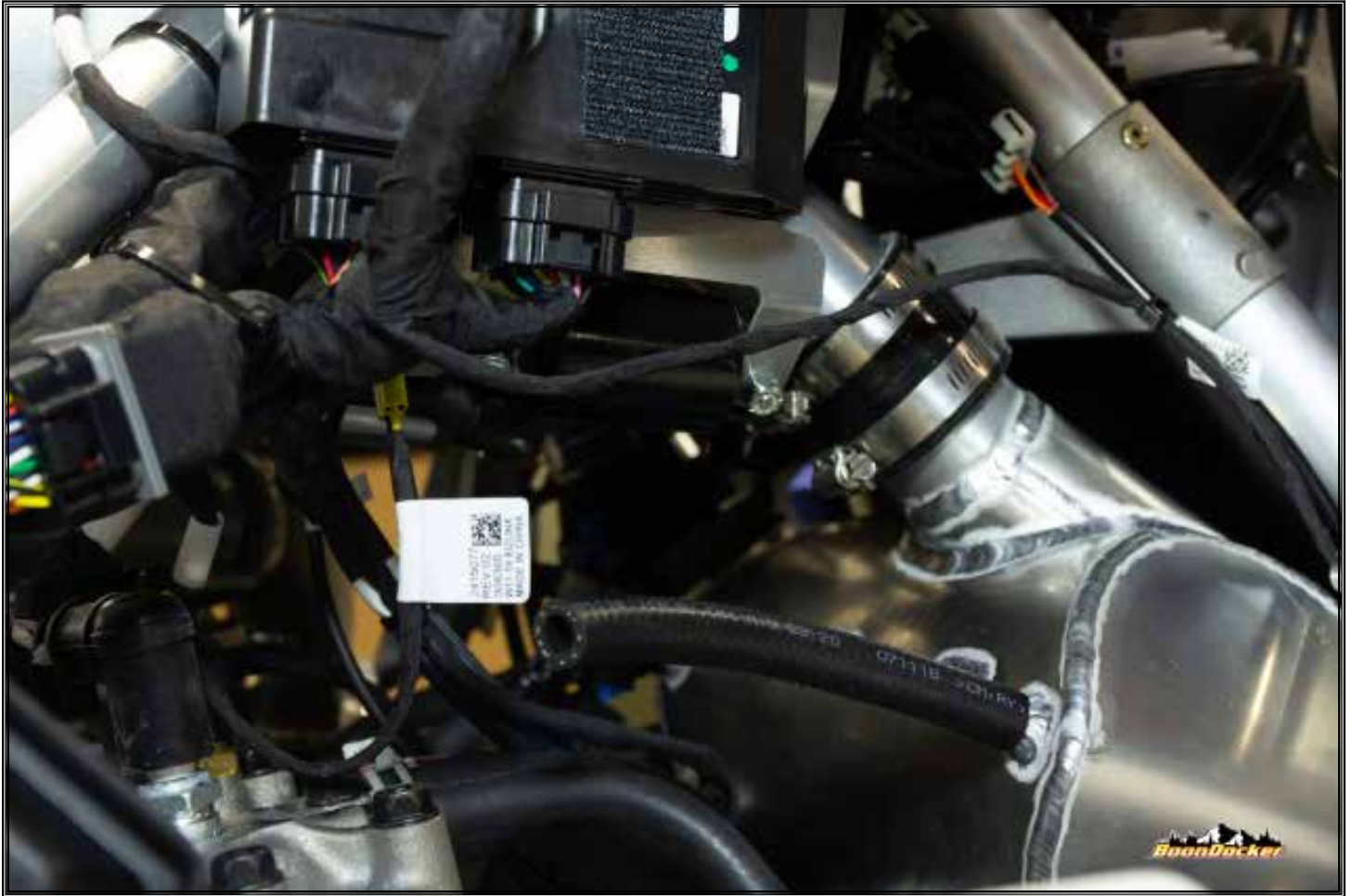

Route the auxillary fuel injector harness and zip tie as shown

Electronics



Plug auxillary fuel injector harness into fuel injectors and zip tie as shown.

Electronics



Route boost solenoid, boost sensor and oil pump wire harness and zip tie as shown.

Plug all connectors into their corresponding componets.

Vents



Re-install gas tank shroud. Ensure tab B correctly seats into groove on factory air intake box.

Vents



We recommend removing the stock vents to maximize air flow, however you can leave them in place.

Vents



Push BoonDocker deep snow vent onto factory air intake box insuring the locking tab is slid into its' notch and the vent sits tightly around every edge.

Vents



Screw vents to factory air intake box with provided black phillips screws.

Reassembly



Install cold-air intake silicone and tubing. Tighten clamps.

Reassembly



Reinstall hood and plastics. Don't forget to plug in gauge harness

Fueling Mode



Configure your snowmobile for "Premium Mode" using your gauge. Refer to your owners manual or: "<http://www.polaris.com/en-us/rider-support/owners-manual>" to properly configure the fuel mode.

NOTE: PIDD and Standard Gauge will have different instructions

Control Box

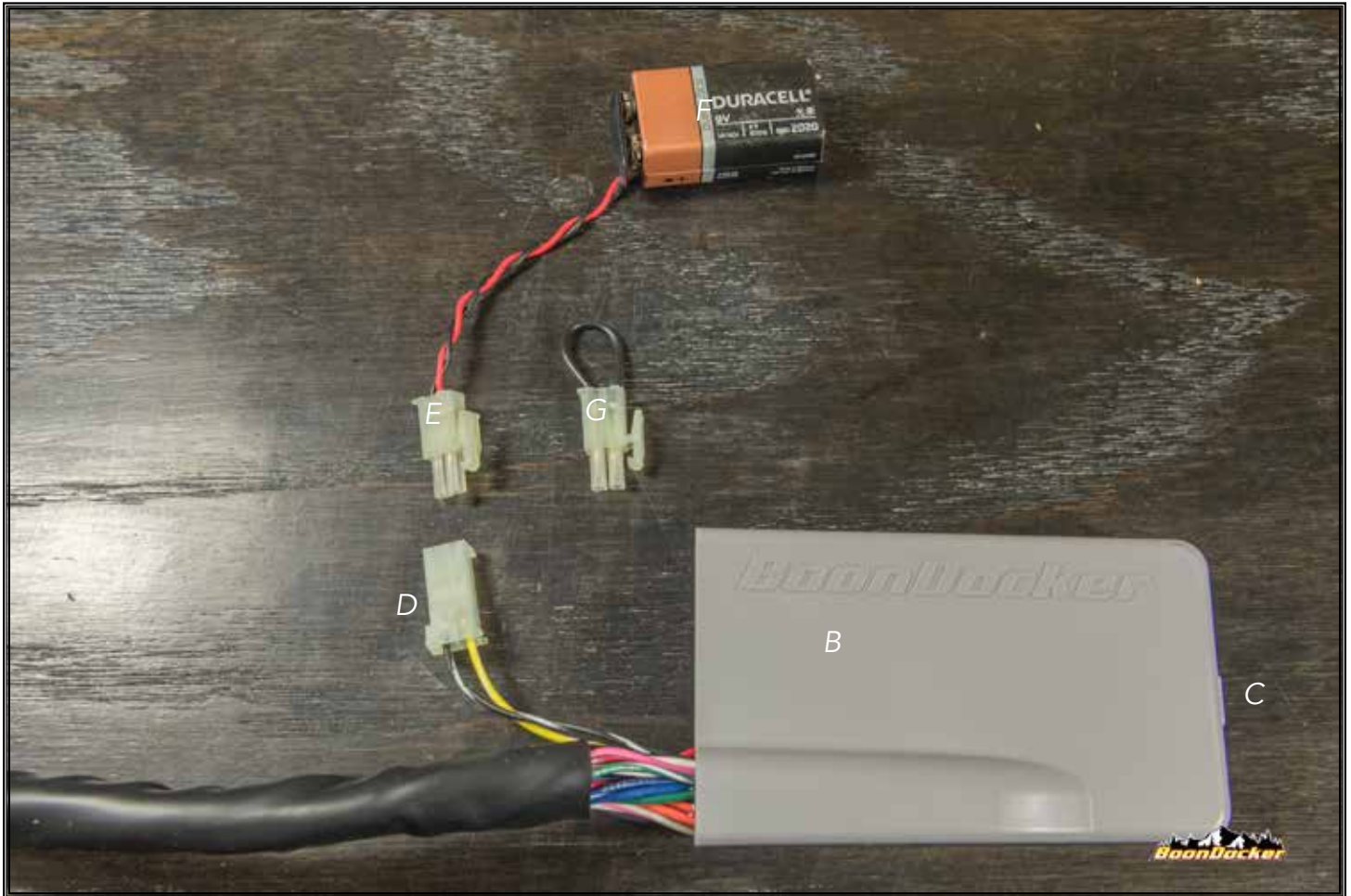

B Control Box

C USB "Update" Port (Micro-USB cable not included, required for update installation)

D Control Box "Jumper" port

E "Battery Power" Jumper (required for update installation)

F 9V Battery (not included, required for update installation)

G "Map" Jumper (leave unplugged, unless instructed by BoonDocker)

NOTE: During normal operation, nothing should be plugged into the D Jumper port, unless specifically requested by BoonDocker.

Control Box

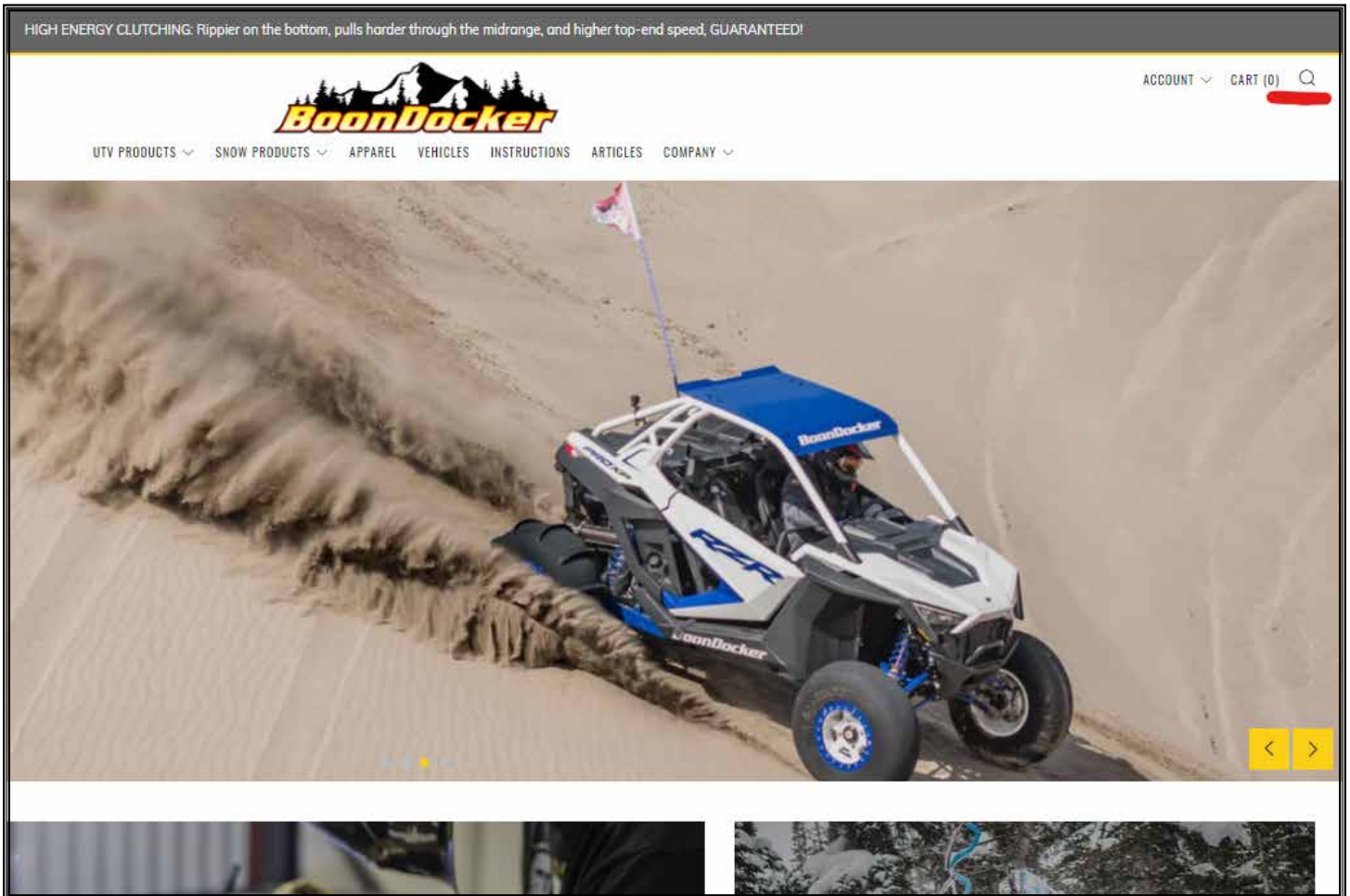

UPDATING your control box is required! DO NOT RUN your snowmobile without first updating your control box.

UPDATE YOUR CONTROL BOX: Please refer to Control Box Update Instructions, available at <http://boondockers.com/> and search "tunes". Another set of instructions are available for the full update under your appropriate tuner.

HAVE FUN



Performing this installation is at your own risk. These instructions act as a general guideline, and may not include some steps. As the installer, YOU take responsibility for the entirety of the installation. YOU must ensure proper routing, fitment, shielding, etc to prevent melted parts, chaffed wires, poor performance, etc. Improper installation, of any type, is not covered as a defect under any warranty, implied or written.