



*Fire
Solutions*

**COMPLETE SOLUTION FOR
FIRE PROTECTION SYSTEM VALVE**





Fire
Solutions

COMPANY PROFILE

Arita Fire Solutions offers complete range of firefighting products and equipment with world class quality assuring dependable performance of property loss prevention system under the toughest conditions.

Arita Valve (Houston) Inc. is located in Texas, USA. We are extremely prudent of our product quality with profound understanding of their roles in our customers' safety system. Our manufacturing facilities strictly comply with UL and FM approval standards. We ensure the highest standard is achieved by conducting 100% zero omission of various tests on every piece of products sent out from our plants. We unceasingly innovate product design aspire to achieve higher reliability and continuity of our products.

Arita Fire Solutions stands by its brand reputation in delivering technical integrity, trustworthy quality and reliable performance worldwide.

QUALIFICATION





Gate Valve

Indicator Post - Underground Type

AFF-UIP-G38

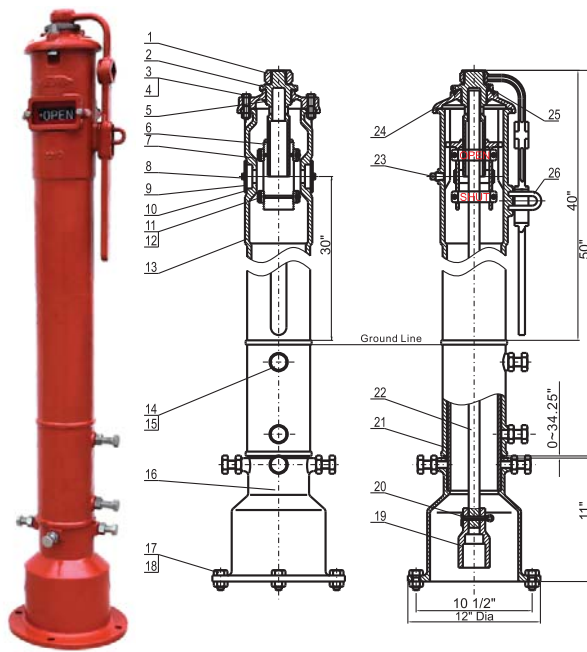

Materials List

DET	QTY.	Description	Material
1	1	Locking Wrench	ASTMA126B
2	1	Operating Nut	ASTM B62
3	2	Hex Nut Screw	ASTMA105
4	2	Hex Nut	ASTMA105
5	1	Snap Ring	AISI A606
6	1	Target Carrier Nut	ASTM B62
7	4	Target	ASTM B108
8	4	Hex Cap Screw	ASTMA105
9	2	Window Glass	LEXAN-UM
10	2	Window Glass Gasket	PTFE
11	4	Hex Cap Screw	ASTMA105
12	4	Hex Nut	ASTMA105
13	1	Body	ASTMA536
14	6	Hex Cap Screw	ASTMA105
15	6	Hex Nut	ASTMA105
16	1	Base Flange	ASTMA126B
17	4	Hex Cap Screw	ASTMA105
18	4	Hex Nut	ASTMA105
19	1	Crane Coupling	ASTMA536
20	1	Cotter Pin	AISI 304
21	1	Stand Pipe	ASTMA53
22	1	Stem	AISI 1045
23	1	Plug	AISI 304
24	1	Cover	ASTMA126B
25	1	Cross Recessed Countersunk Head Screw	AISI 304
26	1	Locking Nose	ASTM 307 B

Field Adjustment:

1. Remove the top section from the top of the Indicator Post assembly.
2. Cut the required length off the bottom of the Standpipe for the Ground Line to match up with Standpipe Ground Line mark.
3. Set the "OPEN" and "SHUT" targets for the appropriate valve size.
4. Reattach the Top Section to the top of the Indicator Post assembly.
5. Design and dimensions are subject to change without notice

Gate Valve

Indicator Post - Wall Type

AFF-WIP-W38

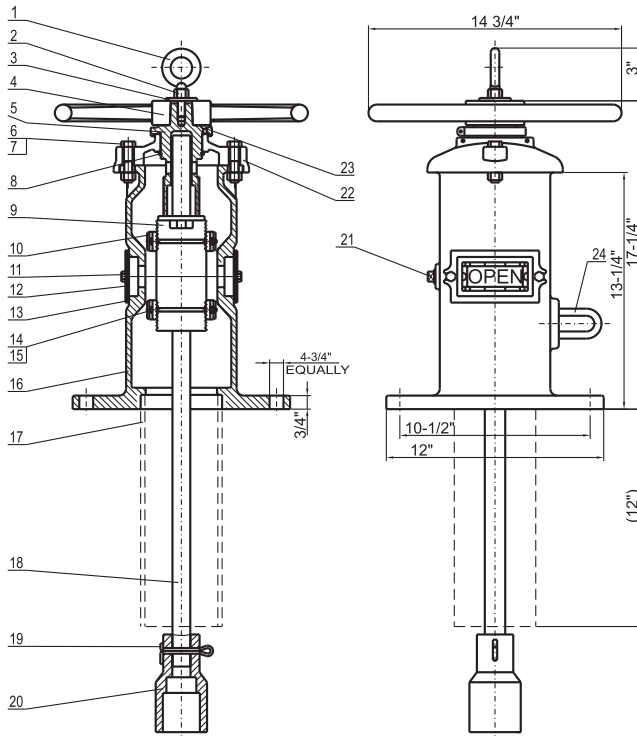

Field Adjustment:

1. Remove the top section from the top of the Indicator Post assembly.
2. Set the "OPEN" and "SHUT" targets for the appropriate valves size.
3. Reattach the Top Section to the top of the Indicator Post assembly.
4. Design and materials are subject to change without notice.

Materials List

DET	QTY.	Description	Material	DET	QTY.	Description	Material
1	1	Lifting Eyebolt	ASTMA105	13	2	Window Glass Gasket	PTFE
2	1	Hex Nut	ASTMA105	14	4	Hex Cap Screw	ASTMA105
3	1	Washer	ASTMA105	15	4	Hex Nut	ASTMA105
4	1	Hand Wheel	ASTMA536	16	1	Body	ASTMA536
5	1	Operating Nut	ASTM B62	17	1	Stand Pipe	ASTMA53
6	2	Hex Cap Screw	ASTMA105	18	1	Stem	AISI 1045
7	2	Hex Nut	ASTMA105	19	1	Cotter Pin	AISI 304
8	1	Snap Ring	AISI A606	20	1	Crane Coupling	ASTMA536
9	1	Target Carrier Nut	ASTM B62	21	1	Plug	AISI 304
10	4	Target	ASTM B108	22	1	Cover	ASTMA126B
11	4	Hex Cap Screw	ASTMA105			Cross Recessed	
12	2	Window Glass	LEXAN-UM	23	1	Countersunk Head Screw	AISI 304
				24	1	Locking Nose	ASTMA307B

Gate Valve

Resilient Seated NRS Type-Flanged Ends

AFF-NGA-32FF-300
AFF-NGA-32FF-250
AFF-NGA-32FF-200

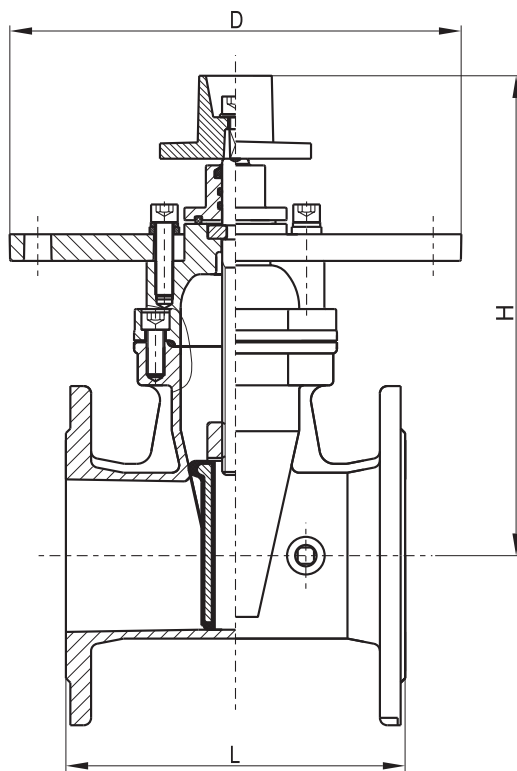

Valve Standard

Conforms to AWWA C515 / BS5163

Working pressure

200PSI / 250PSI / 300PSI

Connection Ends

ANSI B16.1 CLASS125/150
EN1092-2 PN16

Materials List

Part Name	Material	Specification
Body	Ductile Iron	A536 65-45-12
Wedge Disc	Ductile Iron EPDM Coated	
Disc Nut	Bronze	ASTM B62
Stem	Stainless Steel	AISI 304/302
Gasket	EPDM	Commercial
Bonnet	Ductile Iron	A536 65-45-12
Thrust Collar	Bronze	ASTM B62
Gland	Ductile Iron	A536 65-45-12
Wrench Nut	Ductile Iron	A536 65-45-12
Post Plate	Ductile Iron	A536 65-45-12

Dimensions(mm/inch):

SIZE	mm	50	65	80	100	125	150	200	250	300
	inch	2	2 1/2	3	4	5	6	8	10	12
L	mm	178	191	203	229	254	267	292	330	356
	inch	7.00	7.50	8.00	9.00	10.00	10.50	11.50	13.00	14.00
H	mm	279	279	305	324	394	428	537	640	723
	inch	10.98	10.98	12.01	12.76	15.51	16.85	21.14	25.20	28.46
D	mm	305	305	305	305	305	305	305	305	305
	inch	12.01	12.01	12.01	12.01	12.01	12.01	12.01	12.01	12.01



Gate Valve

Resilient Seated NRS Type-Flanged Ends

AFF-NGA-32FF-250(DN350-DN450)
AFF-NGA-32FF-200(DN500-DN600)

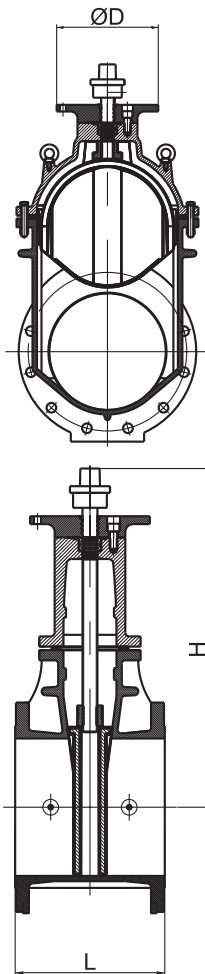

Valve Standard

Conforms to AWWA C515 / BS5163

Working pressure

200PSI / 250PSI

Connection Ends

ANSI B16.1 Class125/150
EN1092-2 PN16

Materials List

Part Name	Material	Specification
Body	Ductile Iron	A536 65-45-12
Wedge Disc	Ductile Iron EPDM Coated	
Disc Nut	Bronze	ASTM B62
Stem	Stainless Steel	AISI 304/302
Gasket	EPDM	Commercial
Bonnet	Ductile Iron	A536 65-45-12
Thrust Collar	Bronze	ASTM B62
Gland	Ductile Iron	A536 65-45-12
Wrench Nut	Ductile Iron	A536 65-45-12
Post Plate	Ductile Iron	A536 65-45-12

Dimensions(mm/inch):

SIZE	mm	350	400	450	500	600
	inch	14	16	18	20	24
L	mm	381	406	432	457	508
	inch	15.00	15.98	17.01	17.99	20.00
H	mm	862	938	1057	1142	1295
	inch	33.94	36.93	41.61	44.96	50.98
D	mm	305	305	305	305	305
	inch	12.01	12.01	12.01	12.01	12.01

Gate Valve

Resilient Seated NRS Type-Flange-Groove Ends

AFF-NGA-32FG-300
AFF-NGA-32FG-250
AFF-NGA-32FG-200

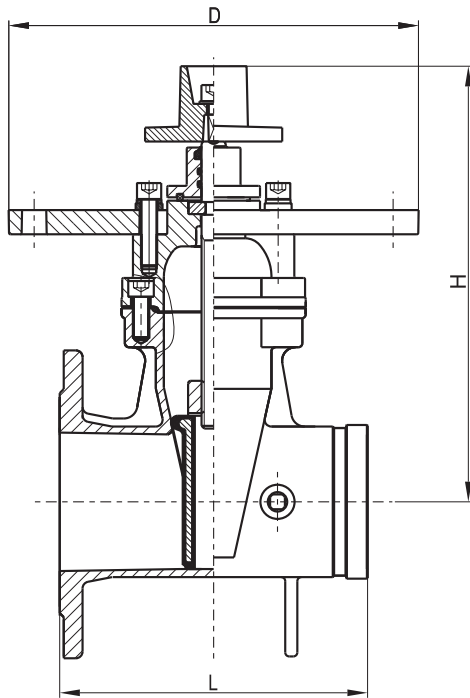

Valve Standard

Conforms to AWWA C515 / BS5163

Working pressure

200PSI / 250PSI / 300PSI

Connection Ends

ANSI B16.1 CLASS125/150
EN1092-2 PN16
AWWA C 606

Materials List

Part Name	Material	Specification
Body	Ductile Iron	A536 65-45-12
Wedge Disc	Ductile Iron EPDM Coated	
Disc Nut	Bronze	ASTM B62
Stem	Stainless Steel	AISI 304/302
Gasket	EPDM	Commercial
Bonnet	Ductile Iron	A536 65-45-12
Thrust Collar	Bronze	ASTM B62
Gland	Ductile Iron	A536 65-45-12
Wrench Nut	Ductile Iron	A536 65-45-12
Post Plate	Ductile Iron	A536 65-45-12

Dimensions(mm/inch):

SIZE	mm	50	65	80	100	125	150	200	250	300
	inch	2	2 1/2	3	4	5	6	8	10	12
L	mm	178	191	203	229	254	267	292	330	356
	inch	7.00	7.50	8.00	9.00	10.00	10.50	11.50	13.00	14.00
H	mm	279	279	305	324	394	428	537	640	723
	inch	10.98	10.98	12.01	12.76	15.51	16.85	21.14	25.20	28.46
D	mm	305	305	305	305	305	305	305	305	305
	inch	12.01	12.01	12.01	12.01	12.01	12.01	12.01	12.01	12.01



Gate Valve

Resilient Seated NRS Type-Groove-Groove Ends

AFF-NGA-32GG-300
AFF-NGA-32GG-250
AFF-NGA-32GG-200

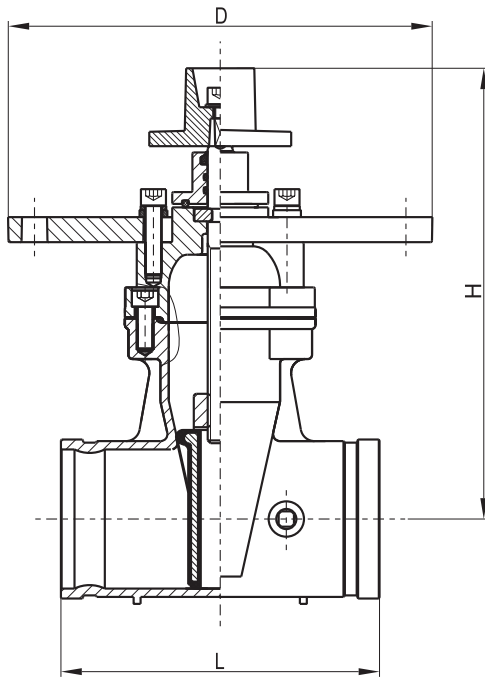
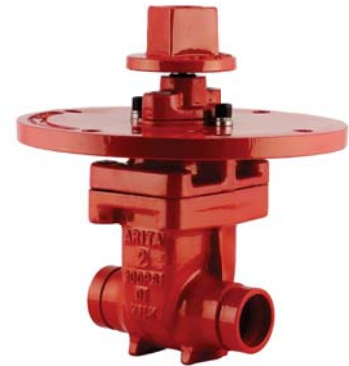

Valve Standard

Conforms to AWWA C515 / BS5163

Working pressure

200PSI / 250PSI / 300PSI

Connection Ends

AWWA C 606

Materials List

Part Name	Material	Specification
Body	Ductile Iron	A536 65-45-12
Wedge Disc	Ductile Iron EPDM Coated	
Disc Nut	Bronze	ASTM B62
Stem	Stainless Steel	AISI 304/302
Gasket	EPDM	Commercial
Bonnet	Ductile Iron	A536 65-45-12
Thrust Collar	Bronze	ASTM B62
Gland	Ductile Iron	A536 65-45-12
Wrench Nut	Ductile Iron	A536 65-45-12
Post Plate	Ductile Iron	A536 65-45-12

Dimensions(mm/inch):

SIZE	mm	50	65	80	100	125	150	200	250	300
	inch	2	2 1/2	3	4	5	6	8	10	12
L	mm	178	191	203	229	254	267	292	330	356
	inch	7.00	7.50	8.00	9.00	10.00	10.50	11.50	13.00	14.00
H	mm	279	279	305	324	394	428	537	640	723
	inch	10.98	10.98	12.01	12.76	15.51	16.85	21.14	25.20	28.46
D	mm	305	305	305	305	305	305	305	305	305
	inch	12.01	12.01	12.01	12.01	12.01	12.01	12.01	12.01	12.01

Gate Valve

Resilient Seated NRS Type-MJ-MJ Ends

AFF-NGA-32MJ-300
AFF-NGA-32MJ-250
AFF-NGA-32MJ-200

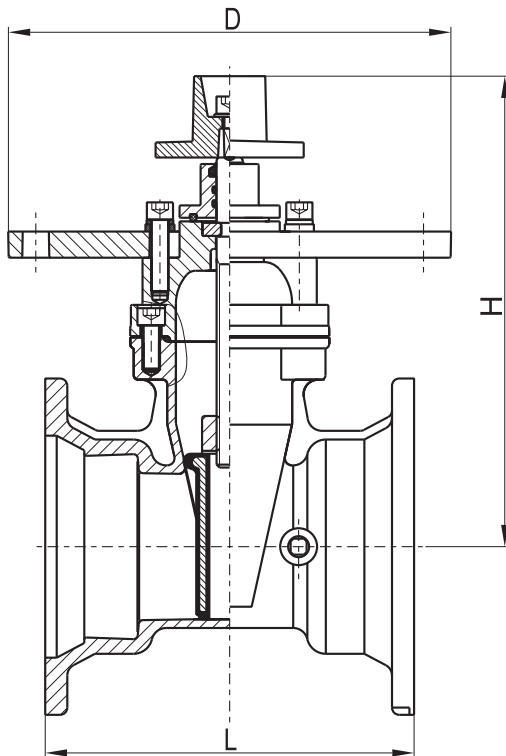

Valve Standard

Conforms to AWWA C515 / BS5163

Working pressure

200PSI / 250PSI / 300PSI

Connection Ends

AWWA C 153 / A21.11

Materials List

Part Name	Material	Specification
Body	Ductile Iron	A536 65-45-12
Wedge Disc	Ductile Iron EPDM Coated	
Disc Nut	Bronze	ASTM B62
Stem	Stainless Steel	AISI 304/302
Gasket	EPDM	Commercial
Bonnet	Ductile Iron	A536 65-45-12
Thrust Collar	Bronze	ASTM B62
Gland	Ductile Iron	A536 65-45-12
Wrench Nut	Ductile Iron	A536 65-45-12
Post Plate	Ductile Iron	A536 65-45-12

Dimensions(mm/inch):

SIZE	mm	80	100	150	200	250	300
	inch	3	4	6	8	10	12
L	mm	241	254	292	318	375	378
	inch	9.49	10.00	11.50	12.52	14.76	14.88
H	mm	305	324	428	537	640	723
	inch	12.01	12.76	16.85	21.14	25.20	28.46
D	mm	305	305	305	305	305	305
	inch	12.01	12.01	12.01	12.01	12.01	12.01



Gate Valve

Resilient Seated NRS Type-Flanged-MJ Ends

AFF-NGA-32FM-300
AFF-NGA-32FM-250
AFF-NGA-32FM-200

Valve Standard

Conforms to AWWA C515 / BS5163

Working pressure

200PSI / 250PSI / 300PSI

Connection Ends

AWWA C 153 / A21.11
ANSI B16.1 CLASS125/150
EN1092-2 PN16

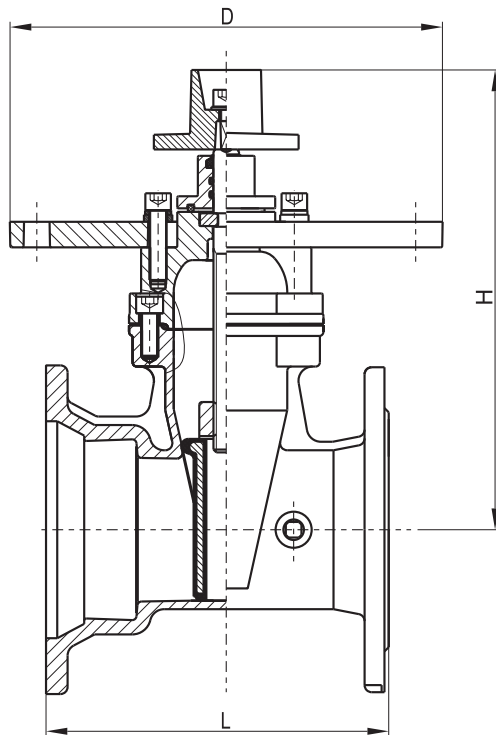

Materials List

Part Name	Material	Specification
Body	Ductile Iron	A536 65-45-12
Wedge Disc	Ductile Iron EPDM Coated	
Disc Nut	Bronze	ASTM B62
Stem	Stainless Steel	AISI 304/302
Gasket	EPDM	Commercial
Bonnet	Ductile Iron	A536 65-45-12
Thrust Collar	Bronze	ASTM B62
Gland	Ductile Iron	A536 65-45-12
Wrench Nut	Ductile Iron	A536 65-45-12
Post Plate	Ductile Iron	A536 65-45-12

Dimensions(mm/inch):

SIZE	mm	80	100	150	200	250	300
	inch	3	4	6	8	10	12
L	mm	222.0	241.5	279.5	305.0	352.5	367.0
	inch	8.74	9.51	11.00	12.01	13.88	14.45
H	mm	305	324	428	537	640	723
	inch	12.01	12.76	16.85	21.14	25.20	28.46
D	mm	305	305	305	305	305	305
	inch	12.01	12.01	12.01	12.01	12.01	12.01

Gate Valve

Resilient Seated OS&Y Type-Flanged Ends



AFF-RGA-33FF-300
AFF-RGA-33FF-250
AFF-RGA-33FF-200

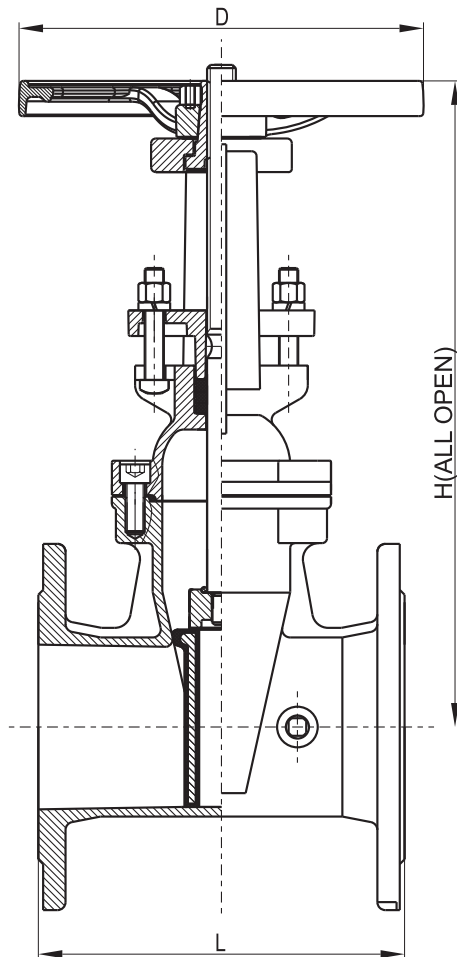

Valve Standard

Conforms to AWWA
C515 / BS5163

Working pressure

200PSI / 250PSI / 300PSI

Connection Ends

ANSI B16.1 Class125/150
EN1092-2 PN16

Materials List

Part Name	Material	Specification
Body	Ductile Iron	A536 65-45-12
Wedge	Ductile Iron EPDM Coated	
Wedge Nut	Stainless Steel	AISI304
Stem	Stainless Steel	AISI304/302
Bonnet	Ductile Iron	A536 65-45-12
Gasket	EPDM	Commercial
Packing	Graphite	Non-asbestos
Stem Nut	Bronze	ASTM B62
Handwheel	Ductile Iron	A536 65-45-12

Dimensions(mm/inch):

SIZE	mm	50	65	80	100	125	150	200	250	300
	inch	2	2 1/2	3	4	5	6	8	10	12
L	mm	178.0	191.0	203.0	229.0	254.0	267.0	292.0	330.0	356.0
	inch	7.00	7.50	8.00	9.00	10.00	10.50	11.50	13.00	14.00
H	mm	411	411	462	514	629	709	922	1116	1300
	inch	16.18	16.18	18.19	20.24	24.76	27.91	36.30	43.94	51.18
D	mm	183	183	253	253	306	306	355	445	445
	inch	7.20	7.20	9.96	9.96	12.05	12.05	13.98	17.52	17.52



Gate Valve

Resilient Seated OS&Y Type-Flanged Ends

AFF-RGA-33FF-250(DN350-DN450)
AFF-RGA-33FF-200(DN500-DN600)

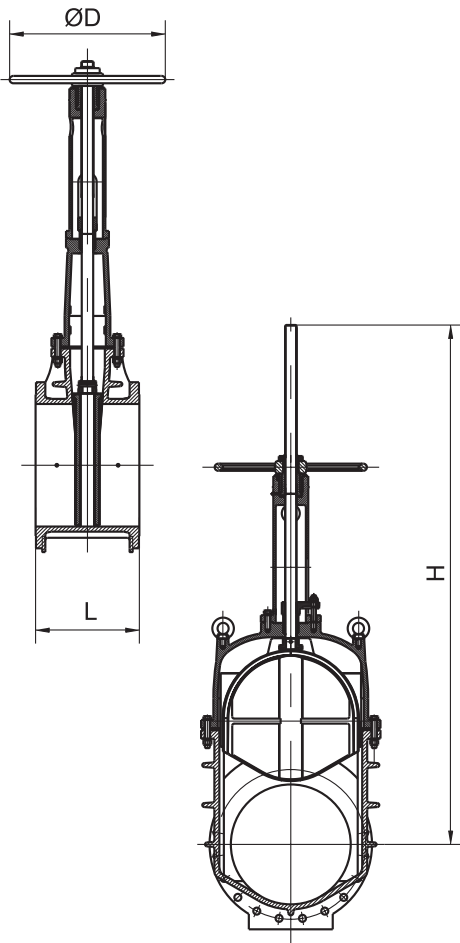

Valve Standard

Conforms to AWWA
C515 / BS5163

Working pressure

200PSI / 250PSI

Connection Ends

ANSI B16.1 Class125/150
EN1092-2 PN16

Materials List

Part Name	Material	Specification
Body	Ductile Iron	A536 65-45-12
Wedge	Ductile Iron EPDM Coated	
Wedge Nut	Stainless Steel	AISI304
Stem	Stainless Steel	AISI304/302
Bonnet	Ductile Iron	A536 65-45-12
Gasket	EPDM	Commercial
Packing	Graphite	Non-asbestos
Stem Nut	Bronze	ASTM B62
Handwheel	Ductile Iron	A536 65-45-12

Dimensions(mm/inch):

SIZE	mm	350	400	450	500	600
	inch	14	16	18	20	24
L	mm	381	406	432	457	508
	inch	15.00	15.98	17.01	17.99	20.00
H	mm	1577	1800	2048	2297	2600
	inch	62.09	70.87	80.63	90.43	102.36
D	mm	508	558	610	610	762
	inch	20.00	21.97	24.02	24.02	30.00

Gate Valve

Resilient Seated OS&Y Type-Flange-Groove Ends



AFF-RGA-33FG-300
AFF-RGA-33FG-250
AFF-RGA-33FG-200

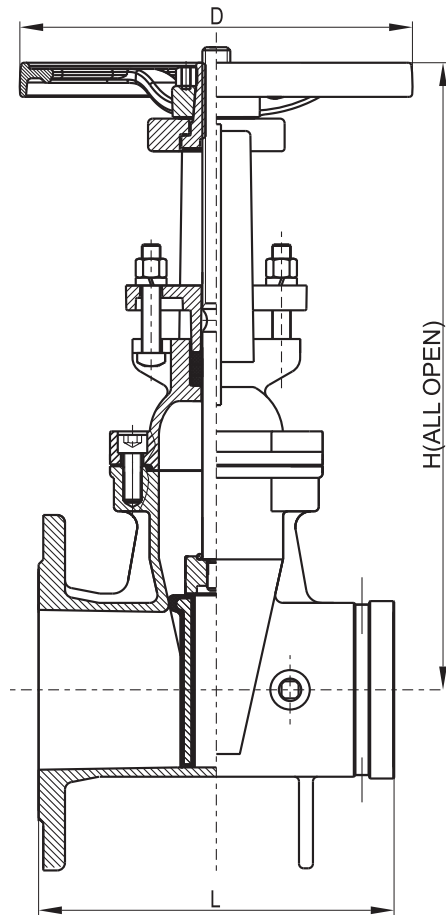

Valve Standard

Conforms to AWWA C515 / BS5163

Working pressure

200PSI / 250PSI / 300PSI

Connection Ends

ANSI B16.1 Class125/150
EN1092-2 PN16
AWWA C 606



Materials List

Part Name	Material	Specification
Body	Ductile Iron	A536 65-45-12
Wedge	Ductile Iron EPDM Coated	
Wedge Nut	Stainless Steel	AISI304
Stem	Stainless Steel	AISI304/302
Bonnet	Ductile Iron	A536 65-45-12
Gasket	EPDM	Commercial
Packing	Graphite	Non-asbestos
Stem Nut	Bronze	ASTM B62
Handwheel	Ductile Iron	A536 65-45-12

Dimensions(mm/inch):

SIZE	mm	50	65	80	100	125	150	200	250	300
	inch	2	2 1/2	3	4	5	6	8	10	12
L	mm	178.0	191.0	203.0	229.0	254.0	267.0	292.0	330.0	356.0
	inch	7.00	7.50	8.00	9.00	10.00	10.50	11.50	13.00	14.00
H	mm	411	411	462	514	629	709	922	1116	1300
	inch	16.18	16.18	18.19	20.24	24.76	27.91	36.30	43.94	51.18
D	mm	183	183	253	253	306	306	355	445	445
	inch	7.20	7.20	9.96	9.96	12.05	12.05	13.98	17.52	17.52



Gate Valve

Resilient Seated OS&Y Type-Groove-Groove Ends

AFF-RGA-33GG-300
AFF-RGA-33GG-250
AFF-RGA-33GG-200

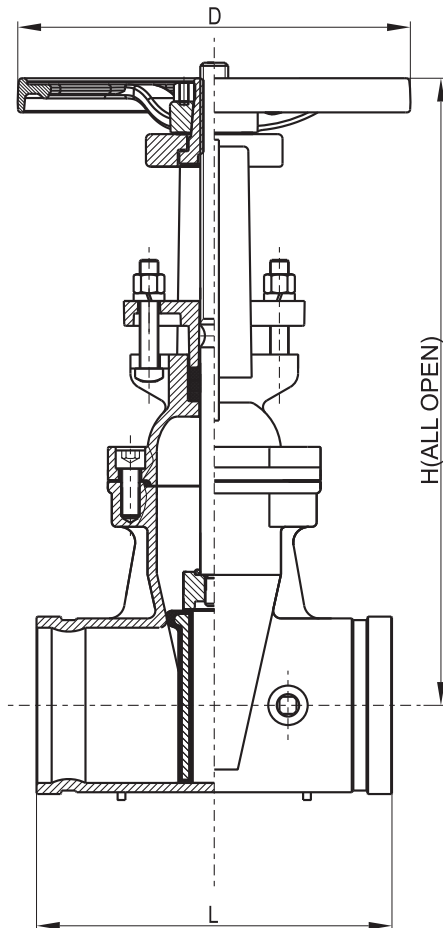

Valve Standard

Conforms to AWWA C515 / BS5163

Working pressure

200PSI / 250PSI / 300PSI

Connection Ends

AWWA C 606

Materials List

Part Name	Material	Specification
Body	Ductile Iron	A536 65-45-12
Wedge	Ductile Iron EPDM Coated	
Wedge Nut	Stainless Steel	AISI304
Stem	Stainless Steel	AISI304/302
Bonnet	Ductile Iron	A536 65-45-12
Gasket	EPDM	Commercial
Packing	Graphite	Non-asbestos
Stem Nut	Bronze	ASTM B62
Handwheel	Ductile Iron	A536 65-45-12

Dimensions(mm/inch):

SIZE	mm inch	50 2	65 2 1/2	80 3	100 4	125 5	150 6	200 8	250 10	300 12
L	mm	178.0	191.0	203.0	229.0	254.0	267.0	292.0	330.0	356.0
	inch	7.00	7.50	8.00	9.00	10.00	10.50	11.50	13.00	14.00
H	mm	411	411	462	514	629	709	922	1116	1300
	inch	16.18	16.18	18.19	20.24	24.76	27.91	36.30	43.94	51.18
D	mm	183	183	253	253	306	306	355	445	445
	inch	7.20	7.20	9.96	9.96	12.05	12.05	13.98	17.52	17.52

Gate Valve

Resilient Seated OS&Y Type-MJ-MJ Ends



AFF-RGA-33MJ-300
AFF-RGA-33MJ-250
AFF-RGA-33MJ-200

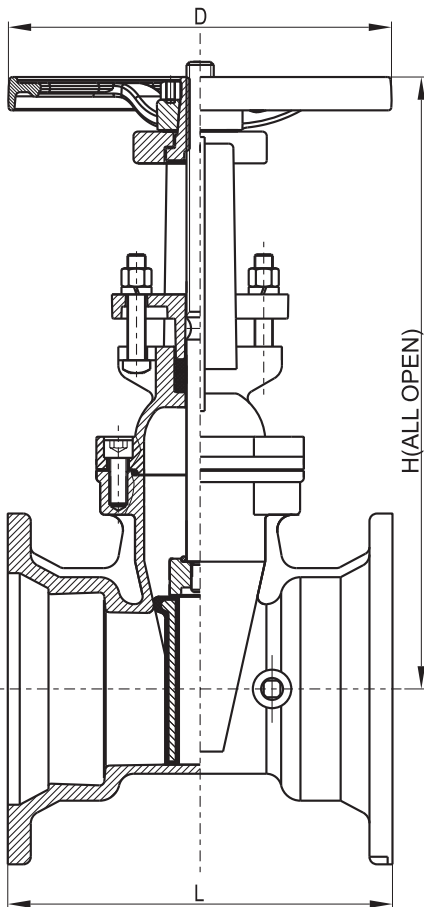

Valve Standard

Conforms to AWWA
C515 / BS5163

Working pressure
200PSI / 250PSI / 300PSI

Connection Ends
AWWA C153/A21.11



Materials List

Part Name	Material	Specification
Body	Ductile Iron	A536 65-45-12
Wedge	Ductile Iron EPDM Coated	
Wedge Nut	Stainless Steel	AISI304
Stem	Stainless Steel	AISI304/302
Bonnet	Ductile Iron	A536 65-45-12
Gasket	EPDM	Commercial
Packing	Graphite	Non-asbestos
Stem Nut	Bronze	ASTM B62
Handwheel	Ductile Iron	A536 65-45-12

Dimensions(mm/inch):

SIZE	mm	80	100	150	200	250	300
	inch	3	4	6	8	10	12
L	mm	241	254	292	318	375	378
	inch	9.49	10.00	11.50	12.52	14.76	14.88
H	mm	462	514	709	922	1116	1300
	inch	18.19	20.24	27.91	36.30	43.94	51.18
D	mm	253	253	306	355	445	445
	inch	9.96	9.96	12.05	13.98	17.52	17.52



Gate Valve

Resilient Seated OS&Y Type-Flanged-MJ Ends

AFF-RGA-33FM-300
AFF-RGA-33FM-250
AFF-RGA-33FM-200

Valve Standard

Conforms to AWWA
C515 / BS5163

Working pressure

200PSI / 250PSI / 300PSI

Connection Ends

AWWA C153/A21.11
ANSI B16.1 CLASS125/150
EN1092-2 PN16

Materials List

Part Name	Material	Specification
Body	Ductile Iron	A536 65-45-12
Wedge	Ductile Iron EPDM Coated	
Wedge Nut	Stainless Steel	AISI304
Stem	Stainless Steel	AISI304/302
Bonnet	Ductile Iron	A536 65-45-12
Gasket	EPDM	Commercial
Packing	Graphite	Non-asbestos
Stem Nut	Bronze	ASTM B62
Handwheel	Ductile Iron	A536 65-45-12

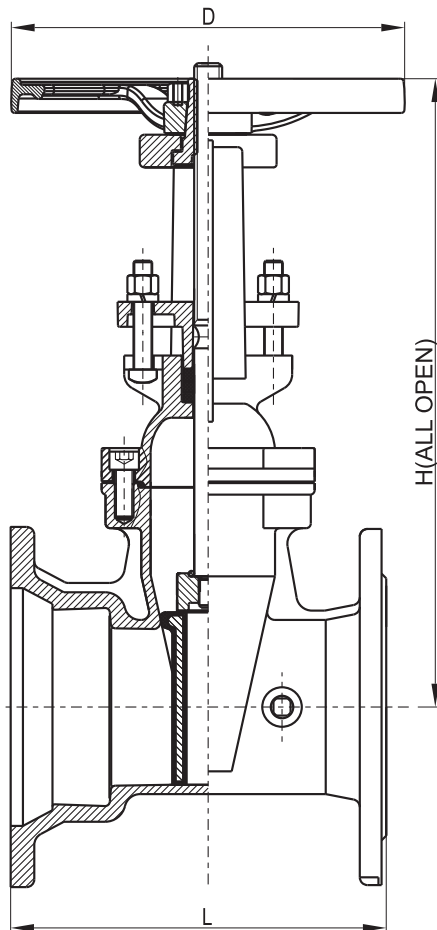

Dimensions(mm/inch):

SIZE	mm	80	100	150	200	250	300
	inch	3	4	6	8	10	12
L	mm	222	241.5	279.5	305	352.5	367
	inch	8.74	9.51	11.00	12.01	13.88	14.45
H	mm	462	514	709	922	1116	1300
	inch	18.19	20.24	27.91	36.30	43.94	51.18
D	mm	253	253	306	355	445	445
	inch	9.96	9.96	12.05	13.98	17.52	17.52

Gate Valve

Pressure-Temperature Chart

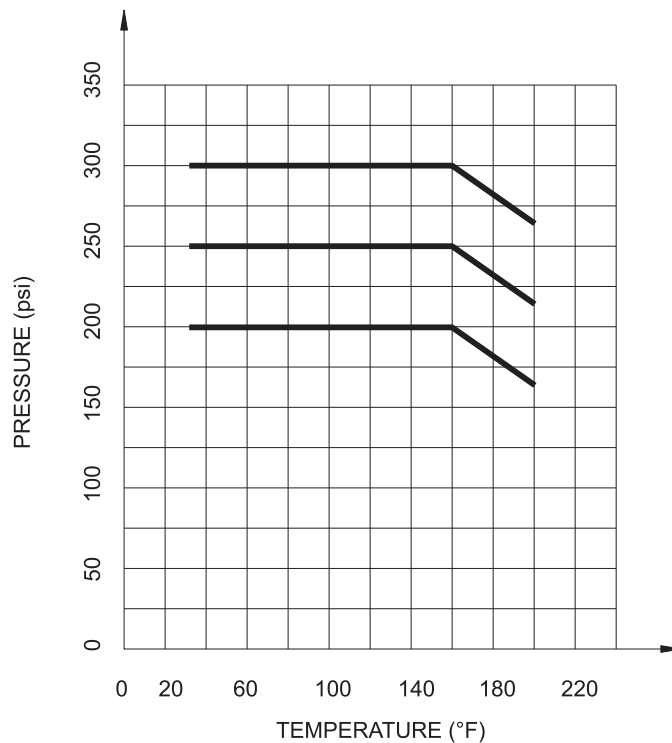
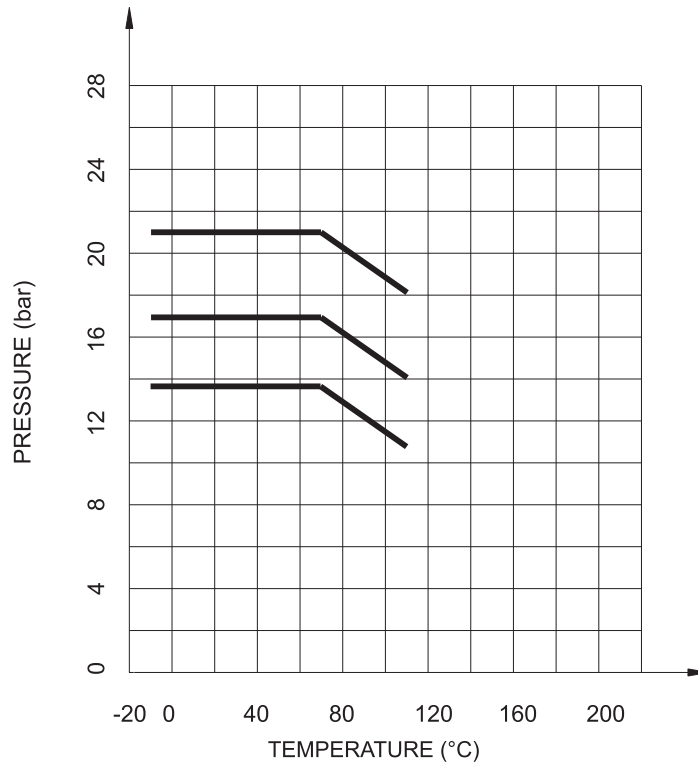



Butterfly Valve

Resilient Seated Grooved Ends

AFF-BF-25G-200
AFF-BF-25G-250
AFF-BF-25G-300

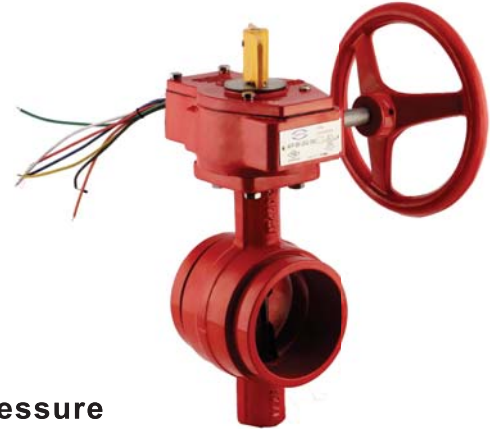
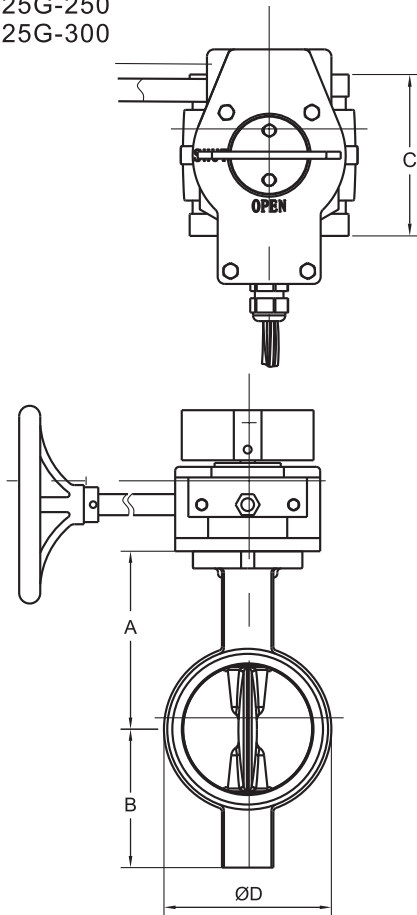

Working pressure
200PSI / 250PSI / 300PSI

Connection Ends
AWWA C606/GB/T 8260

Materials List

Component	Material	Specification
Body	Ductile Iron	A536 65-45-12
Disc	Ductile Iron EPDM Coated	
Upper&Lower Stems	Stainless Steel	AISI 410
Worn Gear Shaft	Stainless Steel	AISI 410
Housing	Cast Iron	A126 B
Hand Wheel	Ductile Iron	A536 65- 45-12B
O-Rings(All)	EPDM Grade"E"	

Dimensions(mm/inch)

SIZE	mm	50	65	80	100	125	150	200	250	300
	inch	2	2½	3	4	5	6	8	10	12
A	mm	95	98	105	135	148	165	204	245	277.5
	inch	3.74	3.87	4.13	5.31	5.83	6.50	8.03	9.65	10.93
B	mm	78	78	85	105	128	140	170	205	258
	inch	3.07	3.07	3.35	4.13	5.04	5.51	6.69	8.07	10.16
C	mm	84.5	98	98	116	149	147.6	134	160	165
	inch	3.33	3.86	3.86	4.57	5.87	5.81	5.28	6.30	6.50
ØD	mm	72	88	98	127	156	185	235	292	323.85
	inch	2.83	3.46	3.86	5.00	6.14	7.28	9.25	11.49	12.75

Factory installed UL listed Double Tamper Switches for indoor and outdoor use.



Butterfly Valve

Resilient Seated Wafer Ends

AFF-BF-25W-300
AFF-BF-25W-250

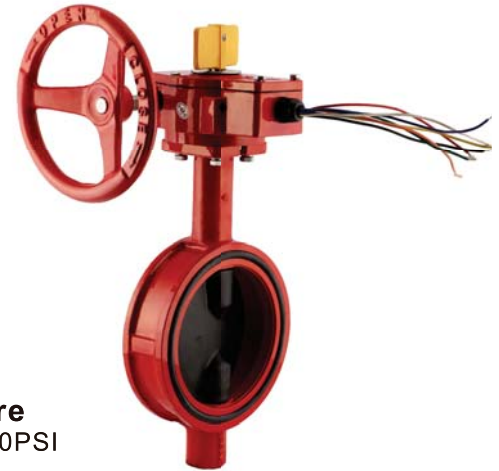
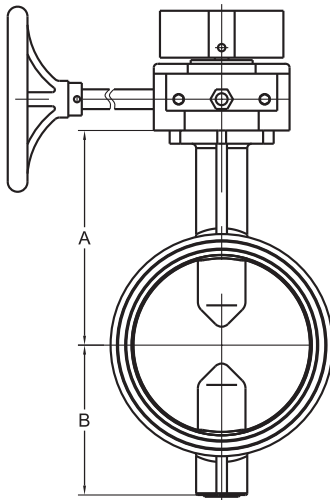
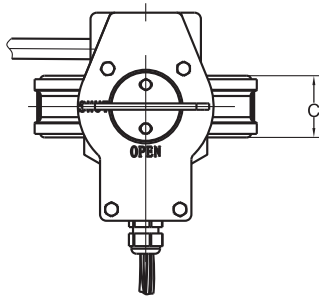

Working pressure
200PSI / 250PSI / 300PSI

Flanged Ends
ANSI B16.1 Class125/150
EN1092-2 PN10/PN16/PN25

Materials List

Component	Material	Specification
Body	Ductile Iron	A536 65-45-12
Disc	Ductile Iron EPDM Coated	
Upper&Lower Stems	Stainless Steel	AISI 410
Worn Gear Shaft	Stainless Steel	AISI 410
Housing	Cast Iron	A126 B
Hand Wheel	Ductile Iron	A536 65-45-12B
O-Rings(All)	EPDM Grade"E"	

Dimensions(mm/inch)

SIZE	mm	50	65	80	100	125	150	200	250	300
	inch	2	2½	3	4	5	6	8	10	12
A	mm	141	153	158	176	191	203	244	273	311
	inch	5.55	6.02	6.22	6.93	7.52	7.99	9.61	10.75	12.24
B	mm	78	78	85	105	128	140	170	205	258
	inch	3.07	3.07	3.35	4.13	5.04	5.51	6.69	8.07	10.16
C	mm	43	46	46	52	56	56	62	68	78
	inch	1.69	1.81	1.81	2.05	2.20	2.20	2.44	2.68	3.07

Factory installed UL listed Double Tamper Switches for indoor and outdoor use.

Butterfly Valve

Resilient Seated Lug Ends



AFF-BF-25L-200
AFF-BF-25L-250
AFF-BF-25L-300

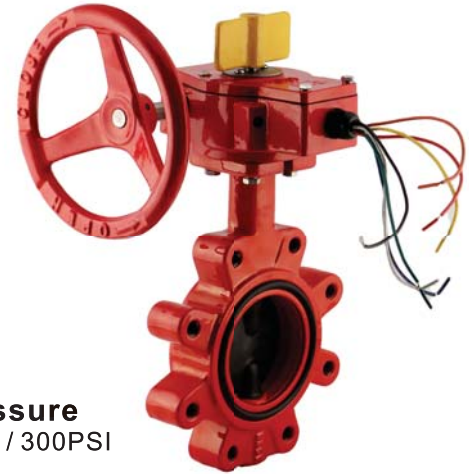
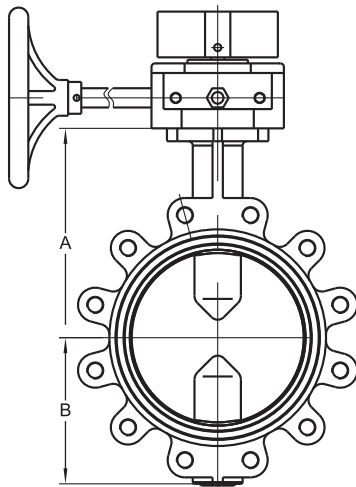
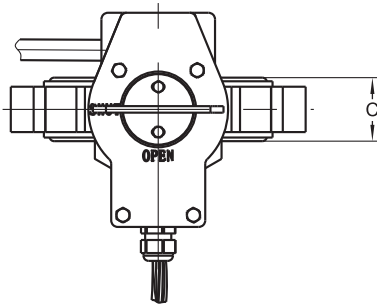

Working pressure
200PSI / 250PSI / 300PSI

Flanged Ends
ANSI B16.1 Class125/150,
EN1092-2 PN16

Materials List

Component	Material	Specification
Body	Ductile Iron	A536 65-45-12
Disc	Ductile Iron EPDM Coated	
Upper&Lower Stems	Stainless Steel	AISI 410
Worn Gear Shaft	Stainless Steel	AISI 410
Housing	Cast Iron	A126 B
Hand Wheel	Ductile Iron	A536 65- 45-12B
O-Rings(All)	EPDM Grade"E"	

Dimensions(mm/inch)

SIZE	mm	50	65	80	100	125	150	200	250	300
	inch	2	2½	3	4	5	6	8	10	12
A	mm	141	153	158	176	191	203	244	273	311
	inch	5.55	6.02	6.22	6.93	7.52	7.99	9.61	10.75	12.24
B	mm	78	78	85	105	128	140	170	205	258
	inch	3.07	3.07	3.35	4.13	5.04	5.51	6.69	8.07	10.16
C	mm	43	46	46	52	56	56	62	68	78
	inch	1.69	1.81	1.81	2.05	2.20	2.20	2.44	2.68	3.07

Factory installed UL listed Double Tamper Switches for indoor and outdoor use.

Swing Check Valve

Resilient Seated Flanged Ends



AFF-SW-55FF-300
AFF-SW-55FF-250
AFF-SW-55FF-200

Valve Standard

Conforms to AWWA C508, Clear Waterway

Working pressure

200PSI / 250PSI / 300PSI

Flanged Ends

ANSI B16.1 Class125/150/250,
EN1092-2 PN10/PN16/PN25
BS10 Table D/Table E

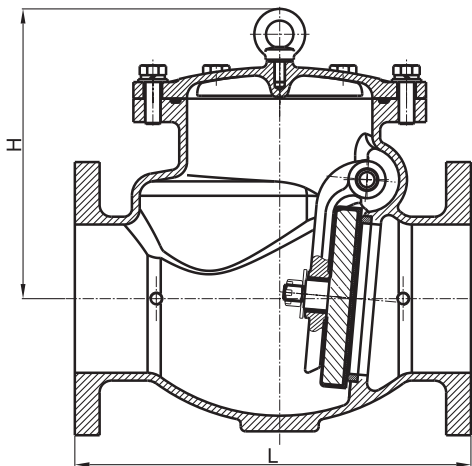
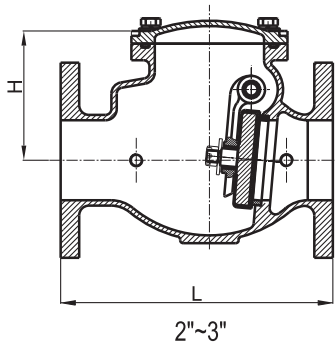

Materials List

Part Name	Material	Specification
Body	Ductile Iron	A536 65-45-12
Cover	Ductile Iron	A536 65-45-12
Clapper	Ductile Iron	A536 65-45-12+EPDM
Clapper Arm	Ductile Iron	A536 65-45-12
Hinge Pin	Stainless Steel	AISI 304
Seat	Bronze	ASTM B62
	Stainless Steel	AISI 304

Dimensions(mm/inch)

SIZE	mm	50	65	80	100	125	150	200	250	300
	inch	2	2½	3	4	5	6	8	10	12
L	mm	203	254	279	330	356	406	495	559	660
	inch	8	10	11	13	14	16	19.5	22	26
H	mm	117	128	132.5	222.5	290	297	365	417.5	453
	inch	4.61	5.04	5.22	8.76	11.42	11.69	14.37	16.44	17.83



Swing Check Valve

Resilient Seated Grooved Ends

AFF-SW-56GG-350



Working pressure
350PSI

Connection Ends
AWWA C 606

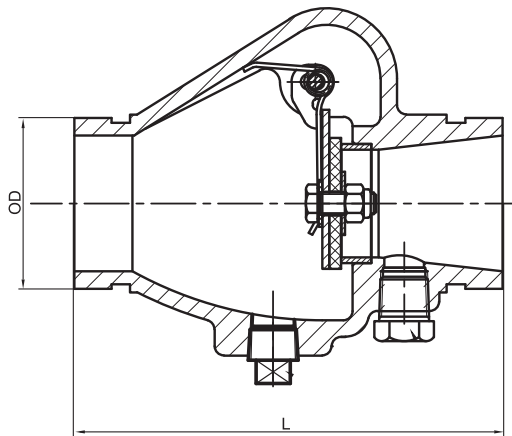

Materials List

Part Name	Material	ASTM Specification
Body	Ductile Iron	A536 65-45-12
Seat	Bronze	ASTM B148
Clapper	Stainless Steel	ASTM A276
Facing Seal	EPDM Rubber	
Clamping Ring	Stainless Steel	ASTM A276
Gasket	EPDM Rubber	
Spring	Stainless Steel	ASTM A276
Hinge Pin	Stainless Steel	ASTM A276
Bolt	Stainless Steel	ASTM A276
Lock Nut	Stainless Steel	ASTM A276
Plug 1/4" NPT	Carbon Steel	ASTM A29
Plug 1/2" NPT	Carbon Steel	ASTM A29
Plug 2" NPT	Carbon Steel	ASTM A29

Dimensions(mm/inch)

SIZE	mm	50	65	80	100	125	150	200	250	300
	inch	2	2½	3	4	5	6	8	10	12
L	mm	169	181	198	214	248	270	325	457	535
	inch	6.65	7.12	7.8	8.42	9.76	10.63	12.8	18	21
OD	mm	60.3	73	88.9	114.3	141.3	168.3	219.1	273	323.9
	inch	2.37	2.87	3.5	4.5	5.56	6.62	8.62	10.75	12.75

Check Valve

Resilient Seated Wafer Ends

AFF-DP-50W-300
AFF-DP-50W-250
AFF-DP-50W-200

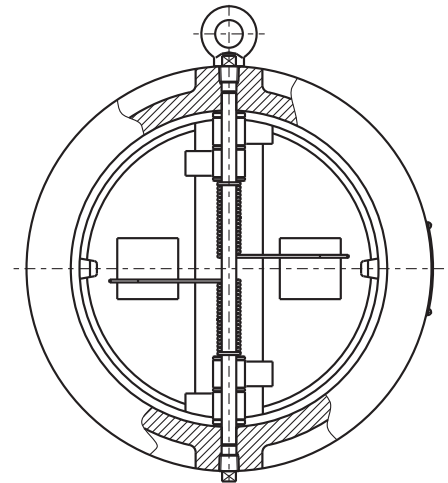
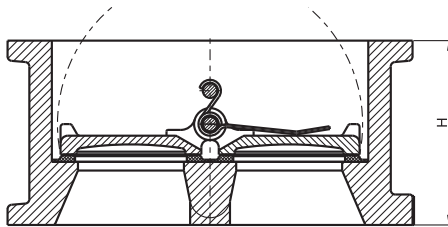

Valve Standard

Conforms to API 594

Working pressure

200PSI / 250PSI / 300PSI

Flanged Ends

ANSI B16.1 Class125/150

Materials List

Part	Material	ASTM Spec.
Body	Cast Iron	A126 Class B
	Ductile Iron	A536 65-45-12
Disc	Ductile Iron	A536 65-45-12
	Aluminum Bronze	B584 C95400
	Stainless Steel	A351 CF8
Stem	Stainless Steel	A351 CF8M
	Stainless Steel	AISI 316
Seat-Ring	EPDM / NBR	Commercial
Spring	Stainless Steel	AISI 316
	Stainless Steel	AISI 304

Dimensions(mm/inch)

SIZE	mm	50	65	80	100	125	150	200	250	300
	inch	2	2½	3	4	5	6	8	10	12
H	mm	54	60	67	67	83	95	127	140	181
	inch	2.13	2.36	2.64	2.64	3.27	3.74	5.00	5.51	7.13

Check Valve

Pressure-Temperature Chart

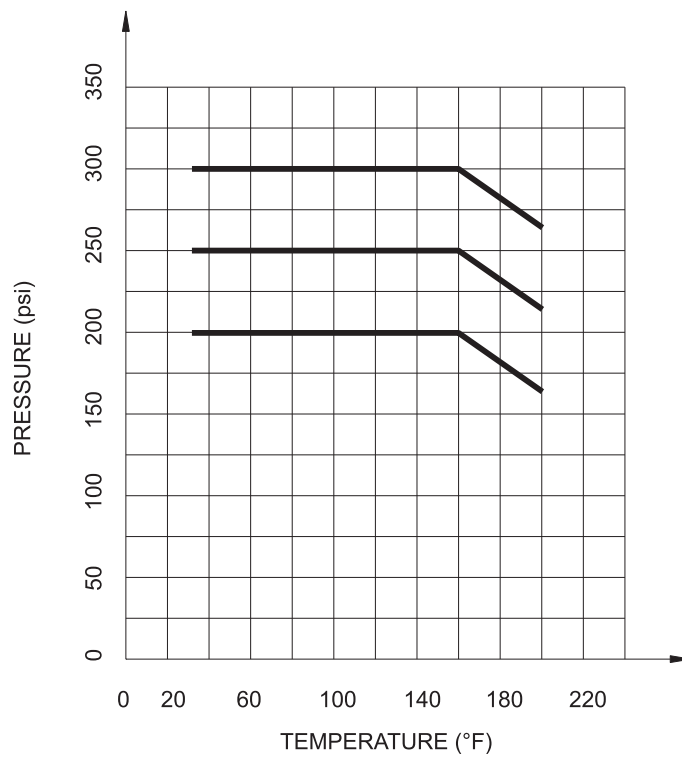
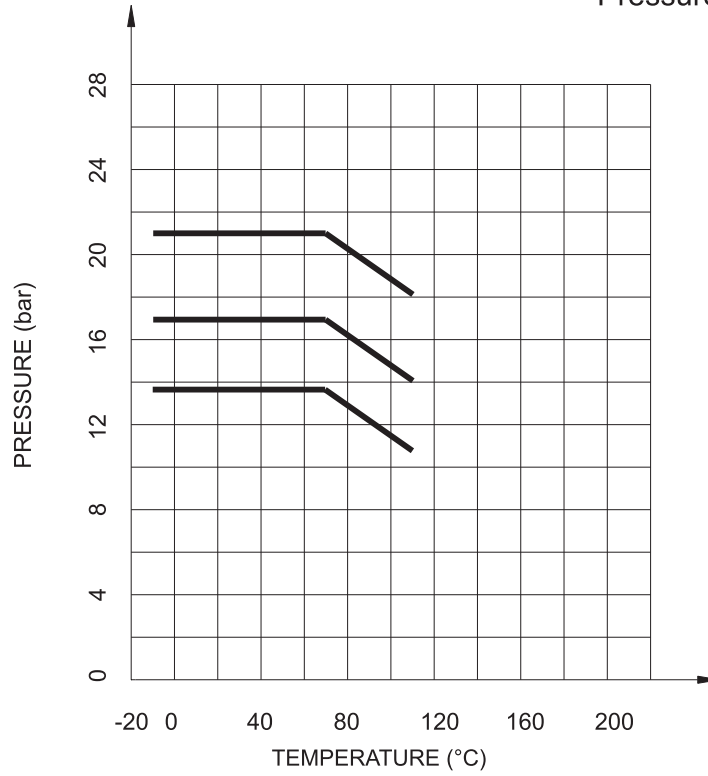

Y Strainer

Flange-Flange Ends

AFF-YS-70FF-300
AFF-YS-70FF-250
AFF-YS-70FF-200

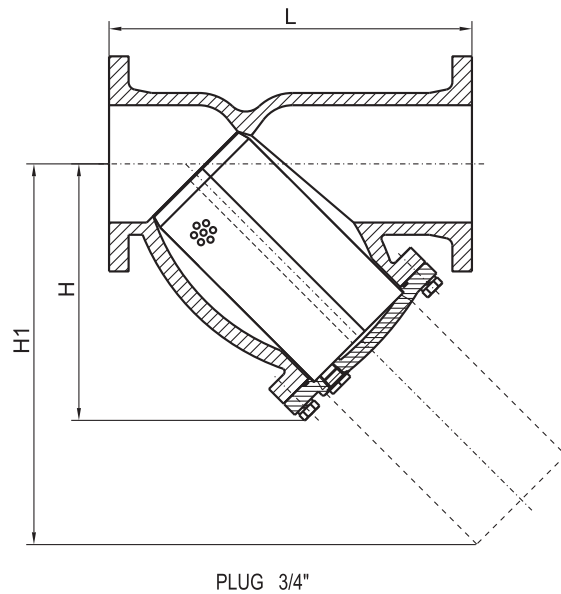

Working pressure
200PSI / 250PSI / 300PSI

Flanged Ends
ANSI B16.1 Class125/150/250,
EN1092-2 PN10/PN16/PN25
BS10 Table D/Table E

Materials List

Component	Material	Specification
Body	Ductile Iron	A536 65-45-12
Cover	Ductile Iron	A536 65-45-12
Screen	Stainless Steel	AISI 304
Gasket	EPDM	
Plug	Carbon Steel	

Dimensions(mm/inch)

SIZE	mm	50	65	80	100	125	150	200	250	300
	inch	2	2½	3	4	5	6	8	10	12
L	mm	203	254	260	308	398	472	550	654	762
	inch	7.99	10	10.24	12.13	15.67	18.58	21.65	25.75	30
H	mm	132	158	175	202	290	334	391	460	590
	inch	5.20	6.22	6.89	7.99	11.42	13.15	15.39	18.11	23.23
H1	mm	195	240	270	320	425	495	570	700	840
	inch	7.68	9.45	10.63	12.60	16.73	19.49	22.44	27.56	33.07

Y Strainer

Flange-Groove Ends

AFF-YS-70FG-300
AFF-YS-70FG-250
AFF-YS-70FG-200

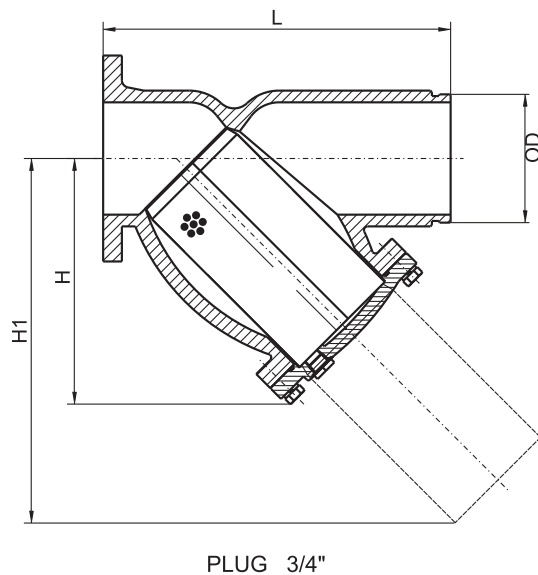

Working pressure

200PSI / 250PSI / 300PSI

Flanged Ends

ANSI B16.1 Class125/150/250,
EN1092-2 PN10/PN16/PN25
BS10 Table D/Table E
AWWA C 606

Materials List

Component	Material	Specification
Body	Ductile Iron	A536 65-45-12
Cover	Ductile Iron	A536 65-45-12
Screen	Stainless Steel	AISI 304
Gasket	EPDM	
Plug	Carbon Steel	

Dimensions(mm/inch)

SIZE	mm	50	65	80	100	125	150	200	250	300
	inch	2	2½	3	4	5	6	8	10	12
L	mm	203	254	260	308	398	472	550	654	762
	inch	8	10	10.24	12.13	15.67	18.58	21.65	25.75	30
H	mm	130	158	175	202	290	334	391	460	590
	inch	5.12	6.22	6.89	7.95	11.42	13.15	15.39	18.11	23.23
H1	mm	195	240	270	320	425	495	570	700	840
	inch	7.68	9.45	10.63	12.60	16.73	19.49	22.44	27.56	33.07
OD	mm	60.3	73.0/76.1	88.9	114.3	139.7/141.3	165.1/168.3	219.1	273	323.9
	inch	2.37	2.87/3	3.50	4.5	5.5/5.56	6.5/6.63	8.63	10.75	12.75

Y Strainer

Groove-Groove Ends

AFF-YS-70GG-300
AFF-YS-70GG-250
AFF-YS-70GG-200

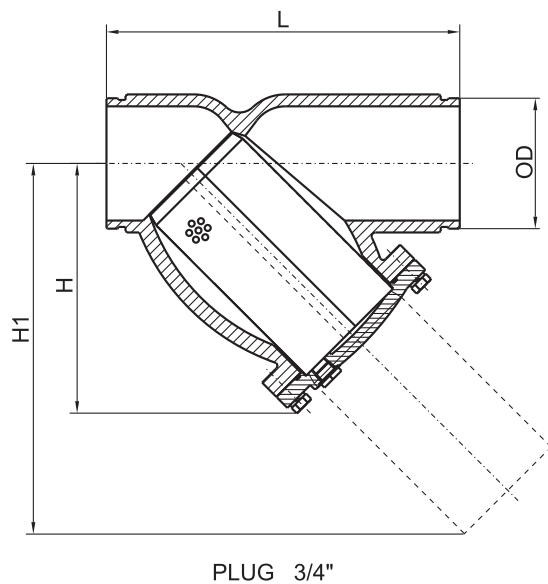

Working pressure
200PSI / 250PSI / 300PSI

Flanged Ends
AWWA C 606

Materials List

Component	Material	Specification
Body	Ductile Iron	A536 65-45-12
Cover	Ductile Iron	A536 65-45-12
Screen	Stainless Steel	AISI 304
Gasket	EPDM	
Plug	Carbon Steel	

Dimensions(mm/inch)

SIZE	mm	50	65	80	100	125	150	200	250	300
	inch	2	2½	3	4	5	6	8	10	12
L	mm	230	254	272.4	308	398	472	550	654	762
	inch	9.06	10	10.71	12.13	15.67	18.58	21.65	25.75	30
H	mm	130	158	175	202	290	334	391	460	590
	inch	5.12	6.22	6.89	8	11.42	13.15	15.39	18.11	23.23
H1	mm	195	240	270	320	425	495	570	700	840
	inch	7.68	9.45	10.63	12.60	16.73	19.49	22.44	27.56	33.07
OD	mm	60.3	73.0/76.1	88.9	114.3	139.7/141.3	165.1/168.3	219.1	273	323.9
	inch	2.37	2.87/3	3.50	4.5	5.5/5.56	6.5/6.63	8.63	10.75	12.75

Y Strainer

Pressure-Temperature Chart

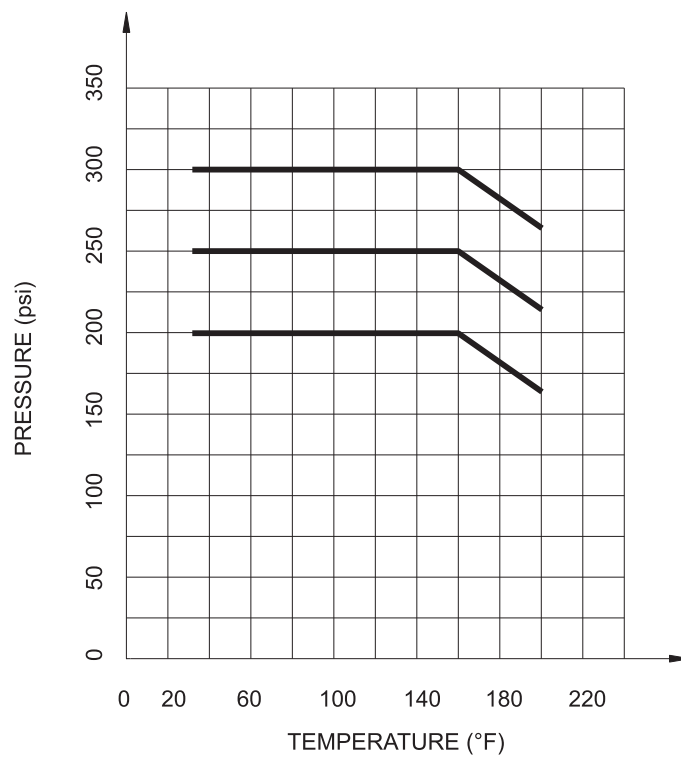
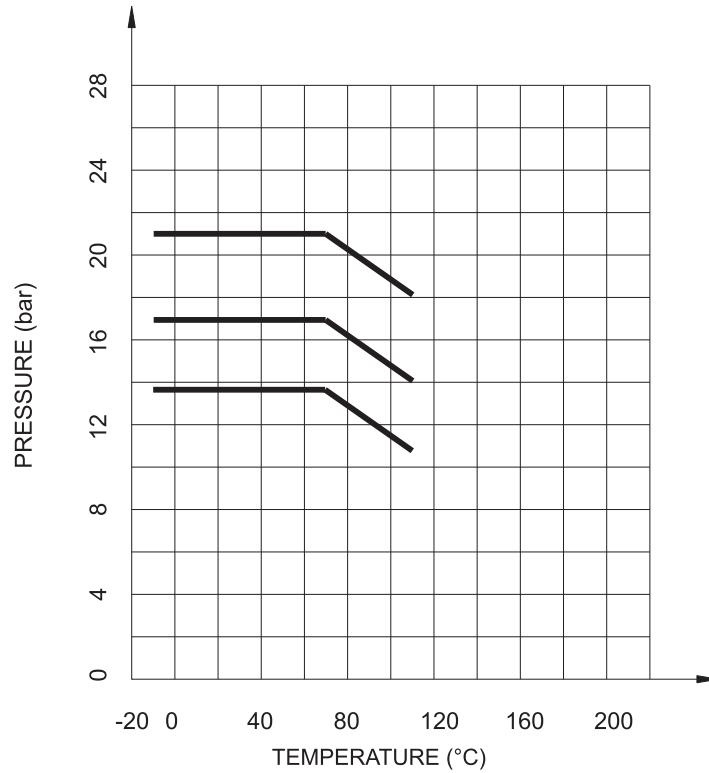

Air Release Valve

Screw End

AFF-AV-97N

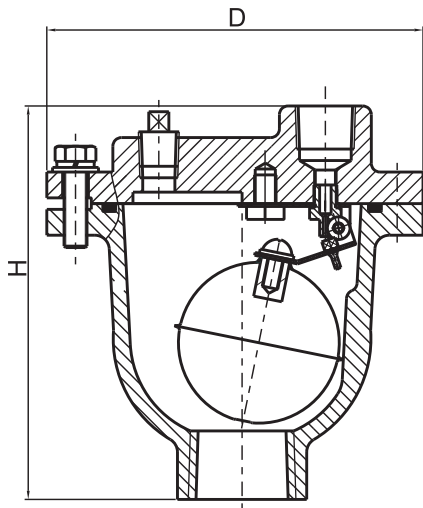

Working pressure
200PSI

Connection Ends
NPT/BSPT/BSPP

Materials List

Part	Material	ASTM Spec.
Body	Ductile Iron	A536 65-45-12
Cover	Ductile Iron	A536 65-45-12
Level	Stainless Steel	AISI 304
Seat Ring	Stainless Steel	AISI 304
Float	Stainless Steel	AISI 304
Float Arm	Stainless Steel	AISI 304
Orifice Button	Viton	Commercial

Dimensions

mm	DN		Inlet	Outlet	Orifice	D	H
	inch						
15	1/2		15	15	1.6	125	137
20	3/4		20	15	1.6	125	137
25	1		25	15	1.6	125	137

Product Code

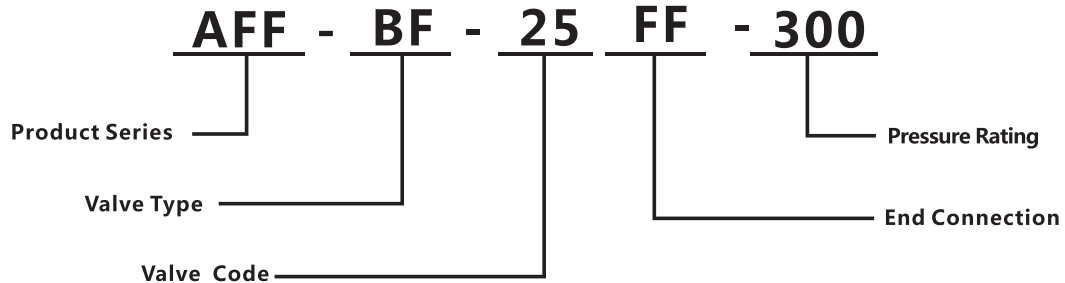

PRODUCT SERIES	VALVE TYPE	VALVE CODE	END CON	PRESSURE RATING
AFF-ARITA Fire Solutions	BF-Butterfly Valve	25, 28, 29	FF-Flange&Flange	200-200PSI
	SW-Check Valve	55, 56, 57	FG-Flange&Groove	250-250PSI
	YS-Y Strainer	70	GG-Groove&Groove	300-300PSI
	NGA-NRS Gate Valve	32	MJ-Mechanical Joint	350-350PSI
	RGA-OS&Y Gate Valve	33	FM-Flange&MJ	
	AV- Air Release Valve	97	N-NPT Tread	
	UIP-Wall Post Indicator	W38	L-Lug	
	UIP-Underground Post Indicator	G38	W-Wafer	

CAUTION

Technical data published in this catalog have been developed from our design calculation, in-house testing, field reports provided by our customers and/or published official standard or specifications. They are good only to cover typical applications as a general guideline to users of ARITA products introduced in this catalog.

For any specific application, users are kindly requested to contact ARITA for technical advice, or to carry out their own study and evaluation for providing suitability of the products to such an application. Failure to follow this request could result in property damage and/or personal injury, for which we shall not be liable.

While this catalog has been compiled with the utmost care, we assume no responsibility for errors, impropriety or inadequacy. Any information provided in this catalog is subject to from time-to-time change without notice for error rectification, product discontinuation, design modification, new product introduction or any other causeS that ARITA considers necessary. This edition cancels all previous issues.

Arita Valve (Houston) Inc.

Houston TX USA

www.unimechflow.com

info@unimechflow.com

Distributor: